

Proposal Basic Information

Proposal File No.	JNAC/BP/0086/W1/2023
Owner Name	KIRAN DEVI
Khata No	540
Plot No	255(p)
Village Name	SONARI
Use	Residential
SubUse	Bungalow/ Dwelling / Non Apartment

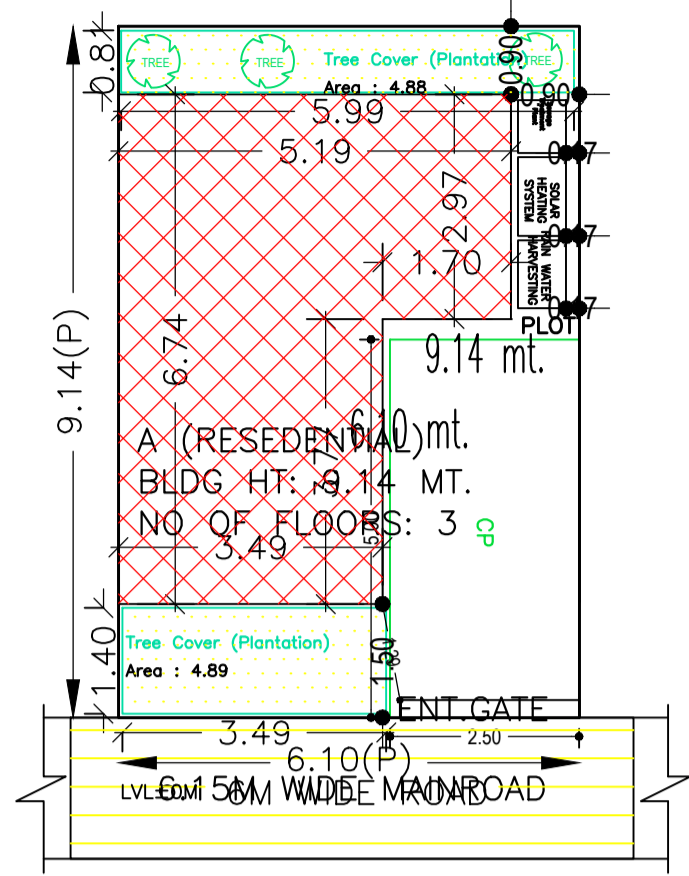

SITE PLAN

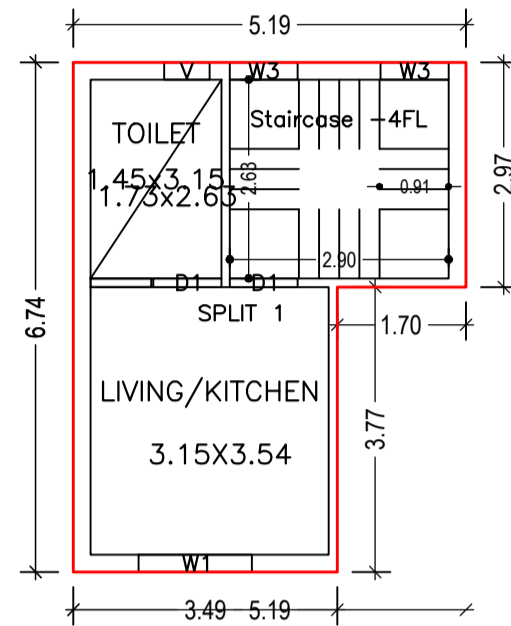

GROUND AND PARKING FLOOR PLAN (Proposed) (SCALE 1:100)

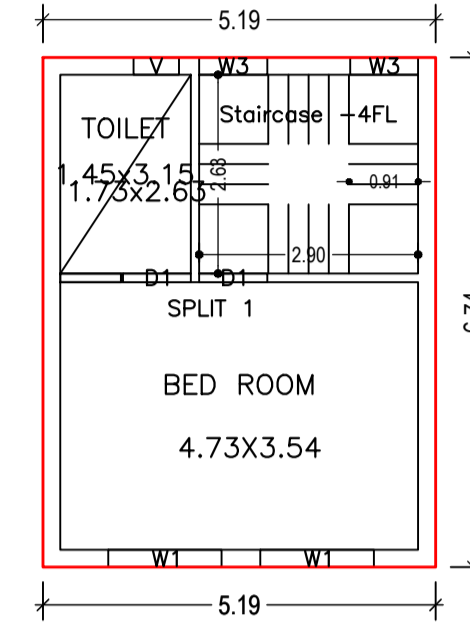

TYPICAL - 1, 2 FLOOR PLAN (Proposed) (SCALE 1:100)

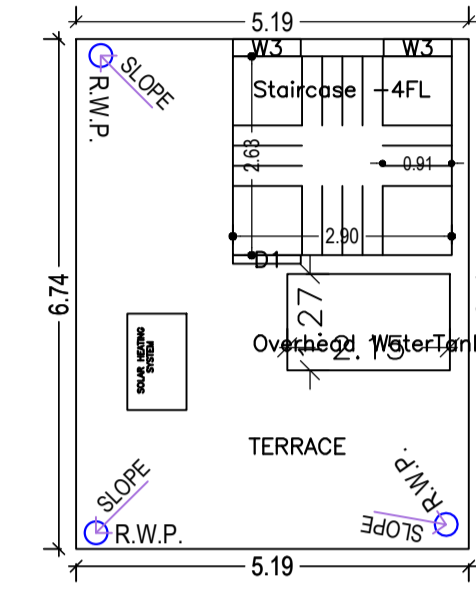

TERRACE FLOOR PLAN (SCALE 1:100)

AREA STATEMENT JAMSHEDPUR NAC	VERSION NO.: 1.0.66 VERSION DATE: 16/10/2020
PROJECT DETAIL:	
Region: JHARKHAND URBAN LOCAL BODIES	Plot Use: Residential
District: EAST SINGHBHUM	Plot SubUse: Bungalow/ Dwelling / Non Apartment
Authority: JAMSHEDPUR NAC	PlotNearby/ReligiousStructure: NA
Inward_No: JNAC/BP/0086/W1/2023	Plot/SubPlot No: 255(p)
Application Type: General Proposal	North: Plot No. - 255(p)
Project Type: Building Permission	South: Road Width -
Nature of Development: New	East: Plot No. - 255(p)
Location of Development Area: Old Area	West: Plot No. - 255(p)
AREA DETAILS:	
AREA OF PLOT (Minimum)	(A) 55.74 SQ.MT.
NET AREA OF PLOT(Gross Plot Area - Deduction from Gross Plot area)	(A-Deductions) 55.74
Deduction for Balance Plot Area(from Gross Plot Area)	
Common Plot	9.77
Total	9.77
BALANCE AREA OF PLOT(Net Plot Area - Recreational/Amenity space)	(A-Deductions) 45.97
PLOT AREA FOR COVERAGE(Net Plot Area)	(A-Deductions) 55.74
Plot Area for FAR (Net Plot Area + RoadWidening Area)	(A-Deductions) 55.74
COVERAGE CHECK	
Permissible Coverage area (70.00 %)	39.02
Proposed Coverage Area (51.29 %)	28.59
Total Prop. Coverage Area (51.29 %)	28.59
Balance coverage area (18.71 %)	10.43
FAR CHECK	
Perm. FAR Area (2.500)	139.35
Total Perm. FAR area	139.35
Residential FAR	98.60
Proposed FAR Area	98.60
Total Proposed FAR Area	98.60
Consumed FAR (Factor)	1.77
Balance FAR Area	40.75
BUILT UP AREA CHECK	
Total Proposed BuiltUp Area	98.61
ARCHITECT (Regd)	Abhishek Tewari
ENGINEER (Regd)	
SUPERVISOR (Regd)	
OWNER (Regd)	KIRAN DEVI
DEVELOPMENT AUTHORITY LOCAL BODY	

Building :A (RESEDENTIAL)

Floor Name	Total Built Up Area (Sq.mt.)	Proposed FAR Area (Sq.mt.) Resi.	Total FAR Area (Sq.mt.)	Total Consumed Additional FAR Area (Sq.mt.)	Tnmt (No.)
Ground And Parking Floor	28.59	28.59	28.59	28.59	01
First Floor	35.01	35.01	35.01	35.01	00
Second Floor	35.01	35.01	35.01	35.01	00
Terrace Floor	0.00	0.00	0.00	0.00	00
Total :	98.61	98.61	98.61	98.61	01
Total Number of Same Buildings	1				
Total :	98.61	98.61	98.61	98.61	01

SCHEDULE OF DOOR:

BUILDING NAME	NAME	LENGTH	HEIGHT	NOS
A (RESEDENTIAL)	D1	0.90	2.10	06

SCHEDULE OF WINDOW/VENTILATION:

BUILDING NAME	NAME	LENGTH	HEIGHT	NOS
A (RESEDENTIAL)	V	0.60	0.90	03
A (RESEDENTIAL)	W3	0.90	1.52	08
A (RESEDENTIAL)	W1	1.50	1.20	05

UnitBUA Table for Building :A (RESEDENTIAL)

FLOOR	Name	UnitBUA Type	UnitBUA Area	Carpet Area	No. of Rooms	No. of Tenement
GROUND AND PARKING FLOOR PLAN	SPLIT 1	FLAT	83.45	83.18	2	1
TYPICAL - 1, 2 FLOOR PLAN	SPLIT 1	FLAT	0.00	0.00	2	0
Total:	-	-	83.45	83.18	6	1

COLOR INDEX

PLOT BOUNDARY	[Red Line]
ABUTTING ROAD	[Green Line]
PROPOSED CONSTRUCTION	[Yellow Line]
COMMON PLOT	[Blue Line]
ROAD WIDENING AREA	[Orange Line]
EXISTING (To be retained)	[Black Line]
EXISTING (To be demolished)	[Grey Line]

Buildingwise Floor FAR Details

Floor Name	Building Name		Total	
	Proposed Built Up Area (Sq.mt.)	Proposed FAR Area (Sq.mt.)	Total Proposed Built Up Area (Sq.mt.)	Total FAR Area (Sq.mt.)
Ground And Parking Floor	28.59	28.59	28.59	28.59
First Floor	35.01	35.01	35.01	35.01
Second Floor	35.01	35.01	35.01	35.01
Terrace Floor	0.00	0.00	0.00	0.00
Total :	98.61	98.61	98.61	98.61

Building USE/SUBUSE Details

Building Name	Building Use	Building SubUse	Building Structure
A (RESEDENTIAL)	Residential	Bungalow/ Dwelling / Non Apartment	Non-Highrise

FAR & Tenement Details (Table 4c-1)

Building	No. of Same Bldg	Total Built Up Area (Sq.mt.)	Proposed FAR Area (Sq.mt.) Resi.	Total FAR Area (Sq.mt.)	Total Consumed Additional FAR Area (Sq.mt.)	Tnmt (No.)
A (RESEDENTIAL)	1	98.61	98.61	98.61	98.61	01
Grand Total:		98.61	98.61	98.61	98.61	01

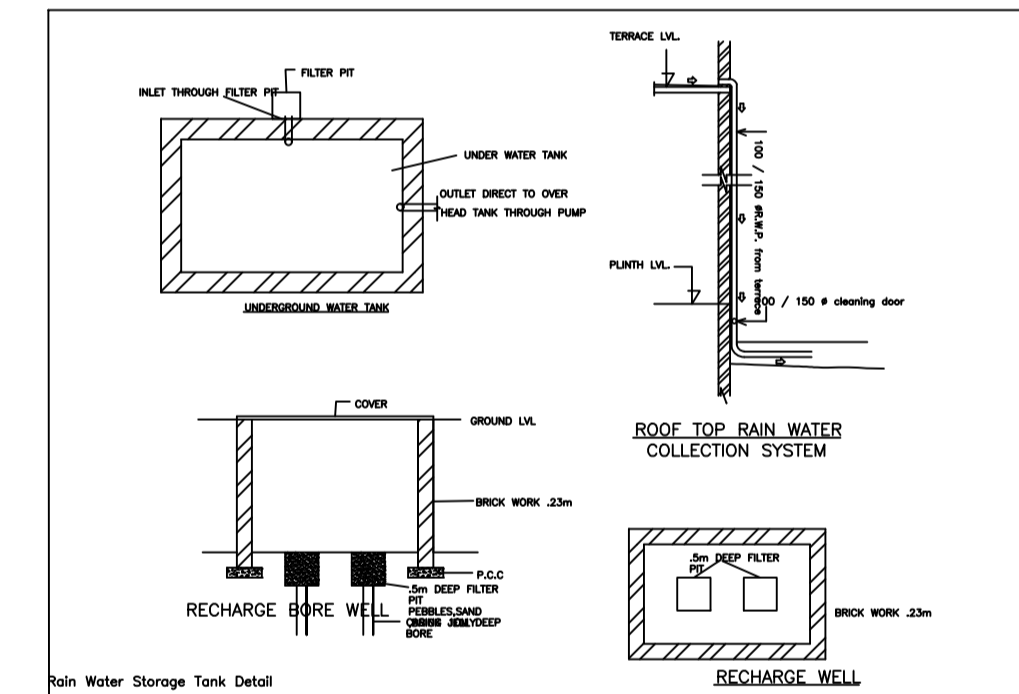
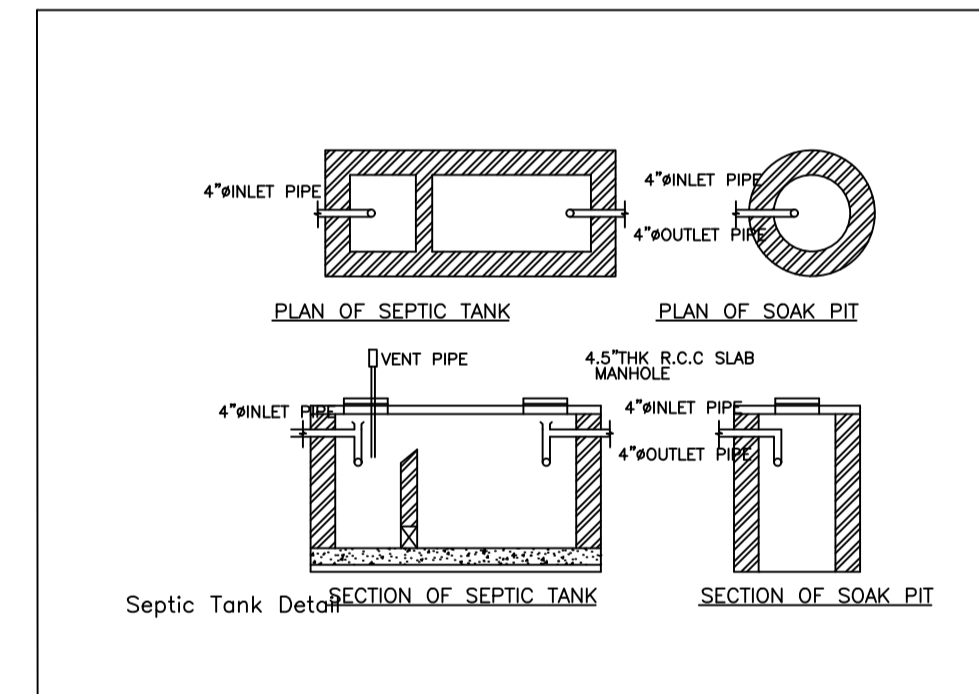
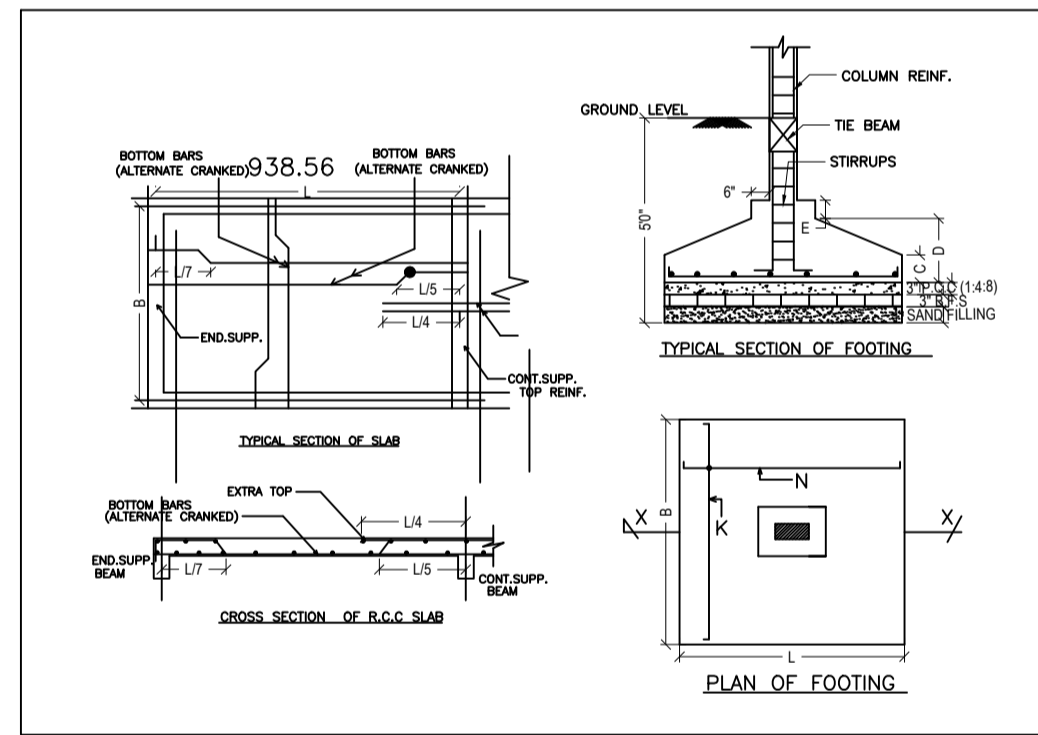
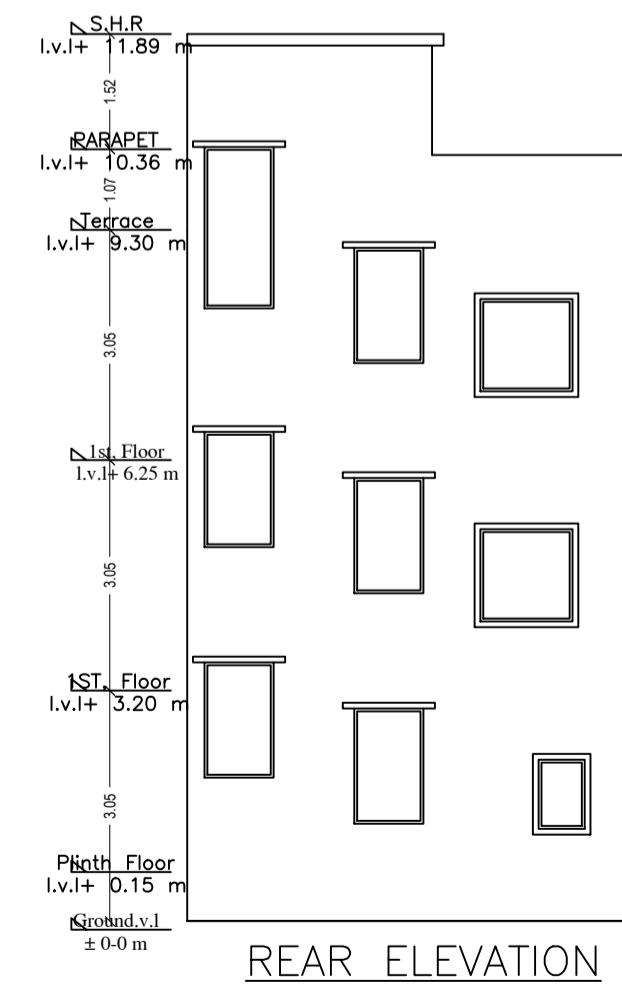
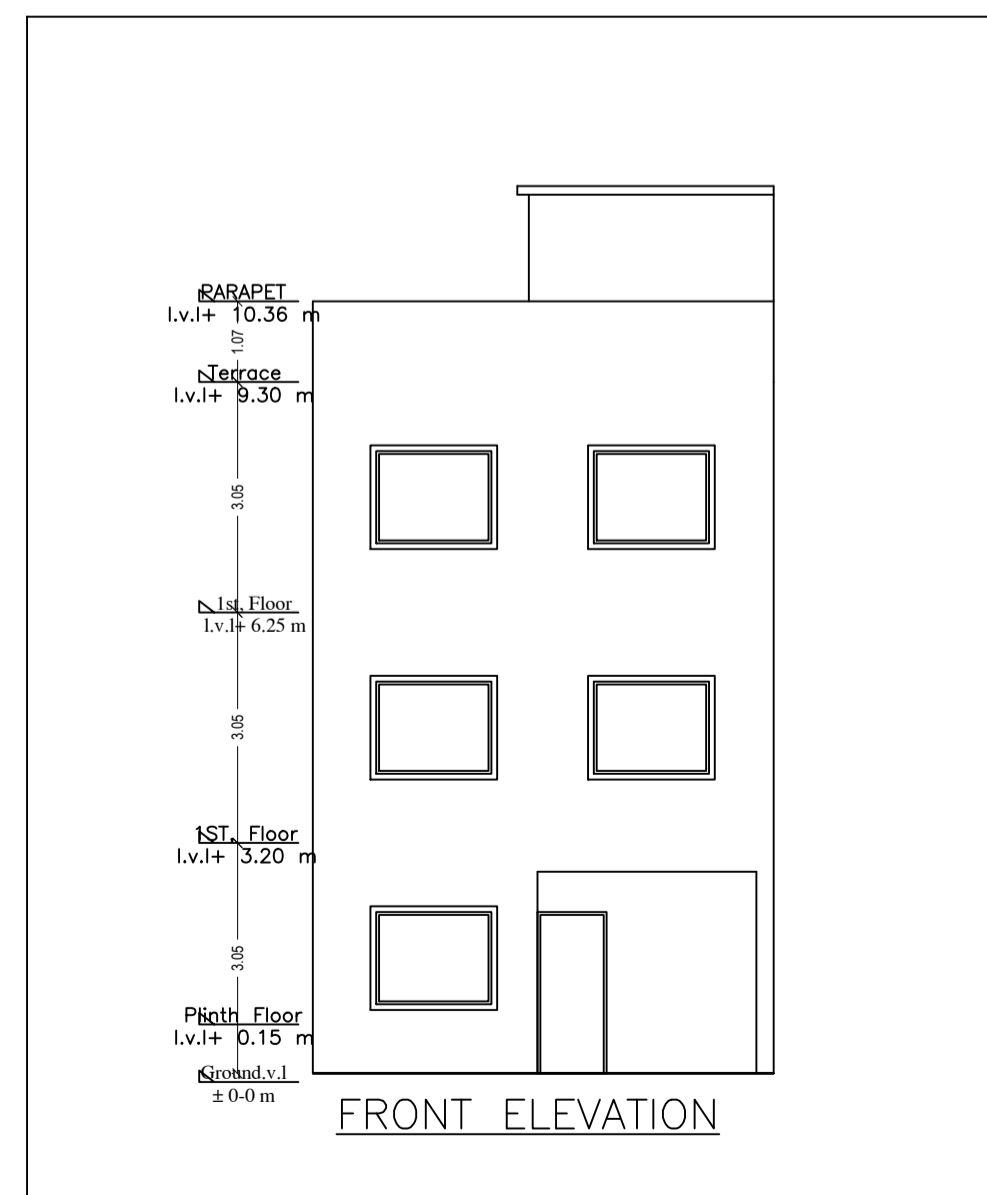
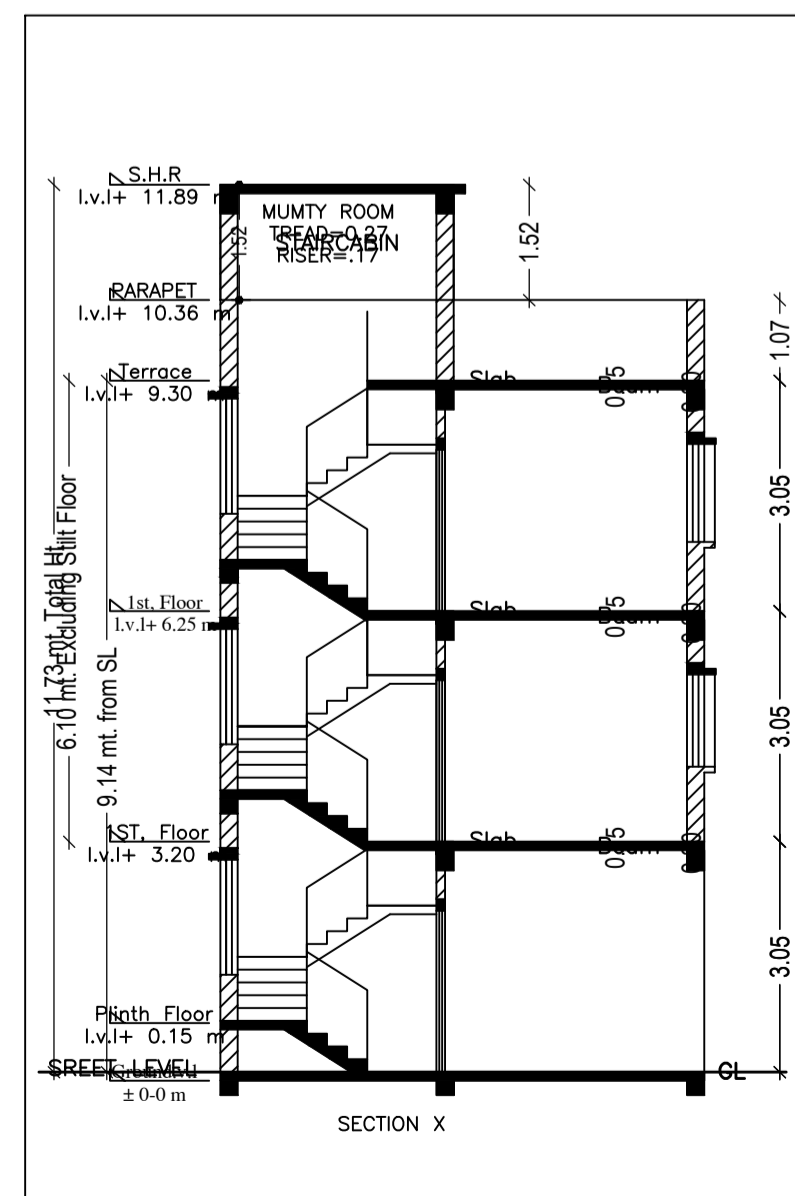

LTP NAME AND SIGNATURE	STRUCTURAL ENG'S NAME AND SIGNATURE	BUILDER NAME AND SIGNATURE	DIGITAL SIGNATURE
Abhishek Tewari JNAC/ARC/0007/2016			

Proposal Basic Information	
Proposal File No.	JNAC/BP/0086/W1/2023
Owner Name	KIRAN DEVI
Khata No	540
Plot No	255(p)
Village Name	SONARI
Use	Residential
SubUse	Bungalow/ Dwelling / Non Apartment

LTP NAME AND SIGNATURE	STRUCTURAL ENG'S NAME AND SIGNATURE	BUILDER NAME AND SIGNATURE	DIGITAL SIGNATURE
Abhishek Tewari JNAC/ARC/0007/2016			