

Proposal Basic Information

Proposal File No.	JNAC/BP/0056/W7/2024
Owner Name	SMT SHARDA DEVI , SRI SAMIR KUMAR SINGH AND SRI SUDHIR KUMAR SINGH
Khata No	H.NO. 7
Plot No	H.NO. 7
Village Name	GOLMURI
Use	Residential
SubUse	Bungalow/ Dwelling / Non Apartment

Building :A (SMT SHARDA DEVI AND OTHERS)

Floor Name	Total Built Up Area (Sq.mt.)	Deductions (Area in Sq.mt.)		Proposed FAR Area (Sq.mt.)	Add Area In FAR (Sq.mt.)	Total FAR Area (Sq.mt.)	Total Consumed Additional FAR Area (Sq.mt.)	Trmt (No.)
		Parking	Resi.					
Ground Floor	43.85	34.68	0.00	9.17	9.17	9.17	0.00	00
First Floor	43.85	0.00	43.85	0.00	43.85	43.85	0.00	01
Second Floor	43.85	0.00	43.85	0.00	43.85	43.85	0.00	00
Terrace Floor	0.00	0.00	0.00	0.00	0.00	0.00	0.00	00
<b>Total :</b>	<b>131.55</b>	<b>34.68</b>	<b>87.70</b>	<b>9.17</b>	<b>96.87</b>	<b>96.87</b>	<b>0.00</b>	<b>01</b>

AREA STATEMENT	VERSION NO.: 1.0.69
JAMSHEDPUR NAC	VERSION DATE: 16/10/2020
PROJECT DETAIL:	
Region: JHARKHAND URBAN LOCAL BODIES	Plot Use: Residential
District: EAST SINGHBHUM	Plot SubUse: Bungalow/ Dwelling / Non Apartment
Authority: JAMSHEDPUR NAC	Plot/Nearby/Religious Structure: NA
Inward No: JNAC/BP/0056/W7/2024	Plot/SubPlot No: H.NO. 7
Application Type: General Proposal	North: -
Project Type: Building Permission	South: -
Nature of Development: New	East: -
Location of Development Area: Old Area	West: Road Width - 8.0 MTR WIDE MAIN ROAD
AREA DETAILS:	
AREA OF PLOT (Minimum)	(A) 74.27
NET AREA OF PLOT (Gross Plot Area - Deduction from Gross Plot Area)	(A-Deductions) 74.27
Deduction for Balance Plot Area (from Gross Plot Area)	
Common Plot	12.70
Total	12.70
BALANCE AREA OF PLOT (Net Plot Area - Recreational/Amenity space)	(A-Deductions) 61.57
PLOT AREA FOR COVERAGE (Net Plot Area)	(A-Deductions) 74.27
Plot Area for FAR (Net Plot Area + Road Widening Area)	(A-Deductions) 74.27
COVERAGE CHECK	
Permissible Coverage area ( 70.00 % )	51.99
Proposed Coverage Area ( 59.04 % )	43.85
Total Prop. Coverage Area ( 59.04 % )	43.85
Balance coverage area ( 10.96 % )	8.14
FAR CHECK	
Perm. FAR Area ( 2.500 )	185.67
Total Perm. FAR area	185.67
Residential FAR	87.70
Proposed FAR Area	96.87
Total Proposed FAR Area	96.87
Consumed FAR (Factor)	1.30
Balance FAR Area	88.80
BUILT UP AREA CHECK	
Total Proposed BuiltUp Area	131.55
ARCHITECT (Regd) Amarjeet Balmuchu	
ENGINEER (Regd)	
SUPERVISOR (Regd)	
OWNER (Regd) SMT SHARDA DEVI , SRI SAMIR KUMAR SINGH AND SRI SUDHIR KUMAR SINGH	
DEVELOPMENT AUTHORITY LOCAL BODY	

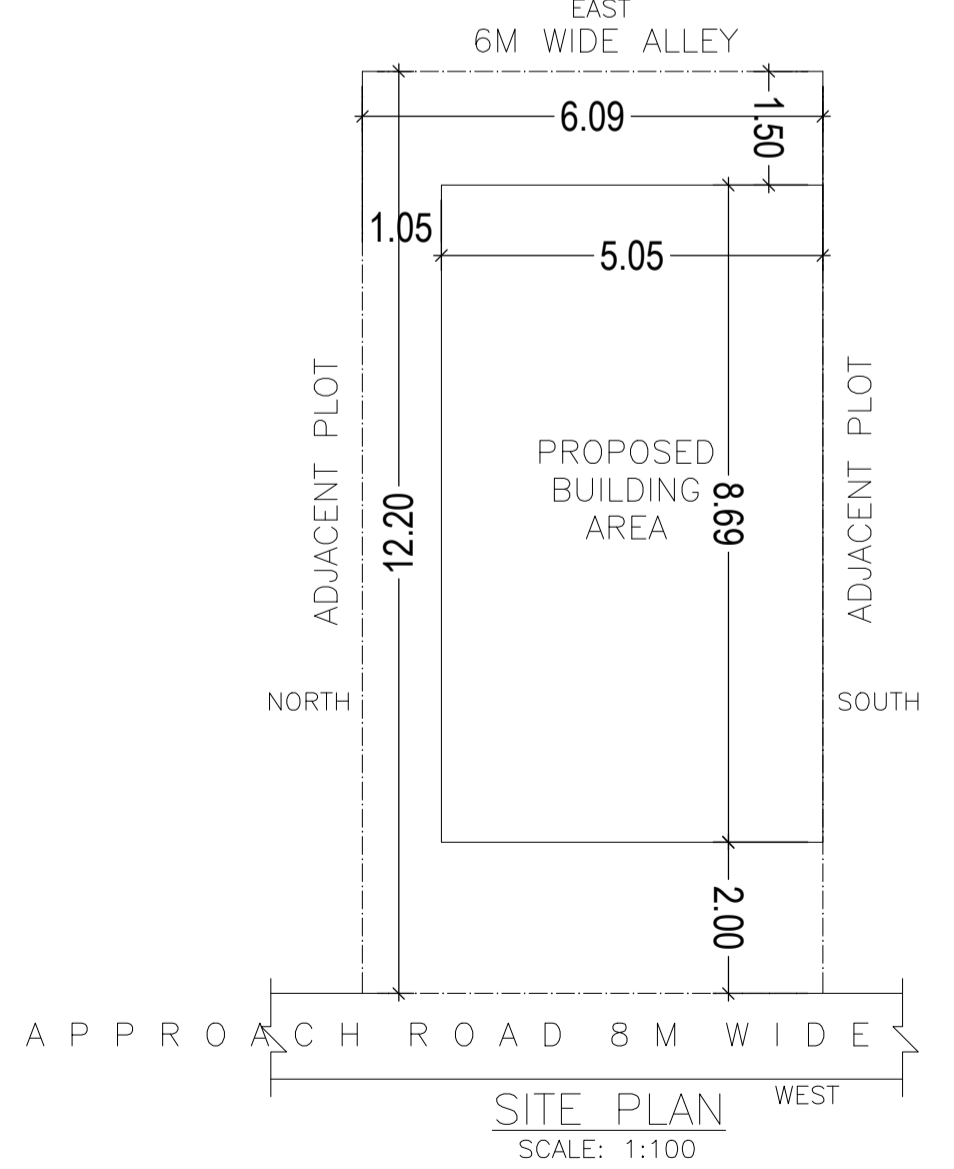
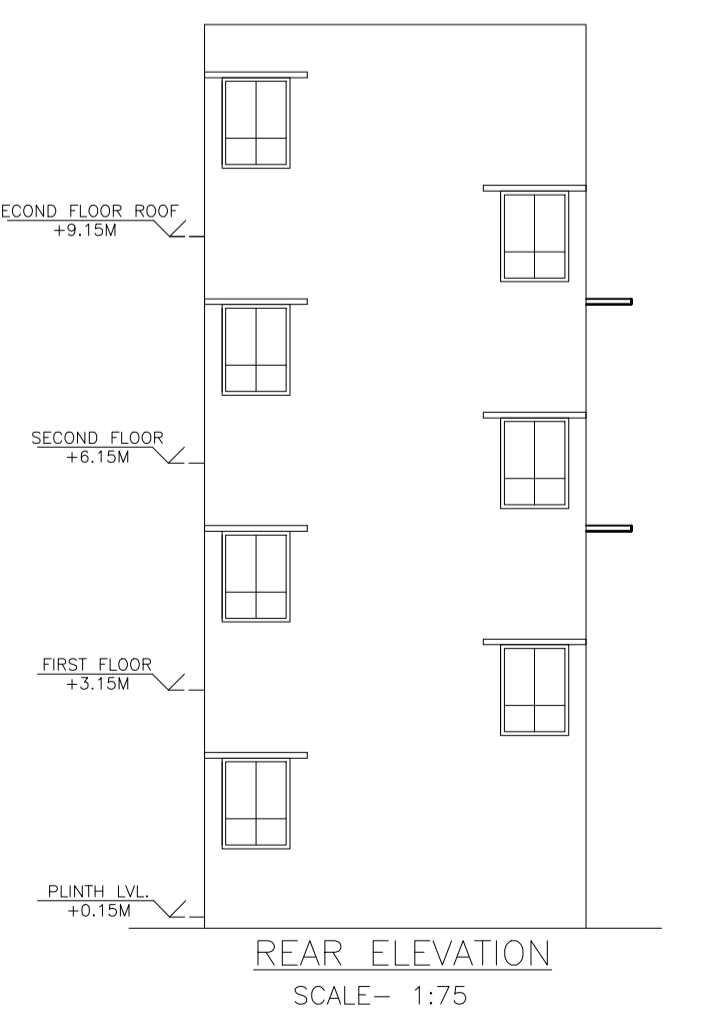
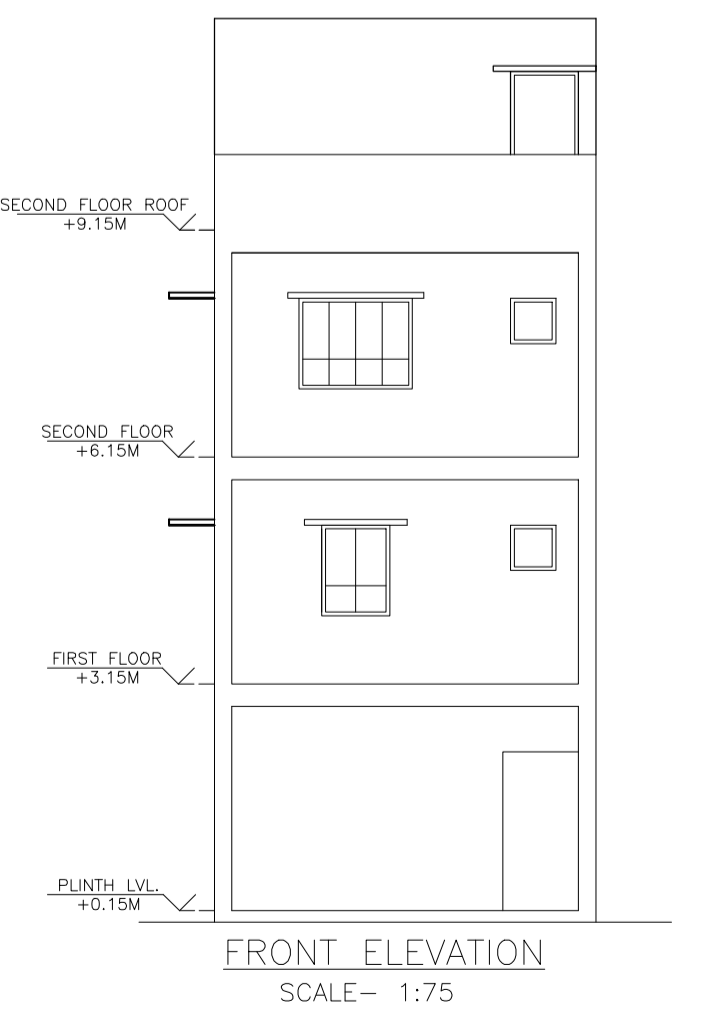
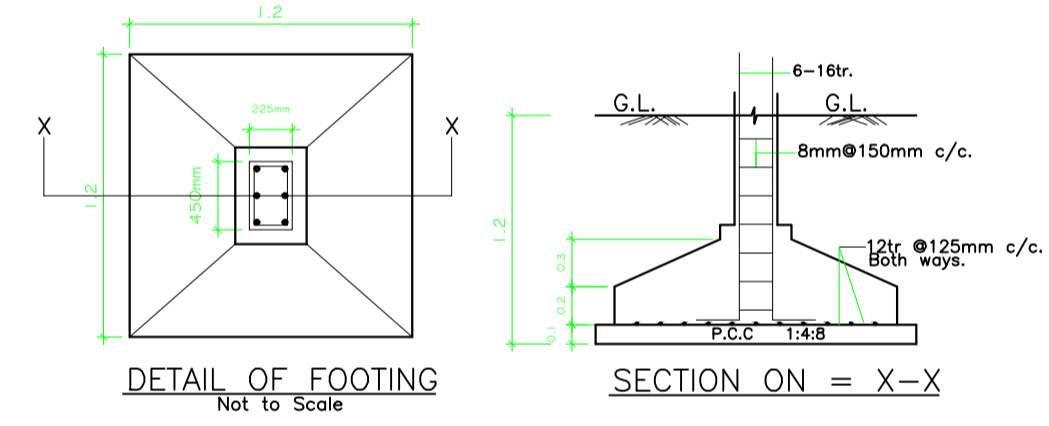
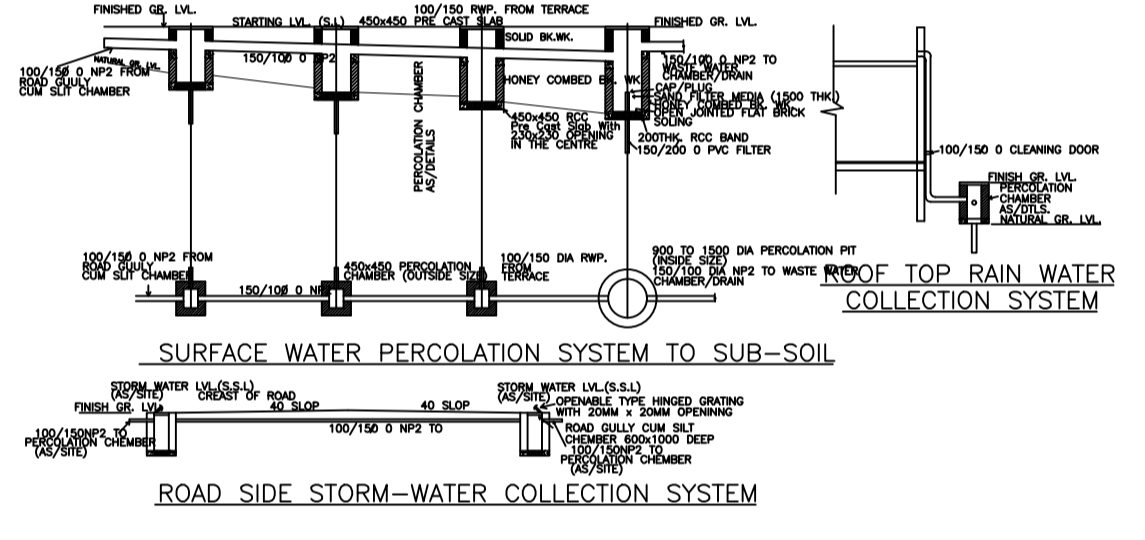
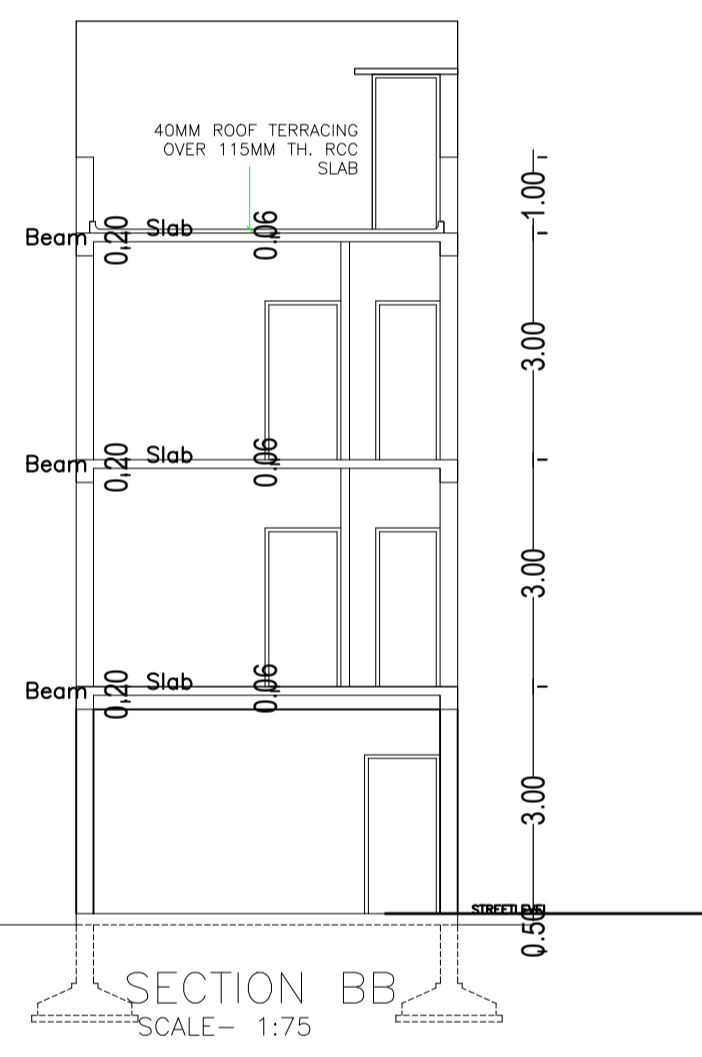
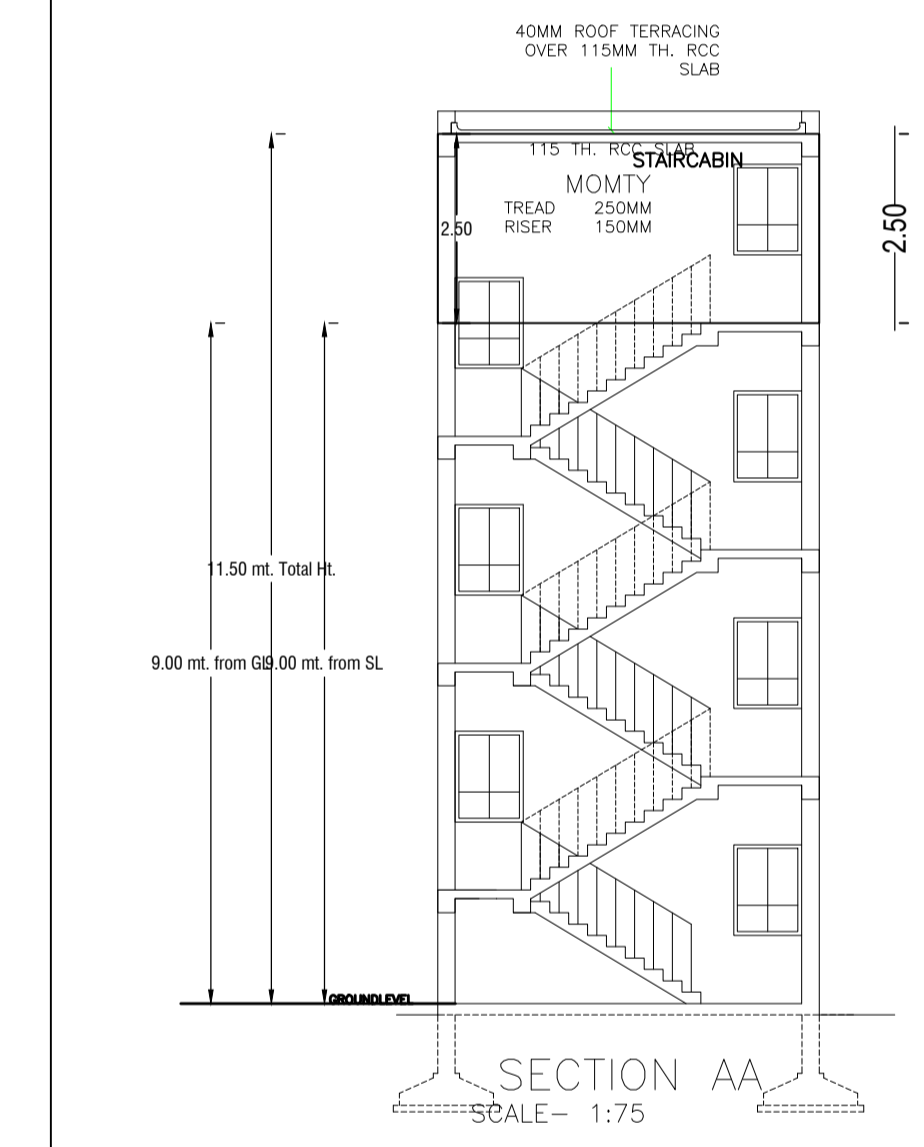
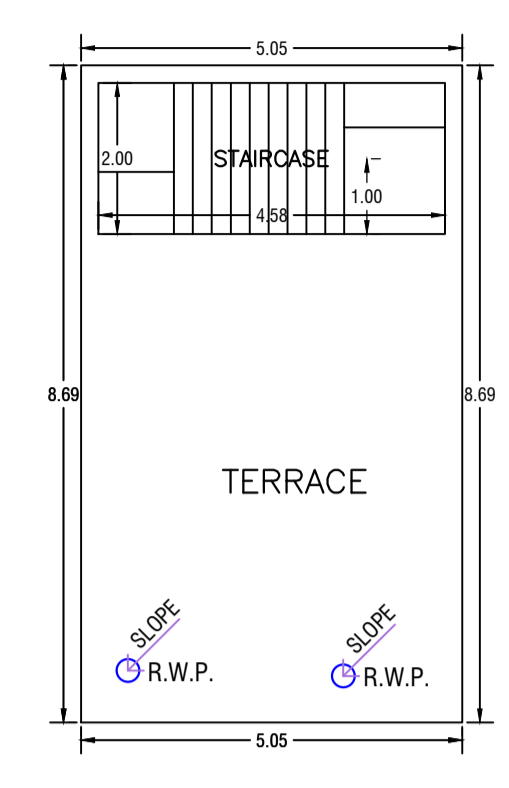
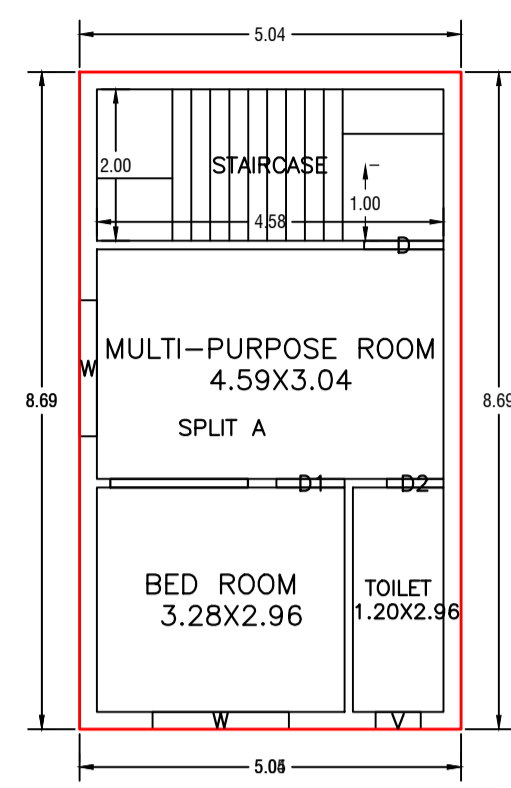
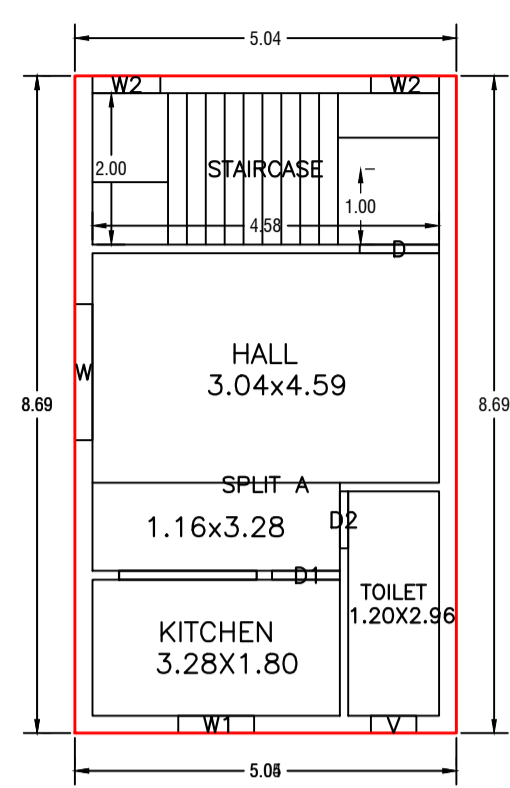
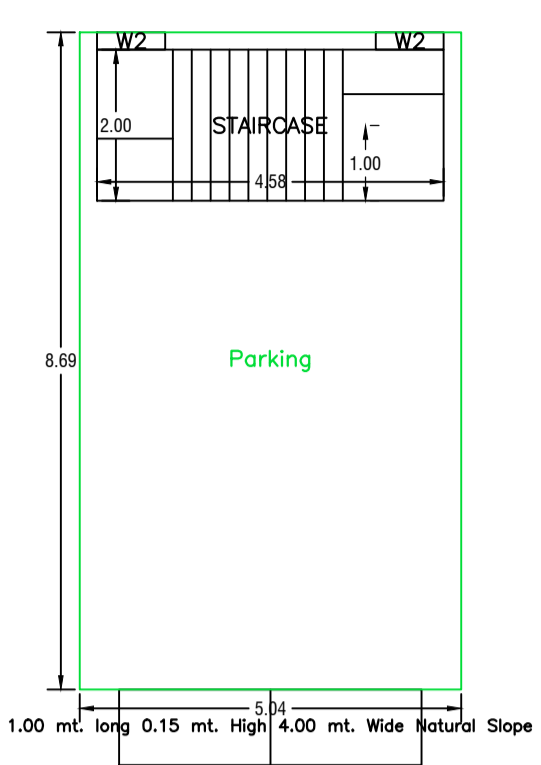
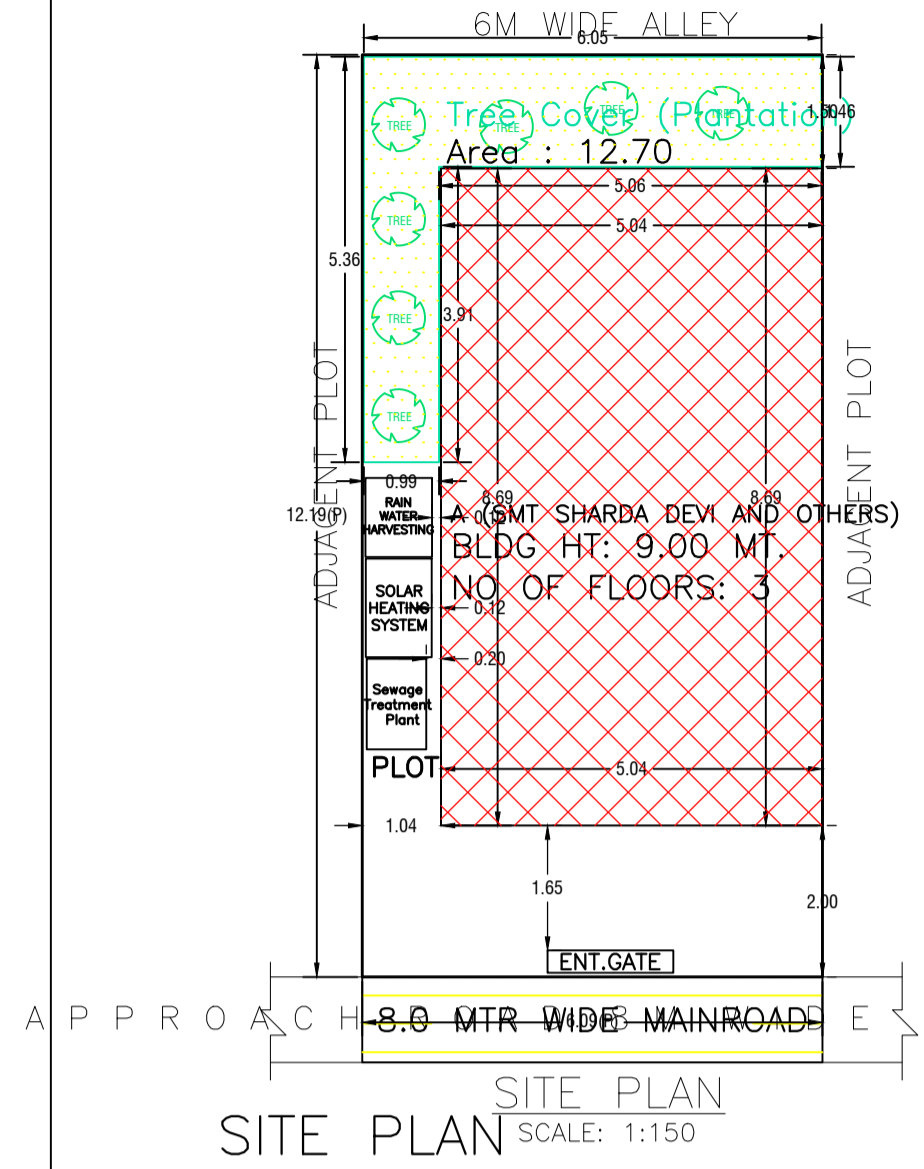

SCHEDULE OF DOOR:

BUILDING NAME	NAME	LENGTH	HEIGHT	NOS
A (SMT SHARDA DEVI AND OTHERS)	D2	0.75	2.13	02
A (SMT SHARDA DEVI AND OTHERS)	D1	0.90	2.13	02
A (SMT SHARDA DEVI AND OTHERS)	D	1.05	2.13	02

SCHEDULE OF WINDOW/VENTILATION:

BUILDING NAME	NAME	LENGTH	HEIGHT	NOS
A (SMT SHARDA DEVI AND OTHERS)	V	0.60	2.70	02
A (SMT SHARDA DEVI AND OTHERS)	W2	0.90	2.70	04
A (SMT SHARDA DEVI AND OTHERS)	W1	1.00	2.70	01
A (SMT SHARDA DEVI AND OTHERS)	W	1.80	2.70	03

UnitBUA Table for Building :A (SMT SHARDA DEVI AND OTHERS)

FLOOR	Name	UnitBUA Type	UnitBUA Area	Carpet Area	No. of Rooms	No. of Tenement
FIRST FLOOR PLAN	SPLIT A	FLAT	56.09	55.67	3	1
SECOND FLOOR PLAN	SPLIT A	FLAT	0.00	0.00	3	0
<b>Total:</b>	-	-	<b>56.09</b>	<b>55.67</b>	<b>6</b>	<b>1</b>

COLOR INDEX

PLOT BOUNDARY	Black
ABUTTING ROAD	Red
PROPOSED CONSTRUCTION	Green
COMMON PLOT	Yellow
ROAD WIDENING AREA	Blue
EXISTING (To be retained)	Orange
EXISTING (To be demolished)	Light Blue

Buildingwise Floor FAR Details

Floor Name	Building Name		Total	
	A (SMT SHARDA DEVI AND OTHERS) Proposed Built Up Area (Sq.mt.)	Proposed FAR Area (Sq.mt.)	Total Proposed Built Up Area (Sq.mt.)	Total FAR Area (Sq.mt.)
Ground Floor	43.85	9.17	43.85	9.17
First Floor	43.85	43.85	43.85	43.85
Second Floor	43.85	43.85	43.85	43.85
Terrace Floor	0.00	0.00	0.00	0.00
<b>Total :</b>	<b>131.55</b>	<b>96.87</b>	<b>131.55</b>	<b>96.87</b>

Building USE/SUBUSE Details

Building Name	Building Use	Building SubUse	Building Structure
A (SMT SHARDA DEVI AND OTHERS)	Residential	Bungalow/ Dwelling / Non Apartment	Non-Highrise

FAR & Tenement Details (Table 4c-1)

Building	No. of Same Bldg	Total Built Up Area (Sq.mt.)	Deductions (Area in Sq.mt.)		Proposed FAR Area (Sq.mt.)	Add Area In FAR (Sq.mt.)	Total FAR Area (Sq.mt.)	Total Consumed Additional FAR Area (Sq.mt.)	Trmt (No.)
			Parking	Resi.					
A (SMT SHARDA DEVI AND OTHERS)	1	131.55	34.68	87.70	9.17	96.87	96.87	0.00	01
<b>Grand Total :</b>	<b>1</b>	<b>131.55</b>	<b>34.68</b>	<b>87.70</b>	<b>9.17</b>	<b>96.87</b>	<b>96.87</b>	<b>0.00</b>	<b>01</b>

LTP NAME AND SIGNATURE Amarjeet Balmuchu JNAC/ARC/0008/2018	STRUCTURAL ENG'S NAME AND SIGNATURE	BUILDER NAME AND SIGNATURE	DIGITAL SIGNATURE
---	-------------------------------------	----------------------------	-------------------