

Building :A (GHAYUR ALAM AND OTHERS)

Floor Name	Total Built Up Area (Sq.mt.)	Deductions (Area in Sq.mt.)		Proposed FAR Area (Sq.mt.)	Add Area In FAR (Sq.mt.)	Total FAR Area (Sq.mt.)	Total Consumed Additional FAR Area (Sq.mt.)	Tnmt (No.)
		Parking	Resi.					
Parking Floor	45.13	33.78	0.00	11.35	11.35	11.35	0.00	00
First Floor	45.13	0.00	45.13	0.00	45.13	45.13	45.13	01
Second Floor	45.13	0.00	45.13	0.00	45.13	45.13	45.13	00
Terrace Floor	0.00	0.00	0.00	0.00	0.00	0.00	0.00	00
Total :	135.39	33.78	90.26	11.35	101.61	101.61	101.61	01
Total Number of Same Buildings	1							
Total :	135.39	33.78	90.26	11.35	101.61	101.61	101.61	01

SCHEDULE OF DOOR:

BUILDING NAME	NAME	LENGTH	HEIGHT	NOS
A (GHAYUR ALAM AND OTHERS)	D3	0.80	2.10	04
A (GHAYUR ALAM AND OTHERS)	D2	0.90	2.10	01
A (GHAYUR ALAM AND OTHERS)	D1	1.20	2.10	02

SCHEDULE OF WINDOW/VENTILATION:

BUILDING NAME	NAME	LENGTH	HEIGHT	NOS
A (GHAYUR ALAM AND OTHERS)	V	0.60	0.60	02
A (GHAYUR ALAM AND OTHERS)	W4	0.90	1.20	01
A (GHAYUR ALAM AND OTHERS)	W3	1.20	1.20	04
A (GHAYUR ALAM AND OTHERS)	W2	1.50	1.20	01
A (GHAYUR ALAM AND OTHERS)	W1	1.80	1.20	01
A (GHAYUR ALAM AND OTHERS)	W1	2.40	1.20	01

UnitBUA Table for Building :A (GHAYUR ALAM AND OTHERS)

FLOOR	Name	UnitBUA Type	UnitBUA Area	Carpet Area	No. of Rooms	No. of Tenement
FIRST FLOOR PLAN	SPLIT A	FLAT	90.25	80.95	4	1
SECOND FLOOR PLAN	SPLIT A	FLAT	0.00	0.00	3	0
Total:			90.25	80.95	7	1

Proposal Basic Information

Proposal File No.	JNAC/BP/0006/W7/2024
Owner Name	GHAYUR ALAM AND MD JHANGIR ALAM AND MD IRSAD ALAM AND SRI MANZOOR ALAM
Khata No	245
Plot No	H.NO - 939
Village Name	SAKCHI
Use	Residential
SubUse	Semidetached

AREA STATEMENT		VERSION NO. : 1.0.68
JAMSHEDPUR NAC		VERSION DATE: 16/10/2020
PROJECT DETAIL:		
Region: JHARKHAND URBAN LOCAL BODIES	Plot Use: Residential	
District: EAST SINGHBHUM	Plot SubUse: Semidetached	
Authority: JAMSHEDPUR NAC	Plot/Nearby/Religious/Structure: NA	
Inward No. JNAC/BP/0006/W7/2024	Plot/SubPlot No: H.NO - 939	
Application Type: General Proposal	North: Plot No. - 940	
Project Type: Building Permission	South: Plot No. - 938	
Nature of Development: New	East: Road Width - 6.25 M	
Location of Development Area: Old Area	West: Road Width - 4.5 M	
AREA DETAILS:		
AREA OF PLOT (Minimum)	(A)	SQ.MT. 72.27
NET AREA OF PLOT (Gross Plot Area - Deduction from Gross Plot area)	(A-Deductions)	72.27
Deduction for Balance Plot Area (from Gross Plot Area)		
Common Plot		7.15
Total		7.15
BALANCE AREA OF PLOT (Net Plot Area - Recreational/Amenity space)	(A-Deductions)	65.12
PLOT AREA FOR COVERAGE (Net Plot Area)	(A-Deductions)	72.27
Plot Area for FAR (Net Plot Area + Road/Widening Area)	(A-Deductions)	72.27
COVERAGE CHECK		
Permissible Coverage area (70.00 %)		50.59
Proposed Coverage Area (62.45 %)		45.13
Total Prop. Coverage Area (62.45 %)		45.13
Balance coverage area (7.56 %)		5.46
FAR CHECK		
Perm. FAR Area (2.500)		180.67
Total Perm. FAR area		180.67
Residential FAR		90.25
Proposed FAR Area		101.61
Total Proposed FAR Area		101.61
Consumed FAR (Factor)		1.41
Balance FAR Area		79.06
BUILT UP AREA CHECK		
Total Proposed BuiltUp Area		135.39
ARCHITECT (Regd)	SHREYASHI PAUL	
ENGINEER (Regd)		
SUPERVISOR (Regd)		
OWNER (Regd)	GHAYUR ALAM AND MD JHANGIR ALAM AND MD IRSAD ALAM AND SRI MANZOOR ALAM	
DEVELOPMENT AUTHORITY		LOCAL BODY

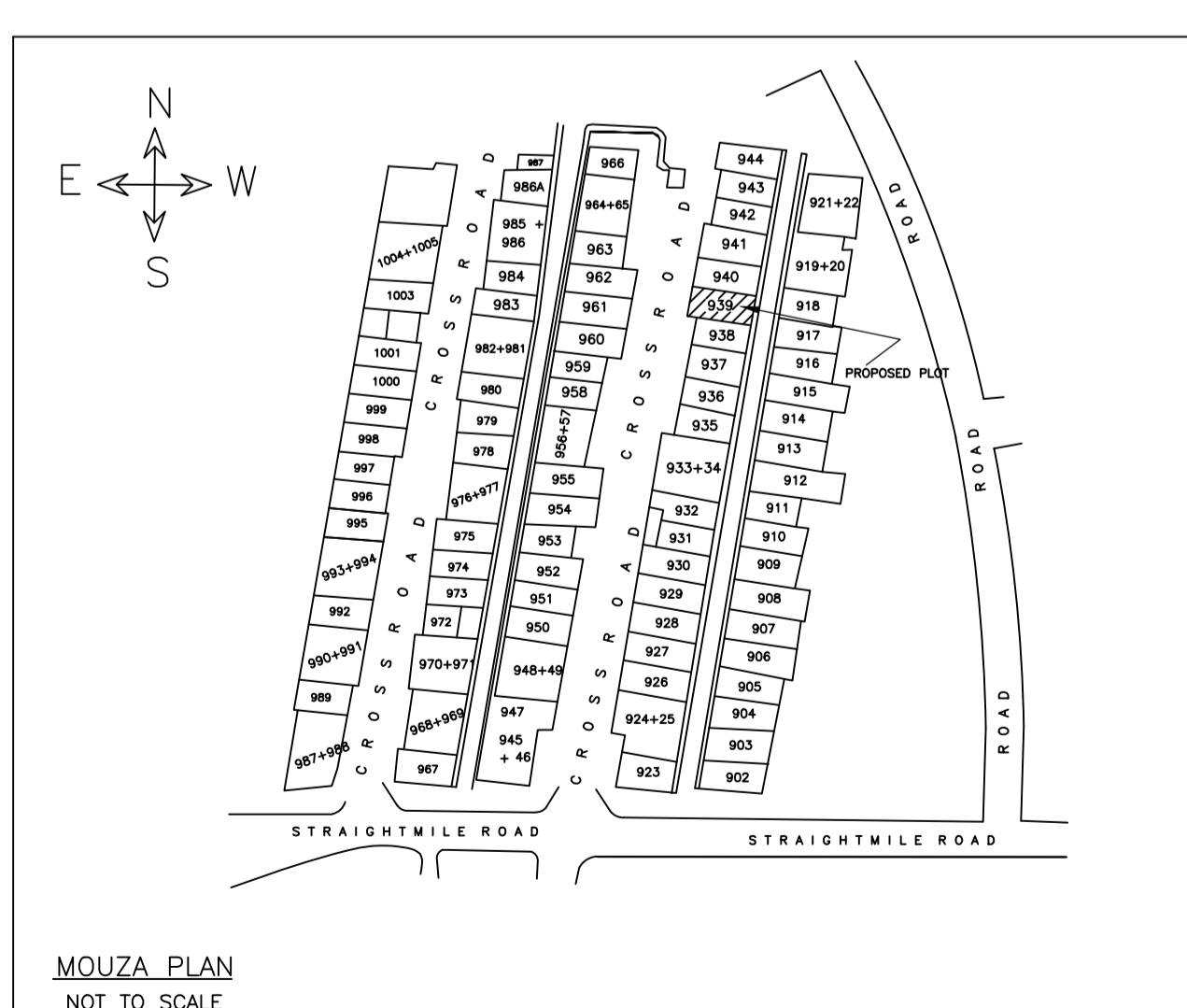
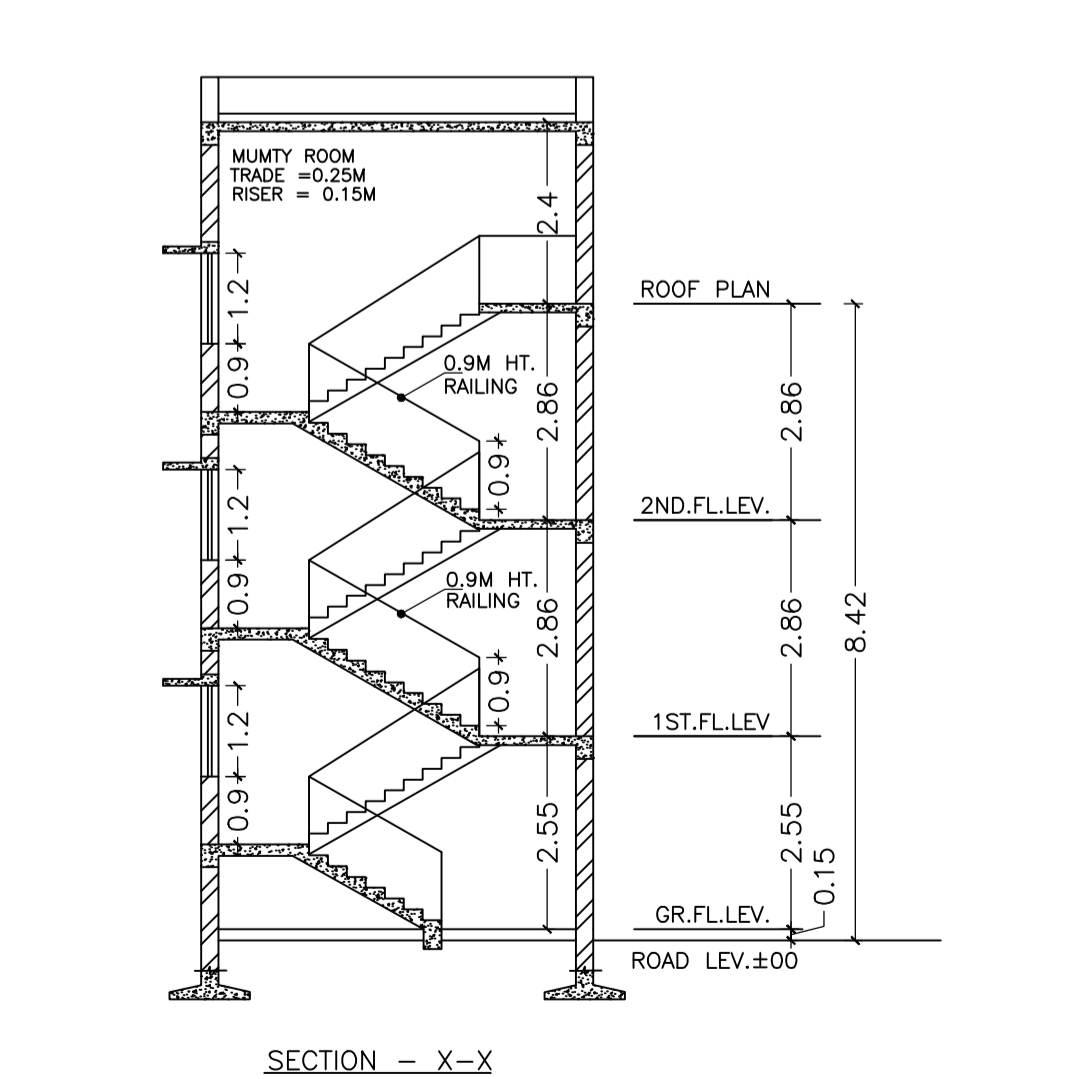
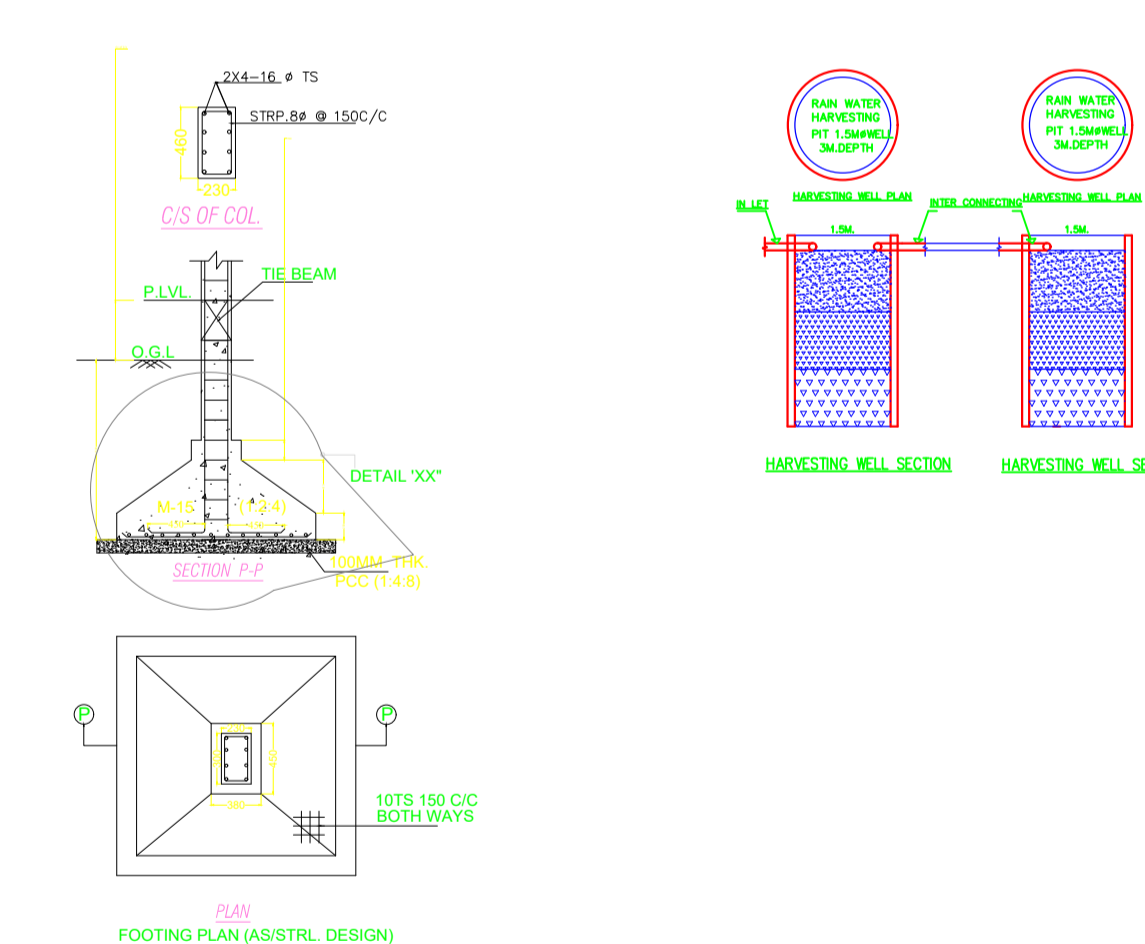
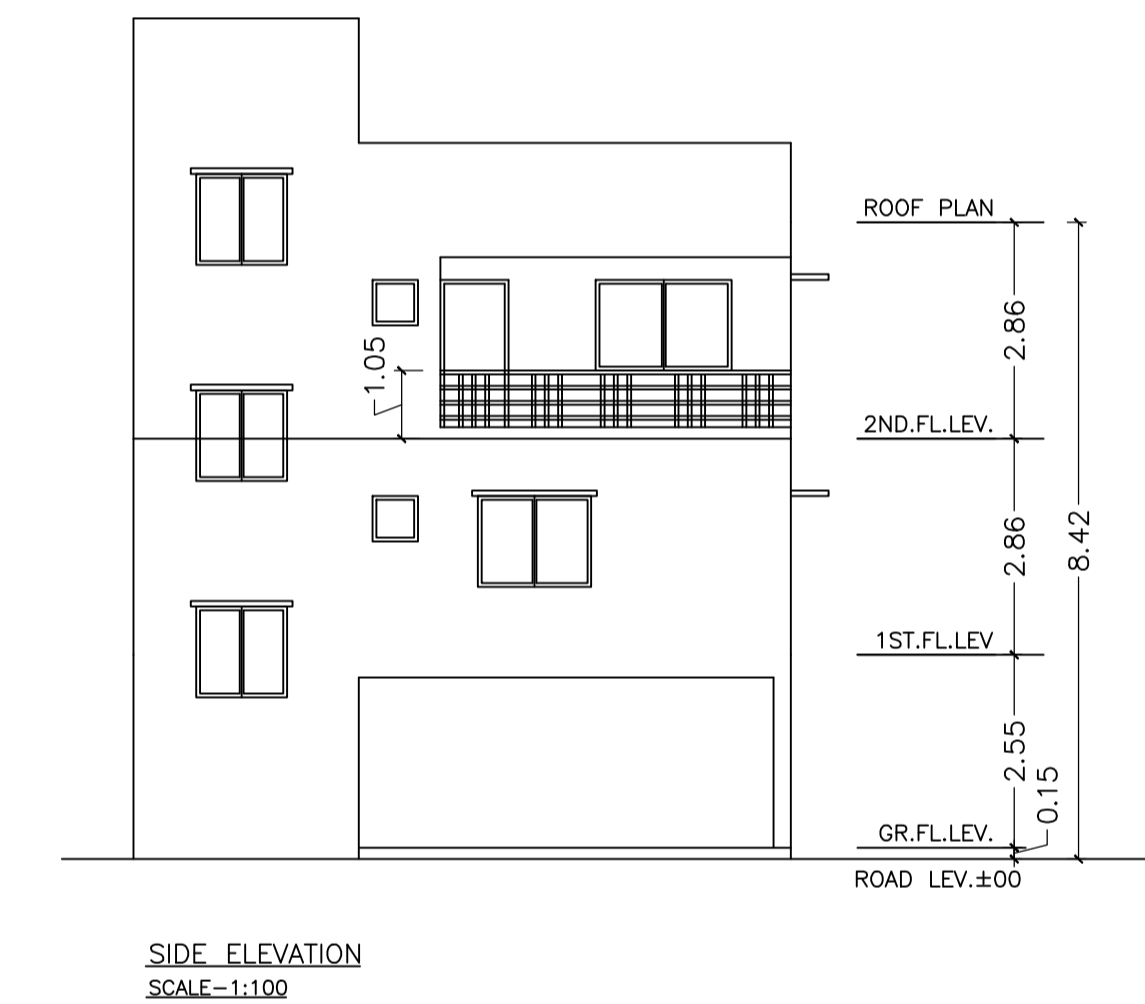
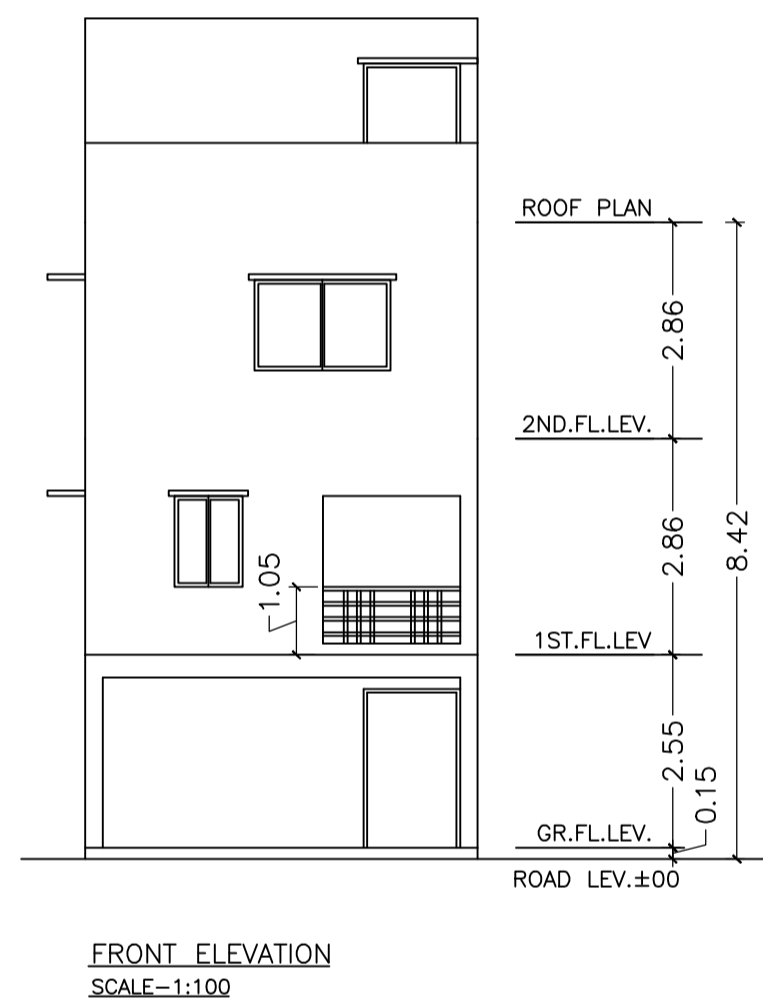
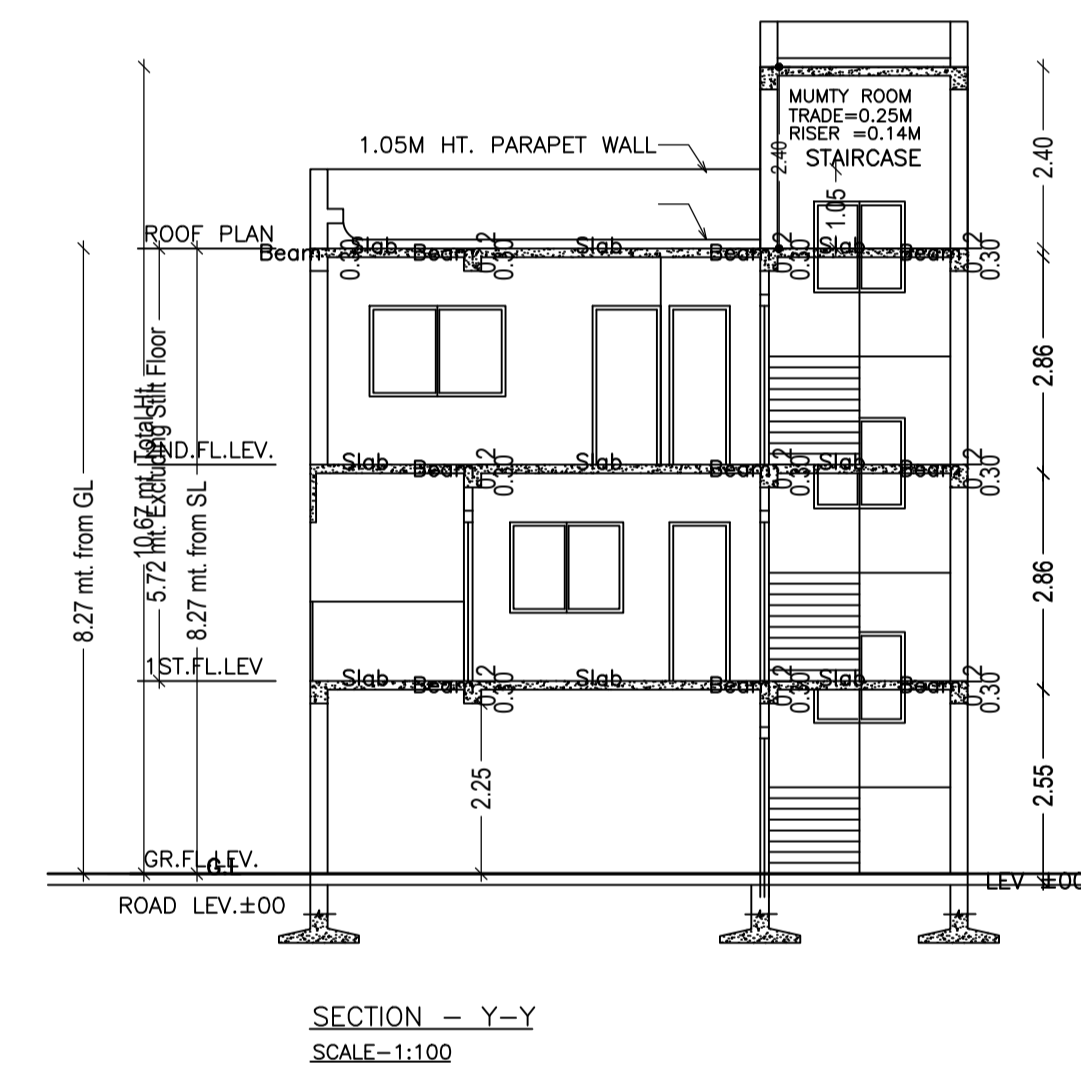

COLOR INDEX	
PLOT BOUNDARY	Black
ABUTTING ROAD	Green
PROPOSED CONSTRUCTION	Red
COMMON PLOT	Yellow
ROAD WIDENING AREA	Blue
EXISTING (To be retained)	Light Blue
EXISTING (To be demolished)	Dark Blue

Buildingwise Floor FAR Details

Floor Name	Building Name		Total	
	A (GHAYUR ALAM AND OTHERS) Proposed Built Up Area (Sq.mt.)	Proposed FAR Area (Sq.mt.)	Total Proposed Built Up Area (Sq.mt.)	Total FAR Area (Sq.mt.)
Parking Floor	45.13		45.13	11.35
First Floor	45.13		45.13	45.13
Second Floor	45.13	45.13	45.13	45.13
Terrace Floor	0.00	0.00	0.00	0.00
Total :	135.39	101.61	135.39	101.61

Building USE/SUBUSE Details

Building Name	Building Use	Building SubUse	Building Structure
A (GHAYUR ALAM AND OTHERS)	Residential	Semidetached	Non-Highrise

FAR & Tenement Details (Table 4c-1)

Building	No. of Same Bldg	Total Built Up Area (Sq.mt.)	Deductions (Area in Sq.mt.)		Proposed FAR Area (Sq.mt.)	Add Area In FAR (Sq.mt.)	Total FAR Area (Sq.mt.)	Total Consumed Additional FAR Area (Sq.mt.)	Tnmt (No.)
			Parking	Resi.					
A (GHAYUR ALAM AND OTHERS)	1	135.39	33.78	90.26	11.35	101.61	101.61	101.61	01
Grand Total :	1	135.39	33.78	90.26	11.35	101.61	101.61	101.61	01

LTP NAME AND SIGNATURE	STRUCTURAL ENG'S NAME AND SIGNATURE	BUILDER NAME AND SIGNATURE	DIGITAL SIGNATURE
SHREYASHI PAUL JNAC/DFT/MN/0009/2016			