

FAR & Tenement Details (Table 4c-1)

Building	No. of Same Bldg	Total Built Up Area (Sq.mt.)	Deductions (Area in Sq.mt.)	Proposed FAR Area (Sq.mt.)	Add Area In FAR (Sq.mt.)	Total FAR Area (Sq.mt.)	Total Consumed Additional FAR Area (Sq.mt.)	Tnmt (No.)
A (SMT SHILA SINHA)	1	214.68	55.33	143.12	16.23	159.35	159.35	02
Grand Total :	1	214.68	55.33	143.12	16.23	159.35	159.35	02

Proposal Basic Information

Proposal File No.	JNAC/BI/0088/W2/2024
Owner Name	SMT. SHILA SINHA
Khata No	NIL
Plot No	NIL
Village Name	SONARI
Use	Residential
SubUse	Bungalow/ Dwelling / Non Apartment

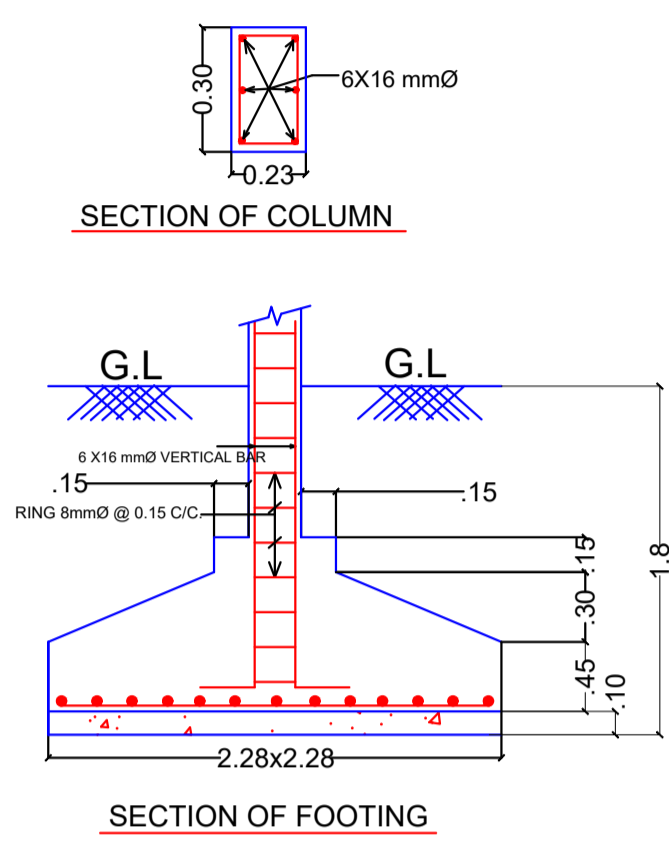

PARKING FLOOR PLAN (SCALE 1:100)

TYPICAL - 1 & 2 FLOOR PLAN (Proposed) (SCALE 1:100)

TERRACE FLOOR PLAN (SCALE 1:100)

SITE PLAN SCALE=1:100

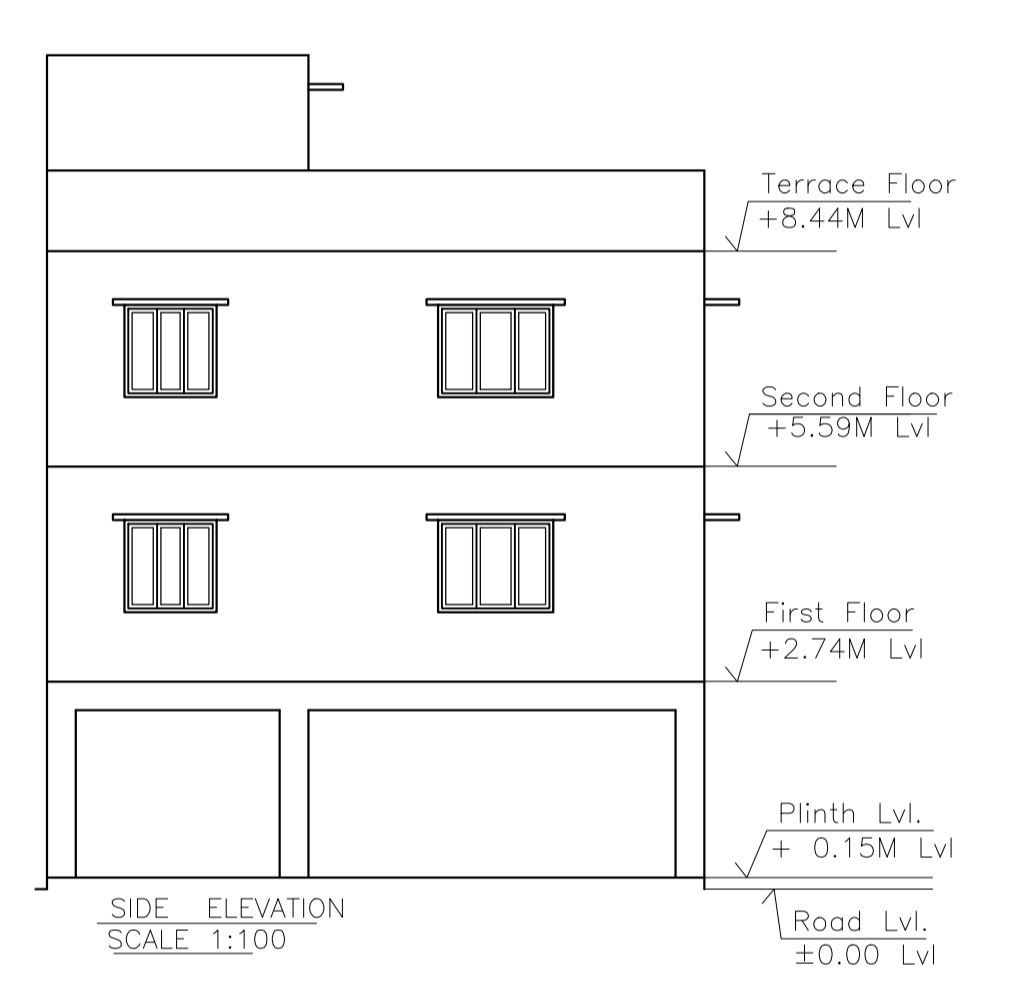
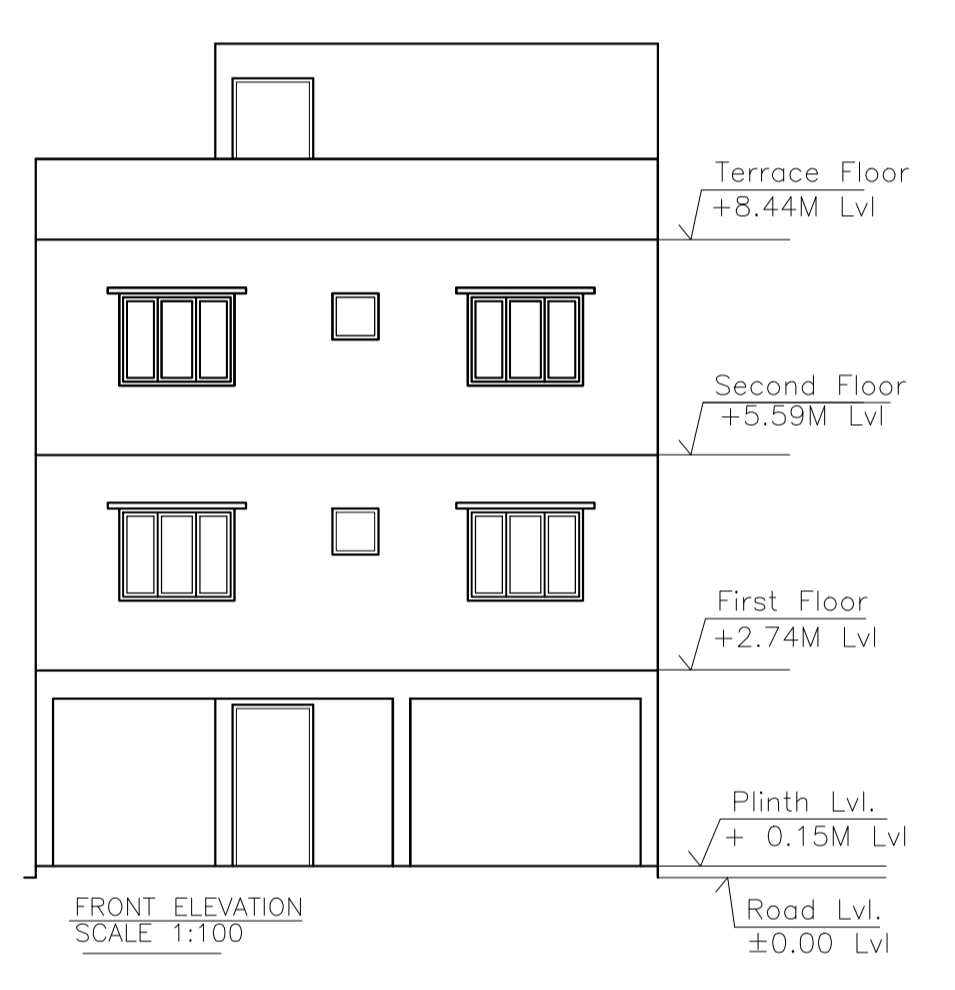
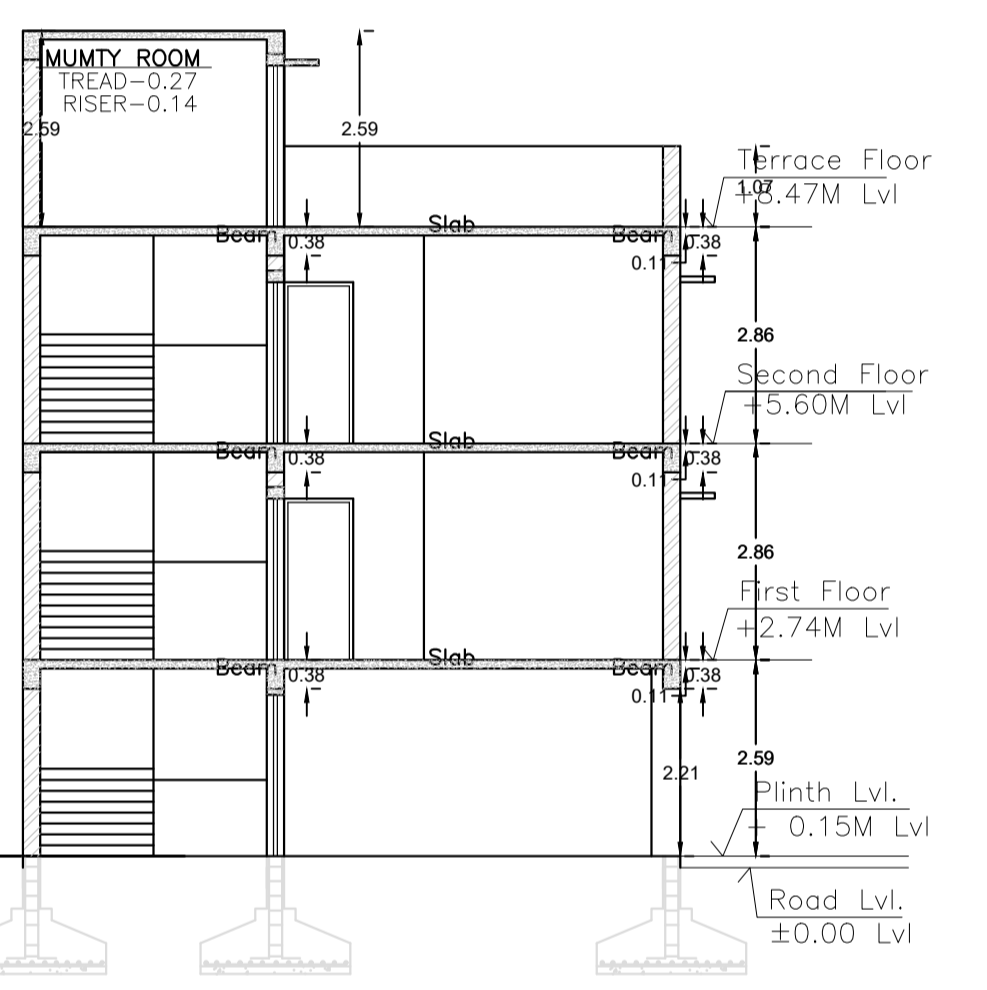
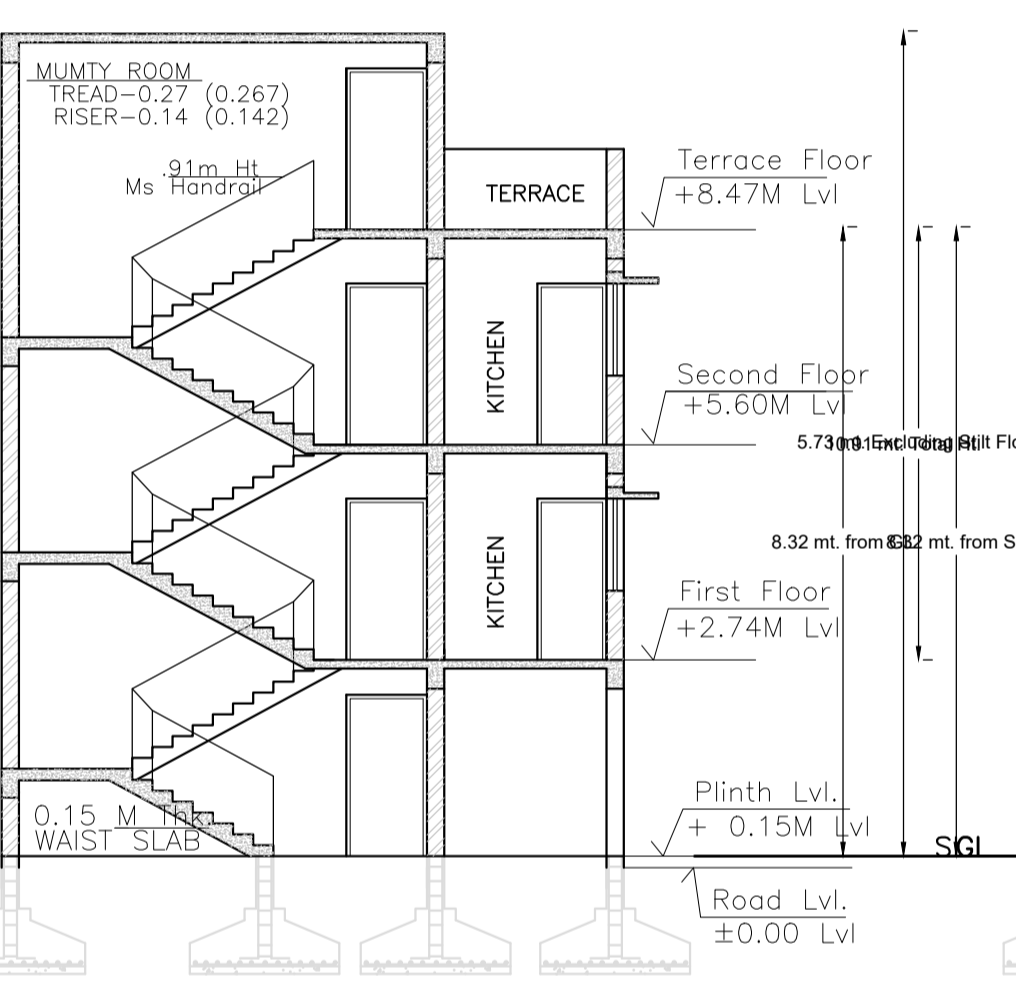

SCALE=1:100

SECTION AT Y-Y SCALE=1:100

FRONT ELEVATION SCALE 1:100

SIDE ELEVATION SCALE 1:100

AREA STATEMENT	JAMSHEDPUR NAC	VERSION NO.: 1.0.72	
LOCAL BODIES		VERSION DATE: 16/10/2020	
PROJECT DETAIL:			
Region:	JHARKHAND URBAN	Plot Use:	Residential
District:	EAST SINGHBHUM	Plot SubUse:	Bungalow/ Dwelling / Non Apartment
Authority:	JAMSHEDPUR NAC	Plot/Nearby/Religious/Structure:	NA
Inward No.:	JNAC/BI/0088/W2/2024	Plot/SubPlot No.:	NIL
Application Type:	General Proposal	North:	Survey No. - E/541
Project Type:	Building Permission	South:	Survey No. - E/539
Nature of Development:	New	East:	Survey No. - ALLEY
Location of Development Area:	Old Area	West:	Road Width - 9.5
AREA OF PLOT (Minimum)	(A)		SQ.MT.
NET AREA OF PLOT (Gross Plot Area - Deduction from Gross Plot area)	(A-Deductions)		111.41
Deduction for Balance Plot Area (from Gross Plot Area)			
Common Plot			19.54
Balance AREA OF PLOT (Net Plot Area - Recreational/Amenity space)	(A-Deductions)		91.87
PLOT AREA FOR COVERAGE (Net Plot Area)	(A-Deductions)		111.41
Plot Area for FAR (Net Plot Area + Road Widening Area)	(A-Deductions)		111.41
COVERAGE CHECK			
Permissible Coverage area (70.00 %)			77.99
Proposed Coverage Area (64.23 %)			71.56
Total Prop. Coverage Area (64.23 %)			71.56
Balance coverage area (5.77 %)			6.43
FAR CHECK			
Perm. FAR Area (2,500)			278.53
Total Perm. FAR area			278.53
Residential FAR			143.13
Proposed FAR Area			159.36
Total Proposed FAR Area			159.36
Consumed FAR (Factor)			1.43
Balance FAR Area			119.17
BUILT UP AREA CHECK			
Total Proposed Built Up Area			214.68
ARCHITECT (Regd)			NABANITA BHATTACHERYA
ENGINEER (Regd)			
SUPERVISOR (Regd)			
OWNER (Regd)			SMT. SHILA SINHA
DEVELOPMENT AUTHORITY LOCAL BODY			

COLOR INDEX

PLOT BOUNDARY	Black
ABUTTING ROAD	Green
PROPOSED CONSTRUCTION	Red
COMMON PLOT	Yellow
ROAD WIDENING AREA	Orange
EXISTING (To be retained)	Blue
EXISTING (To be demolished)	Pink

Building :A (SMT SHILA SINHA)

Floor Name	Total Built Up Area (Sq.mt.)	Deductions (Area in Sq.mt.)		Proposed FAR Area (Sq.mt.)	Add Area In FAR (Sq.mt.)	Total FAR Area (Sq.mt.)	Total Consumed Additional FAR Area (Sq.mt.)	Tnmt (No.)
		Parking	Resi.					
Parking Floor	71.56	55.33	0.00	16.23	16.23	16.23	00	
First Floor	71.56	0.00	71.56	0.00	71.56	71.56	01	
Second Floor	71.56	0.00	71.56	0.00	71.56	71.56	01	
Terrace Floor	0.00	0.00	0.00	0.00	0.00	0.00	00	
Total :	214.68	55.33	143.12	16.23	159.35	159.35	02	

SCHEDULE OF DOOR:

BUILDING NAME	NAME	LENGTH	HEIGHT	NOS
A (SMT SHILA SINHA)	D2	0.75	2.10	02
A (SMT SHILA SINHA)	D1	0.90	2.10	04
A (SMT SHILA SINHA)	D	1.07	2.10	02

SCHEDULE OF WINDOW/VENTILATION:

BUILDING NAME	NAME	LENGTH	HEIGHT	NOS
A (SMT SHILA SINHA)	V	0.60	1.20	02
A (SMT SHILA SINHA)	W1	1.20	1.20	03
A (SMT SHILA SINHA)	W1	1.22	1.20	02
A (SMT SHILA SINHA)	W	1.50	1.20	06

UnitBUA Table for Building :A (SMT SHILA SINHA)

FLOOR	Name	UnitBUA Type	UnitBUA Area	Carpet Area	No. of Rooms	No. of Tenement
TYPICAL - 1 & 2 FLOOR PLAN	A	FLAT	71.56	63.00	5	2
Total:	-	-	143.13	126.00	10	2



LOCATION PLAN (SCALE=nts)

Required Parking (Table 7a)

Building Name	Type	SubUse	Area (Sq.mt.)	Units	Car		Visitors Car		TwoWheeler	
					Reqd.	Prop.	Reqd./Unit	Prop.	Reqd./Unit	Prop.
A (SMT SHILA SINHA)	Residential	Bungalow/ Dwelling / Non Apartment	> 0	1	2.00	1.00	2	-	-	-
Total :		-	-	-	-	2	2	-	1	1

Parking Check (Table 7b)

Vehicle Type	Reqd.		Prop.	
	No.	Area	No.	Area
Car	-	-	2	25.00
Total Car	2	25.00	2	25.00
Visitor's Car Parking	-	-	1	12.50
Total Visitor Parking	1	12.50	1	12.50
TwoWheeler	-	-	2	4.00
Total TwoWheeler	-	-	2	4.00
Other Parking	-	-	-	17.83
Total	-	37.50	-	63.33

Buildingwise Floor FAR Details

Floor Name	Building Name A (SMT SHILA SINHA)		Total	
	Proposed Built Up Area (Sq.mt.)	Proposed FAR Area (Sq.mt.)	Total Proposed Built Up Area (Sq.mt.)	Total FAR Area (Sq.mt.)
Parking Floor	71.56	16.23	71.56	16.23
First Floor	71.56	71.56	71.56	71.56
Second Floor	71.56	71.56	71.56	71.56
Terrace Floor	0.00	0.00	0.00	0.00
Total :	214.68	159.35	214.68	159.35

Building USE/SUBUSE Details

Building Name	Building Use	Building SubUse	Building Structure	Floor Name	Floor Use	Floor SubUse	FAR Name	FAR Use	FAR SubUse
A (SMT SHILA SINHA)	Residential	Bungalow/ Dwelling / Non Apartment	Non-Highrise	PARKING FLOOR PLAN	Residential	Bungalow/ Dwelling / Non Apartment	-	-	-
				TYPICAL - 1 & 2 FLOOR PLAN	Residential	Bungalow/ Dwelling / Non Apartment	Residential FAR	Residential	Bungalow/ Dwelling / Non Apartment
				TERRACE FLOOR PLAN	Residential	Bungalow/ Dwelling / Non Apartment	-	-	-

LTP NAME AND SIGNATURE	STRUCTURAL ENG'S NAME AND SIGNATURE	BUILDER NAME AND SIGNATURE	DIGITAL SIGNATURE
NABANITA BHATTACHERYA JNAC/DFTMN/0024/2017			