

Proposal Basic Information	
Proposal File No.	JNAC/BP/0076/W7/2024
Owner Name	SRI RAMESHWAR SINGH CHOUHAN
Khata No	HOLDING NO. 418
Plot No	HOLDING NO. 418
Village Name	SAKCHI
Use	Residential
SubUse	Bungalow/ Dwelling / Non Apartment

FAR & Tenement Details (Table 4c-1)

Building	No. of Same Bldg	Total Built Up Area (Sq.mt.)	Deductions (Area in Sq.mt.) Parking	Proposed FAR Area (Sq.mt.) Resi.	Add Area In FAR (Sq.mt.) Stair	Total FAR Area (Sq.mt.)	Total Consumed Additional FAR Area (Sq.mt.)	Tnmt (No.)
A (SRI RAMESHWAR SINGH CHOUHAN)	1	243.09	65.25	162.06	15.78	177.84	177.84	01
Grand Total :	1	243.09	65.25	162.06	15.78	177.84	177.84	01

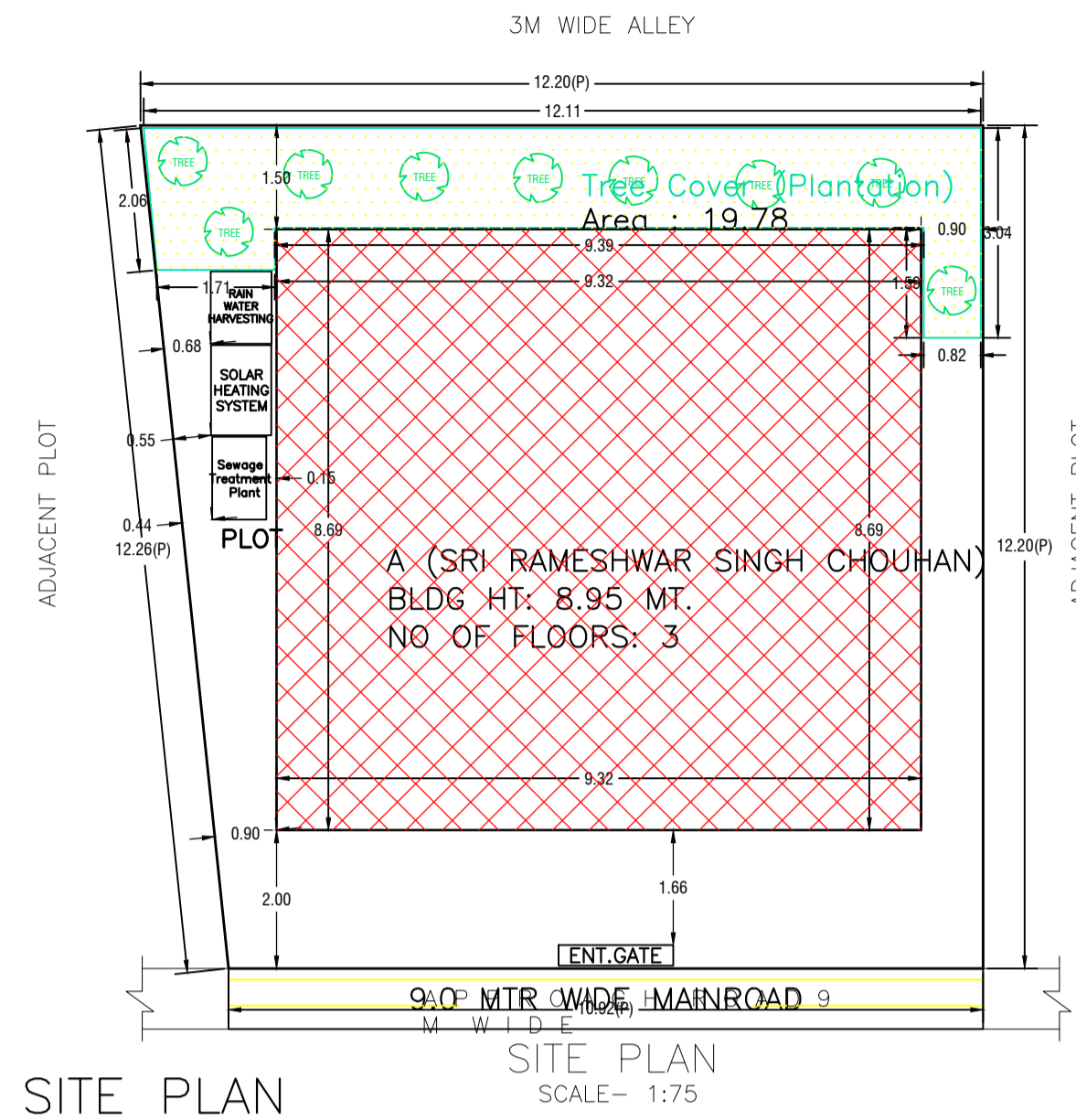

SITE PLAN

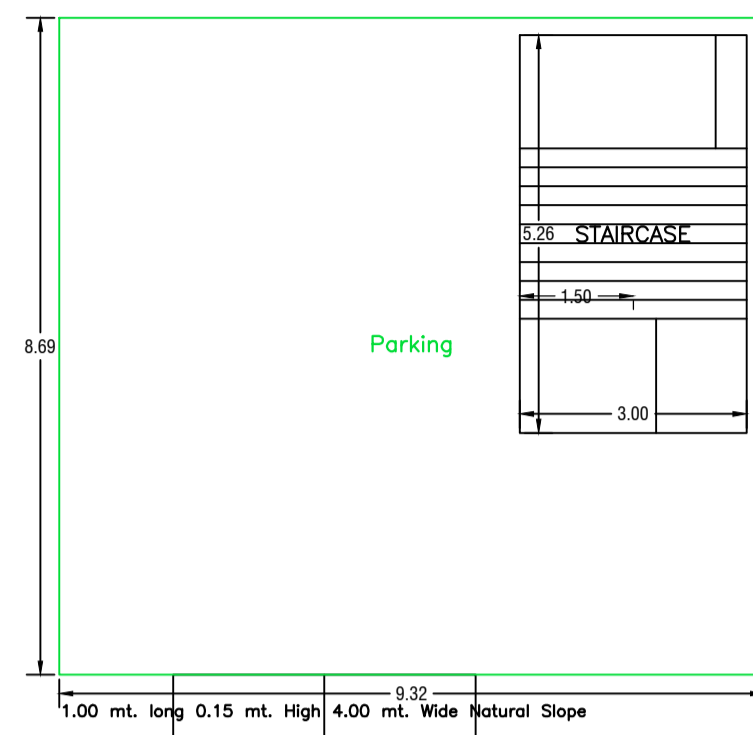

GROUND FLOOR PLAN (SCALE 1:100)

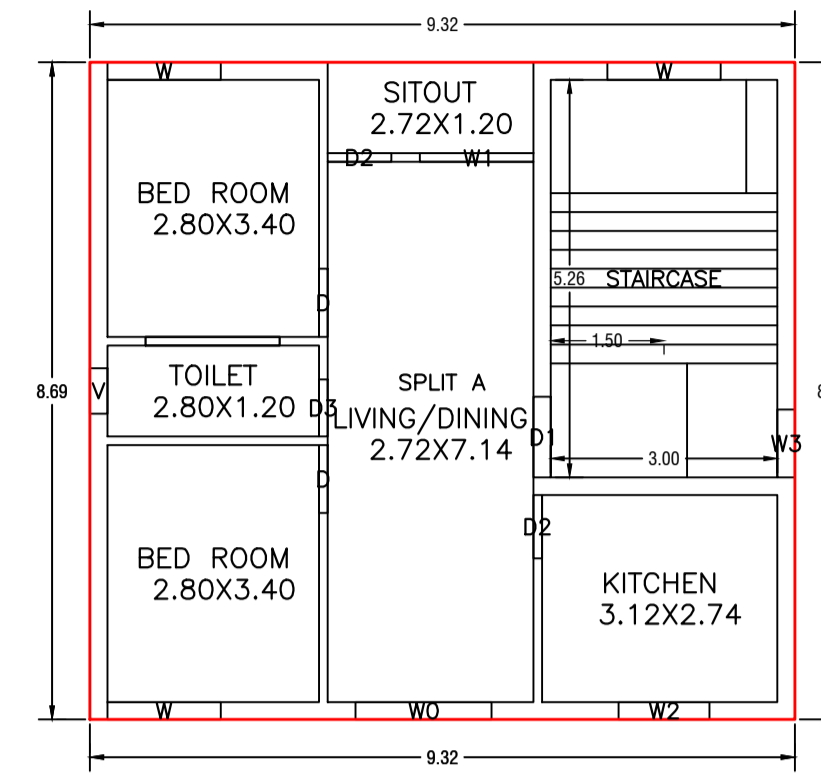

FIRST FLOOR PLAN (Proposed) (SCALE 1:100)

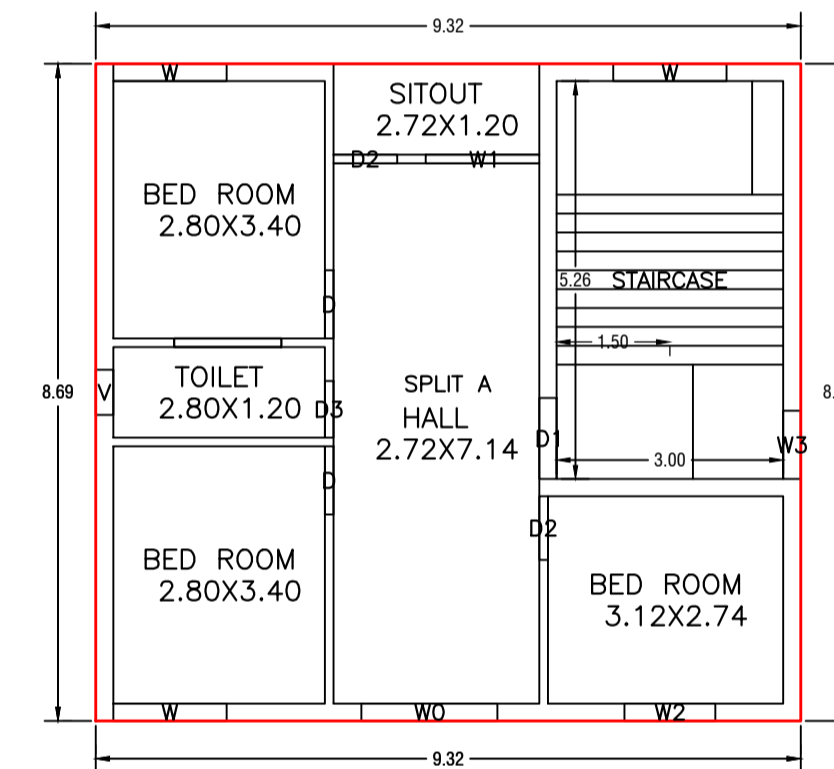

SECOND FLOOR PLAN (Proposed) (SCALE 1:100)

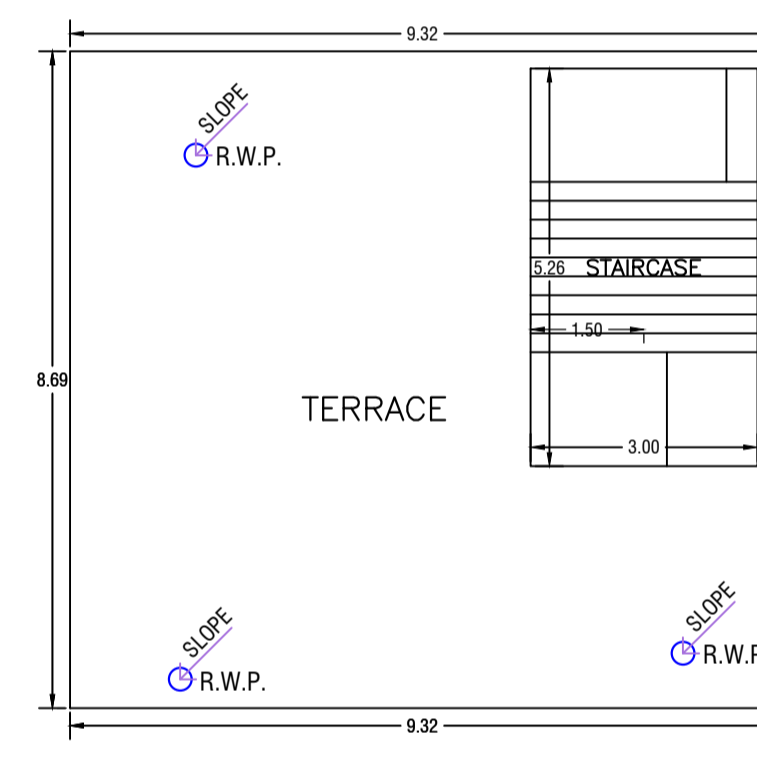

TERRACE FLOOR PLAN (SCALE 1:100)

Building :A (SRI RAMESHWAR SINGH CHOUHAN)

Floor Name	Total Built Up Area (Sq.mt.)	Deductions (Area in Sq.mt.) Parking	Proposed FAR Area (Sq.mt.) Resi.	Add Area In FAR (Sq.mt.) Stair	Total FAR Area (Sq.mt.)	Total Consumed Additional FAR Area (Sq.mt.)	Tnmt (No.)
Ground Floor	81.03	65.25	0.00	15.78	15.78	15.78	00
First Floor	81.03	0.00	81.03	0.00	81.03	81.03	01
Second Floor	81.03	0.00	81.03	0.00	81.03	81.03	00
Terrace Floor	0.00	0.00	0.00	0.00	0.00	0.00	00
Total :	243.09	65.25	162.06	15.78	177.84	177.84	01

SCHEDULE OF DOOR:

BUILDING NAME	NAME	LENGTH	HEIGHT	NOS
A (SRI RAMESHWAR SINGH CHOUHAN)	D3	0.75	2.13	02
A (SRI RAMESHWAR SINGH CHOUHAN)	D2	0.84	2.13	04
A (SRI RAMESHWAR SINGH CHOUHAN)	D	0.90	2.13	04
A (SRI RAMESHWAR SINGH CHOUHAN)	D1	1.07	2.13	02

SCHEDULE OF WINDOW/VENTILATION:

BUILDING NAME	NAME	LENGTH	HEIGHT	NOS
A (SRI RAMESHWAR SINGH CHOUHAN)	V	0.60	2.70	02
A (SRI RAMESHWAR SINGH CHOUHAN)	W3	0.90	2.70	02
A (SRI RAMESHWAR SINGH CHOUHAN)	W2	1.20	2.70	02
A (SRI RAMESHWAR SINGH CHOUHAN)	W	1.50	2.70	06
A (SRI RAMESHWAR SINGH CHOUHAN)	W1	1.50	2.70	02
A (SRI RAMESHWAR SINGH CHOUHAN)	W0	1.80	2.70	02

UnitBUA Table for Building :A (SRI RAMESHWAR SINGH CHOUHAN)

FLOOR	Name	UnitBUA Type	UnitBUA Area	Carpet Area	No. of Rooms	No. of Tenement
FIRST FLOOR PLAN	SPLIT A	FLAT	111.69	111.32	6	1
SECOND FLOOR PLAN	SPLIT A	FLAT	0.00	0.00	6	0
Total :	-	-	111.69	111.32	12	1

AREA STATEMENT JAMSHEDPUR NAC		VERSION NO.: 1.0.71
PROJECT DETAIL:		VERSION DATE: 16/10/2020
Region: JHARKHAND URBAN	Plot Use: Residential	
LOCAL BODIES	Plot SubUse: Bungalow/ Dwelling / Non Apartment	
District: EAST SINGHBHUM	PlotNearbyReligiousStructure: NA	
Authority: JAMSHEDPUR NAC	PlotSubPlot No: HOLDING NO. 418	
Inward No: JNAC/BP/0076/W7/2024	North: -	
Application Type: General Proposal	South: -	
Project Type: Building Permission	East: -	
Nature of Development: New	West: Road Width - 9.0 MTR WIDE MAIN ROAD	
Location of Development Area: Old Area		
AREA DETAILS:		
AREA OF PLOT (Minimum)	(A)	140.94
NET AREA OF PLOT (Gross Plot Area - Deduction from Gross Plot area)	(A-Deductions)	140.94
Deduction for Balance Plot Area (from Gross Plot Area)		
Common Plot		19.78
Total		19.78
BALANCE AREA OF PLOT (Net Plot Area - Recreational/Amenity space)	(A-Deductions)	121.16
PLOT AREA FOR COVERAGE (Net Plot Area)	(A-Deductions)	140.94
Plot Area for FAR (Net Plot Area + Road Widening Area)	(A-Deductions)	140.94
COVERAGE CHECK		
Permissible Coverage area (70.00 %)		98.66
Proposed Coverage Area (57.49 %)		81.03
Total Prop. Coverage Area (57.49 %)		81.03
Balance coverage area (12.51 %)		17.63
FAR CHECK		
Perm. FAR Area (2.500)		352.35
Total Perm. FAR area		352.35
Residential FAR area		162.05
Proposed FAR Area		177.84
Total Proposed FAR Area		177.84
Consumed FAR (Factor)		1.26
Balance FAR Area		174.51
BUILT UP AREA CHECK		
Total Proposed BuiltUp Area		243.09
ARCHITECT (Regd)	Amarjeet Balmuchu	
ENGINEER (Regd)		
SUPERVISOR (Regd)		
OWNER (Regd)	SRI RAMESHWAR SINGH CHOUHAN	
DEVELOPMENT AUTHORITY LOCAL BODY		

COLOR INDEX	
PLOT BOUNDARY	Black
ABUTTING ROAD	Green
PROPOSED CONSTRUCTION	Red
COMMON PLOT	Yellow
ROAD WIDENING AREA	Blue
EXISTING (To be retained)	Orange
EXISTING (To be demolished)	Light Blue

Buildingwise Floor FAR Details

Floor Name	Building Name A (SRI RAMESHWAR SINGH CHOUHAN)		Total	
	Proposed Built Up Area (Sq.mt.)	Proposed FAR Area (Sq.mt.)	Total Proposed Built Up Area (Sq.mt.)	Total FAR Area (Sq.mt.)
Ground Floor	81.03	15.78	81.03	15.78
First Floor	81.03	81.03	81.03	81.03
Second Floor	81.03	81.03	81.03	81.03
Terrace Floor	0.00	0.00	0.00	0.00
Total :	243.09	177.84	243.09	177.84

Building USE/SUBUSE Details

Building Name	Building Use	Building SubUse	Building Structure	Floor Name	Floor Use	Floor SubUse	FAR Name	FAR Use	FAR SubUse
A (SRI RAMESHWAR SINGH CHOUHAN)	Residential	Bungalow/ Dwelling / Non Apartment	Non-Highrise	GROUND FLOOR PLAN	Residential	Bungalow/ Dwelling / Non Apartment	-	-	-
				FIRST FLOOR PLAN	Residential	Bungalow/ Dwelling / Non Apartment	Residential FAR	Residential	Bungalow/ Dwelling / Non Apartment
				SECOND FLOOR PLAN	Residential	Bungalow/ Dwelling / Non Apartment	Residential FAR	Residential	Bungalow/ Dwelling / Non Apartment
				TERRACE FLOOR PLAN	Residential	Bungalow/ Dwelling / Non Apartment	-	-	-

LTP NAME AND SIGNATURE	STRUCTURAL ENG'S NAME AND SIGNATURE	BUILDER NAME AND SIGNATURE	DIGITAL SIGNATURE
Amarjeet Balmuchu JNAC/ARC/0008/2018			

Proposal Basic Information

Proposal File No.	JNAC/BP/0076/W7/2024
Owner Name	SRI RAMESHWAR SINGH CHOUHAN
Khata No	HOLDING NO. 418
Plot No	HOLDING NO. 418
Village Name	SAKCHI
Use	Residential
SubUse	Bungalow Dwelling / Non Apartment

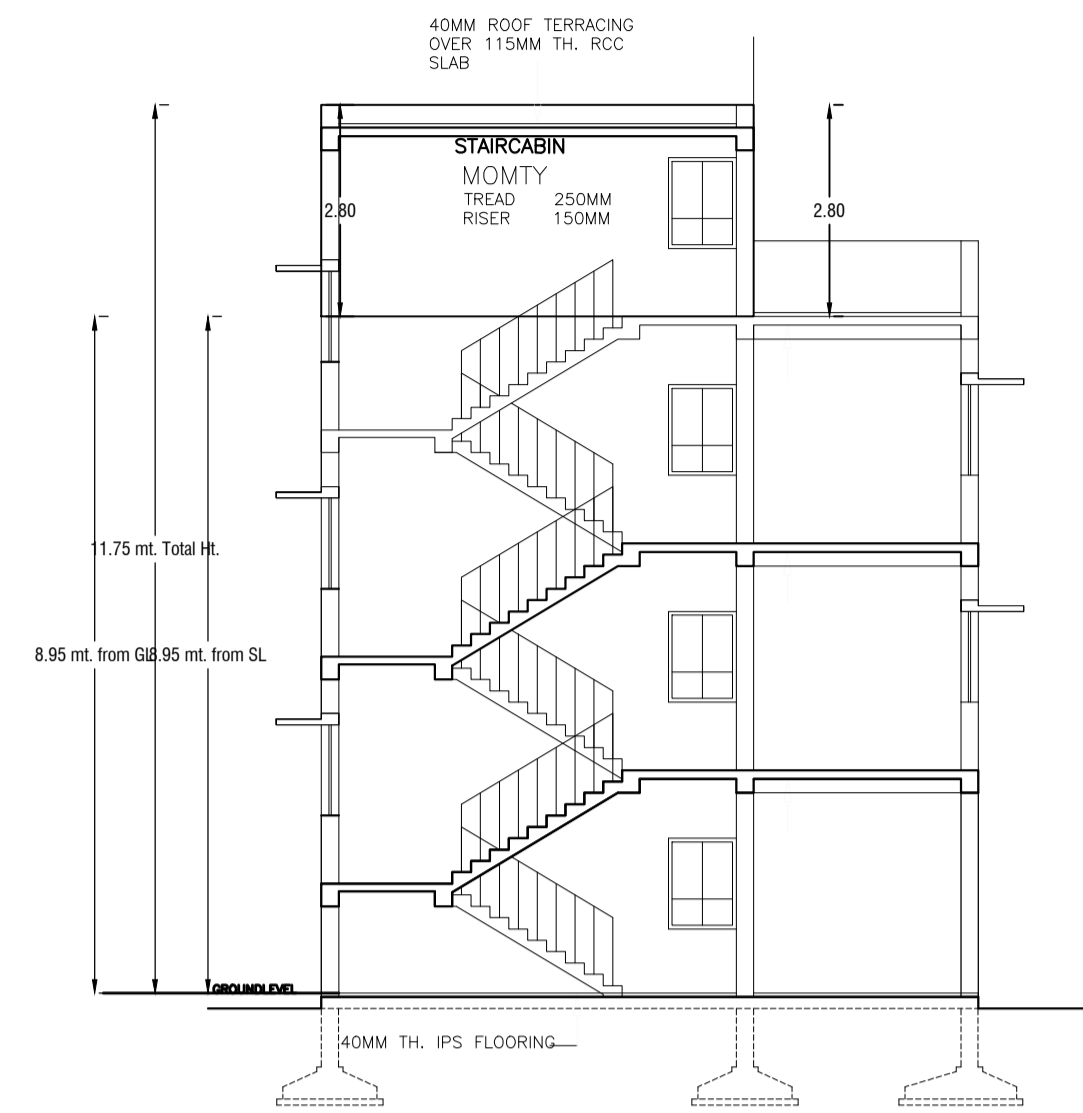

SECTION BB
SCALE- 1:75

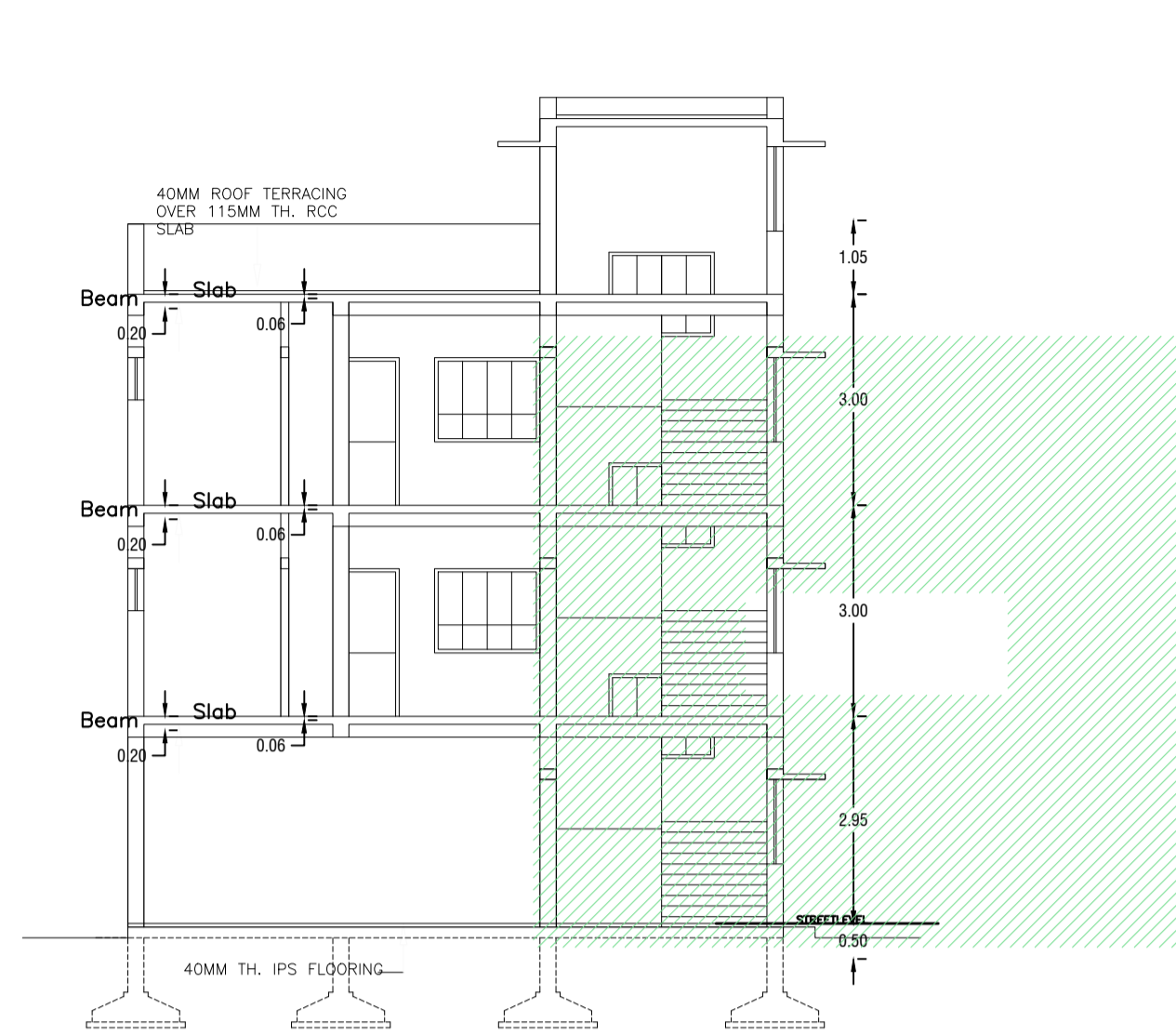

SECTION AA
SCALE- 1:75

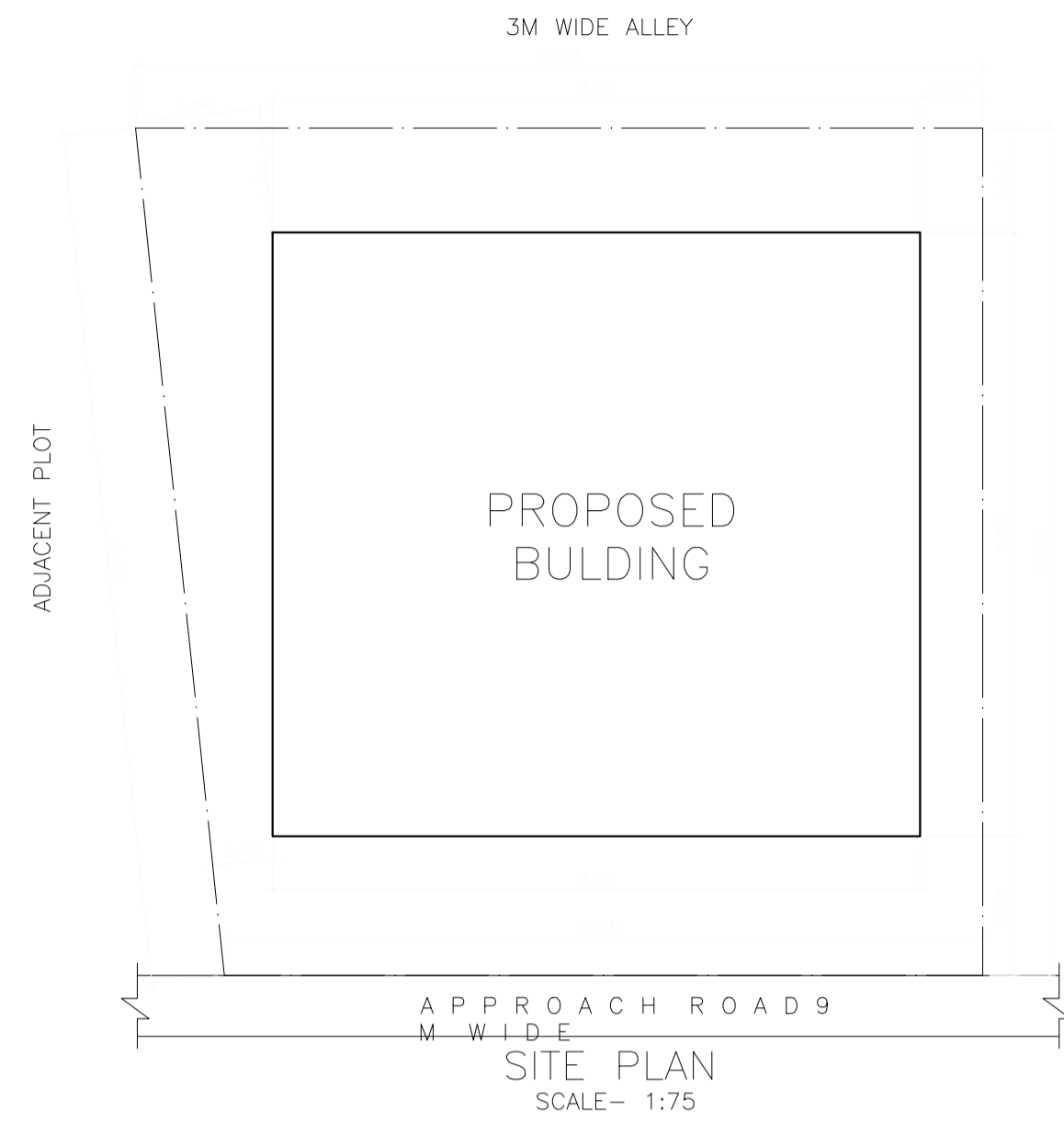

SITE PLAN
SCALE- 1:75

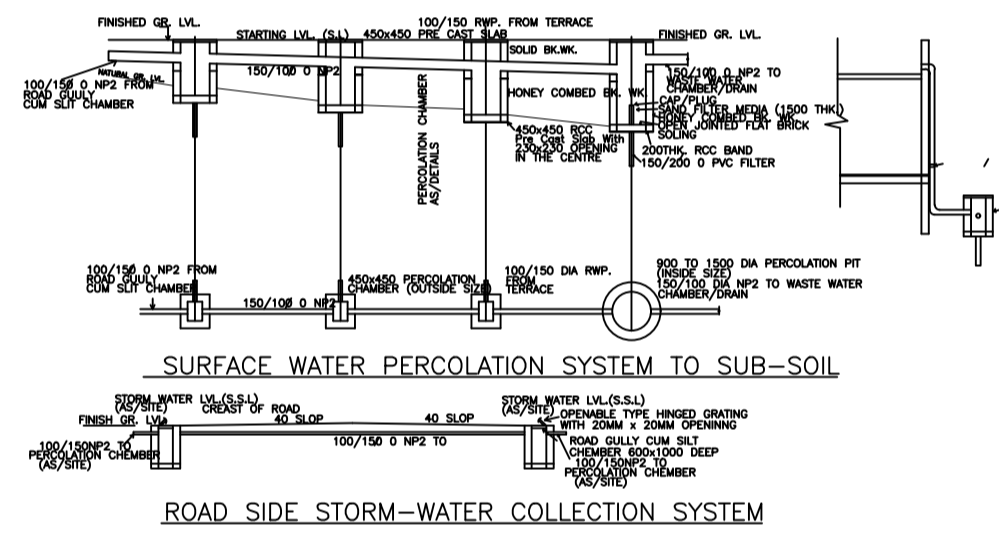

SURFACE WATER PERCOLATION SYSTEM TO SUB-SOIL
ROAD SIDE STORM-WATER COLLECTION SYSTEM

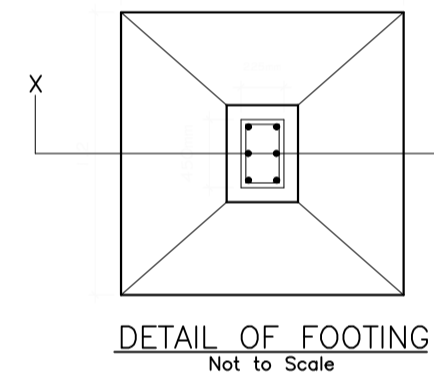

DETAIL OF FOOTING
Not to Scale

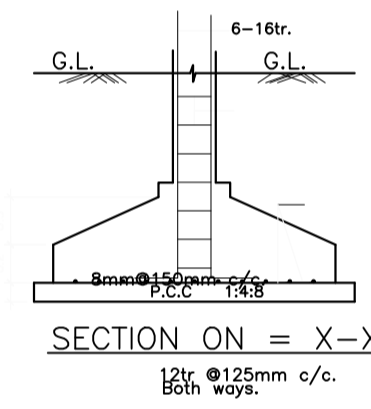

SECTION ON = X-X
120. Ø125mm c/c. Both ways.

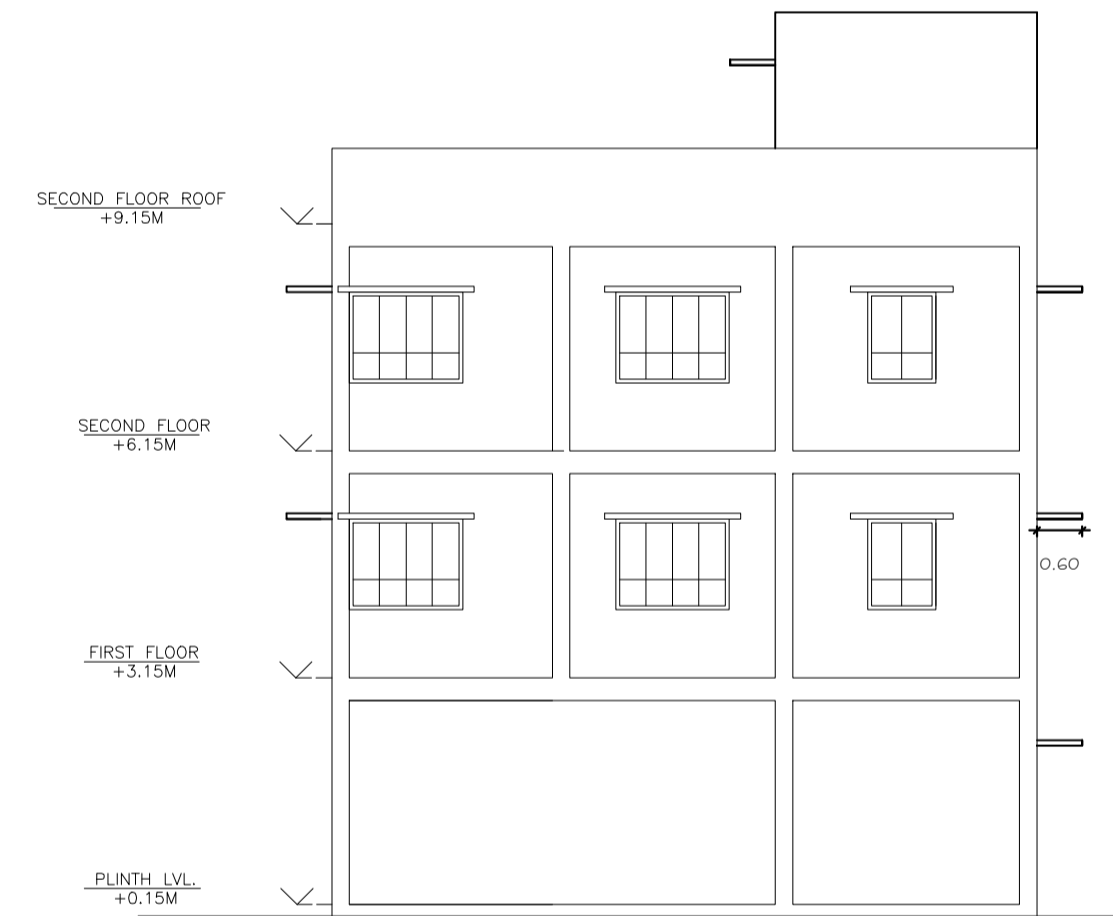

FRONT ELEVATION
SCALE- 1:75

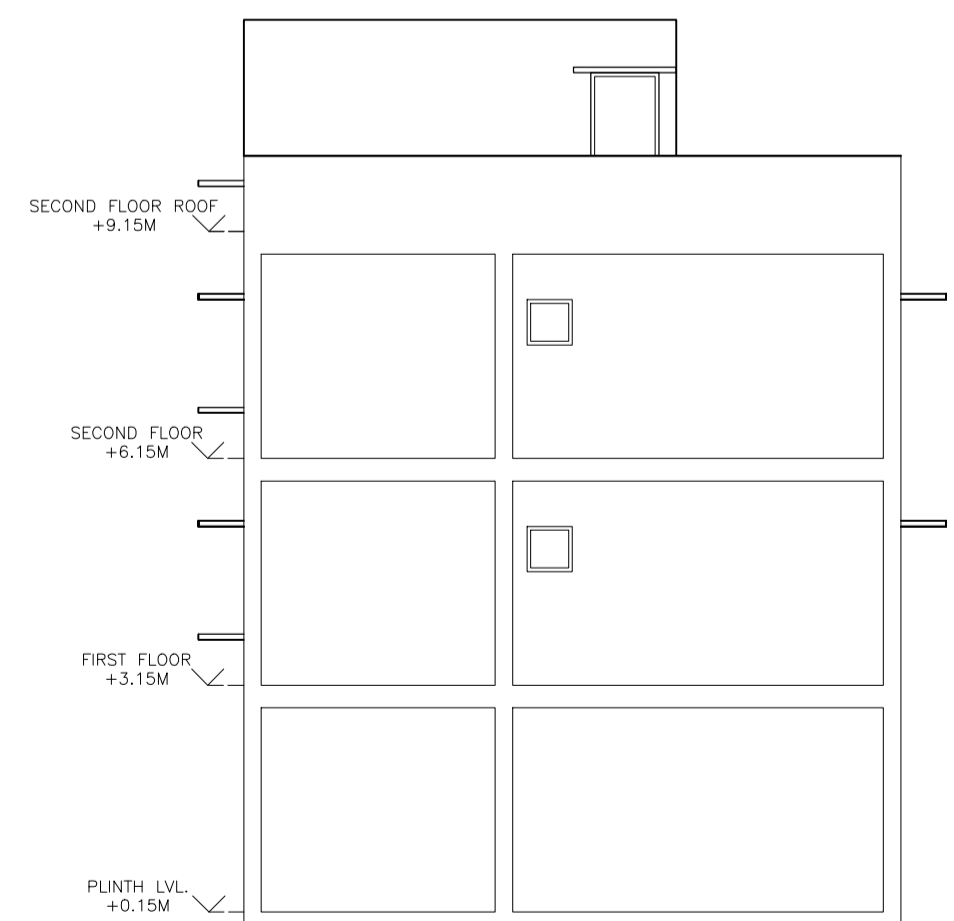

SIDE ELEVATION
SCALE- 1:75

LTP NAME AND SIGNATURE	STRUCTURAL ENG'S NAME AND SIGNATURE	BUILDER NAME AND SIGNATURE	DIGITAL SIGNATURE
Amarjeet Balmuchu JNAC/ARC/0008/2018			