

FAR & Tenement Details (Table 4c-1)

Building	No. of Same Bldg	Total Built Up Area (Sq.mt.)	Deductions (Area in Sq.mt.)		Proposed FAR Area (Sq.mt.)	Add Area in FAR (Sq.mt.)	Total FAR Area (Sq.mt.)	Total Consumed Additional FAR Area (Sq.mt.)	Trmt (No.)
			Parking	Resi.					
A (PREMBATI)	1	135.39	33.78	90.26	90.26	11.35	101.61	101.61	01
Grand Total:	1	135.39	33.78	90.26	90.26	11.35	101.61	101.61	01

Proposal Basic Information

Proposal File No.	JNAC/BP/0079/W11/2024
Owner Name	PREMBATI
Khata No	52
Plot No	331
Village Name	Sitaramdera
Use	Residential
SubUse	Row House

Building :A (PREMBATI)

Floor Name	Total Built Up Area (Sq.mt.)	Deductions (Area in Sq.mt.)		Proposed FAR Area (Sq.mt.)	Add Area in FAR (Sq.mt.)	Total FAR Area (Sq.mt.)	Total Consumed Additional FAR Area (Sq.mt.)	Trmt (No.)
		Parking	Resi.					
Parking Floor	45.13	33.78	0.00	11.35	11.35	11.35	0.00	
First Floor	45.13	0.00	45.13	0.00	45.13	45.13	0.00	
Second Floor	45.13	0.00	45.13	0.00	45.13	45.13	0.00	
Terrace Floor	0.00	0.00	0.00	0.00	0.00	0.00	0.00	
Total:	135.39	33.78	90.26	11.35	101.61	101.61	01	

SCHEDULE OF DOOR:

BUILDING NAME	NAME	LENGTH	HEIGHT	NOS
A (PREMBATI)	D3	0.80	2.10	04
A (PREMBATI)	D2	0.90	2.10	01
A (PREMBATI)	D1	1.20	2.10	02

SCHEDULE OF WINDOW/VENTILATION:

BUILDING NAME	NAME	LENGTH	HEIGHT	NOS
A (PREMBATI)	V	0.60	0.60	02
A (PREMBATI)	W4	0.90	1.20	01
A (PREMBATI)	W3	1.20	1.20	04
A (PREMBATI)	W2	1.50	1.20	01
A (PREMBATI)	W1	1.80	1.20	01
A (PREMBATI)	W1	2.40	1.20	01

UnitBUA Table for Building :A (PREMBATI)

FLOOR	Name	UnitBUA Type	UnitBUA Area	Carpet Area	No. of Rooms	No. of Tenement
FIRST FLOOR PLAN	SPLIT A	FLAT	90.25	80.95	4	1
SECOND FLOOR PLAN	SPLIT A	FLAT	0.00	0.00	3	0
Total:	-	-	90.25	80.95	7	1

AREA STATEMENT

AREA STATEMENT	VERSION NO.:	VERSION DATE:	SQ.MT.
JAMSHEDPUR NAC	1.0.71	16/10/2020	
PROJECT DETAIL:			
Region: JHARKHAND URBAN LOCAL BODIES	Plot Use: Residential		
District: EAST SINGBHUM	Plot SubUse: Row House		
Authority: JAMSHEDPUR NAC	Plot/Nearby/Religious/Structure: NA		
Inward No: JNAC/BP/0079/W11/2024	Plot/SubPlot No: 331		
Application Type: General Proposal	North: Plot No. - 332		
Project Type: Building Permission	South: Plot No. - 330		
Nature of Development: New	East: Road Width - 6.25		
Location of Development Area: Old Area	West: Road Width - 4.5		
AREA DETAILS:			
AREA OF PLOT (Minimum)	(A)		74.27
NET AREA OF PLOT (Gross Plot Area - Deduction from Gross Plot area)	(A-Deductions)		74.27
Deduction for Balance Plot Area (from Gross Plot Area)			
Common Plot			7.15
Total			7.15
BALANCE AREA OF PLOT (Net Plot Area - Recreational/Amenity space)	(A-Deductions)		67.12
PLOT AREA FOR COVERAGE (Net Plot Area)	(A-Deductions)		74.27
Plot Area for FAR (Net Plot Area + Road Widening Area)	(A-Deductions)		74.27
COVERAGE CHECK			
Permissible Coverage area (70.00 %)			51.99
Proposed Coverage Area (60.77 %)			45.13
Total Prop. Coverage Area (60.77 %)			45.13
Balance coverage area (9.24 %)			6.86
FAR CHECK			
Perm. FAR Area (2.500)			185.67
Total Perm. FAR area			185.67
Residential FAR			90.25
Proposed FAR Area			101.61
Total Proposed FAR Area			101.61
Consumed FAR (Factor)			1.37
Balance FAR Area			84.06
BUILT UP AREA CHECK			
Total Proposed BuiltUp Area			135.39
ARCHITECT (Regd)			SHREYASHI PAUL
ENGINEER (Regd)			
SUPERVISOR (Regd)			
OWNER (Regd)			PREMBATI
DEVELOPMENT AUTHORITY			LOCAL BODY

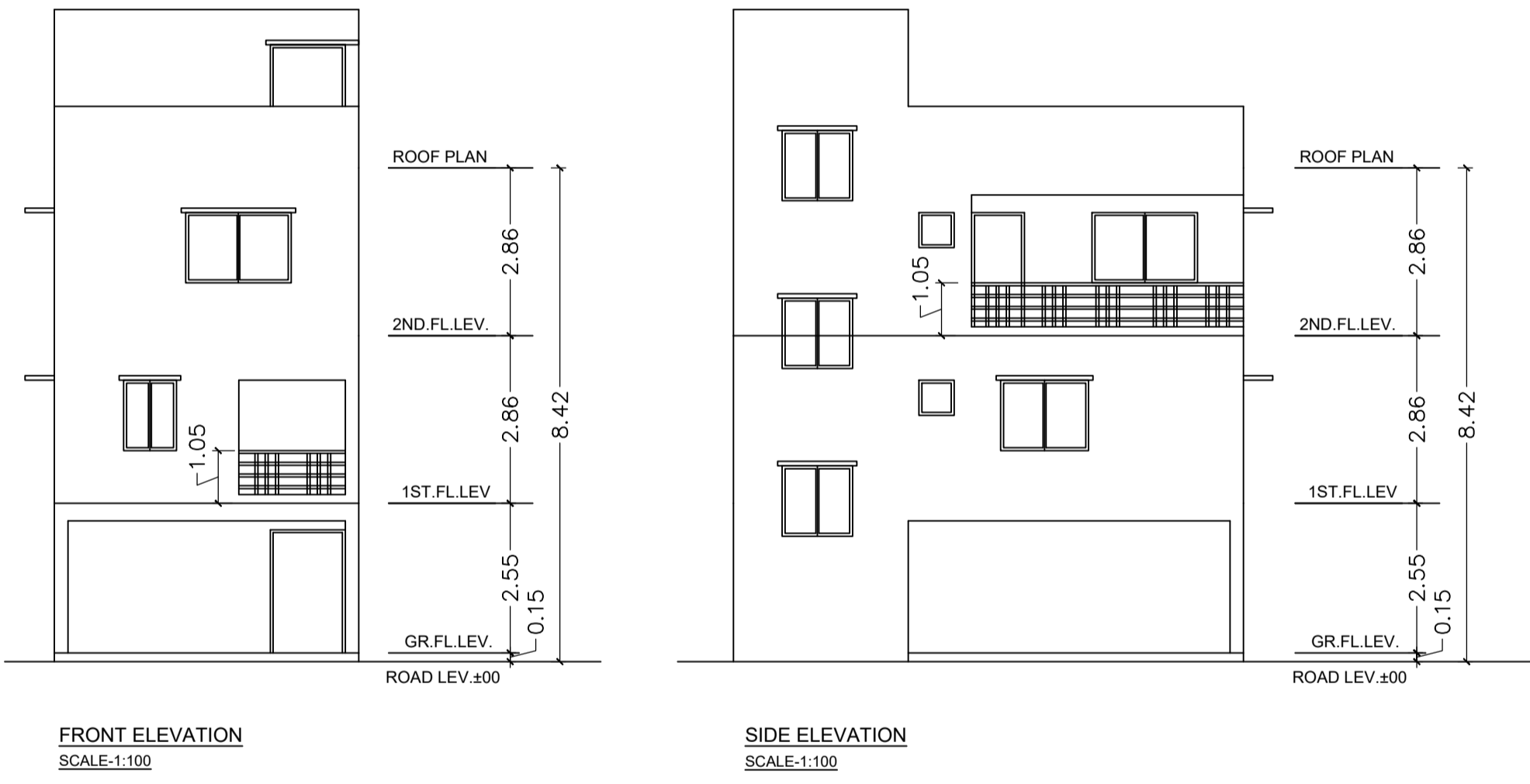
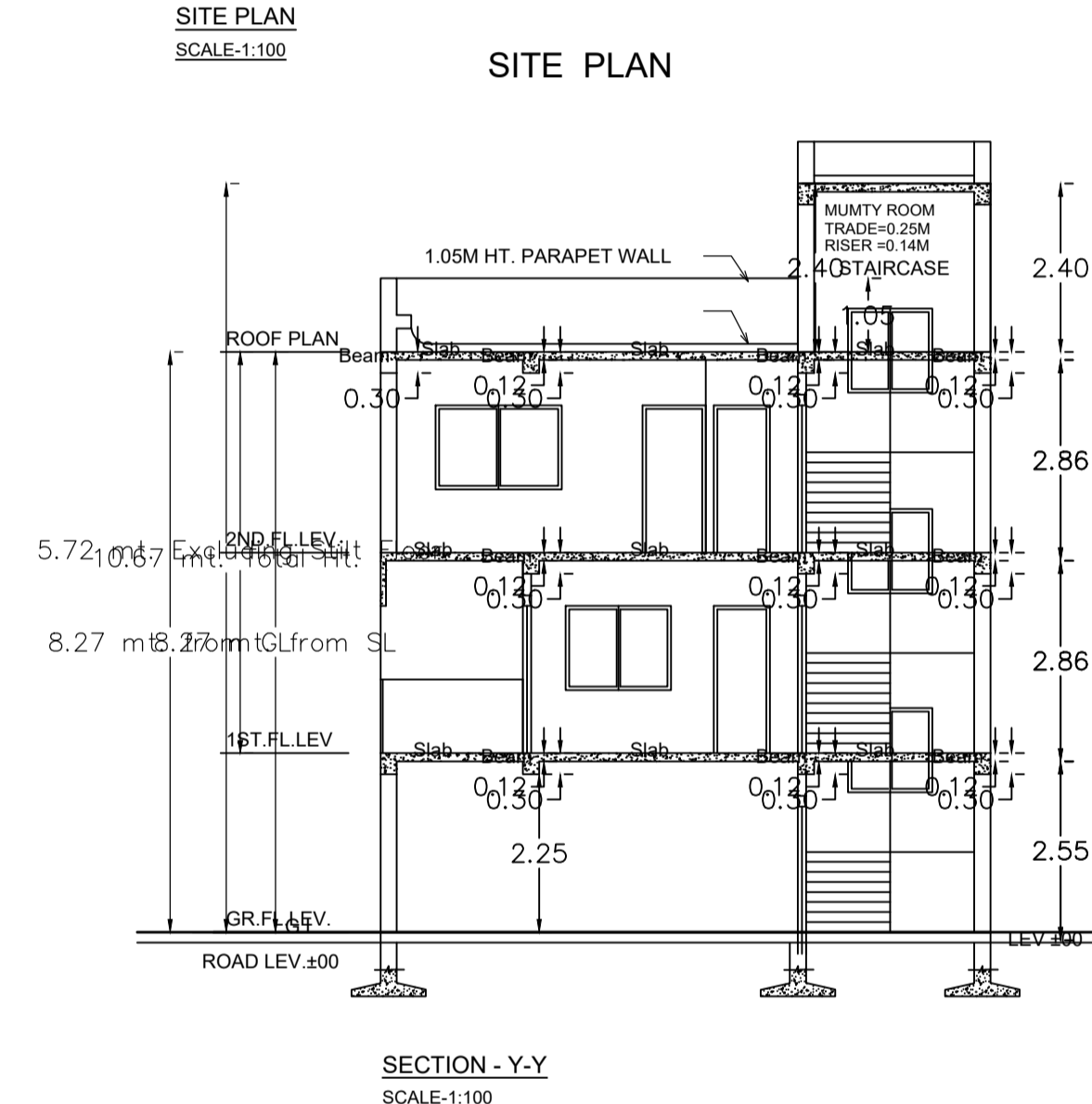

COLOR INDEX

PLOT BOUNDARY	Black
ABUTTING ROAD	Green
PROPOSED CONSTRUCTION	Red
COMMON PLOT	Yellow
ROAD WIDENING AREA	Blue
EXISTING (To be retained)	Light Blue
EXISTING (To be demolished)	Dark Blue

Buildingwise Floor FAR Details

Floor Name	Building Name A (PREMBATI)		Total	
	Proposed Built Up Area (Sq.mt.)	Proposed FAR Area (Sq.mt.)	Total Proposed Built Up Area (Sq.mt.)	Total FAR Area (Sq.mt.)
Parking Floor	45.13	11.35	45.13	11.35
First Floor	45.13	45.13	45.13	45.13
Second Floor	45.13	45.13	45.13	45.13
Terrace Floor	0.00	0.00	0.00	0.00
Total :	135.39	101.61	135.39	101.61

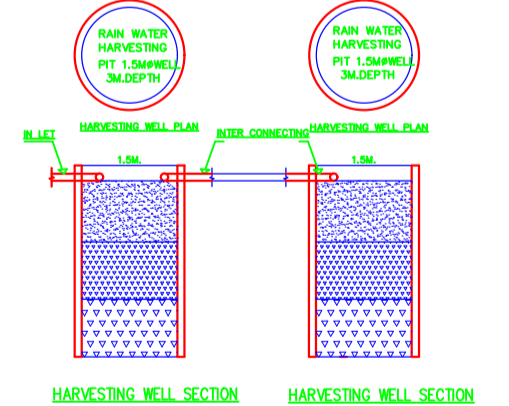
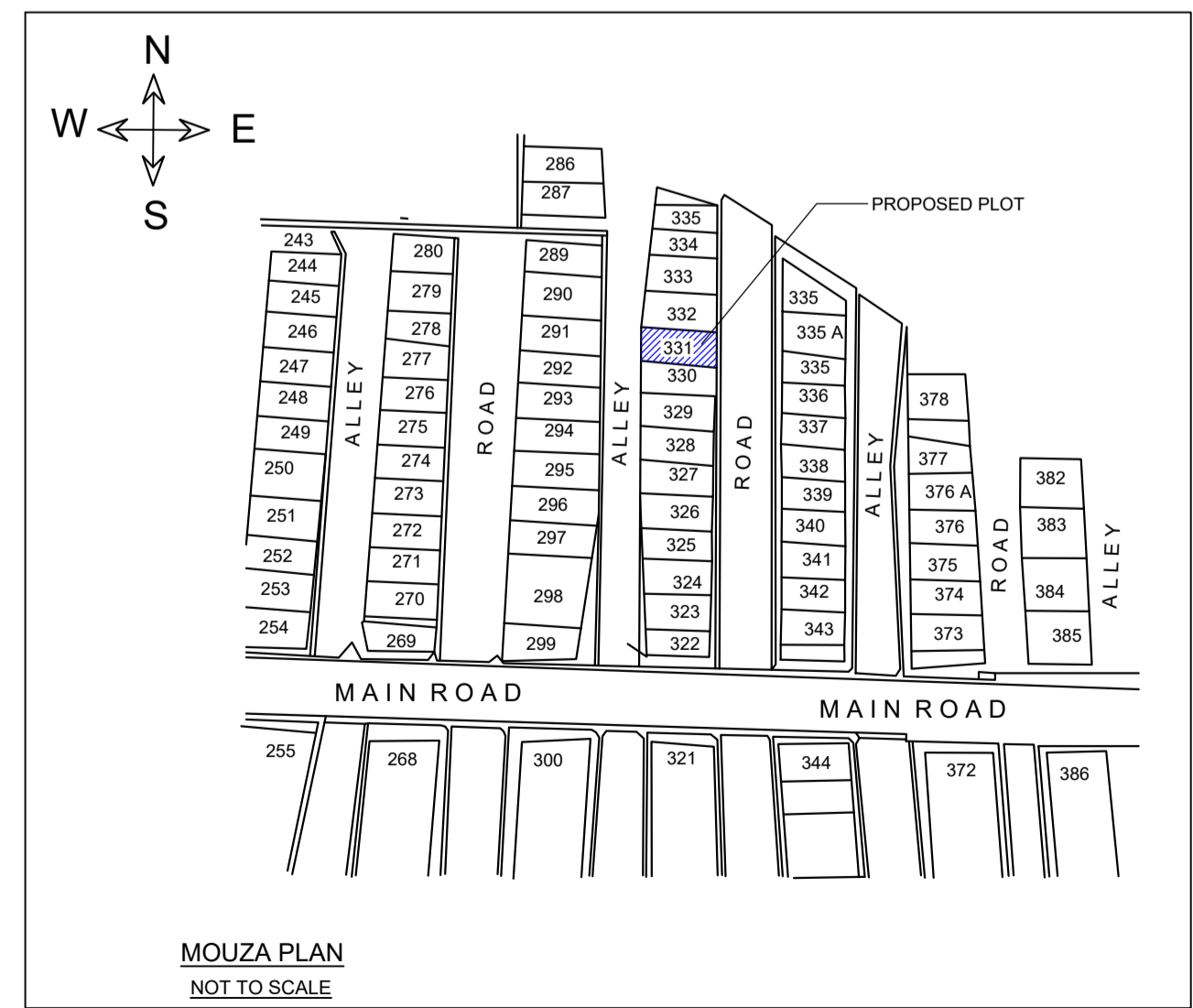
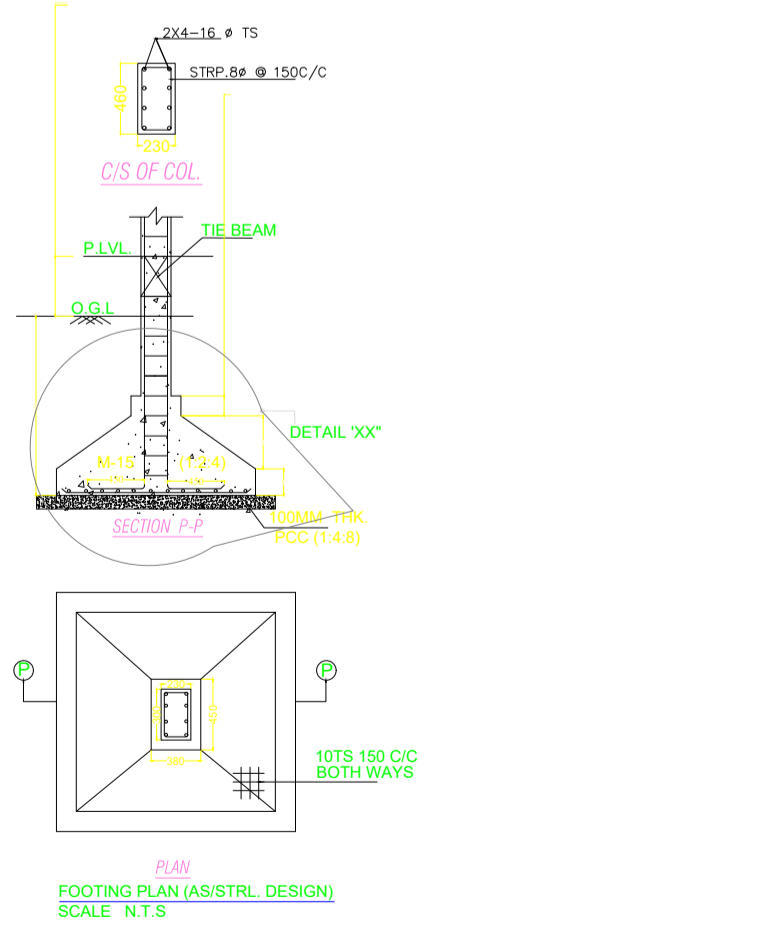
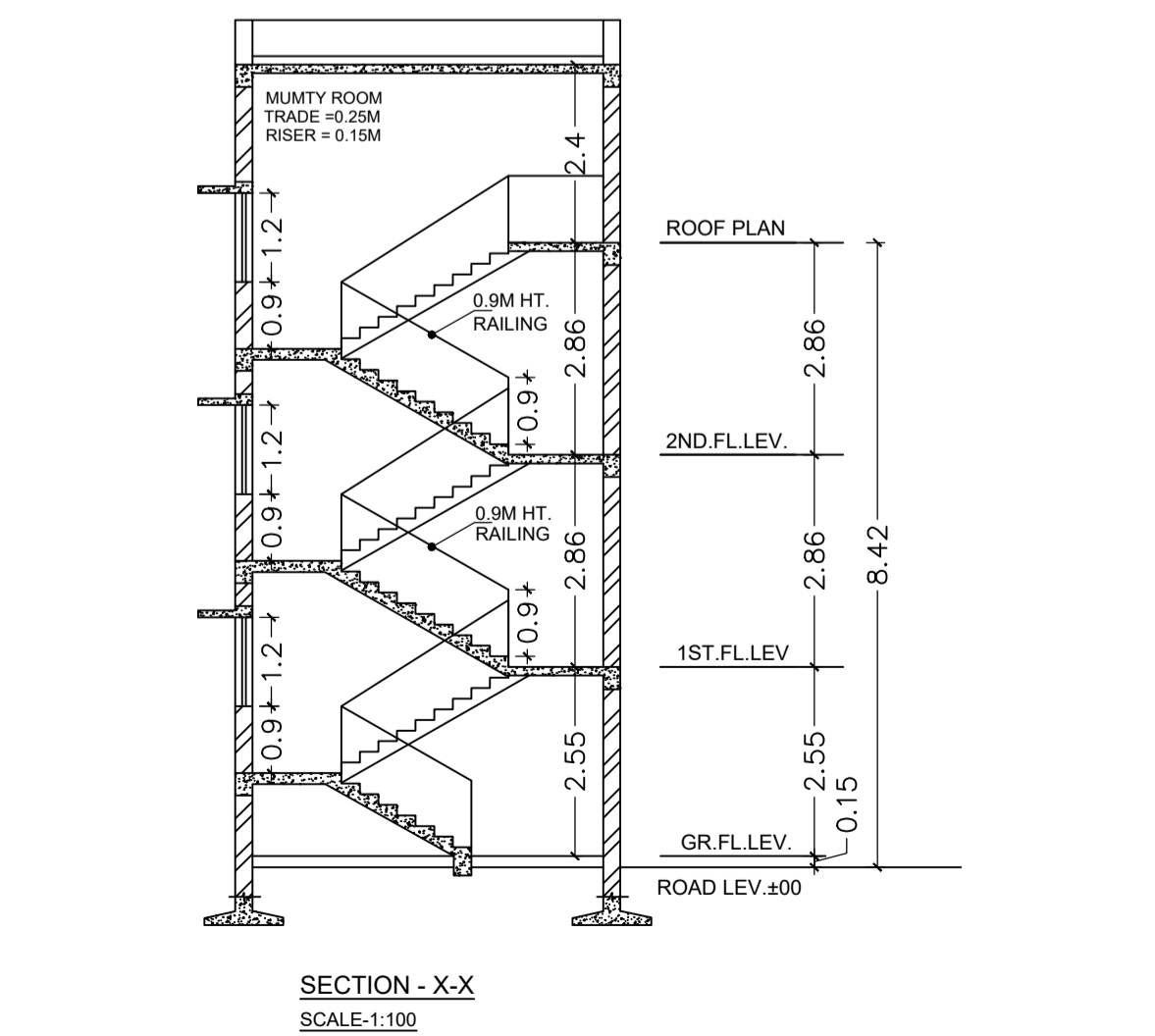

Building USE/SUBUSE Details

Building Name	Building Use	Building SubUse	Building Structure	Floor Name			Floor Use			Floor SubUse		
				Floor Name	Floor Use	Floor SubUse	FAR Name	FAR Use	FAR SubUse			
A (PREMBATI)	Residential	Row House	Non-Highrise	PARKING FLOOR PLAN	Residential	Row House	-	-	-	-	-	-
				FIRST FLOOR PLAN	Residential	Row House	Residential FAR	Residential	Row House			
				SECOND FLOOR PLAN	Residential	Row House	Residential FAR	Residential	Row House			
				TERRACE FLOOR PLAN	Residential	Row House	-	-	-			

LTP NAME AND SIGNATURE	STRUCTURAL ENG'S NAME AND SIGNATURE	BUILDER NAME AND SIGNATURE	DIGITAL SIGNATURE
SHREYASHI PAUL JNAC/DFTMN/0009/2016			