

Building :A (MRS MD AFTAB AHMAD)

Floor Name	Total Built Up Area (Sq.mt.)	Deductions (Area in Sq.mt.)	Proposed FAR Area (Sq.mt.)	Add Area In FAR (Sq.mt.)	Total FAR Area (Sq.mt.)	Total Consumed Additional FAR Area (Sq.mt.)	Tnmt (No.)
First Floor	63.65	54.83	0.00	0.00	8.82	8.82	00
Second Floor	0.00	0.00	63.65	0.00	63.65	63.65	01
Terrace Floor	0.00	0.00	0.00	0.00	0.00	0.00	00
<b>Total :</b>	<b>190.95</b>	<b>54.83</b>	<b>127.30</b>	<b>8.82</b>	<b>136.12</b>	<b>136.12</b>	<b>01</b>
Total Number of Same Buildings :	1						
<b>Total :</b>	<b>190.95</b>	<b>54.83</b>	<b>127.30</b>	<b>8.82</b>	<b>136.12</b>	<b>136.12</b>	<b>01</b>

AREA STATEMENT MANGO		VERSION NO. : 1.0.24
MAC		VERSION DATE: 30/03/2018
PROJECT DETAIL:		
Region: JHARKHAND URBAN LOCAL BODIES		Plot Use: Residential
District: EAST SINGHBHUM		Plot SubUse: Bungalow/ Dwelling / Non Apartment
Authority: MANGO NAC		Plot/Nearby/Religious/Structure: NA
Inward No: MNAC/BI/0012/W09/2018		Plot/SubPlot No: 504
Application Type: General Proposal		North: Survey No. - Nij
Project Type: Building Permission		South: Survey No. - Shamina Bano
Nature of Development: New		East: Road Width - 4.85
Location of Development Area: Old Area		West: Plot No. - 503
AREA DETAILS:		
AREA OF PLOT (Minimum)	(A)	SQ.MT. 99.76
Deduction for NetPlot Area		
Extra Land Area		1.13
Total		1.13
NET AREA OF PLOT(Gross Plot Area - Deduction from Gross Plot area)	(A-Deductions)	98.63
Deduction for Balance Plot Area(from Gross Plot Area)		
Extra Land Area		1.13
Common Plot		19.93
Total		21.06
BALANCE AREA OF PLOT(Net Plot Area - Recreational/Amenity space)	(A-Deductions)	78.70
PLOT AREA FOR COVERAGE(Net Plot Area)	(A-Deductions)	98.63
Plot Area for FAR (Net Plot Area + Road/Widening Area)	(A-Deductions)	98.63
COVERAGE CHECK		
Permissible Coverage area ( 70.00 % )		69.04
Proposed Coverage Area ( 64.53 % )		63.65
Total Prop. Coverage Area ( 64.53 % )		63.65
Balance coverage area ( 5.46 % )		5.39
FAR CHECK		
Perm. FAR Area ( 2.50 )		246.58
Total Perm. FAR area		127.29
Proposed FAR Area		136.11
Total Proposed FAR Area		136.11
Consumed FAR (Factor)		1.38
Balance FAR Area		110.47
BUILT UP AREA CHECK		
Total Proposed BuiltUp Area		190.95
ARCHITECT (Regd)	L K Suman	
ENGINEER (Regd)		
SUPERVISOR (Regd)		
OWNER (Regd)	Md. Aftab Ahmad	
DEVELOPMENT AUTHORITY		LOCAL BODY

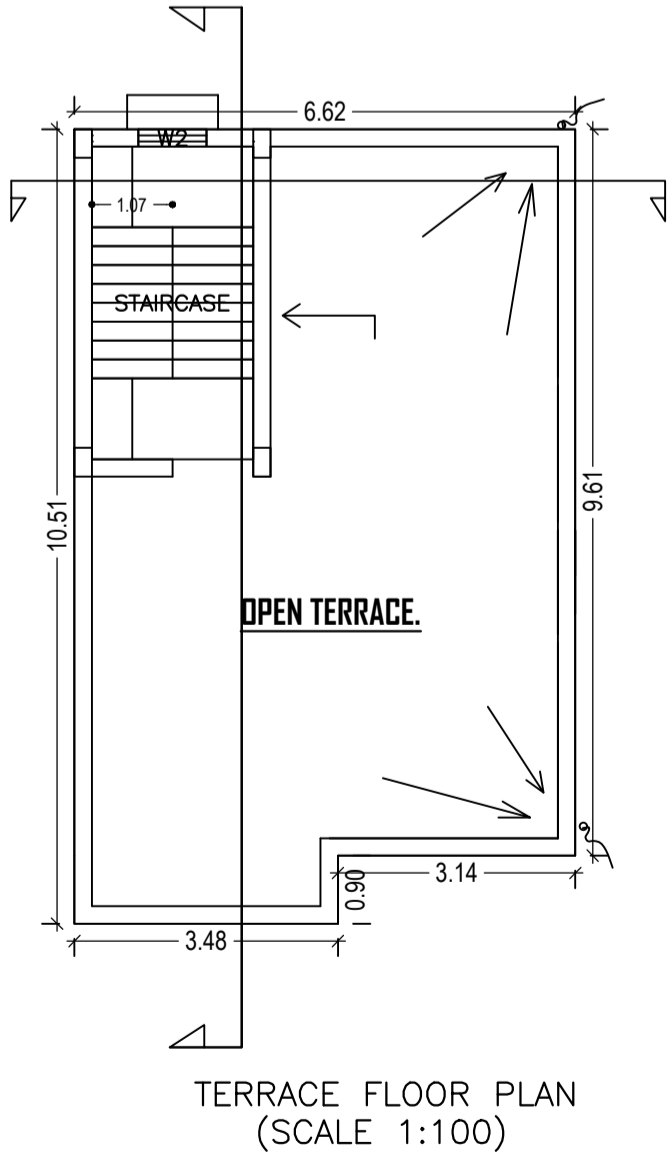
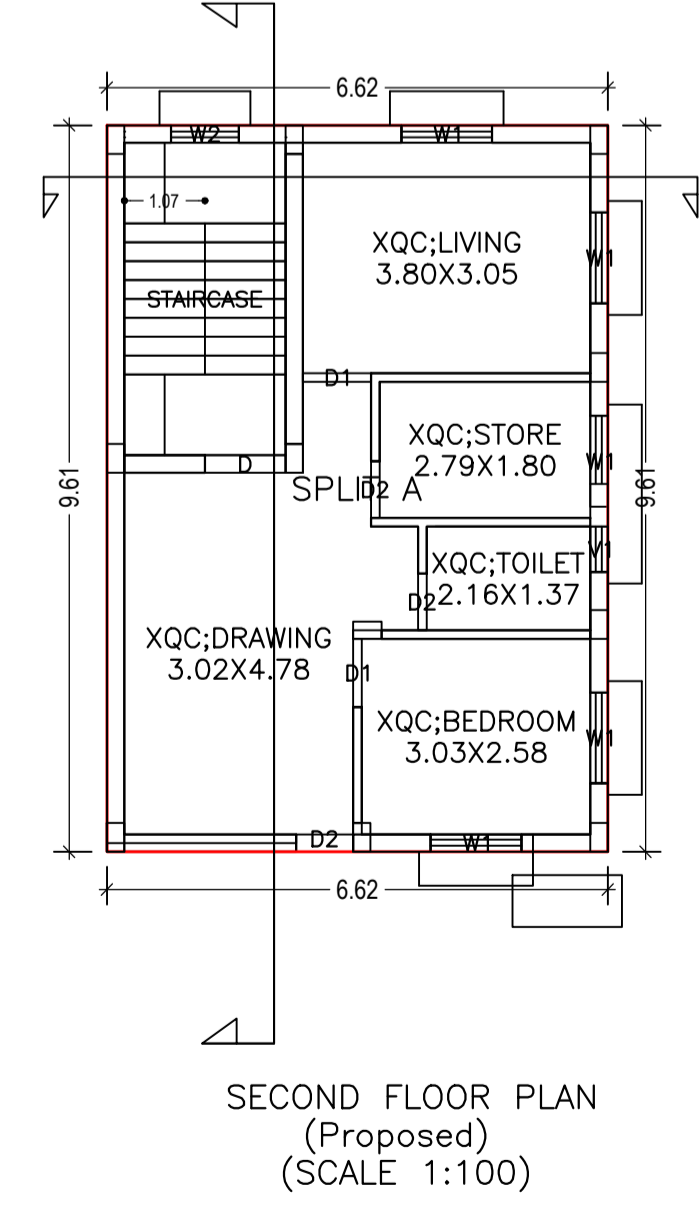
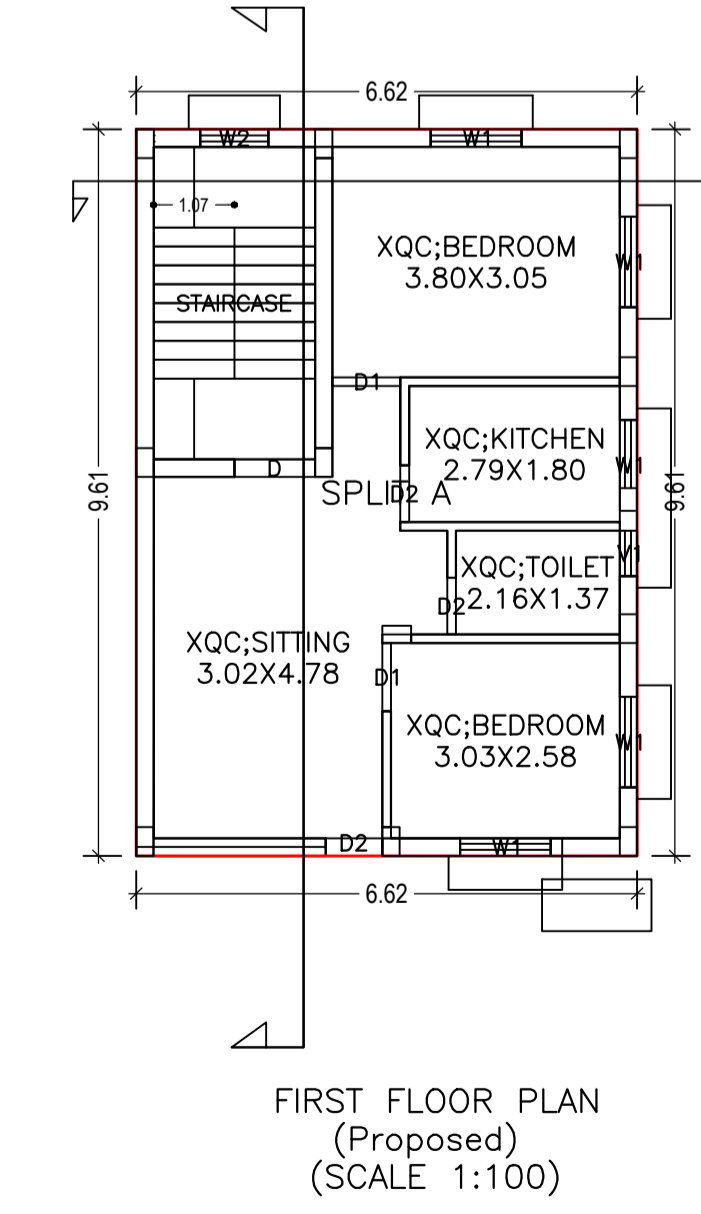
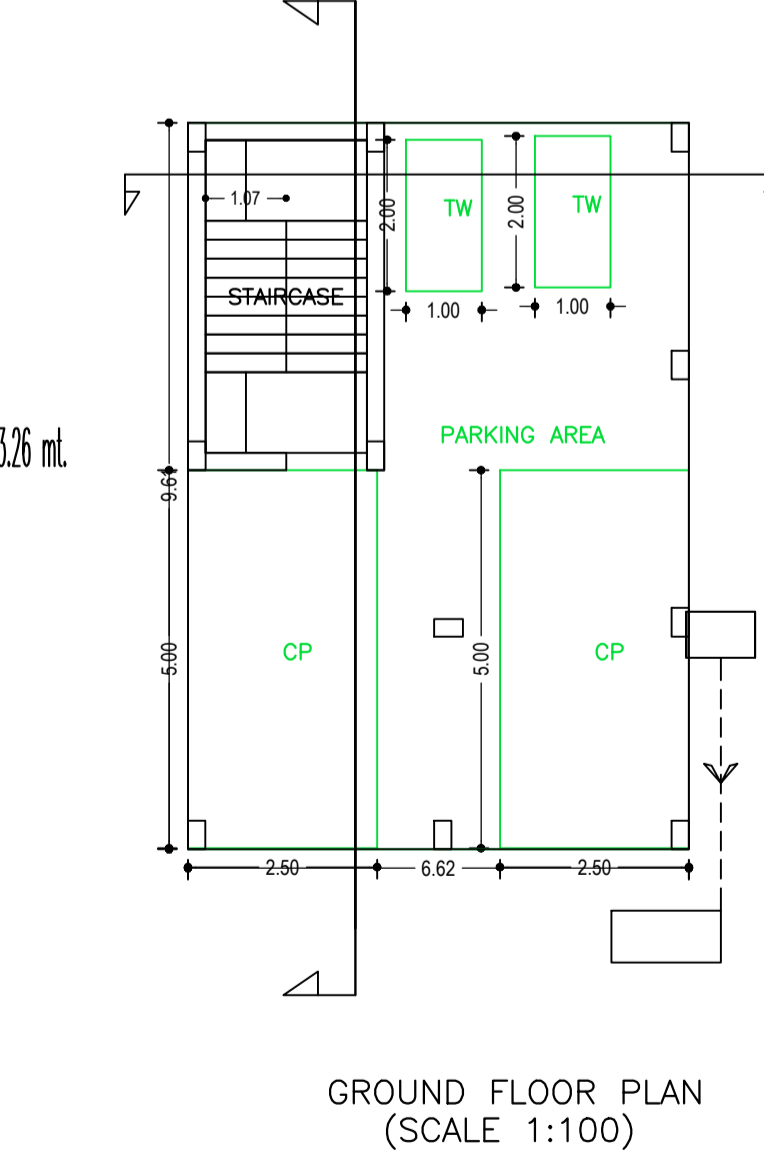
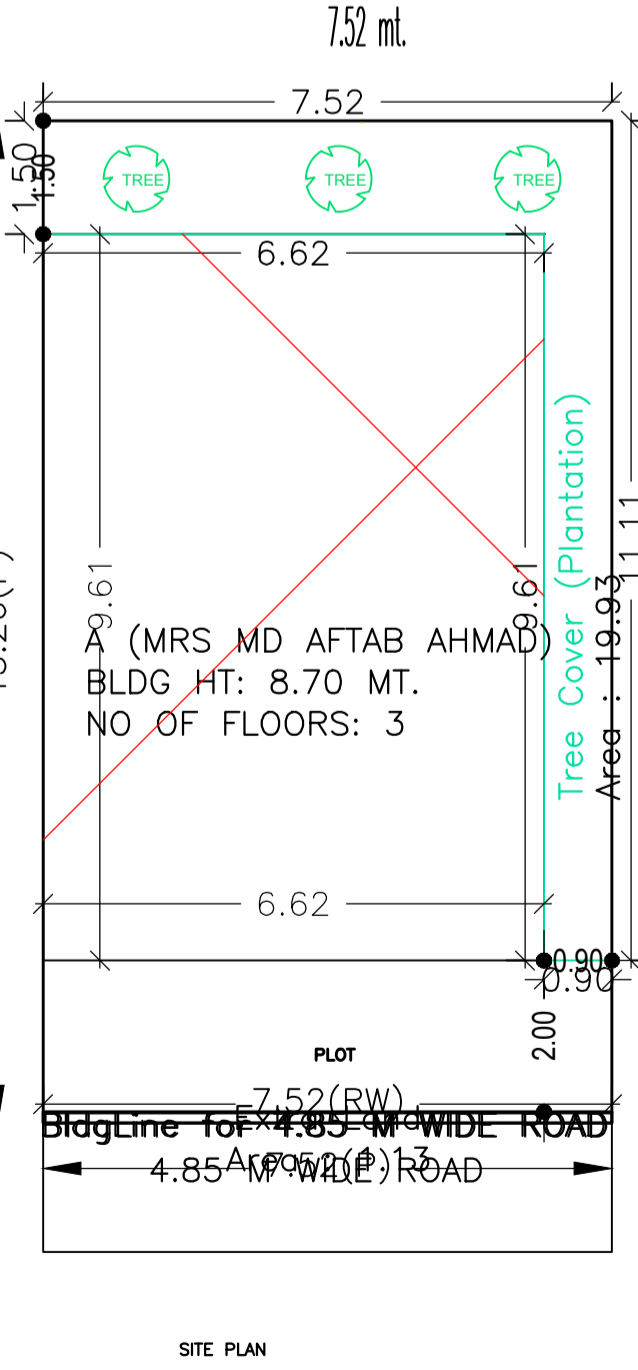
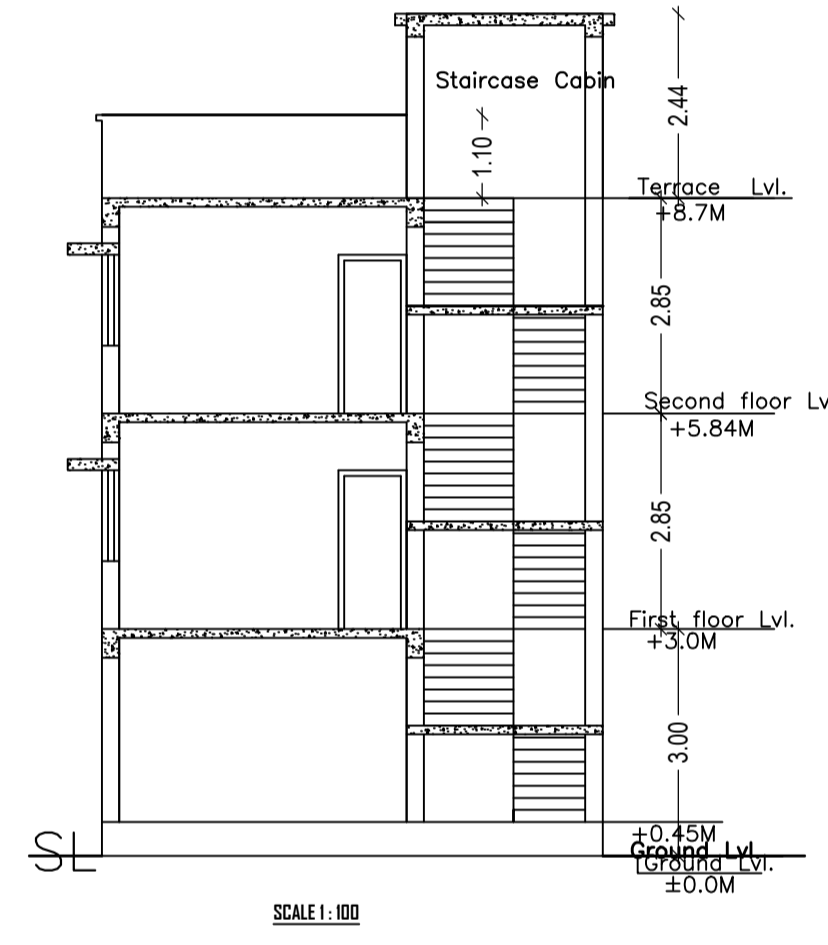
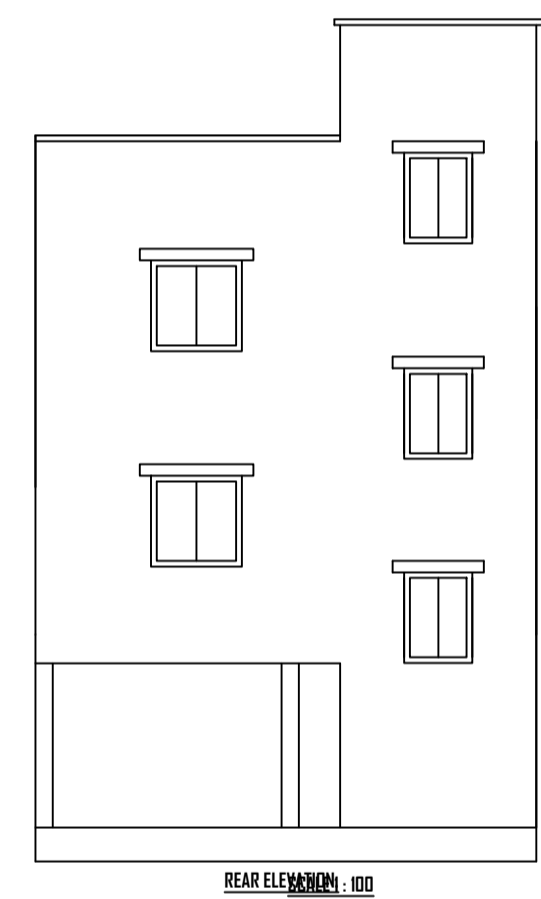
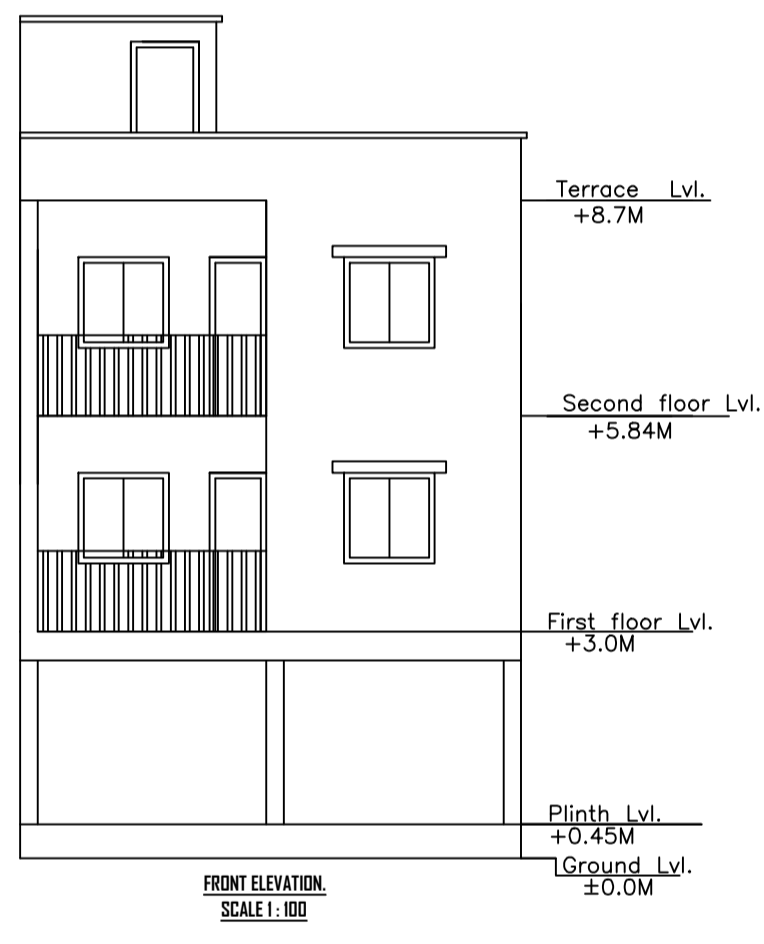
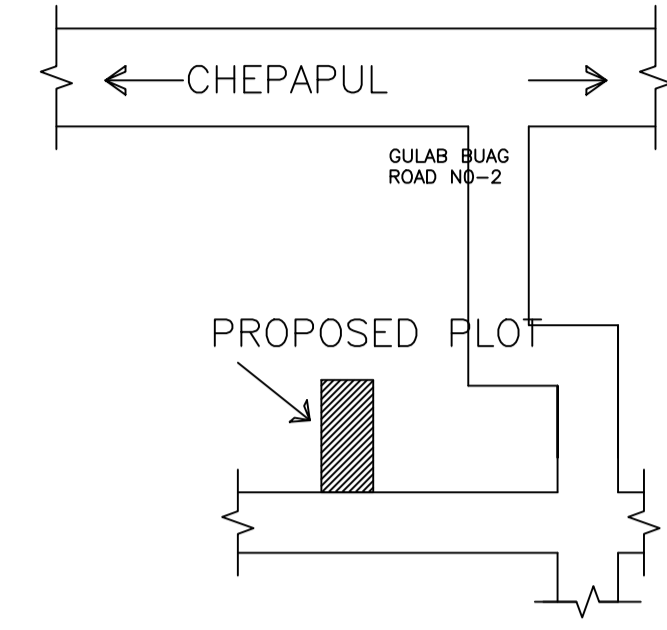
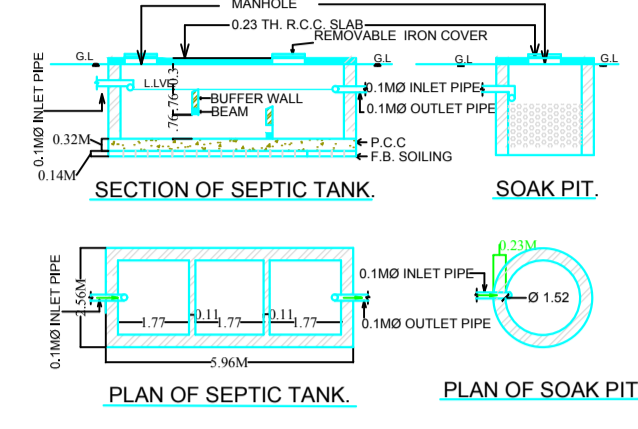
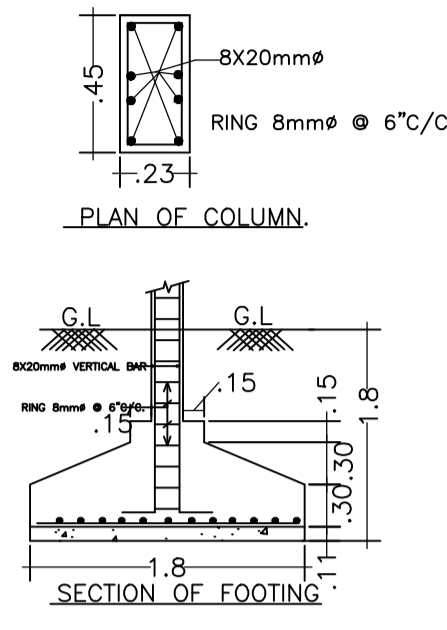

Building USE/SUBUSE Details

Building Name	Building Use	Building SubUse	Building Structure
A (MRS MD AFTAB AHMAD)	Residential	Bungalow/ Dwelling / Non Apartment	Non-Highrise

COLOR INDEX



Buildingwise Floor FAR Details

Floor Name	Building Name		Total	
	Proposed Built Up Area (Sq.mt.)	Proposed FAR Area (Sq.mt.)	Total Proposed Built Up Area (Sq.mt.)	Total FAR Area (Sq.mt.)
Ground Floor	63.65	8.82	63.65	8.82
First Floor	63.65	63.65	63.65	63.65
Second Floor	63.65	63.65	63.65	63.65
Terrace Floor	0.00	0.00	0.00	0.00
<b>Total :</b>	<b>190.95</b>	<b>136.12</b>	<b>190.95</b>	<b>136.12</b>

FAR & Tenement Details (Table 4c-1)

Building	No. of Same Bldg	Total Built Up Area (Sq.mt.)	Deductions (Area in Sq.mt.)	Proposed FAR Area (Sq.mt.)			Total Consumed Additional FAR Area (Sq.mt.)	Tnmt (No.)
				Parking	Resi.	Stair		
A (MRS MD AFTAB AHMAD)	1	190.95	54.83	127.30	8.82	136.12	136.12	01
<b>Grand Total :</b>	<b>1</b>	<b>190.95</b>	<b>54.83</b>	<b>127.30</b>	<b>8.82</b>	<b>136.12</b>	<b>136.12</b>	<b>01</b>

UnitBUA Table for Building :A (MRS MD AFTAB AHMAD)

FLOOR	Name	UnitBUA Type	UnitBUA Area	Carpet Area	No. of Rooms	No. of Tenement
FIRST FLOOR PLAN	SPLIT A	FLAT	112.78	107.82	5	1
SECOND FLOOR PLAN	SPLIT A	FLAT	0.00	0.00	5	0
<b>Total:</b>	-	-	112.78	107.82	10	1

SCHEDULE OF DOOR:

BUILDING NAME	NAME	LENGTH	HEIGHT	NOS
A (MRS MD AFTAB AHMAD)	D2	0.75	2.10	06
A (MRS MD AFTAB AHMAD)	D1	0.90	2.10	04
A (MRS MD AFTAB AHMAD)	D	1.07	2.10	02

SCHEDULE OF WINDOW/VENTILATION:

BUILDING NAME	NAME	LENGTH	HEIGHT	NOS
A (MRS MD AFTAB AHMAD)	V1	0.60	0.60	02
A (MRS MD AFTAB AHMAD)	W2	0.90	1.20	03
A (MRS MD AFTAB AHMAD)	W1	1.20	1.20	10

LTP NAME AND SIGNATURE	STRUCTURAL ENG'S NAME AND SIGNATURE	BUILDER NAME AND SIGNATURE
L K Suman MNAC/ENG/0008/2016		