

AREA STATEMENT MANGO NAC	VERSION NO.: 1.0.30	
	VERSION DATE: 30/06/2018	
PROJECT DETAIL:		
Region: JHARKHAND URBAN LOCAL BODIES	Plot Use: Residential	
District: EAST SINGHBHUM	Plot SubUse: Residential Bldg/Apartment	
Authority: MANGO NAC	Plot/Nearby/Religious/Structure: NA	
Inward No: MNAC/BP/0016/W10/2018	Plot/SubPlot No: 1453 (COLONY SUB PLOT NO:- 1)	
Application Type: General Proposal	North: -	
Project Type: Building Permission	South: -	
Nature of Development: New	East: -	
Location of Development Area: Old Area	West: -	
AREA OF PLOT (Minimum)	(A)	SQ.MT.
NET AREA OF PLOT(Gross Plot Area - Deduction from Gross Plot area)	(A-Deductions)	188.09
Deduction for Balance Plot Area(from Gross Plot Area)		
Common Plot		26.01
Total		26.01
BALANCE AREA OF PLOT(Net Plot Area - Recreational/Amenity space)	(A-Deductions)	162.08
PLOT AREA FOR COVERAGE(Net Plot Area)	(A-Deductions)	188.09
Plot Area for FAR (Net Plot Area + Road Widening Area)	(A-Deductions)	188.09
COVERAGE CHECK		
Permissible Coverage area (70.00 %)		131.66
Proposed Coverage Area (55.85 %)		105.04
Total Prop. Coverage Area (55.85 %)		105.04
Balance coverage area (14.15 %)		26.62
FAR CHECK		
Perm. FAR Area (2.50)		470.22
Total Perm. FAR area		470.22
Residential FAR		210.07
Proposed FAR Area		210.07
Total Proposed FAR Area		210.07
Consumed FAR (Factor)		1.12
Balance FAR Area		260.15
BUILT UP AREA CHECK		
Total Proposed BuiltUp Area		210.08
ARCHITECT (Regd)	NIKHIL SHUKLA	
ENGINEER (Regd)		
SUPERVISOR (Regd)		
OWNER (Regd)	MR VIDHYA SAGAR LABH	
DEVELOPMENT AUTHORITY		LOCAL BODY

Proposal Basic Information	
Proposal File No.	MNAC/BP/0016/W10/2018
Owner Name	MR VIDHYA SAGAR LABH
Khata No	425
Plot No	1453 (COLONY SUB PLOT NO:- 1)
Village Name	Balguma
Use	Residential
SubUse	Residential Bldg/Apartment

Building USE/SUBUSE Details

Building Name	Building Use	Building SubUse	
A (MR VIDHYA SAGAR LABH)	Residential	Residential Bldg/Apartment	Non-Highrise

FAR & Tenement Details (Table 4c-1)

Building	No. of Same Bldg	Total Built Up Area (Sq.mt.)	Proposed FAR Area (Sq.mt.)	Total FAR Area (Sq.mt.)	Total Consumed Additional FAR Area (Sq.mt.)	Tnmt (No.)
			Resi.			
A (MR VIDHYA SAGAR LABH)	1	210.08	210.08	210.08	210.08	01
Grand Total	1	210.08	210.08	210.08	210.08	01

COLOR INDEX	
PLOT BOUNDARY	Black
ABUTTING ROAD	Green
PROPOSED CONSTRUCTION	Red
COMMON PLOT	Yellow
ROAD WIDENING AREA	Blue
EXISTING (To be retained)	Light Blue
EXISTING (To be demolished)	Orange

Buildingwise Floor FAR Details

Floor Name	Building Name		Total	
	Proposed Built Up Area (Sq.mt.)	Proposed FAR Area (Sq.mt.)	Total Proposed Built Up Area (Sq.mt.)	Total FAR Area (Sq.mt.)
Ground Floor	105.04		105.04	105.04
First Floor	105.04	105.04	105.04	105.04
Terrace Floor	0.00	0.00	0.00	0.00
Total		210.08	210.08	210.08

LTP NAME AND SIGNATURE	STRUCTURAL ENG'S NAME AND SIGNATURE	BUILDER NAME AND SIGNATURE	DIGITAL SIGNATURE
NIKHIL SHUKLA MNAC/ARC/0002/2018			

Proposal Basic Information	
Proposal File No.	MNAC/BP/0016/W10/2018
Owner Name	MR VIDHYA SAGAR LABH
Khata No	425
Plot No	1453 (COLONY SUB PLOT NO.- 1)
Village Name	Baliguma
Use	Residential
SubUse	Residential Bldg/Apartment

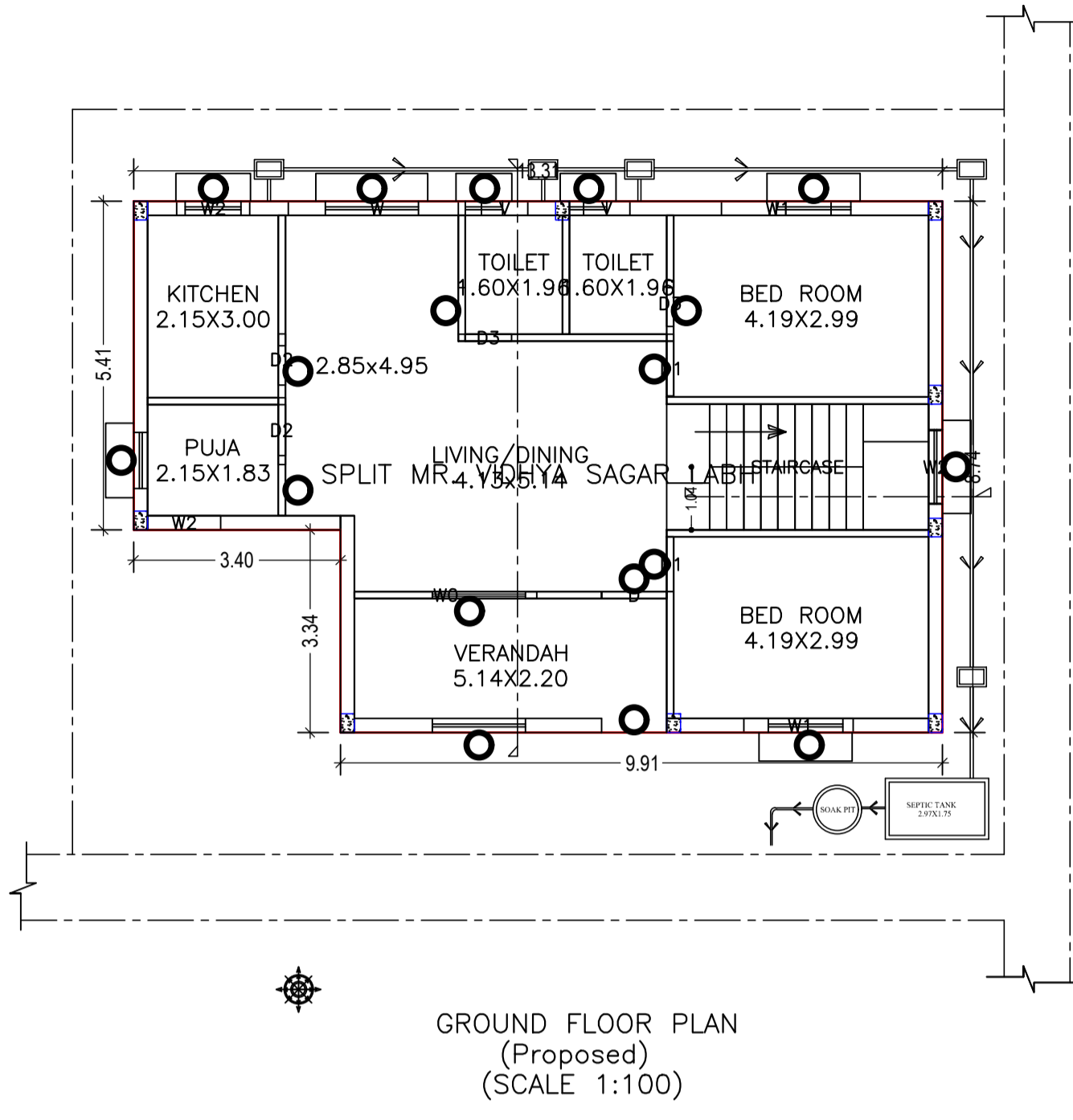

FIRST FLOOR PLAN (Proposed) (SCALE 1:100)

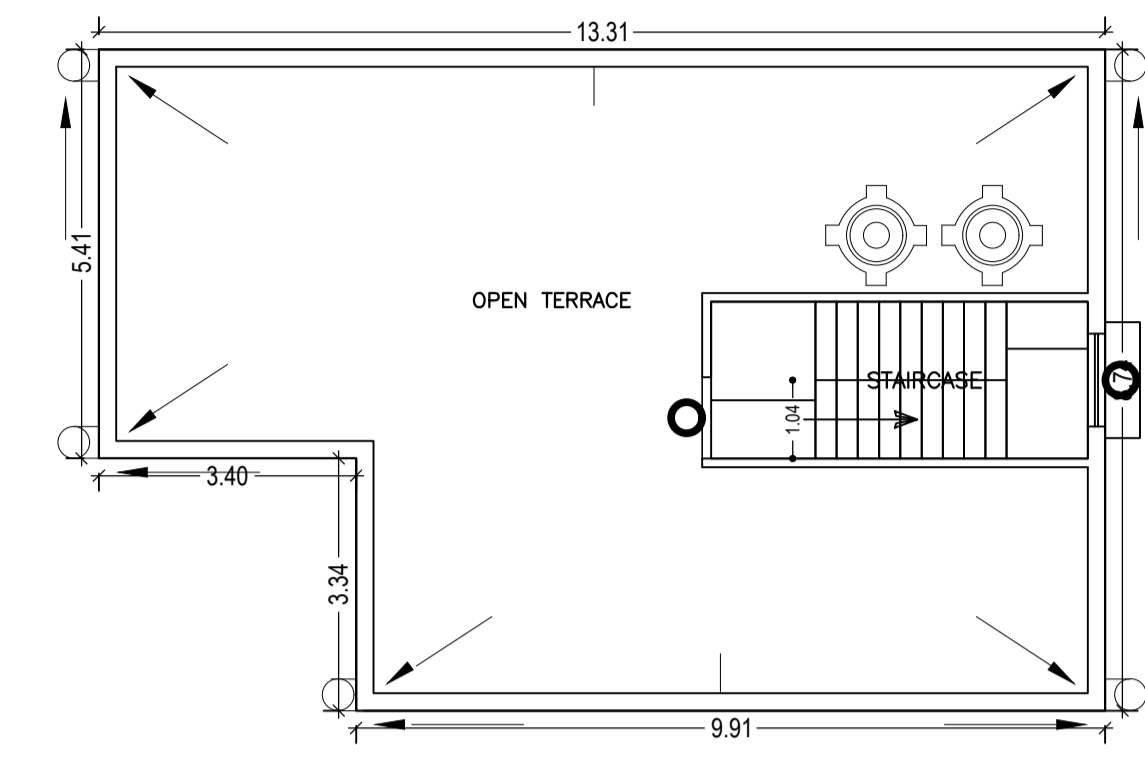

TERRACE FLOOR PLAN (SCALE 1:100)

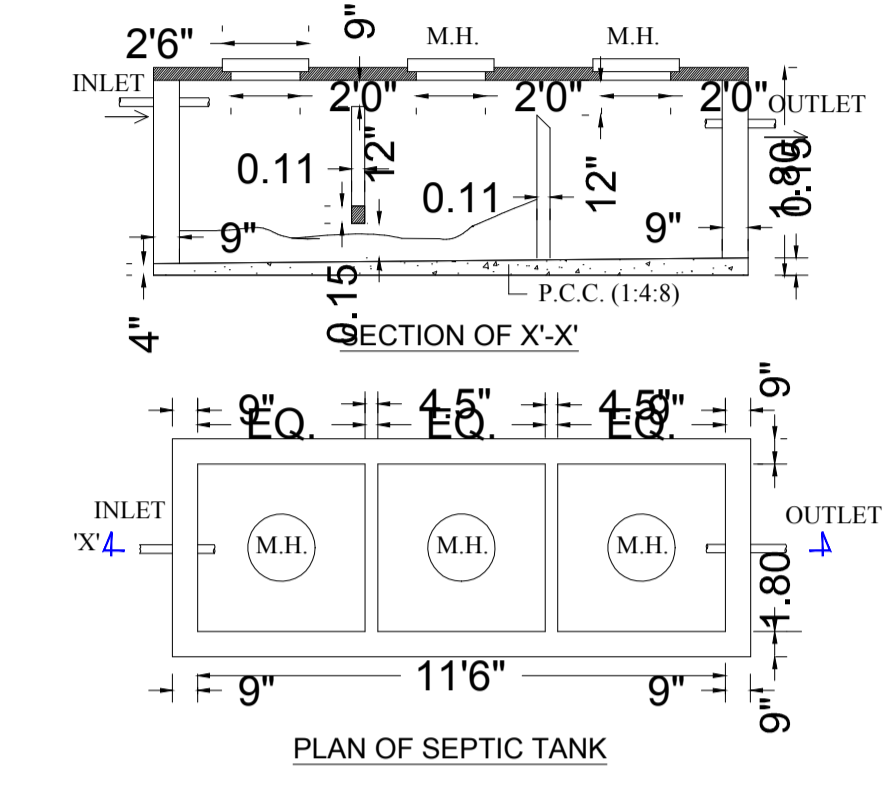

SCHEDULE OF DOOR:

BUILDING NAME	NAME	LENGTH	HEIGHT	NOS
A (MR VIDHYA SAGAR LABH)	D3	0.76	2.13	04
A (MR VIDHYA SAGAR LABH)	D2	0.84	2.13	04
A (MR VIDHYA SAGAR LABH)	D1	0.90	2.13	04
A (MR VIDHYA SAGAR LABH)	D	1.07	2.13	02

SCHEDULE OF WINDOW/VENTILATION:

BUILDING NAME	NAME	LENGTH	HEIGHT	NOS
A (MR VIDHYA SAGAR LABH)	V	0.76	0.76	04
A (MR VIDHYA SAGAR LABH)	W2	1.20	2.50	06
A (MR VIDHYA SAGAR LABH)	W1	1.80	2.50	04
A (MR VIDHYA SAGAR LABH)	W	2.80	2.50	02
A (MR VIDHYA SAGAR LABH)	W0	3.00	2.50	02

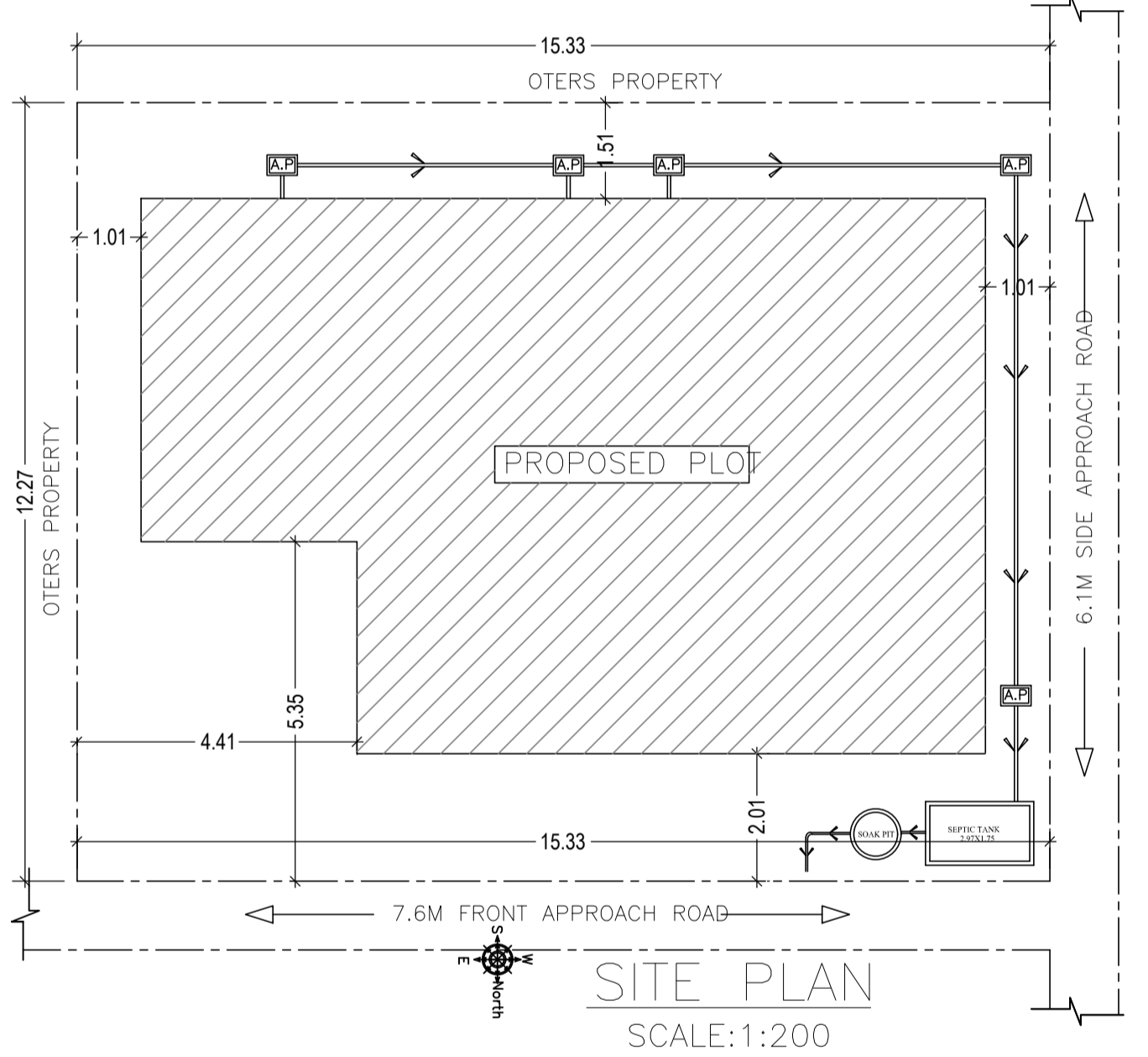

SITE PLAN SCALE:1:200

Building :A (MR VIDHYA SAGAR LABH)

Floor Name	Total Built Up Area (Sq.mt.)	Proposed FAR Area (Sq.mt.) Resi.	Total FAR Area (Sq.mt.)	Total Consumed Additional FAR Area (Sq.mt.)	Tnmt (No.)
Ground Floor	105.04	105.04	105.04	105.04	01
First Floor	105.04	105.04	105.04	105.04	00
Terrace Floor	0.00	0.00	0.00	0.00	00
Total :	210.08	210.08	210.08	210.08	01
Total Number of Same Buildings :	1				
Total :	210.08	210.08	210.08	210.08	01

UnitBUA Table for Building :A (MR VIDHYA SAGAR LABH)

FLOOR	Name	UnitBUA Type	UnitBUA Area	Carpet Area	No. of Rooms	No. of Tenement
GROUND FLOOR PLAN	SPLIT MR. VIDHYA SAGAR LABH	FLAT	172.73	166.85	8	1
FIRST FLOOR PLAN	SPLIT MR. VIDHYA SAGAR LABH	FLAT	0.00	0.00	8	0
Total:	-	-	172.73	166.85	16	

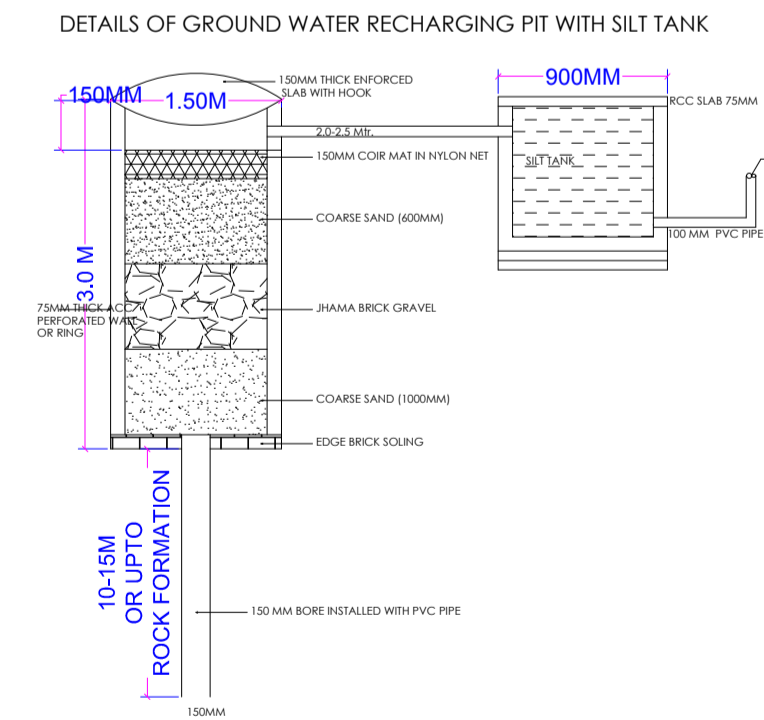
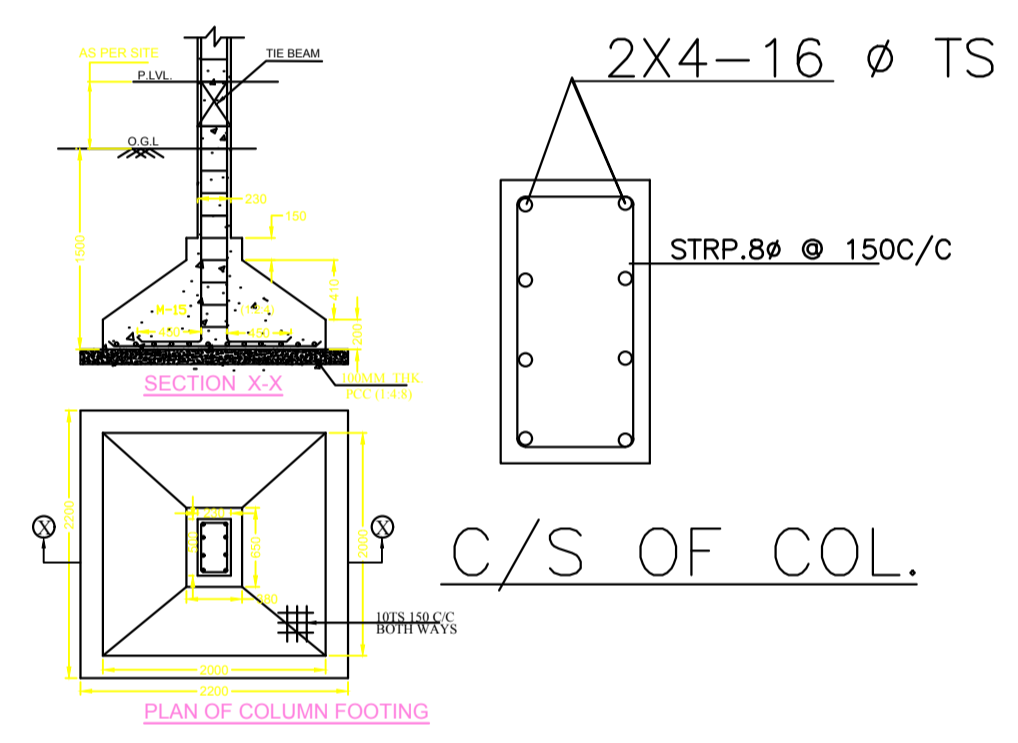

LTP NAME AND SIGNATURE	STRUCTURAL ENG'S NAME AND SIGNATURE	BUILDER NAME AND SIGNATURE	DIGITAL SIGNATURE
NIKHIL SHUKLA MNAC/ARC/0002/2018			