

SECTION OF SURFACE WATER PERCOLATION SYSTEM TO SUB-SOIL

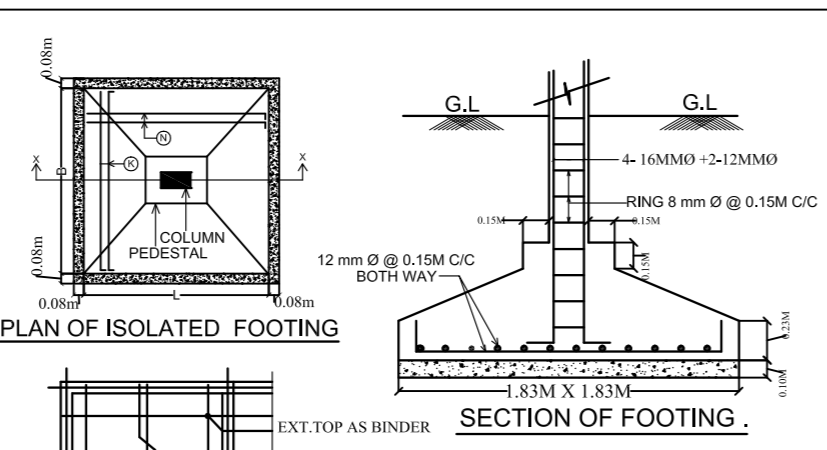

PLAN OF ISOLATED FOOTING

SCHEDULE OF DOOR & WINDOW				
TYPE	WIDTH	HT.	SILL	DESCRIPTION
D	1.07	2.13	0	WOODEN FLUSH DOOR
D1	0.99	2.13	0	WOODEN FLUSH DOOR
D2	0.76	2.13	0	WOODEN FLUSH DOOR
W	1.52	1.52	0.61	GLAZED WINDOW
W1	1.22	1.52	0.61	GLAZED WINDOW
W2	0.91	1.52	0.61	GLAZED WINDOW
V	0.76	0.61	1.52	GLAZED VENTILATOR

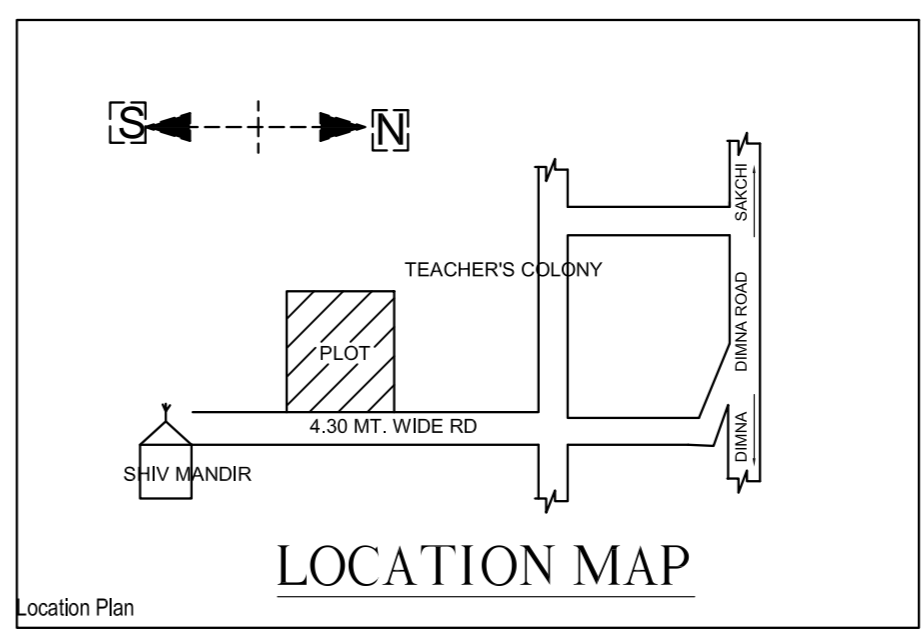

LOCATION MAP

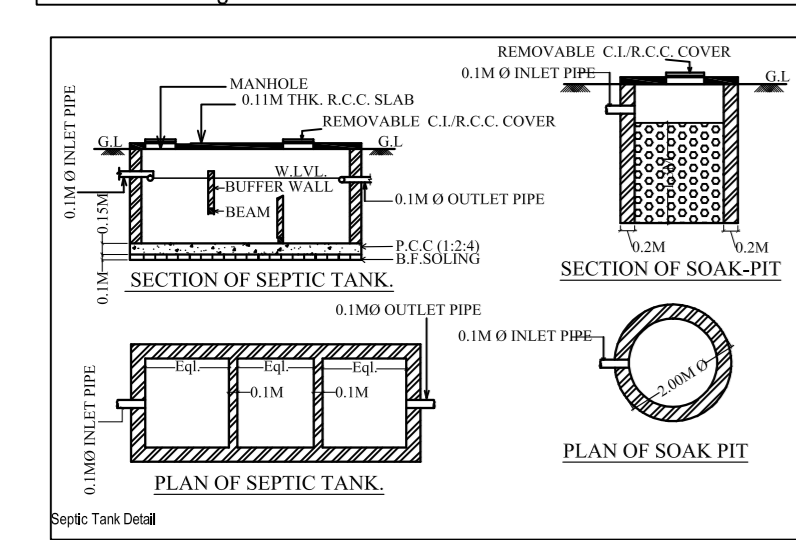

Rain Water Storage Tank Detail

SCHEDULE FOR DRAINAGE PLAN	
NOTIFICATION	DISCRPTION
	INSPECTION CHAMBER
	RECHARGE PIT
	RAIN WATER PIPE
	OVERFLOW OUTLET FOR RECHARGE PIT
	OVERFLOW OUTLET FOR SEPTIC TANK
	SOAK PIT
	DRAIN PIPELINE LAYOUT

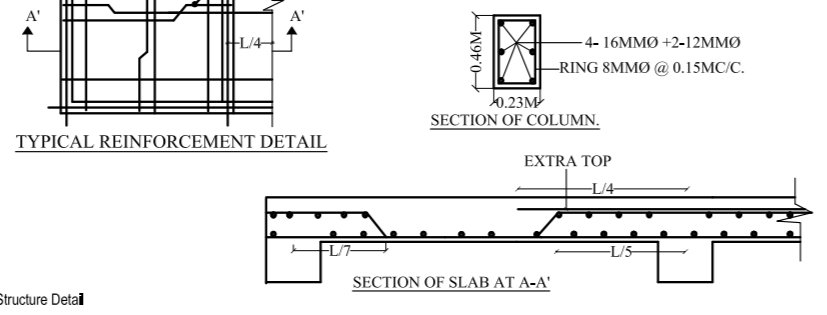

SECTION OF FOOTING

COLCULATION FOR WATER TANK  
 CONSIDERING FOR 15 PERSONS = 15 X 135 = 2025 LTS.  
 APPROVIDED = 5,000 LTS.

COLCULATION FOR SEPTIC TANK  
 CONSIDERING FOR 15 PERSONS = 15 X 0.083 = 1.245 CUM  
 APPROVIDED = 2.78X1.06X1.5 = 4.4202 CUM

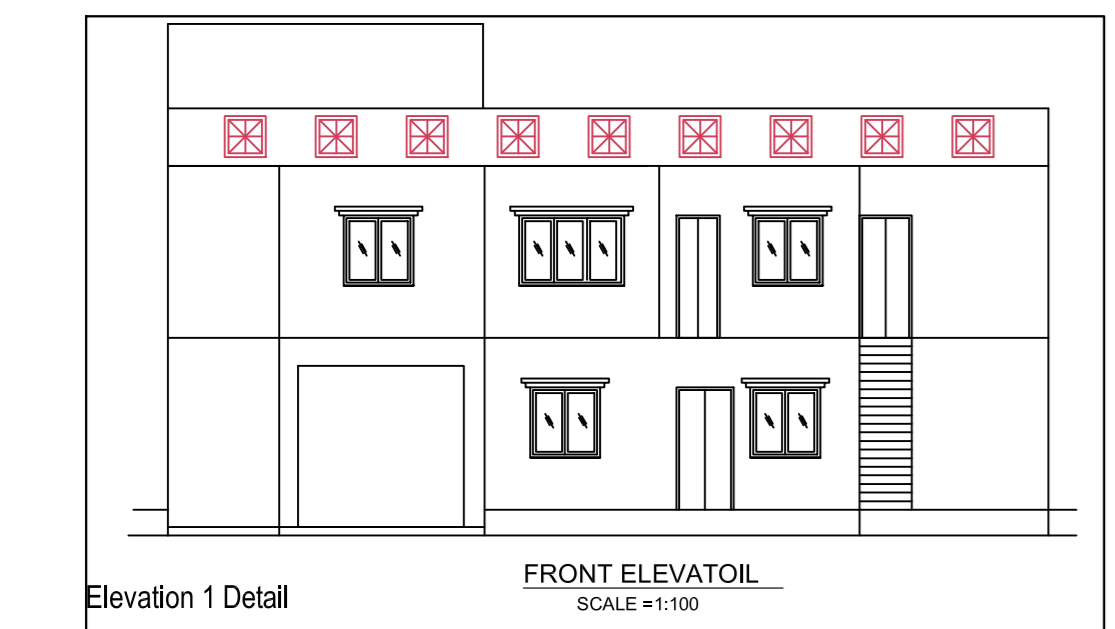

Elevation 1 Detail

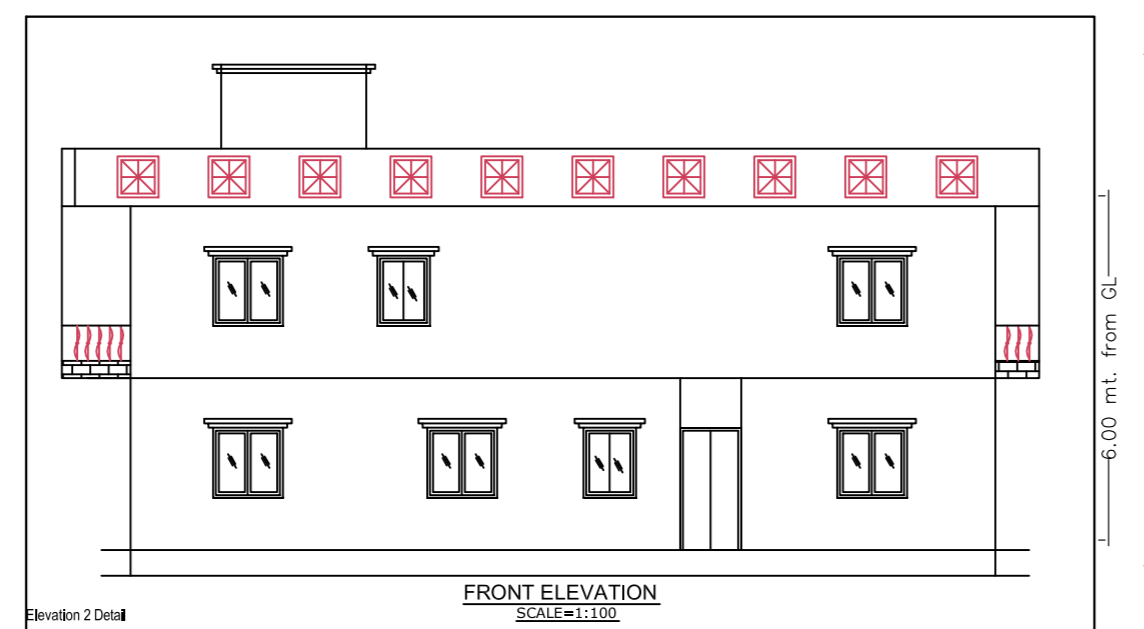

Elevation 2 Detail

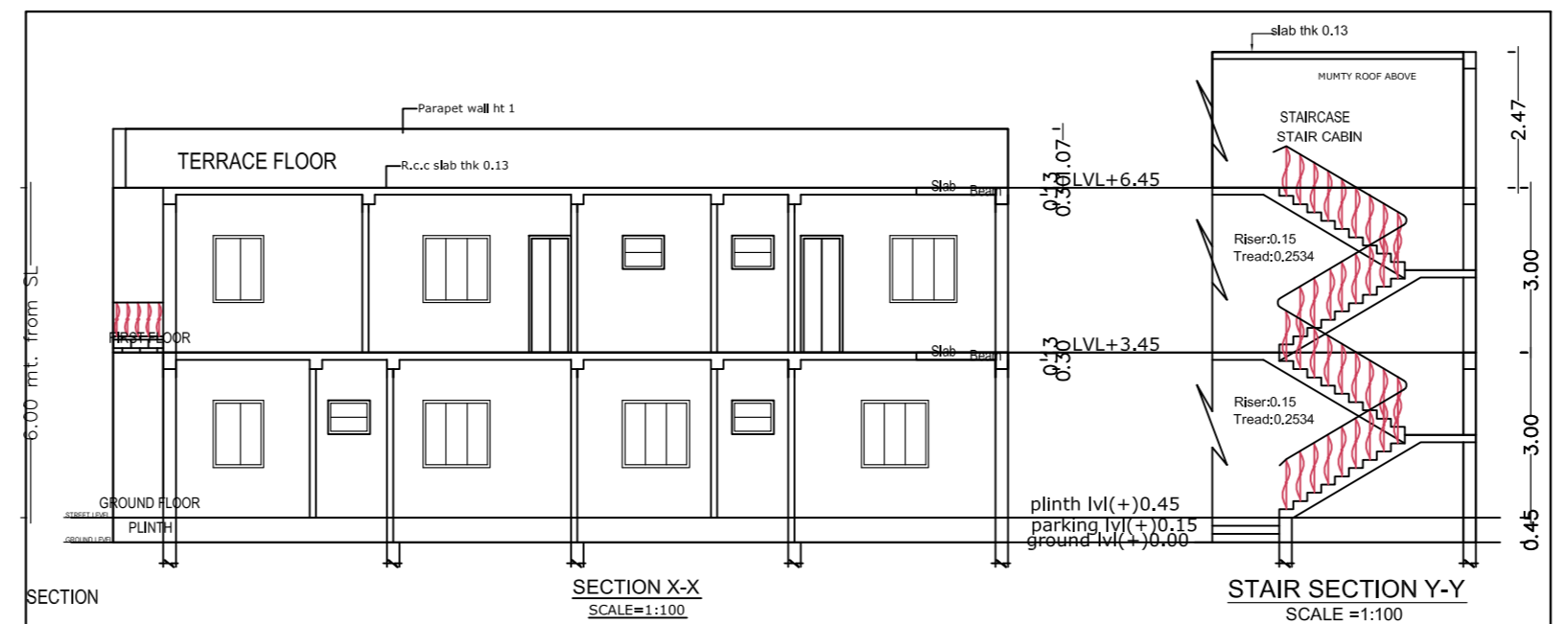

SECTION

SECTION X-X

STAIR SECTION Y-Y

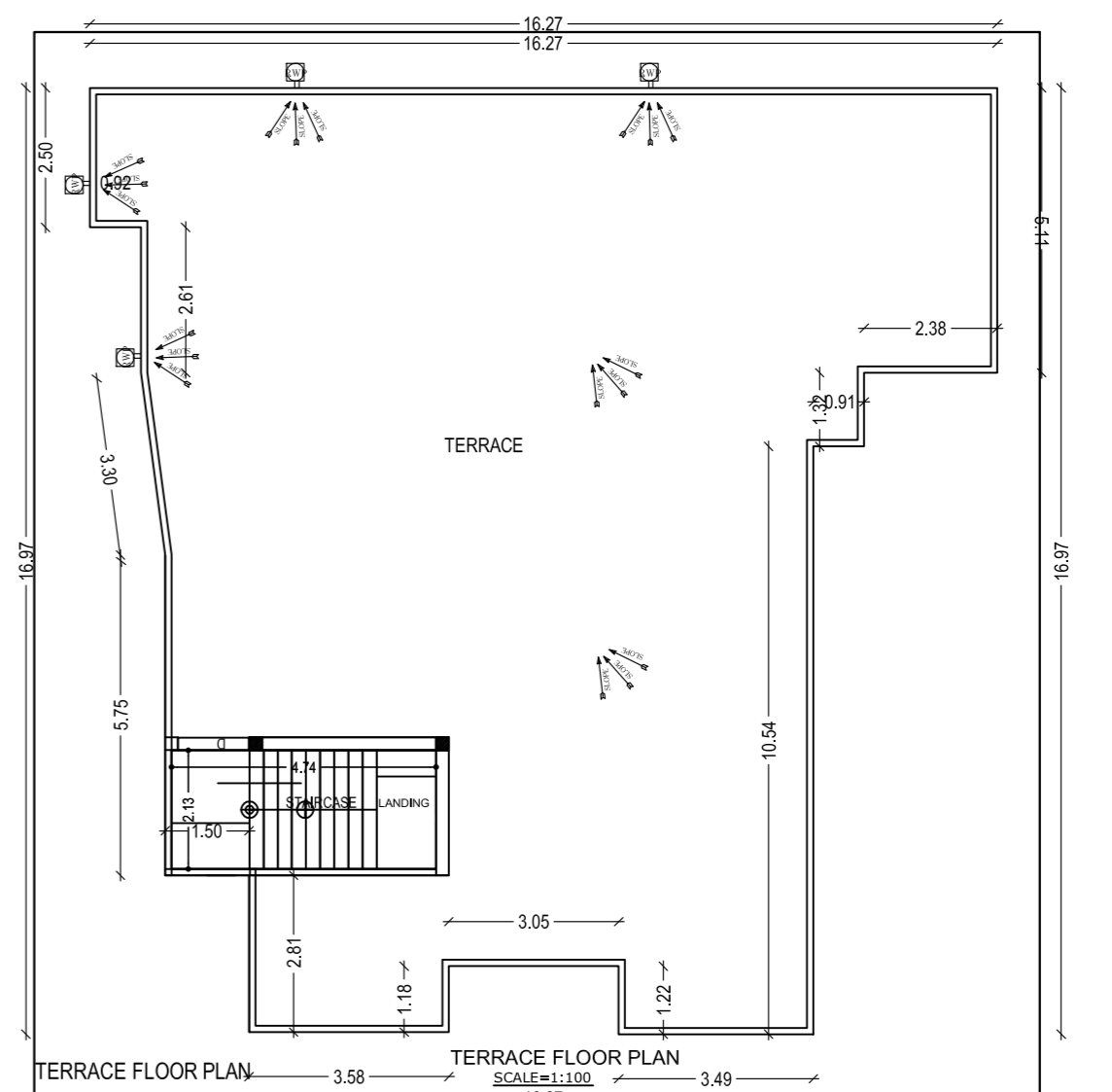

TERRACE FLOOR PLAN

TERRACE FLOOR PLAN

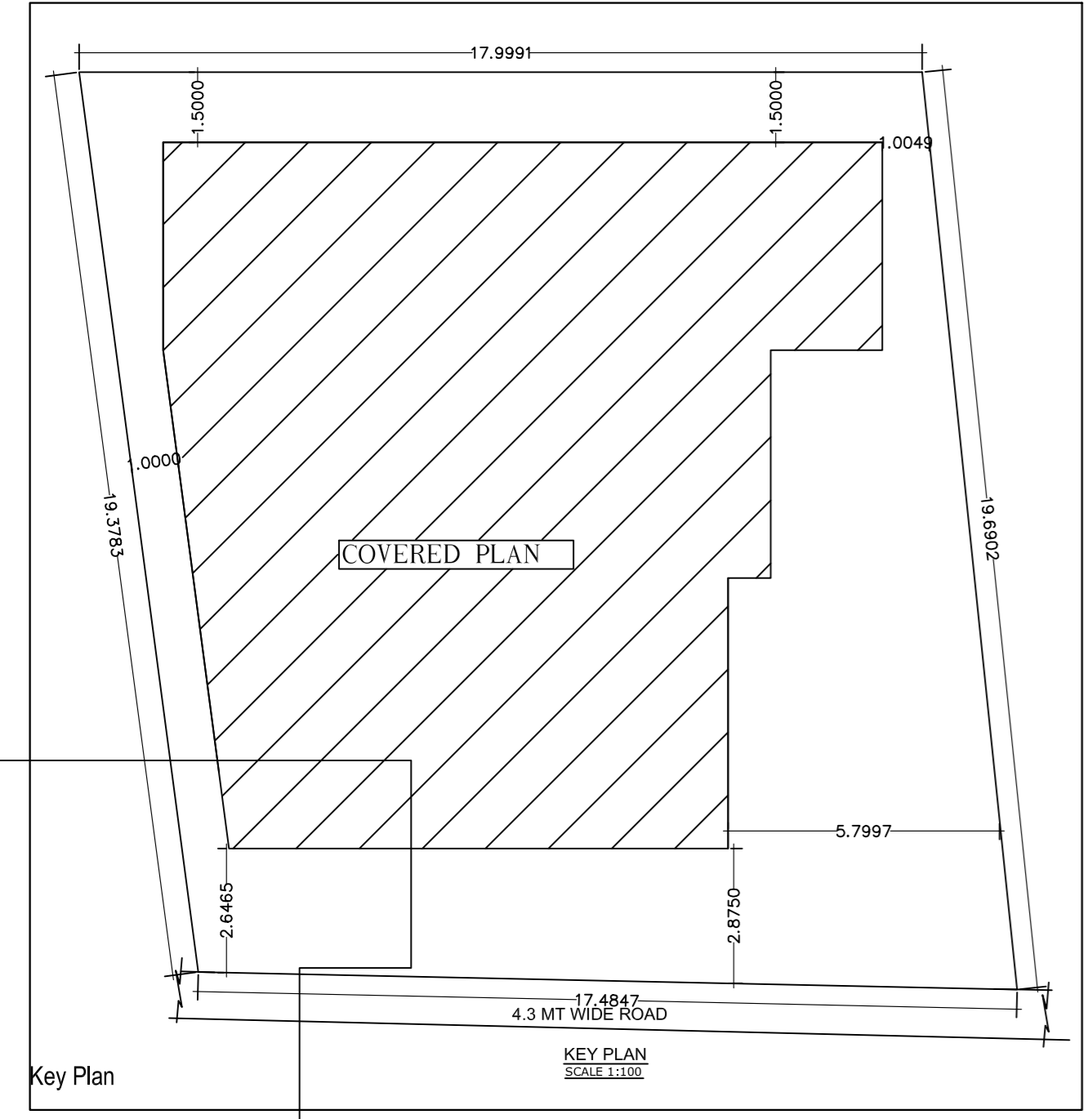

Key Plan

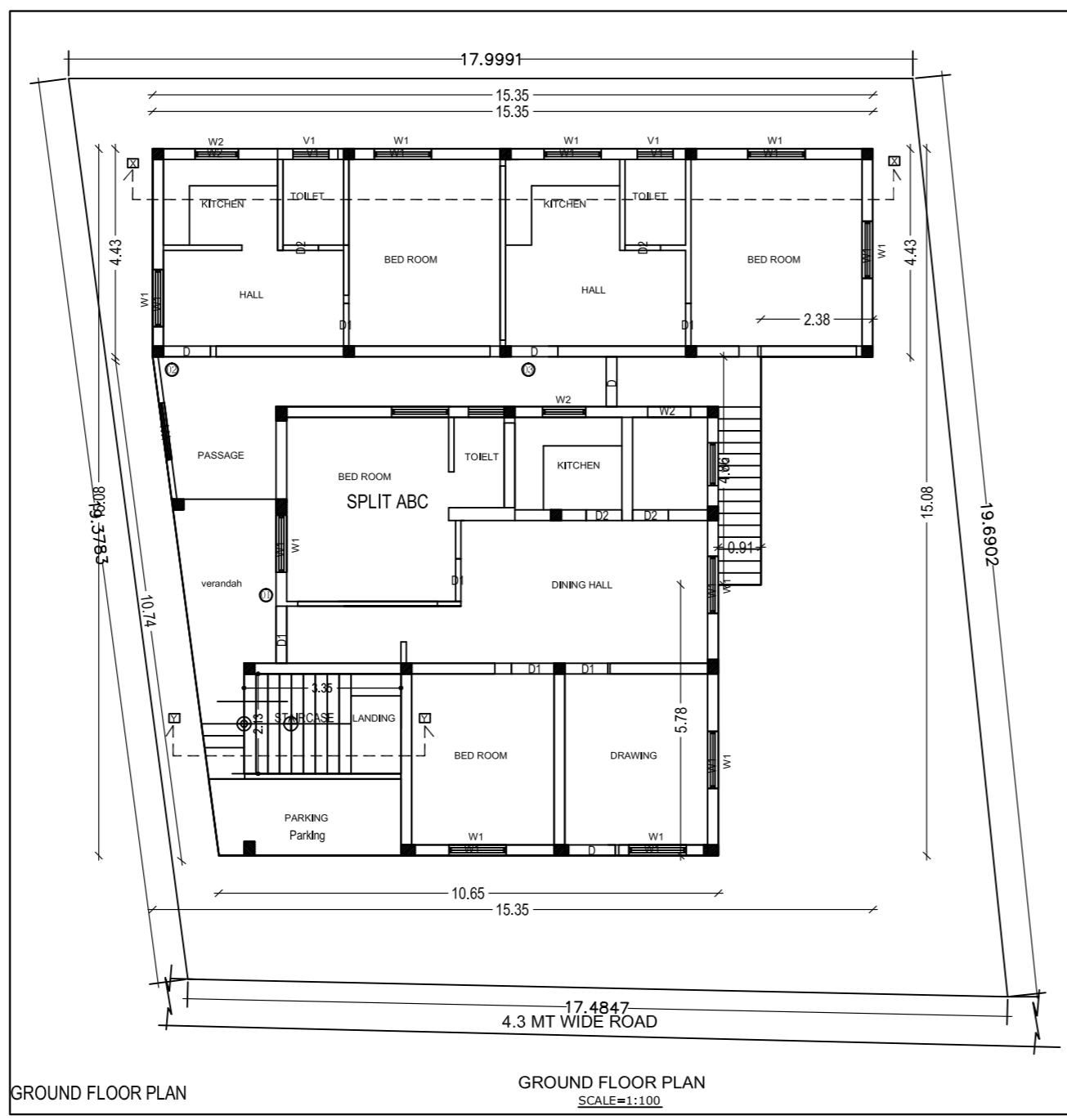

GROUND FLOOR PLAN

GROUND FLOOR PLAN

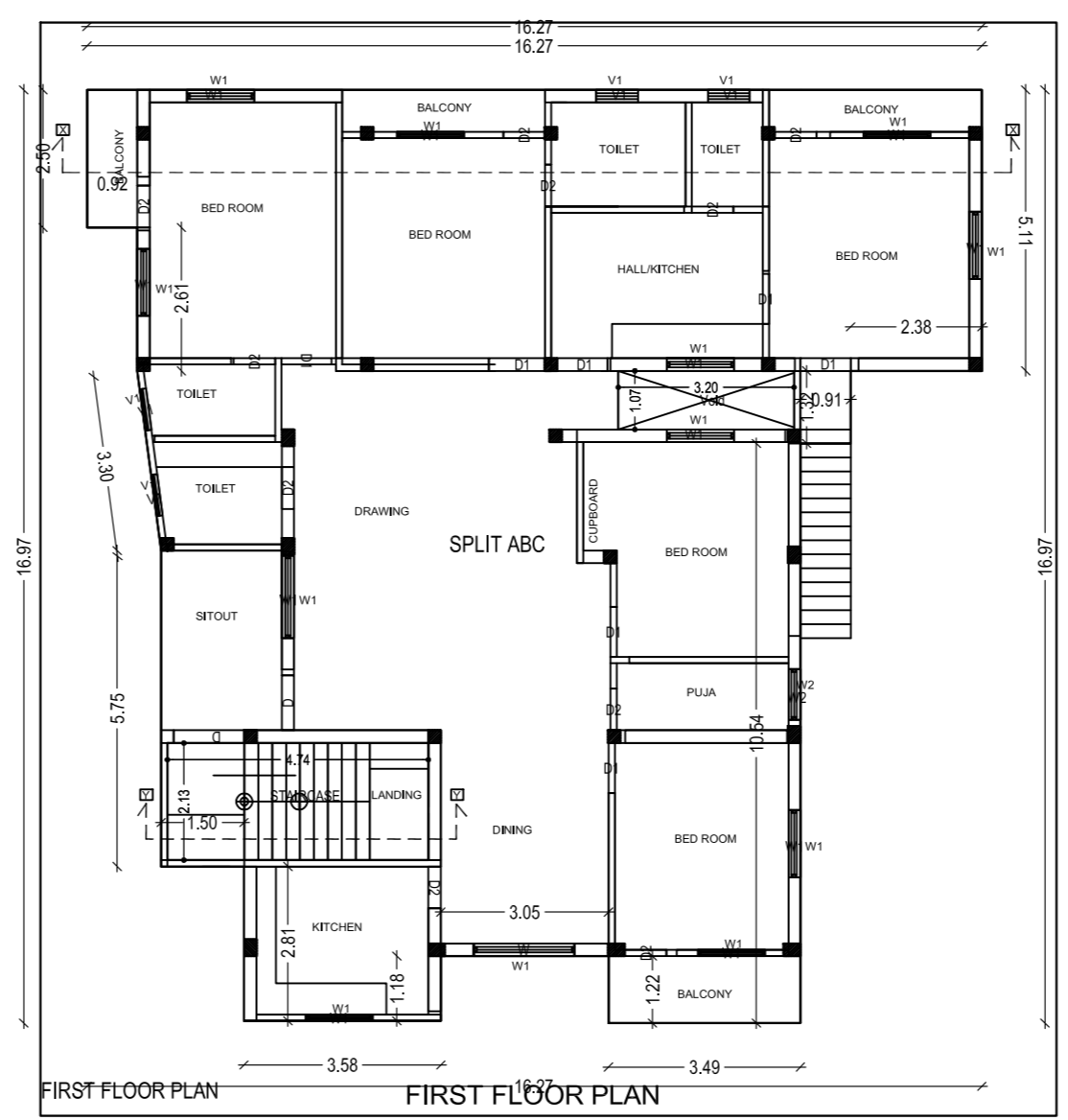

FIRST FLOOR PLAN

FIRST FLOOR PLAN

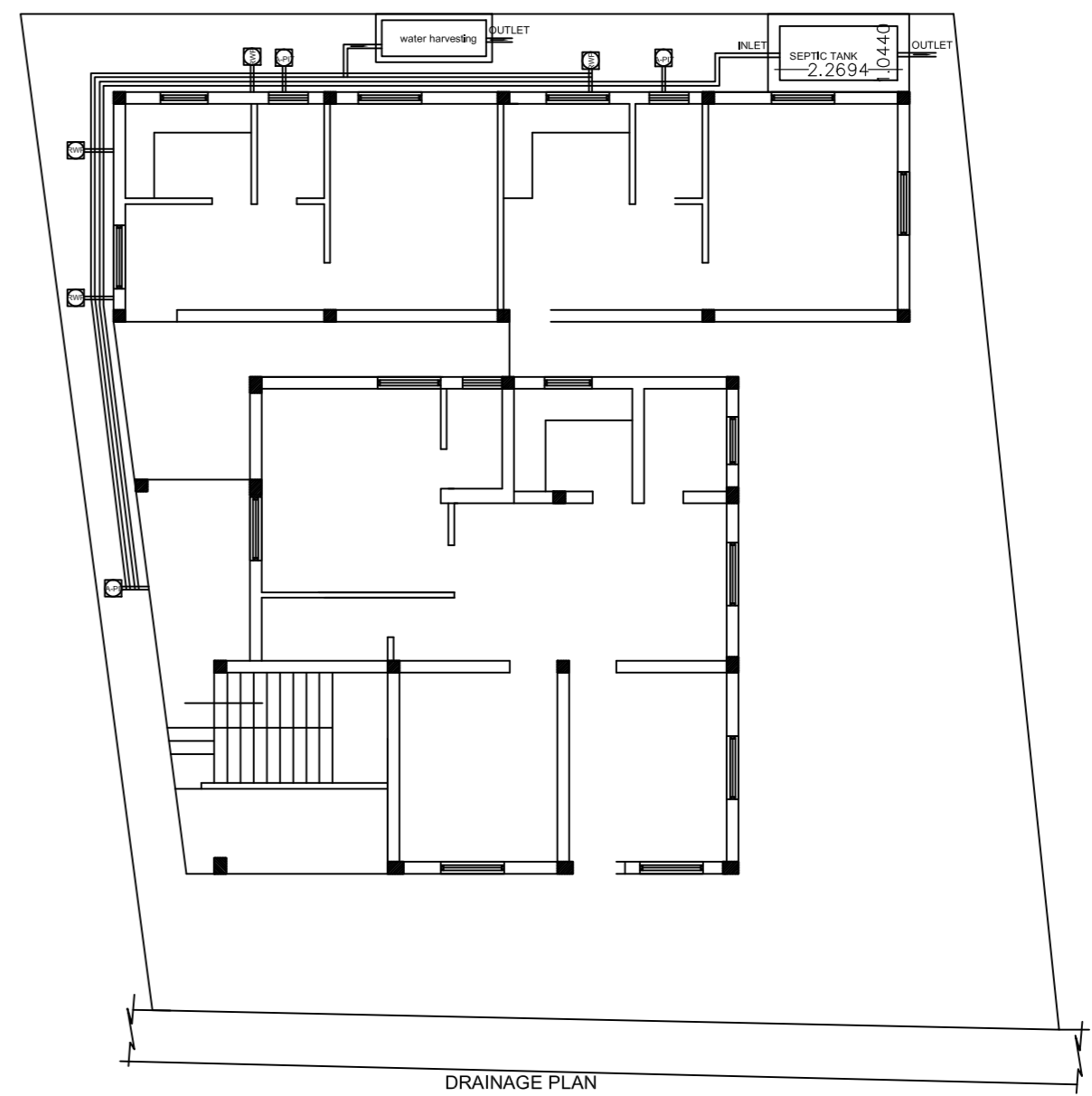

DRAINAGE PLAN

PROPOSED RESIDENTIAL BUILDING PLAN FOR	
LAND OWNER	SIGNATURE
MR. VIKASH KUMAR SINGH S/O: LATE BIJAY KUMAR SINGH	
MRS. RAJ KUMARI DEVI W/O: LATE BIJAY KUMAR SINGH	
DETAILS OF PLOT :- PLOT NO:-3231 KHATA NO :- 214 MOUZA :- MANGO WARD NO :- 10 THANA NO:- 1641. P.S:- MANGO DISTRICT :- EAST SINGHBHUM, JHARKHAND	
CONTENTS :- * SITE PLAN * GROUND FLOOR PLAN * FIRST FLOOR PLAN * SECOND FLOOR PLAN * DRAINAGE PLAN * GROUND COVERAGE * CALCULATION * F.A.R. CALCULATION	
* TERRACE PLAN * FRONT ELEVATION * SIDE ELEVATION * SECTION "X-X" * SECTION "Y-Y" * LOCATION MAP * PART MOUZA PLAN	
SH. NO	1/1
PLANNER	