

Proposal Basic Information

| | |
|-------------------|------------------------------------|
| Proposal File No. | MNAC/BP/0002/W09/2019 |
| Owner Name | SANJAY KUMAR |
| Khata No | 303 |
| Plot No | 1790 |
| Village Name | Dimna |
| Use | Residential |
| SubUse | Bungalow/ Dwelling / Non Apartment |

| | |
|--|--|
| AREA STATEMENT MANGO MUNICIPAL CORPORATION | VERSION NO. : 1.0.42 VERSION DATE: 29/04/2019 |
| PROJECT DETAIL: | |
| Region : JHARKHAND URBAN LOCAL BODIES | Plot Use: Residential |
| District: EAST SINGHBHUM | Plot SubUse: Bungalow/ Dwelling / Non Apartment |
| Authority: MANGO MUNICIPAL CORPORATION | PlotNearby/ReligiousStructure: NA |
| Inward No: MNAC/BP/0002/W09/2019 | Plot/SubPlot No: 1790 |
| Application Type: General Proposal | North: Plot No. - 1767 |
| Project Type: Building Permission | South: Road Width - 5.80 |
| Nature of Development: New | East: Plot No. - 1745 |
| Location of Development Area: Old Area | West: Plot No. - 1789 |
| AREA DETAILS: | |
| AREA OF PLOT (Minimum) | (A) 99.50 SQ.MT. |
| NET AREA OF PLOT(Gross Plot Area - Deduction from Gross Plot area) | (A-Deductions) 99.50 |
| Deduction for Balance Plot Area(from Gross Plot Area) | |
| Common Plot | 18.47 |
| Total | 18.47 |
| BALANCE AREA OF PLOT(Net Plot Area - Recreational/Amenity space) | (A-Deductions) 81.03 |
| PLOT AREA FOR COVERAGE(Net Plot Area) | (A-Deductions) 99.50 |
| Plot Area for FAR (Net Plot Area + RoadWidening Area) | (A-Deductions) 99.50 |
| COVERAGE CHECK | |
| Permissible Coverage area (70.00 %) | 69.65 |
| Proposed Coverage Area (52.92 %) | 52.66 |
| Total Prop. Coverage Area (52.92 %) | 52.66 |
| Balance coverage area (17.08 %) | 16.99 |
| FAR CHECK | |
| Perm. FAR Area (1.80) | 179.10 |
| Total Perm. FAR area | 179.10 |
| Residential FAR | 52.66 |
| Proposed FAR Area | 62.67 |
| Total Proposed FAR Area | 62.67 |
| Consumed FAR (Factor) | 0.63 |
| Balance FAR Area | 116.43 |
| BUILT UP AREA CHECK | |
| Total Proposed BuiltUp Area | 105.32 |
| ARCHITECT (Regd) | Chandrika Sharma |
| ENGINEER (Regd) | |
| SUPERVISOR (Regd) | |
| OWNER (Regd) | SANJAY KUMAR |
| DEVELOPMENT AUTHORITY LOCAL BODY | |

| COLOR INDEX | |
|-----------------------------|--------|
| PLOT BOUNDARY | Black |
| ABUTTING ROAD | Green |
| PROPOSED CONSTRUCTION | Red |
| COMMON PLOT | Yellow |
| ROAD WIDENING AREA | Blue |
| EXISTING (To be retained) | Orange |
| EXISTING (To be demolished) | Purple |

Buildingwise Floor FAR Details

| Floor Name | Building Name A (SANJAY KUMAR) | | Total | |
|--------------------------|-----------------------------------|----------------------------|---------------------------------------|-------------------------|
| | Proposed Built Up Area (Sq.mt.) | Proposed FAR Area (Sq.mt.) | Total Proposed Built Up Area (Sq.mt.) | Total FAR Area (Sq.mt.) |
| Ground And Parking Floor | 52.66 | 10.00 | 52.66 | 10.00 |
| First Floor | 52.66 | 52.66 | 52.66 | 52.66 |
| Terrace Floor | 0.00 | 0.00 | 0.00 | 0.00 |
| Total : | 105.32 | 62.66 | 105.32 | 62.66 |

Building USE/SUBUSE Details

| Building Name | Building Use | Building SubUse | Building Structure |
|------------------|--------------|------------------------------------|--------------------|
| A (SANJAY KUMAR) | Residential | Bungalow/ Dwelling / Non Apartment | Non-Highrise |

FAR & Tenement Details (Table 4c-1)

| Building | No. of Same Bldg | Total Built Up Area (Sq.mt.) | Deductions (Area in Sq.mt.) | | Proposed FAR Area (Sq.mt.) | Add Area in FAR (Sq.mt.) | Total FAR Area (Sq.mt.) | Total Consumed Additional FAR Area (Sq.mt.) | Tnmt (No.) |
|------------------|------------------|------------------------------|-----------------------------|-------|----------------------------|--------------------------|-------------------------|---|------------|
| | | | Parking | Resi. | | | | | |
| A (SANJAY KUMAR) | 1 | 105.32 | 42.66 | 52.66 | 10.00 | 62.66 | 62.66 | 01 | |
| Grand Total : | 1 | 105.32 | 42.66 | 52.66 | 10.00 | 62.66 | 62.66 | 01 | |

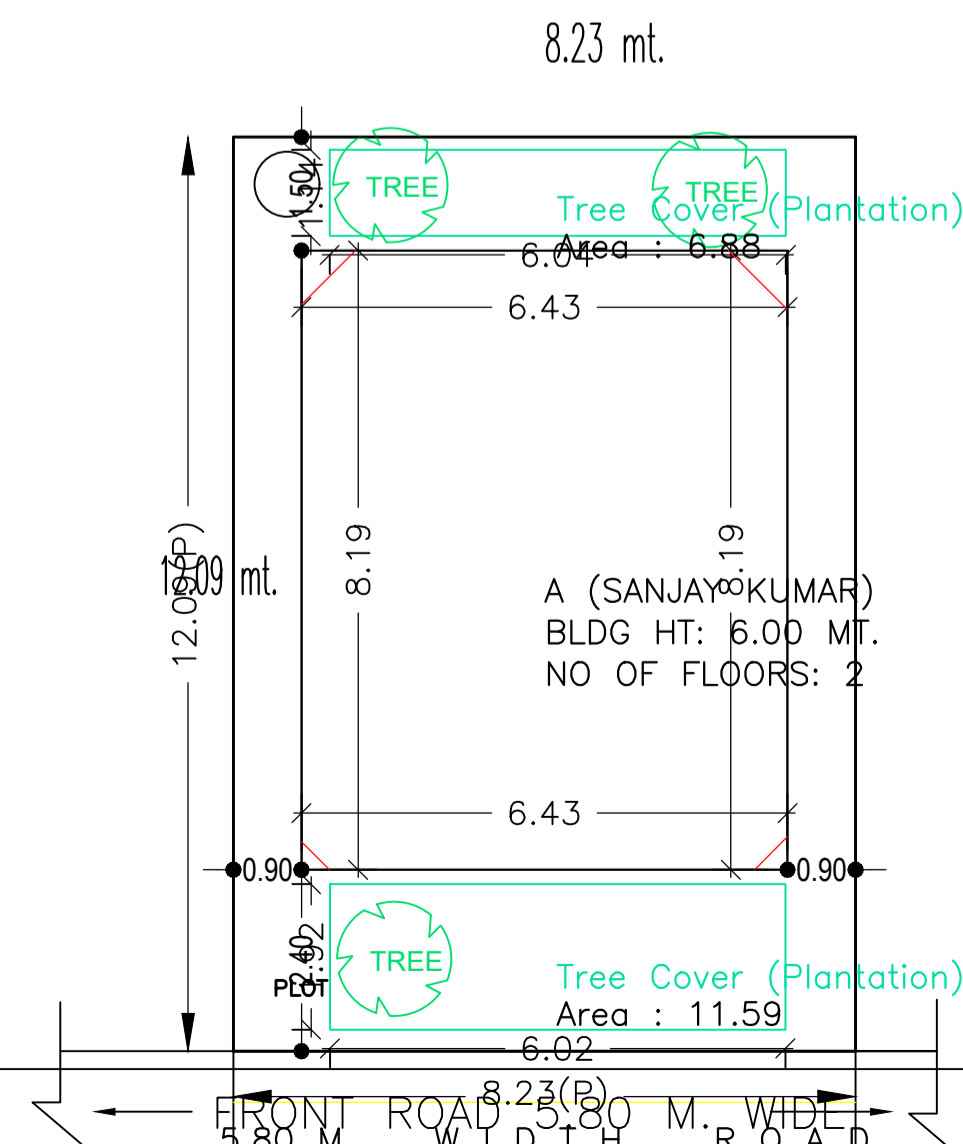

| LTP NAME AND SIGNATURE | STRUCTURAL ENG'S NAME AND SIGNATURE | BUILDER NAME AND SIGNATURE | DIGITAL SIGNATURE |
|--|-------------------------------------|----------------------------|-------------------|
| Chandrika Sharma MNAC/DFTMN/0017/2017 | | | |

Proposal Basic Information

| | |
|-------------------|------------------------------------|
| Proposal File No. | MNAC/BP/0002/W09/2019 |
| Owner Name | SANJAY KUMAR |
| Khata No | 303 |
| Plot No | 1790 |
| Village Name | Dimna |
| Use | Residential |
| SubUse | Bungalow/ Dwelling / Non Apartment |

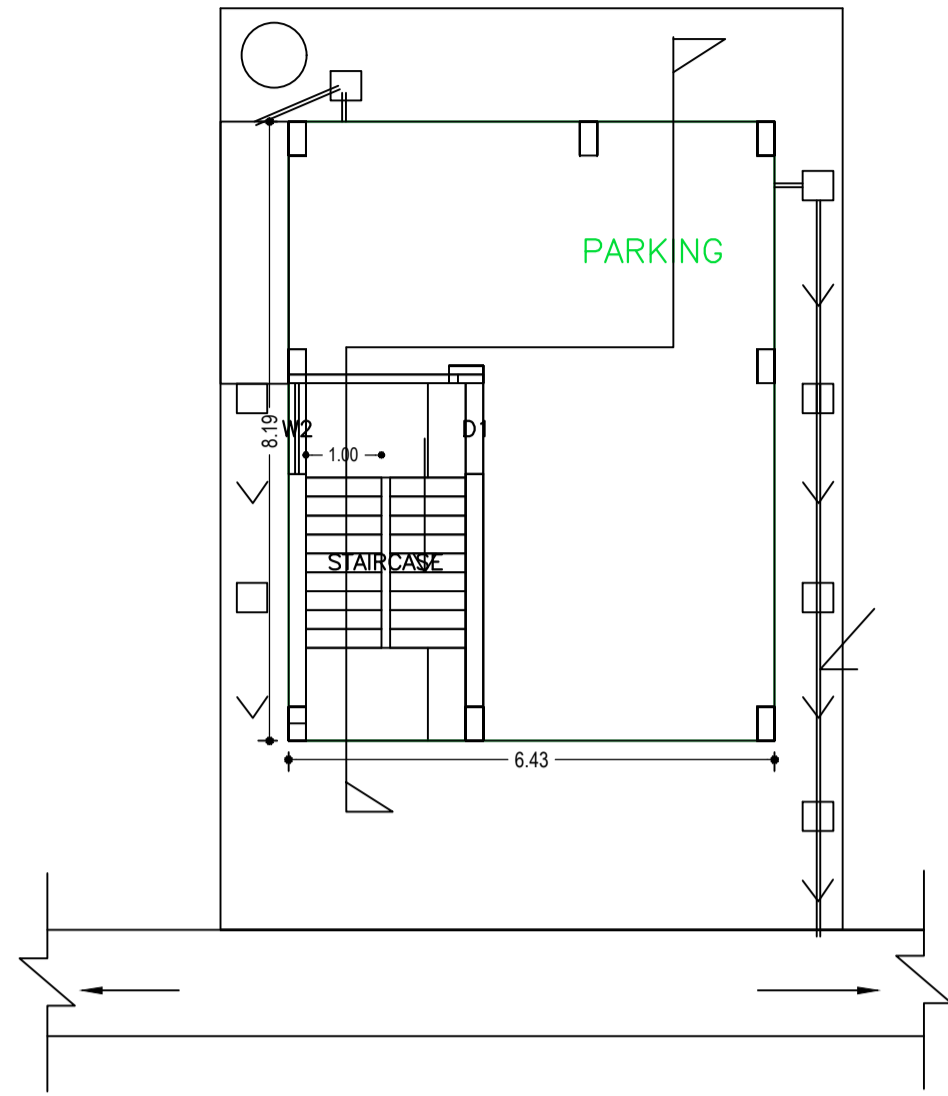

GROUND AND PARKING FLOOR PLAN
(SCALE 1:100)

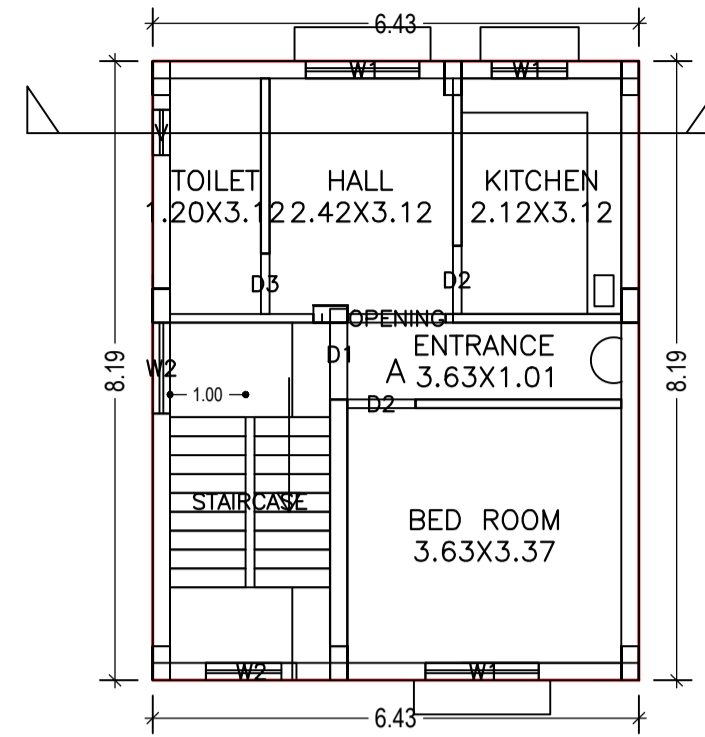

FIRST FLOOR PLAN
(Proposed)
(SCALE 1:100)

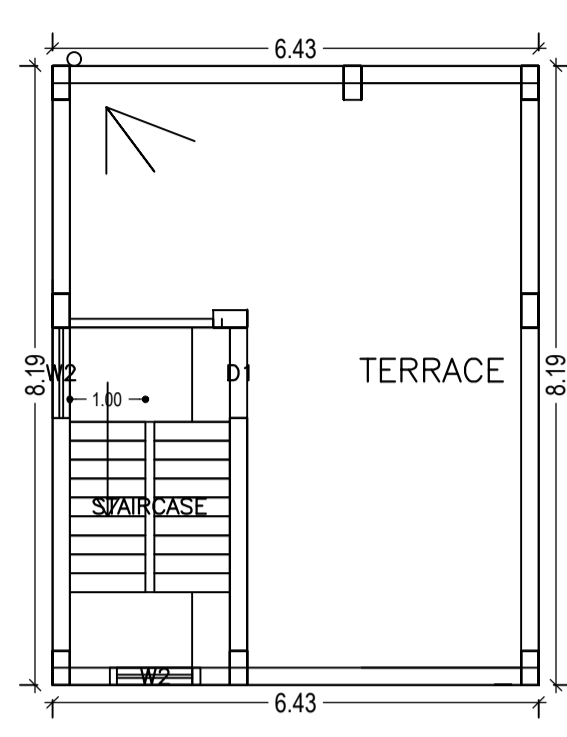

TERRACE FLOOR PLAN
(SCALE 1:100)

Building :A (SANJAY KUMAR)

| Floor Name | Total Built Up Area (Sq.mt.) | Deductions (Area in Sq.mt.) | | Proposed FAR Area (Sq.mt.) | | | Total Consumed Additional FAR Area (Sq.mt.) | Tnmt (No.) |
|----------------------------------|------------------------------|-----------------------------|--------------|----------------------------|--------------------------|-------------------------|---|------------|
| | | Parking | Resi. | Stair | Add Area In FAR (Sq.mt.) | Total FAR Area (Sq.mt.) | | |
| First Floor | 52.66 | 0.00 | 52.66 | 10.00 | 10.00 | 10.00 | 00 | |
| Terrace Floor | 0.00 | 0.00 | 0.00 | 0.00 | 0.00 | 0.00 | 00 | |
| Total : | 105.32 | 42.66 | 52.66 | 10.00 | 62.66 | 62.66 | 01 | |
| Total Number of Same Buildings : | 1 | | | | | | | |
| Total : | 105.32 | 42.66 | 52.66 | 10.00 | 62.66 | 62.66 | 01 | |

SCHEDULE OF DOOR:

| BUILDING NAME | NAME | LENGTH | HEIGHT | NOS |
|------------------|---------|--------|--------|-----|
| A (SANJAY KUMAR) | D3 | 0.80 | 2.10 | 01 |
| A (SANJAY KUMAR) | D2 | 0.90 | 2.10 | 02 |
| A (SANJAY KUMAR) | D1 | 1.20 | 2.10 | 01 |
| A (SANJAY KUMAR) | OPENING | 1.30 | 2.10 | 01 |

UnitBUA Table for Building :A (SANJAY KUMAR)

| FLOOR | Name | UnitBUA Type | UnitBUA Area | Carpet Area | No. of Rooms | No. of Tenement |
|------------------|------|--------------|--------------|-------------|--------------|-----------------|
| FIRST FLOOR PLAN | A | FLAT | 52.66 | 50.83 | 5 | 1 |
| Total: | - | - | 52.66 | 50.83 | 5 | 1 |

SCHEDULE OF WINDOW/VENTILATION:

| BUILDING NAME | NAME | LENGTH | HEIGHT | NOS |
|------------------|------|--------|--------|-----|
| A (SANJAY KUMAR) | V | 0.60 | 0.60 | 01 |
| A (SANJAY KUMAR) | W1 | 1.00 | 1.20 | 01 |
| A (SANJAY KUMAR) | W1 | 1.20 | 1.20 | 05 |
| A (SANJAY KUMAR) | W1 | 1.50 | 1.20 | 02 |

| LTP NAME AND SIGNATURE | STRUCTURAL ENG'S NAME AND SIGNATURE | BUILDER NAME AND SIGNATURE | DIGITAL SIGNATURE |
|--|-------------------------------------|----------------------------|-------------------|
| Chandrika Sharma MNAC/DFTMN/0017/2017 | | | |

| Proposal Basic Information | |
|----------------------------|------------------------------------|
| Proposal File No. | MNAC/BI/0002/W09/2019 |
| Owner Name | SANJAY KUMAR |
| Khata No | 303 |
| Plot No | 1790 |
| Village Name | Dimna |
| Use | Residential |
| SubUse | Bungalow/ Dwelling / Non Apartment |

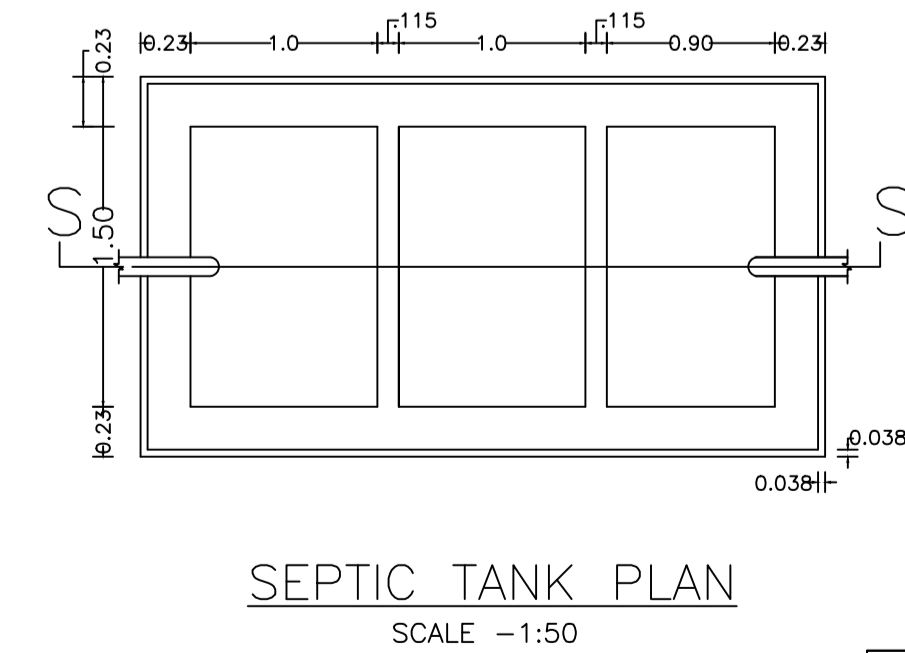
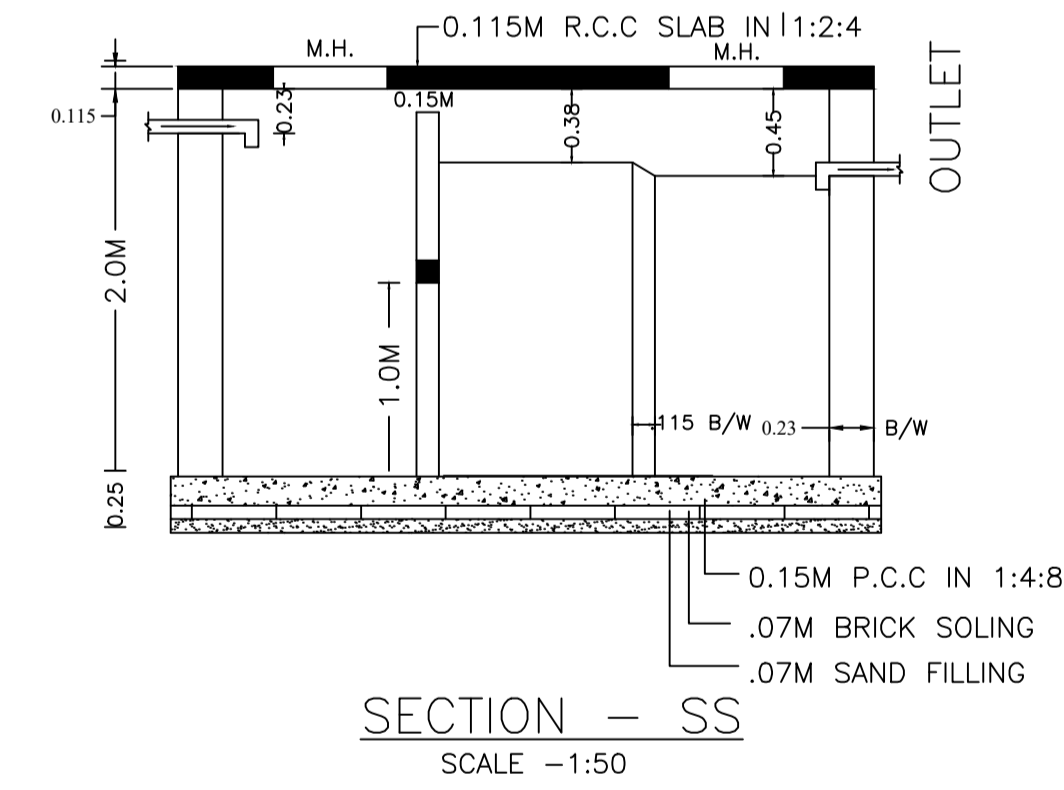
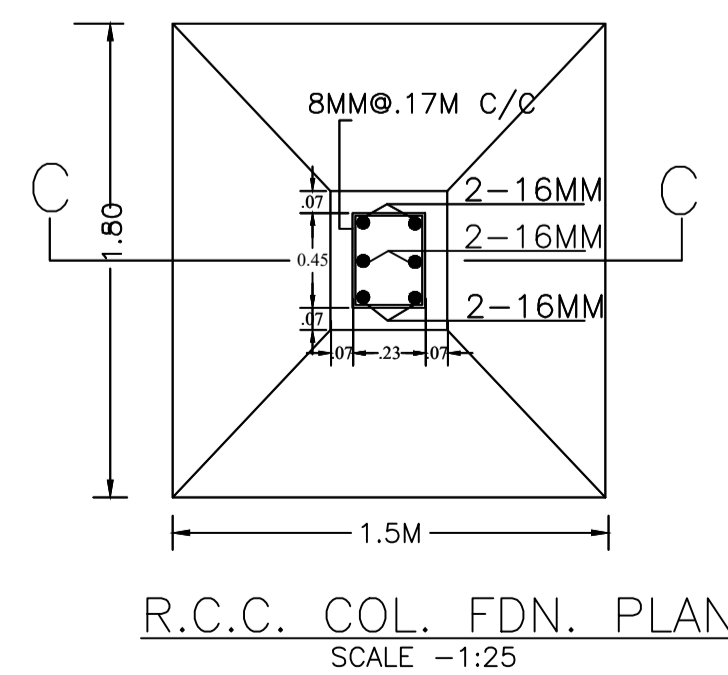
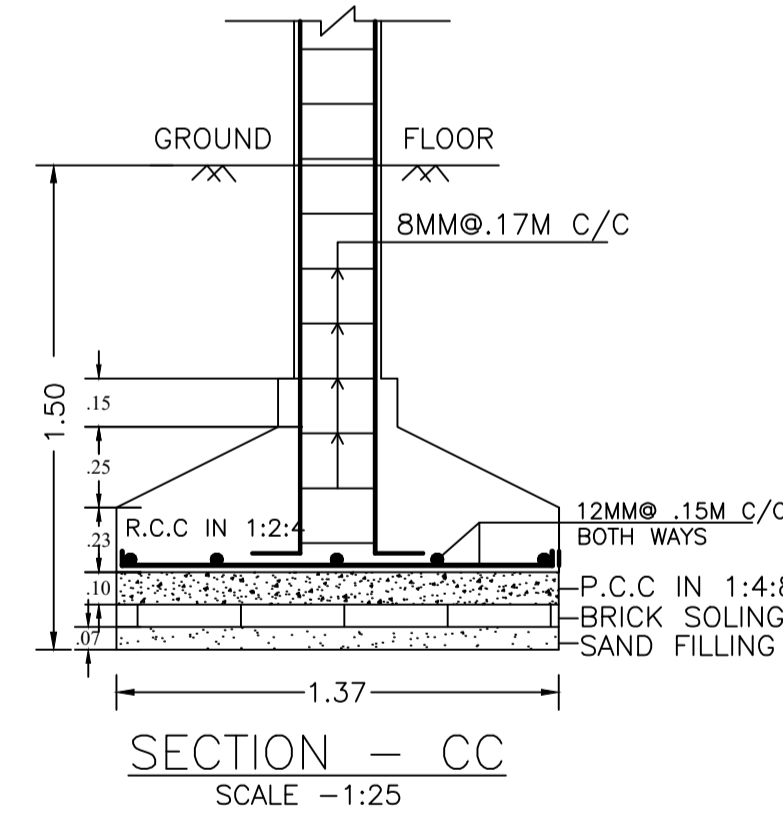
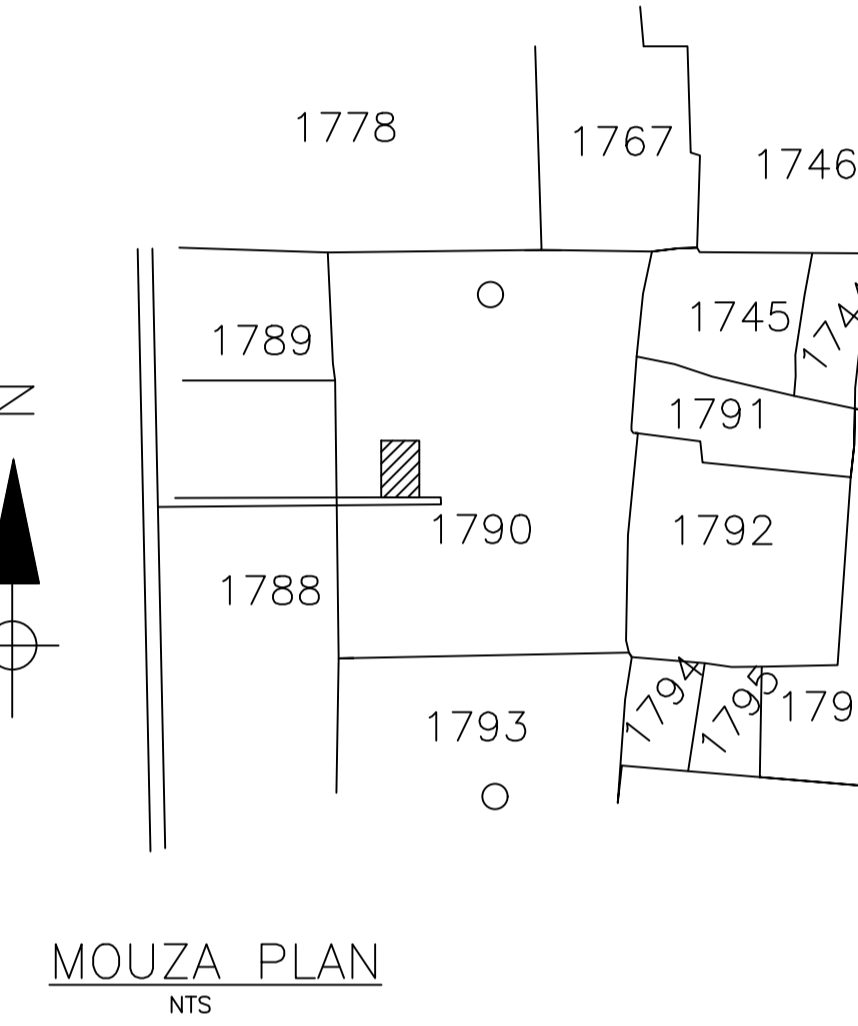
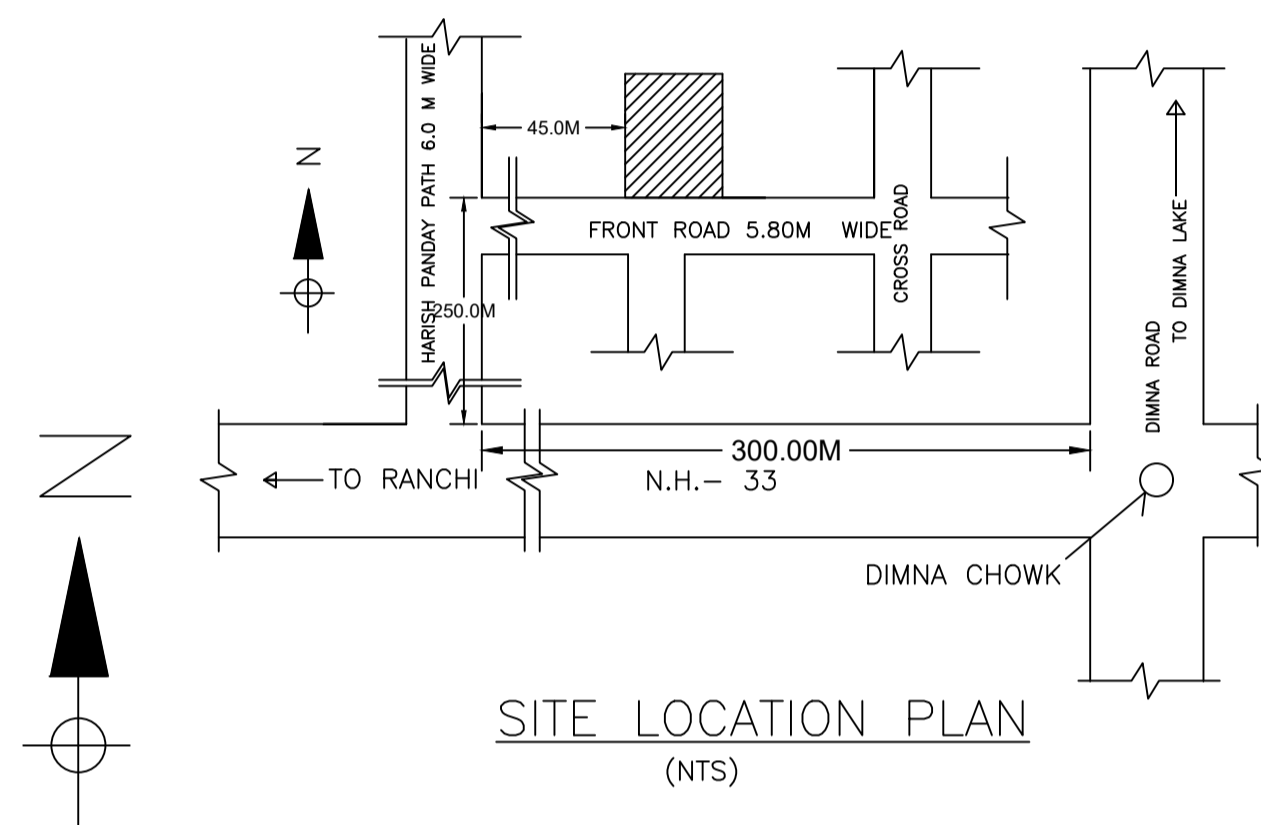
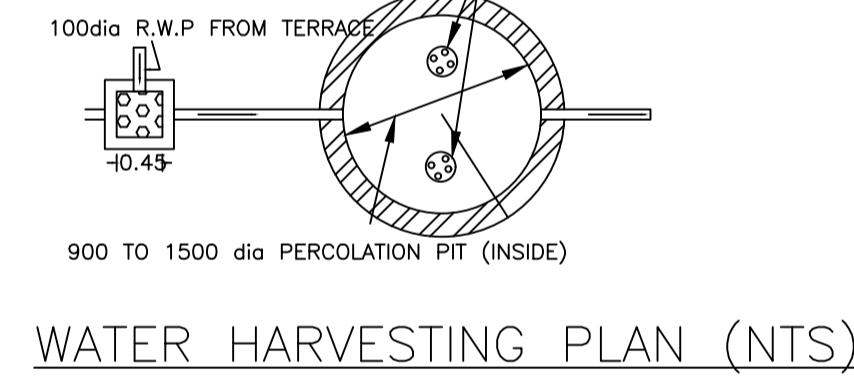
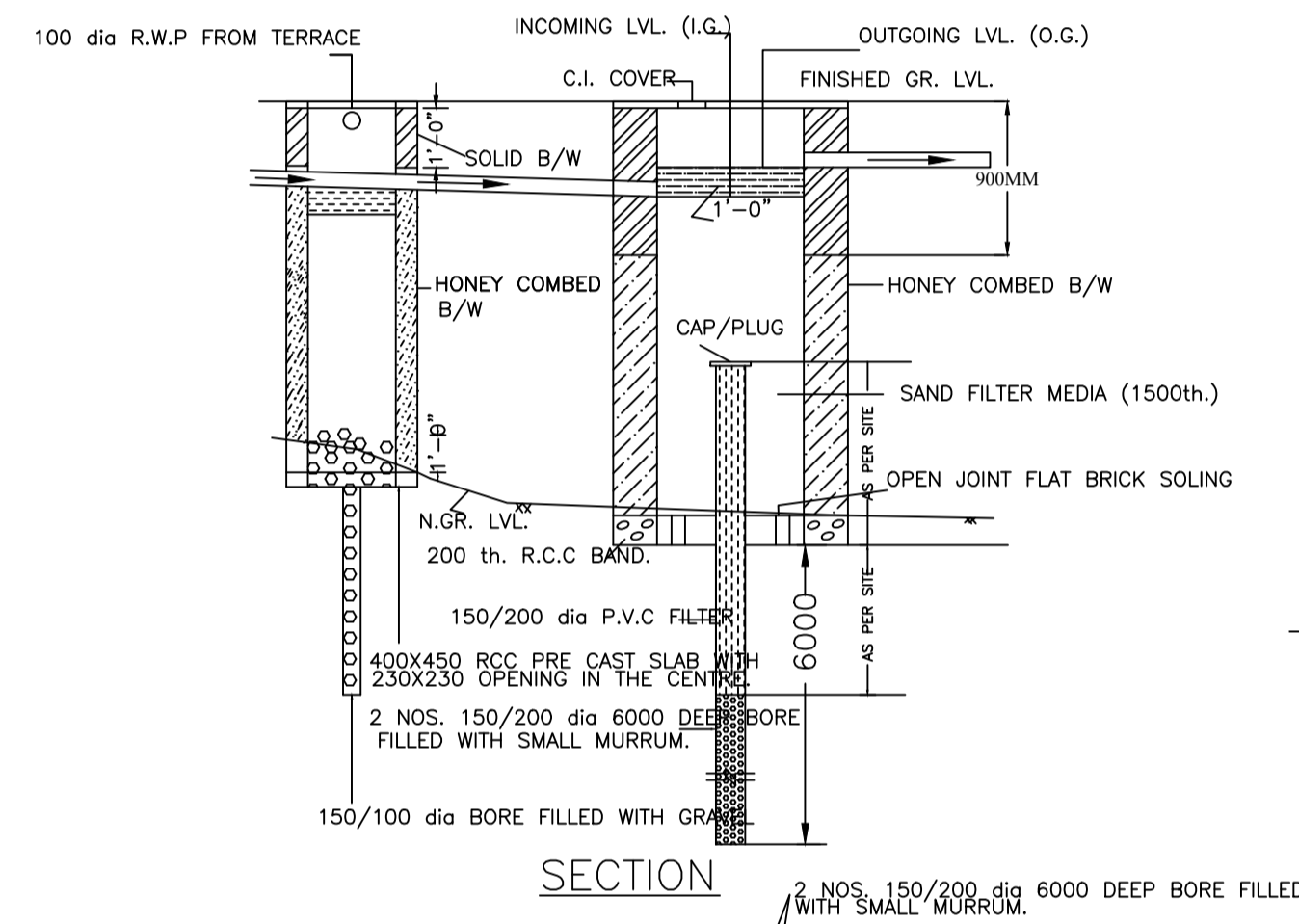
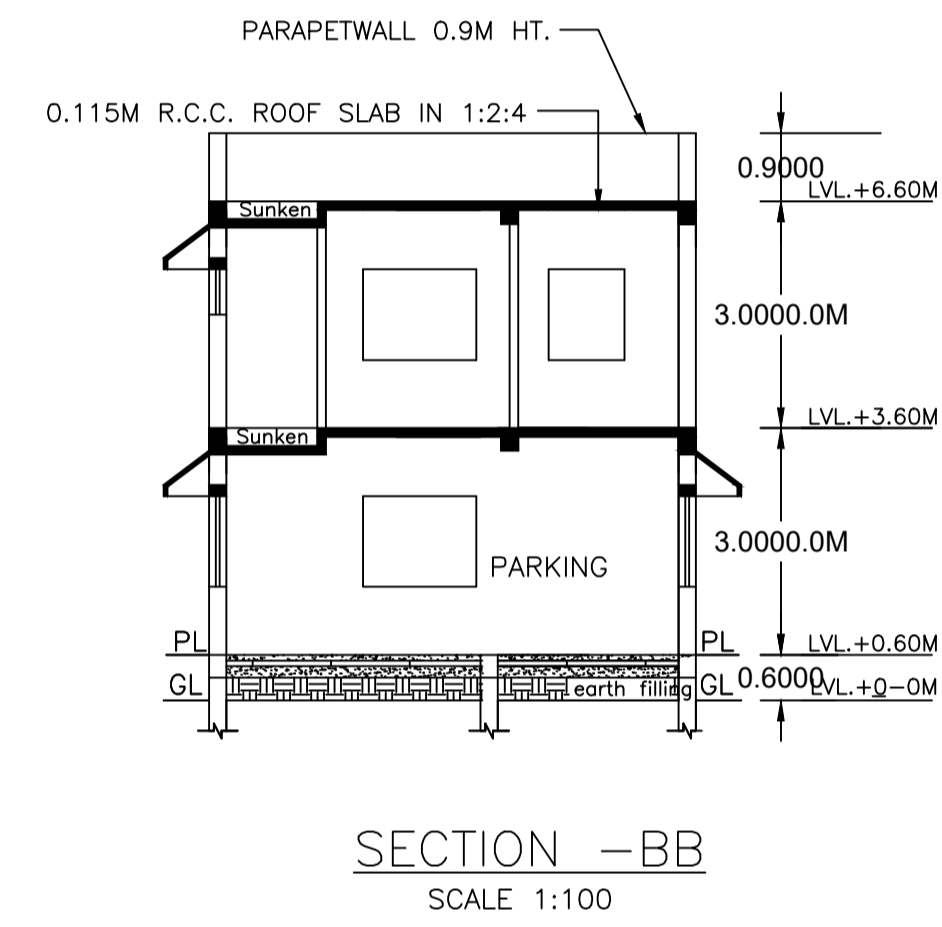
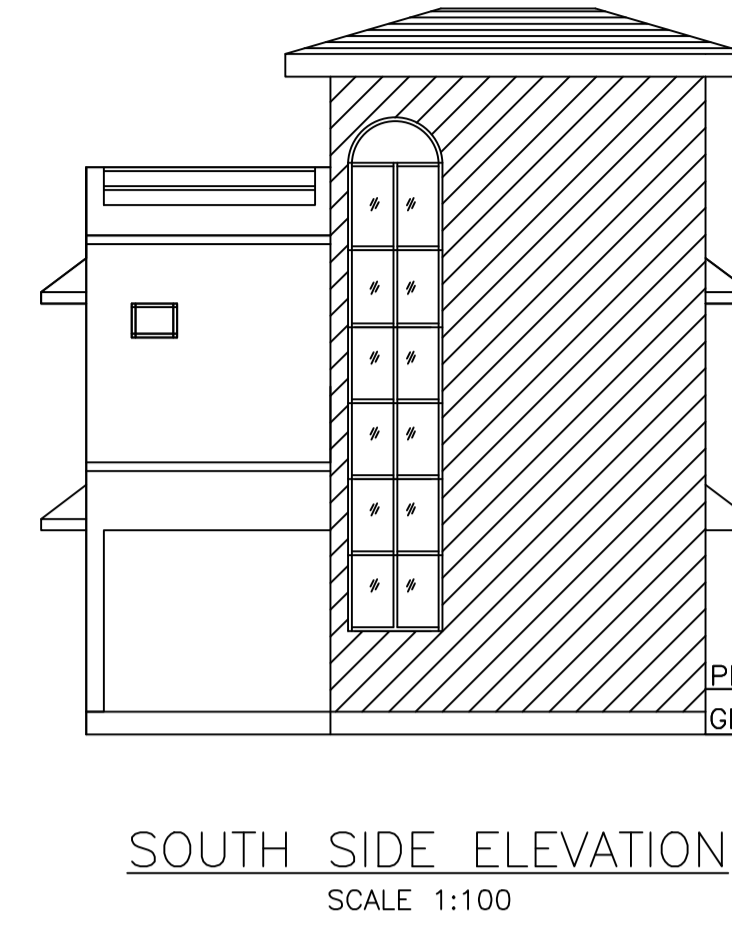
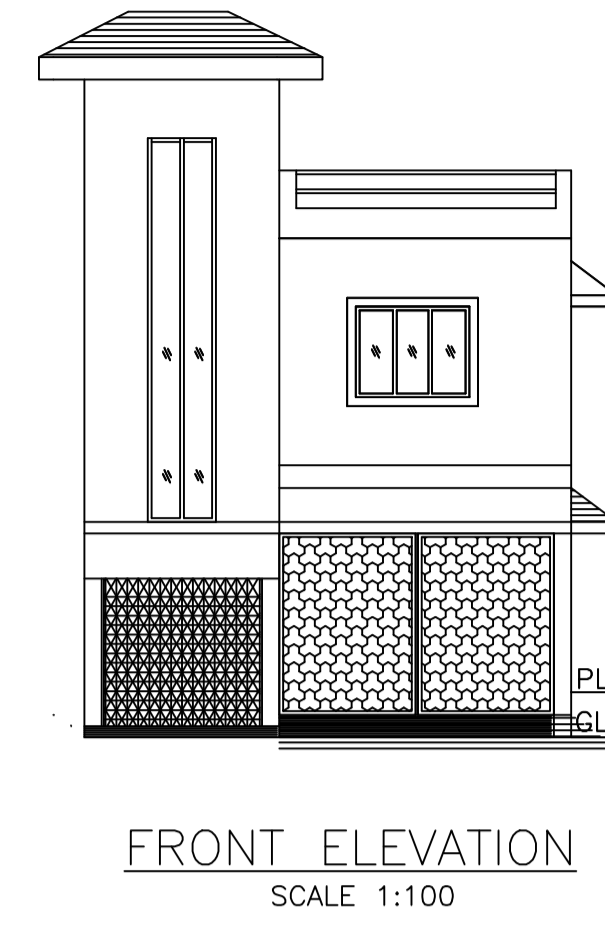
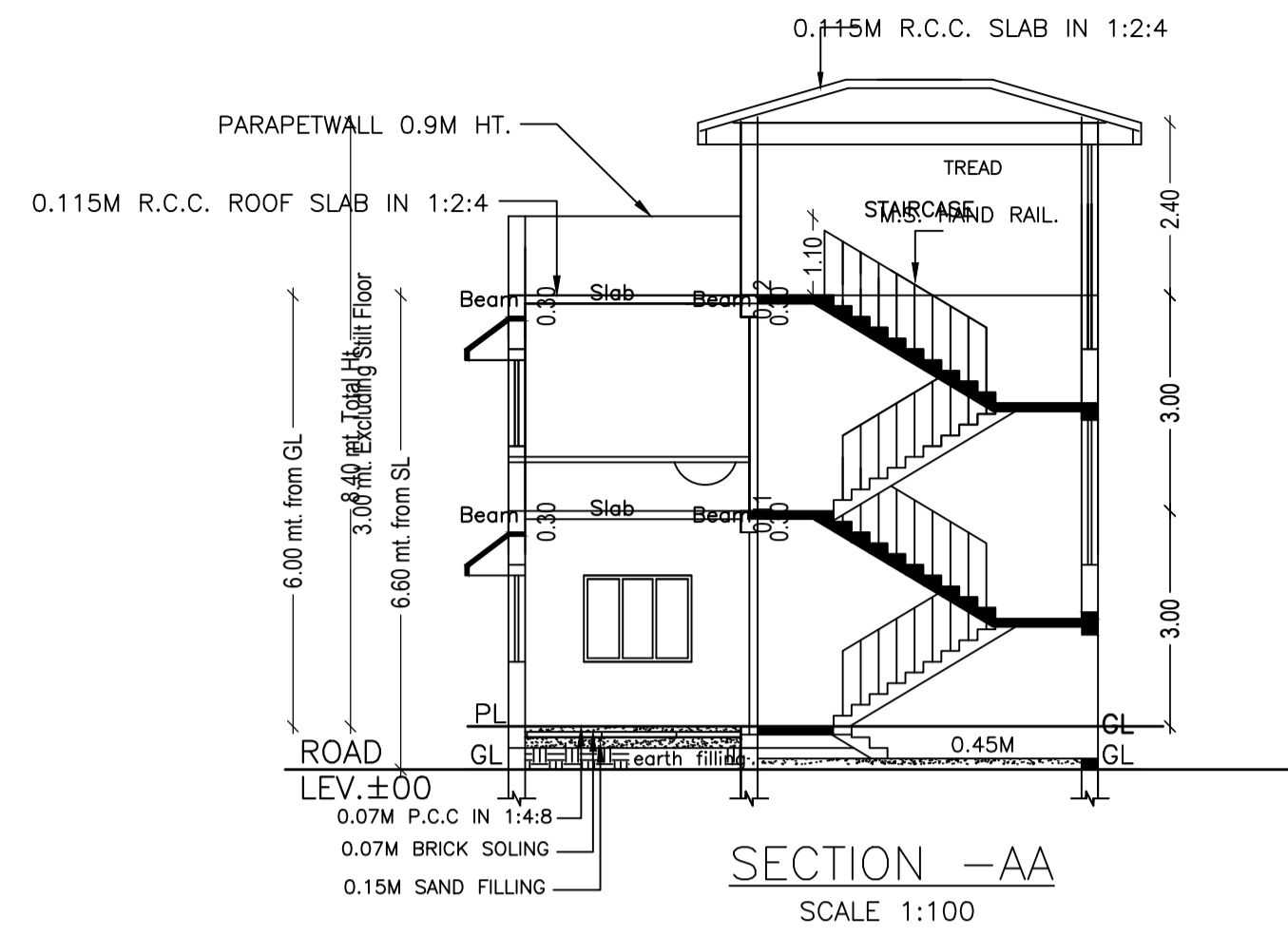

| LTP NAME AND SIGNATURE | STRUCTURAL ENG'S NAME AND SIGNATURE | BUILDER NAME AND SIGNATURE | DIGITAL SIGNATURE |
|--|-------------------------------------|----------------------------|-------------------|
| Chandrika Sharma MNAC/DFTMN/0017/2017 | | | |