

Project Title - MUSLIM FUND

AREA STATEMENT: MARGO NAG	VERSION NO. 1.0.17
PROJECT DETAIL:	VERSION DATE: 01/01/2019
Township No. :-	Plot Use: Residential
Region: JHARKHAND URBAN LOCAL BODIES	Plot Subtype: Bungalow Dwelling / Non Apartment
District: EAST SINGHBHUM	Land Use Zone: NA
Application Type: General Proposal	Abutting Road Width: -
Project Type: Building Permission	Plot No.:
Nature of Development: New	Reference Survey No/Survey No.:-
Location: Old Area	Thana No.:-
Sub Location: NA	Holding No.:-
Wing/Marginal Name: -	Khata No.:-
Ward No.:-	North:-
Road/Street: -	South:-
	East:-
	West:-

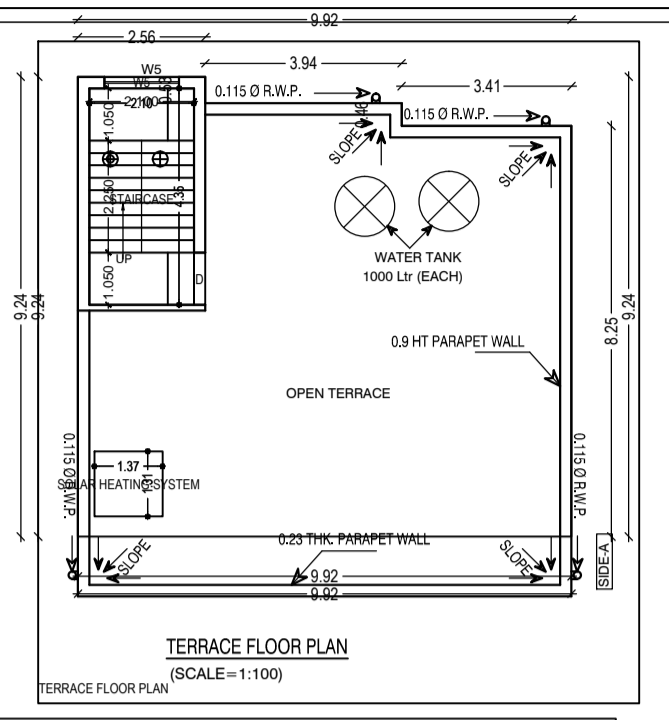
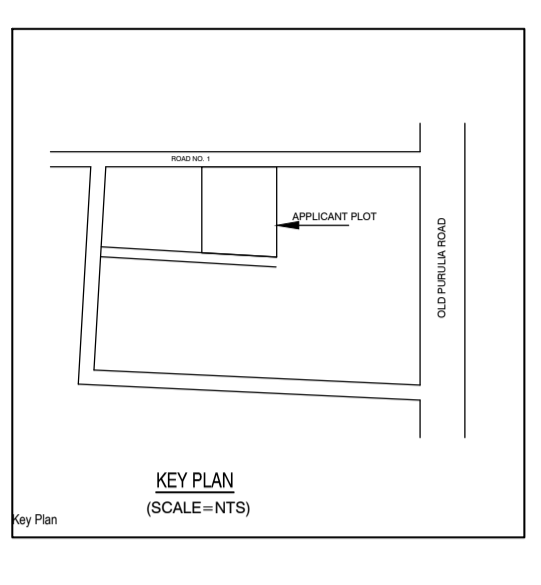
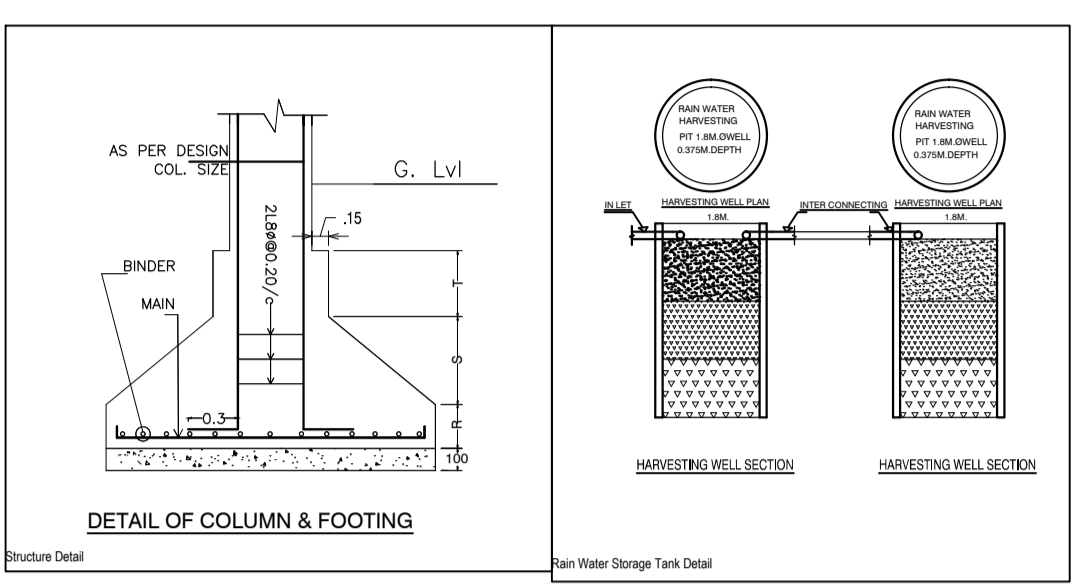

Sl.No.	LAND DETAIL	EXISTING	PROPOSED	TOTAL AREA IN Sqm
1.	PLOT AREA	NIL	166.99 Sqm	166.99 Sqm
2.	GROUND COVERAGE	NIL	86.19 Sqm	86.19 Sqm
FLOOR DETAIL				
AREA IN Sqm				
3.	GROUND FLOOR	NIL	86.19 Sqm	86.19 Sqm
4.	FIRST FLOOR	NIL	86.19 Sqm	86.19 Sqm
5.	SECOND FLOOR	NIL	98.09 Sqm	98.09 Sqm
6.	TOTAL			270.47 Sqm
7.	GROUND COVERAGE		86.19 / 166.99 x 100 = 51.61 %	< 70 % OK
8.	F.A.R. DETAIL		270.47 / 166.99 = 1.62	

Sl.No.	TYPE	LENGTH	HEIGHT	SL. DIST.	WIND. DIST.	DOOR/OPS
1.	D	1.00m	2.10m	0.2m	2.1m	FULLY GLAZED DOOR
2.	OT	0.80m	2.10m	0.2m	2.1m	FULLY GLAZED DOOR
3.	OS	0.70m	0.70m	0.2m	2.1m	FULLY GLAZED DOOR
4.	WV	1.50m	1.20m	0.90m	2.1m	FULLY GLAZED WINDOW
5.	WV	1.20m	1.20m	0.90m	2.1m	FULLY GLAZED WINDOW
6.	WV	0.80m	0.80m	0.2m	2.1m	FULLY GLAZED WINDOW
7.	WV	0.80m	0.80m	0.2m	2.1m	FULLY GLAZED WINDOW

NOTE:
 1. FOUNDATION & R.C.C. AS PER STRUCTURAL ENGG. SPECIFICATION
 2. ALL DIMENSIONS IN MM.
 3. DRAWING NOT TO BE SCALED

FLOOR AREA STATEMENT:
 Net Plot Area (Gross Plot Area) (A-Deductions) 166.99
 Deduction from Gross Plot Area (A-Deductions) 80.80
 Net Plot Area (Net Plot Area) (A-Deductions) 86.19
 Deduction from Net Plot Area (A-Deductions) 8.00
 Net Floor Area (Net Floor Area) (A-Deductions) 78.19
 Deduction from Net Floor Area (A-Deductions) 1.00
 Net Floor Area (Net Floor Area) (A-Deductions) 77.19

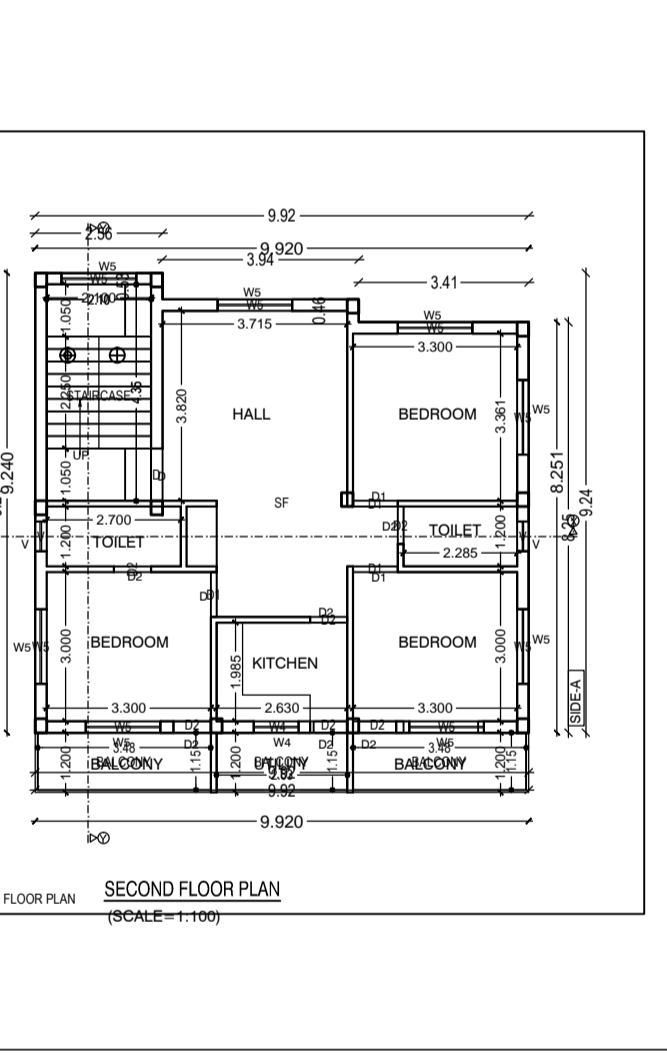
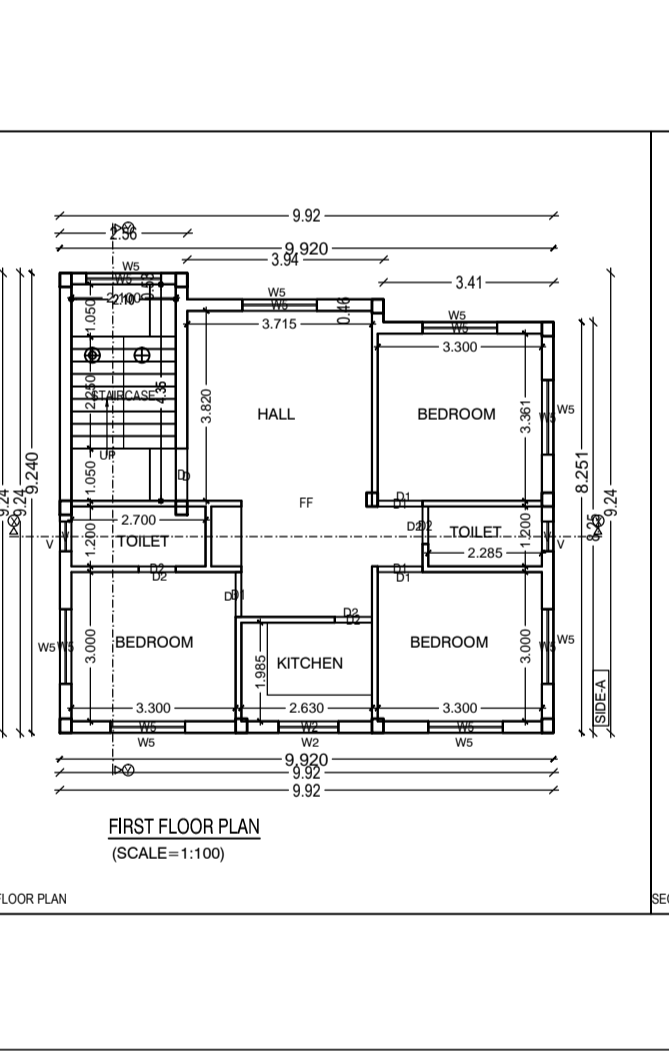
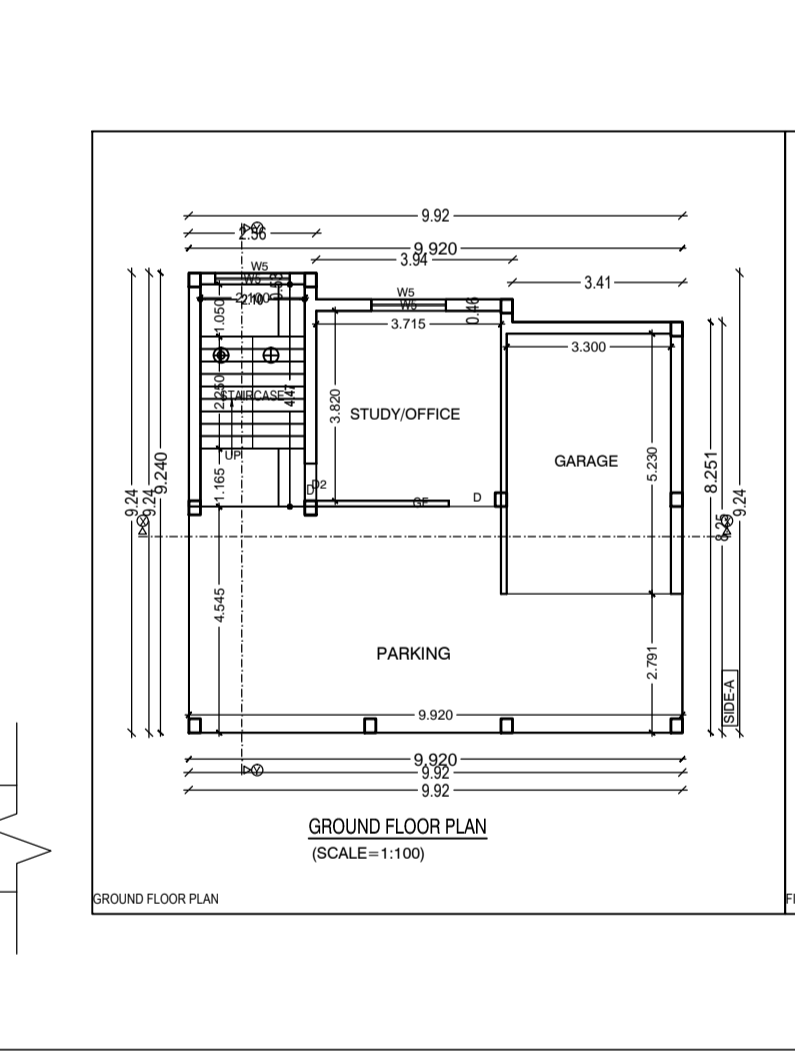
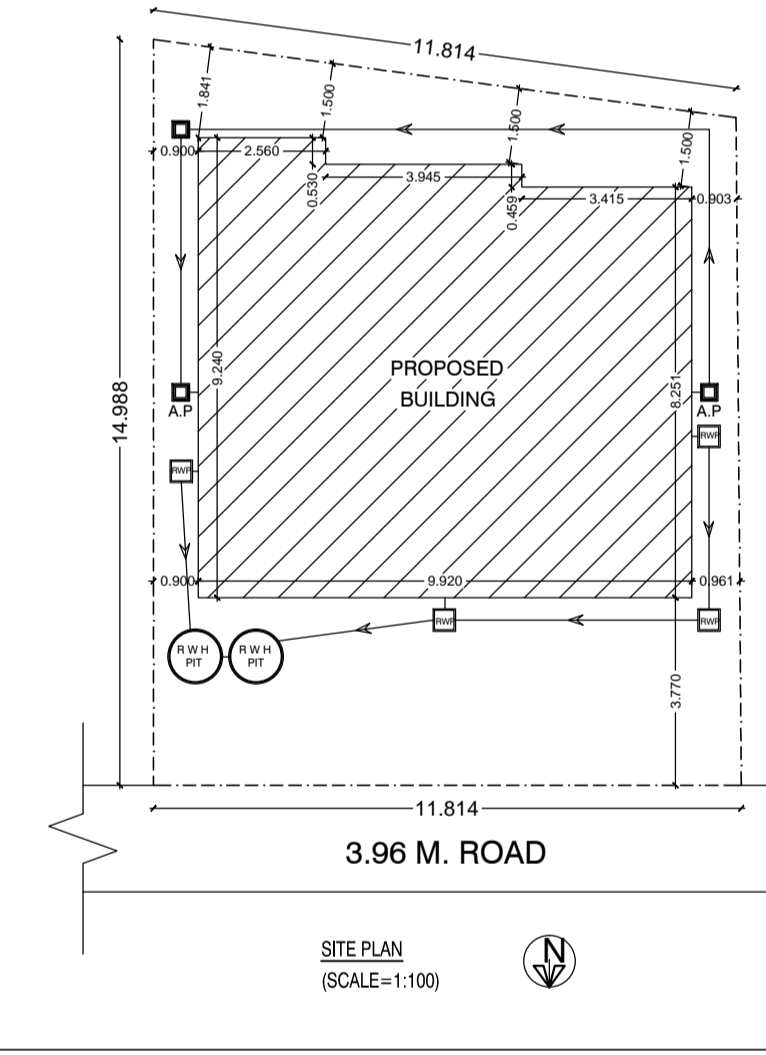
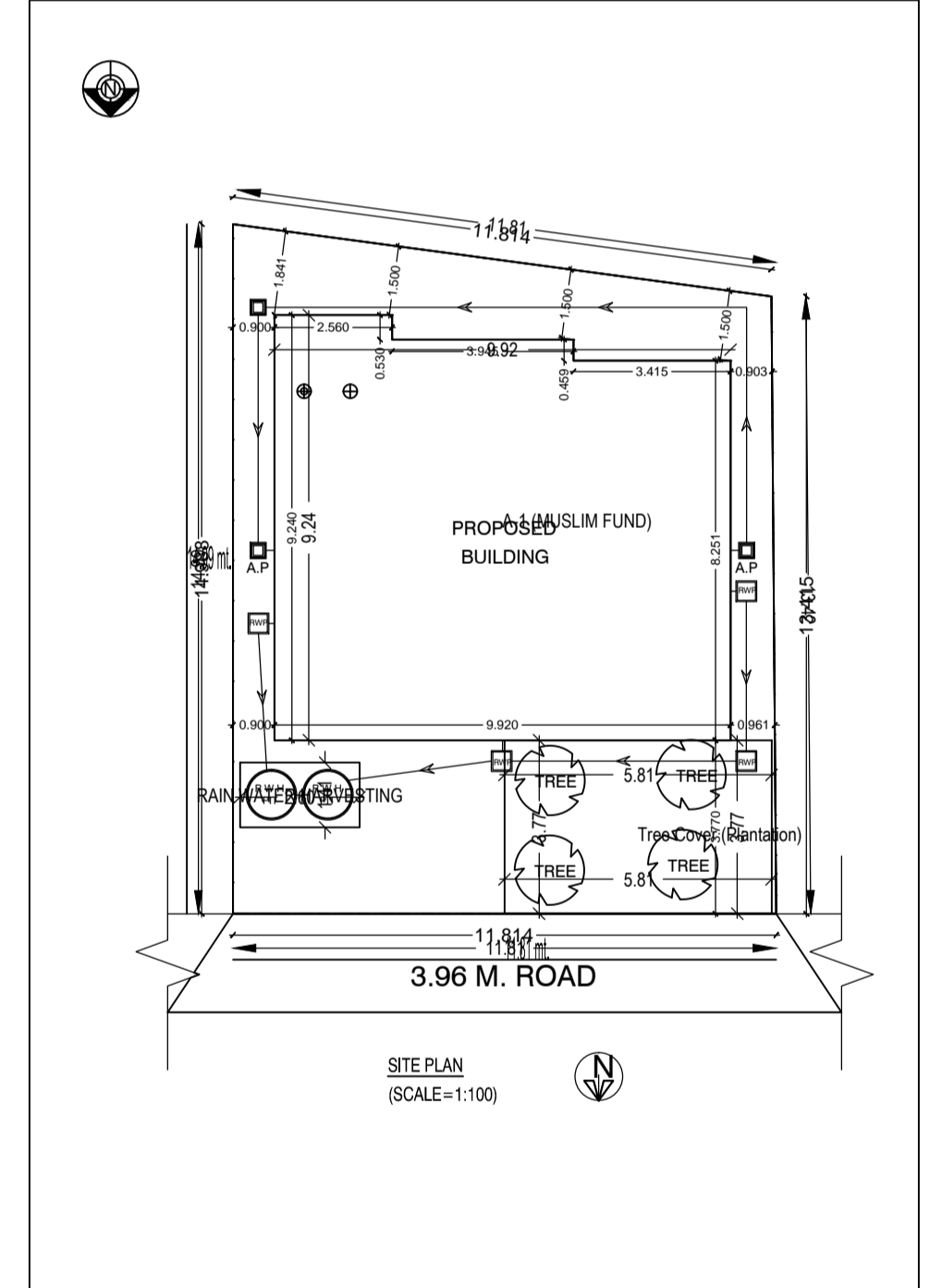
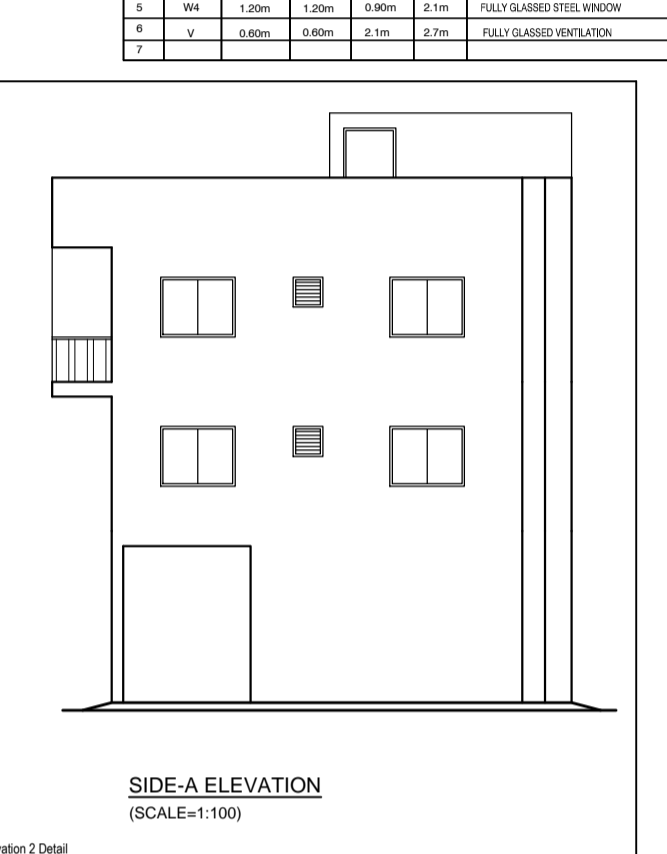
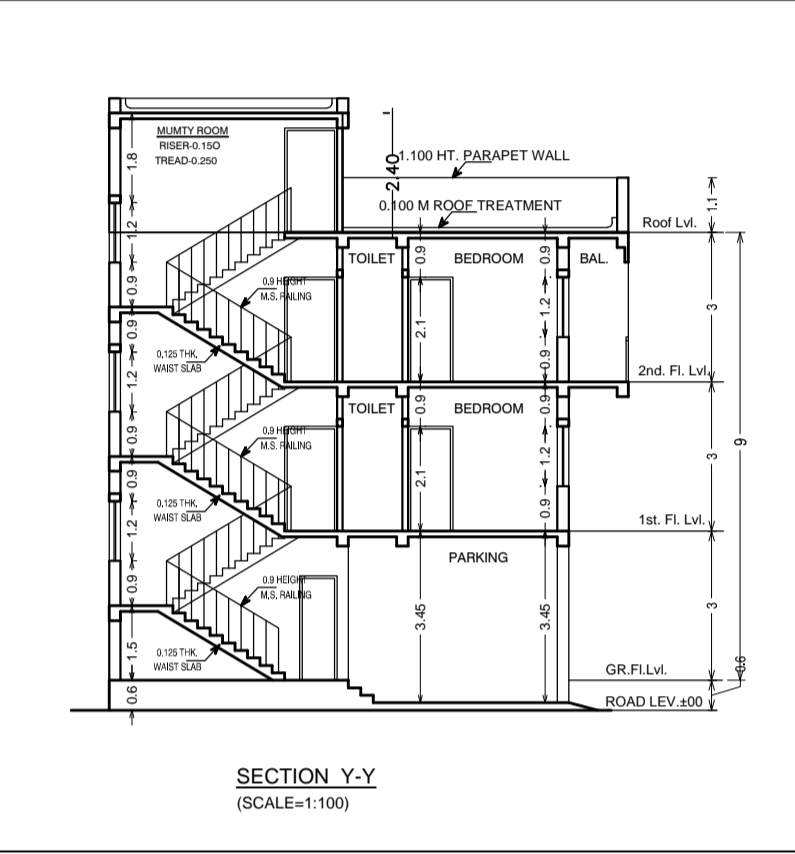
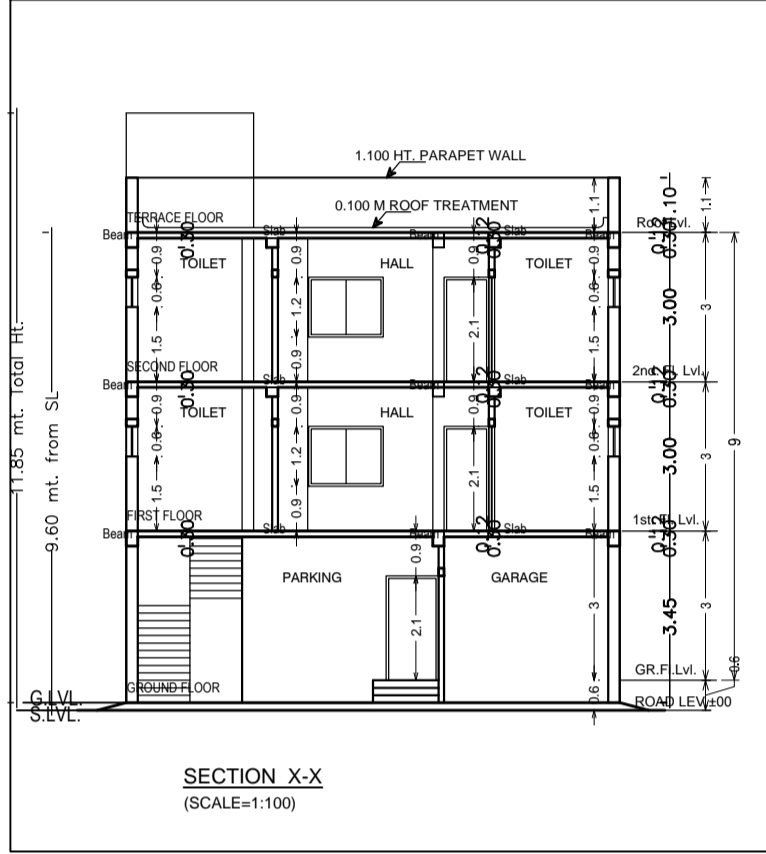

APPROVED:-

SPL OFFICER, J.N.A.C.

OWNER / POAH

Signature of Applicant:-

GENERAL SPECIFICATION :-
 FOUNDATION: R.C.C. COLUMN FOOTING & COLUMN AS PER STRUCTURAL DESIGN.
 SUPER STRUCTURE: R.C.C. COLUMN & BEAM AS PER STR. DESIGN. 10.00M THK. EXT. WALL & 10.00M THK. PARTITION WALL IN CEMENT MORTAR.
 R.C.C. ROOF SLAB AS PER STRUCTURAL DESIGN.
 FLOOR: Mosaic Cast in situ Ceramic Tiles Dado in Toilet.
 INTERNAL FINISH: CEMENT PLASTER WITH POP @ 0.0.0.
 SANITARY: VITROUS CHINA CLAY SANITARY WARE G.I. PIPE WATER SUPPLY.
 S.P.C.P.P. FOR SEWAGE DISPOSAL.
 DOORS & WINDOW: AS PER SCHEDULE.
 ELECTRICAL: COPPER WIRE WITH P.V.C. CONDUIT.

PROPOSED RESIDENTIAL BUILDING PLAN OF MR. MAHMOOD ALAM ANSARI SECRETARY OF MUSLIM FUND PLOT NO.- 3531, KHATA NO.- 162, MOUZA- PARDIH, WARD NO.- 08, THANA- MARGO, THANA NO.- 1641, DISTRICT-EAST SINGHBHUM, JHARKHAND

L.K. SUMAN
 Reg. No- C-20/2002

L.K. SUMAN
 Reg. No- C-20/002
 J.N.A.C.
 Plot: 1, Second Floor, Street: Taka, Centre: Street: Jamshepur

Reg No- C-20/2002 M-8835131161

AREA STATEMENT:
 Net Plot Area (Gross Plot Area) (A-Deductions) 166.99
 Deduction from Gross Plot Area (A-Deductions) 80.80
 Net Plot Area (Net Plot Area) (A-Deductions) 86.19
 Deduction from Net Plot Area (A-Deductions) 8.00
 Net Floor Area (Net Floor Area) (A-Deductions) 78.19
 Deduction from Net Floor Area (A-Deductions) 1.00
 Net Floor Area (Net Floor Area) (A-Deductions) 77.19

COLOR INDEX

Color Index:
 MARGIN DETAIL:
 Road Name: 3.96 M. ROAD
 Front Margin: 3.77
 Rear Margin: 1.50
 Side1 Margin: 0.90
 Side2 Margin: 0.90

FAR & Terment Details (Table 4c-1)

Building	No. of Same Bldg	Total Built Up Area (Sq.mt)	Deductions (Area in Sq.mt)	Proposed FAR Area (Sq.mt)	Total FAR Area (Sq.mt)	Tent (%)
A MUSLIM FUND	1	269.59	5.51	264.08	264.08	03
Grand Total	1	269.59	5.51	264.08	264.08	03

Building 'A' (MUSLIM FUND)

Floor Name	Total Built Up Area (Sq.mt)	Deductions (Area in Sq.mt)	Proposed FAR Area (Sq.mt)	Total FAR Area (Sq.mt)	Tent (%)
Ground Floor	86.19	0.00	86.19	86.19	01
First Floor	86.19	0.00	86.19	86.19	01
Second Floor	97.21	5.51	91.70	91.70	01
Terrace Floor	0.00	0.00	0.00	0.00	00
Total	269.59	5.51	264.08	264.08	03

SCHEDULE OF JOINERY:

BUILDING NAME	NAME	LENGTH	HEIGHT	NOS
A MUSLIM FUND	OS	0.70	2.10	08
A MUSLIM FUND	O1	0.90	2.10	08
A MUSLIM FUND	D	1.00	2.10	04
Total	-	-	-	19

SCHEDULE OF JOINERY:

BUILDING NAME	NAME	LENGTH	HEIGHT	NOS
A MUSLIM FUND	V	0.60	1.00	04
A MUSLIM FUND	WV	0.90	1.20	01
A MUSLIM FUND	WV	1.20	1.20	01
A MUSLIM FUND	WV	1.50	1.20	19
Total	-	-	-	28

Balcony Calculations Table

FLOOR	SIZE	AREA	TOTAL AREA
SECOND FLOOR PLAN	1.15 X 2.63 X 1 X 1	3.02	11.02
Total	1.15 X 3.42 X 3 X 1	8.00	11.02

UnBUA Table for Building - A (MUSLIM FUND)

FLOOR	Name	UnBUA Type	UnBUA Area	Carpet Area	No. of Rooms	No. of Tenement
GROUND FLOOR PLAN	GF	FLAT	86.19	82.37	1	1
FIRST FLOOR PLAN	FF	FLAT	86.19	77.31	7	7
SECOND FLOOR PLAN	SF	FLAT	91.70	82.82	7	7
Total	-	-	264.08	242.50	15	3