

Project Title - AZHARUDDIN DANISH

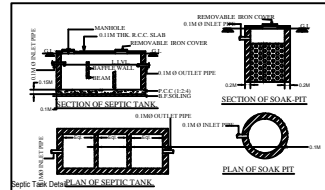

AREA CALCULATION

TOTAL PLOT AREA = 136.98 SQMT
COVERED AREA = 93.16 SQMT

GROUND FLOOR BUILTUP AREA = 51.16 SQMT
1ST FLOOR BUILTUP AREA = 56.44 SQMT
2ND FLOOR BUILTUP AREA = 56.44 SQMT
TOTAL BUILTUP AREA = 264.04 SQMT

% OF COVERAGE = $93.16 \times 100 / 136.98 = 68.01\%$
F.A.R. = $264.04 / 136.98 = 2.09$

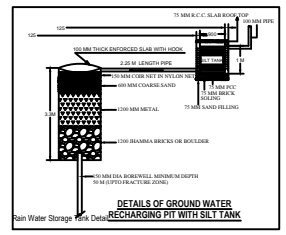
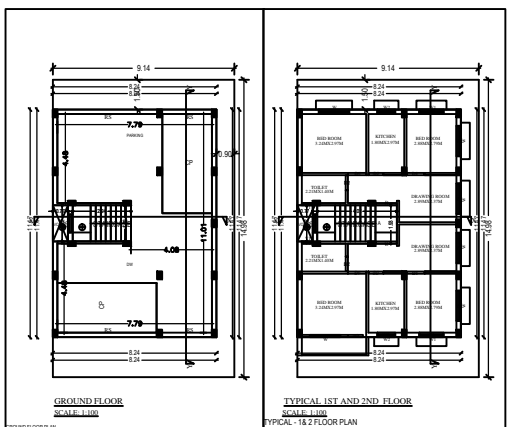
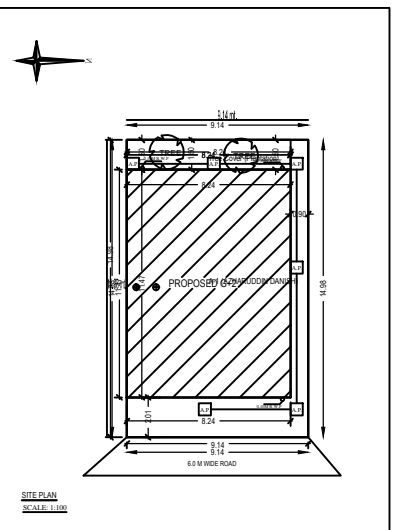
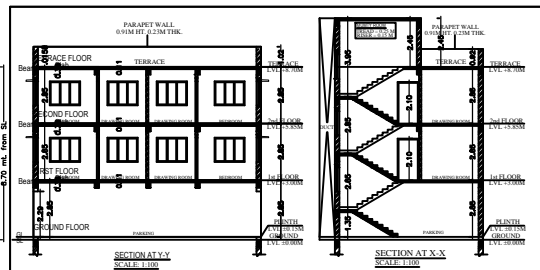
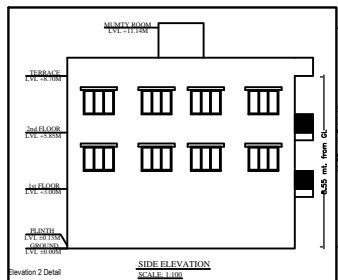
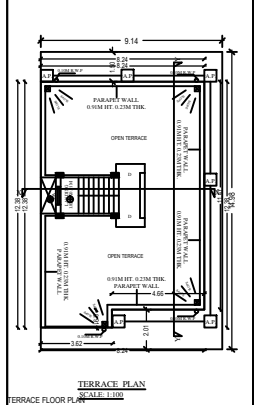
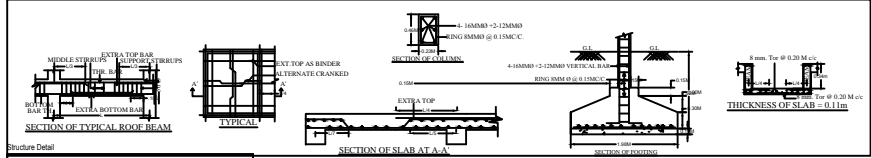
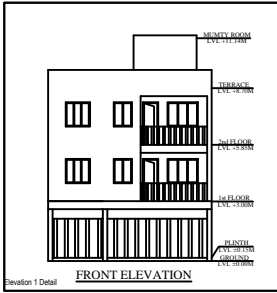
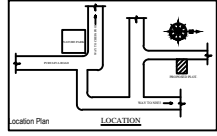

SCHEDULE OF OPENINGS

MKD.	SIZE	DESCRIPTION
RS	5.04M X 2.13M	Panmelled single shutter door.
RS	2.52M X 2.13M	Panmelled single shutter door.
D	1.07M X 2.13M	Panmelled single shutter door.
D1	0.92M X 2.13M	Panmelled single shutter door.
D2	0.76M X 2.13M	Panmelled single shutter door.
W	1.52M X 1.22M	Glazed steel framed window 3. shutt.
W1	1.22M X 1.22M	Glazed steel framed window 3. shutt.
W2	0.91M X 1.22M	Glazed steel framed window 3. shutt.
V	0.54M X 0.61M	Ventilator

REVISION DETAIL

NO.	DESCRIPTION	DATE
1	ISSUED FOR PERMIT	10/10/2023

AREA SCHEDULE

NO.	DESCRIPTION	AREA (SQ.M)
1	TOTAL PLOT AREA	136.98
2	COVERED AREA	93.16
3	OPEN AREA	43.82
4	TOTAL BUILTUP AREA	264.04

COLOR INDEX

NO.	DESCRIPTION	COLOR
1	EXISTING CONCRETE	Grey
2	PROPOSED CONCRETE	Light Grey
3	EXISTING PLASTER	White
4	PROPOSED PLASTER	Light Grey

PARKING CALCULATION

NO.	DESCRIPTION	AREA (SQ.M)
1	TOTAL PARKING AREA	100.00
2	REQUIRED PARKING AREA	100.00

MARGIN DETAIL

NO.	DESCRIPTION	WIDTH (M)
1	FRONT MARGIN	2.00
2	REAR MARGIN	2.00
3	SIDE MARGIN	2.00

AR & Tenement Details (Table 4c-1)

NO.	DESCRIPTION	AREA (SQ.M)	PERCENTAGE (%)
1	TOTAL PLOT AREA	136.98	100.00
2	COVERED AREA	93.16	68.01
3	OPEN AREA	43.82	31.99

(AZHARUDDIN DANISH)

Building A (AZHARUDDIN DANISH)

Floor Name	Use	Total Built Up Area (Sq.M)	Net Area (Sq.M)	Net Area %	Total F.A.R.	Use (%)
GROUND FLOOR	RESIDENTIAL	51.16	51.16	37.41	1.00	100.00
1ST FLOOR	RESIDENTIAL	56.44	56.44	40.85	1.00	100.00
2ND FLOOR	RESIDENTIAL	56.44	56.44	40.85	1.00	100.00
TOTAL		164.04	164.04	119.11	3.00	100.00

SCHEDULE OF JOINERY

NO.	DESCRIPTION	SIZE	HEIGHT	QTY
1	SHUTTER DOOR	5.04 X 2.13	2.10	1
2	SHUTTER DOOR	2.52 X 2.13	2.10	1
3	SHUTTER DOOR	1.07 X 2.13	2.10	1

SCHEDULE OF JOINERY

NO.	DESCRIPTION	SIZE	HEIGHT	QTY
1	SHUTTER DOOR	0.92 X 2.13	2.10	1
2	SHUTTER DOOR	0.76 X 2.13	2.10	1
3	SHUTTER DOOR	1.52 X 1.22	2.10	1
4	SHUTTER DOOR	1.22 X 1.22	2.10	1
5	SHUTTER DOOR	0.91 X 1.22	2.10	1

MSBIA Table for Building A (AZHARUDDIN DANISH)

NO.	DESCRIPTION	AREA (SQ.M)	PERCENTAGE (%)
1	TOTAL PLOT AREA	136.98	100.00
2	COVERED AREA	93.16	68.01
3	OPEN AREA	43.82	31.99