

Proposal Basic Information	
Proposal File No.	MNAC/BI/0020/W09/2020
Owner Name	SHIKHA GIRI
Khata No	291
Plot No	4471
Village Name	Mango
Use	Residential
SubUse	Bungalow/ Dwelling / Non Apartment

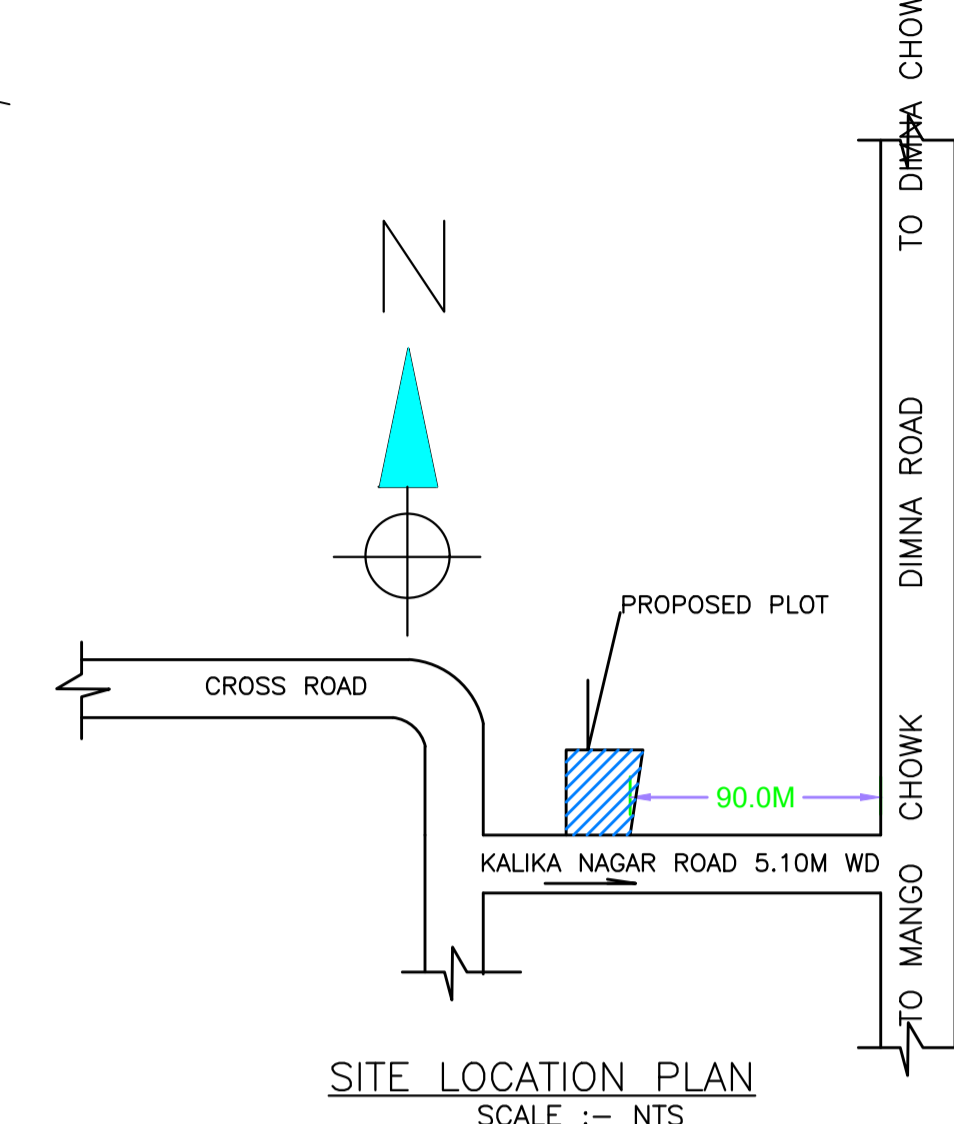

AREA STATEMENT MANGO MUNICIPAL CORPORATION		VERSION NO. : 1.0.46
PROJECT DETAIL:		VERSION DATE: 22/06/2020
Region: JHARKHAND URBAN LOCAL BODIES	Plot Use: Residential	
District: EAST SINGHBHUM	Plot SubUse: Bungalow/ Dwelling / Non Apartment	
Authority: MANGO MUNICIPAL CORPORATION	Plot/Nearby/Religious/Structure: NA	
Inward No: MNAC/BI/0020/W09/2020	Plot/SubPlot No: 4471	
Application Type: General Proposal	North: Plot No. - 4470	
Project Type: Building Permission	South: Road Width - 5.1	
Nature of Development: New	East: Plot No. - 4471	
Location of Development Area: Old Area	West: Plot No. - 4460	
AREA DETAILS:		SQ.MT.
AREA OF PLOT (Minimum)	(A)	99.97
NET AREA OF PLOT(Gross Plot Area - Deduction from Gross Plot area)	(A-Deductions)	99.97
Deduction for Balance Plot Area(from Gross Plot Area)		
Common Plot		13.56
Total		13.56
BALANCE AREA OF PLOT(Net Plot Area - Recreational/Amenity space)	(A-Deductions)	86.41
PLOT AREA FOR COVERAGE(Net Plot Area)	(A-Deductions)	99.97
Plot Area for FAR (Net Plot Area + RoadWidening Area)	(A-Deductions)	99.97
COVERAGE CHECK		
Permissible Coverage area (70.00 %)		69.98
Proposed Coverage Area (60.86 %)		60.84
Total Prop. Coverage Area (60.86 %)		60.84
Balance coverage area (9.14 %)		9.14
FAR CHECK		
Perm. FAR Area (1.80)		179.95
Total Perm. FAR area		179.95
Residential FAR		60.84
Proposed FAR Area		71.00
Total Proposed FAR Area		71.00
Consumed FAR (Factor)		0.71
Balance FAR Area		108.95
BUILT UP AREA CHECK		
Total Proposed BuiltUp Area		121.68
ARCHITECT (Regd)		Chandrika Sharma
ENGINEER (Regd)		
SUPERVISOR (Regd)		
OWNER (Regd)		SHIKHA GIRI
DEVELOPMENT AUTHORITY		LOCAL BODY

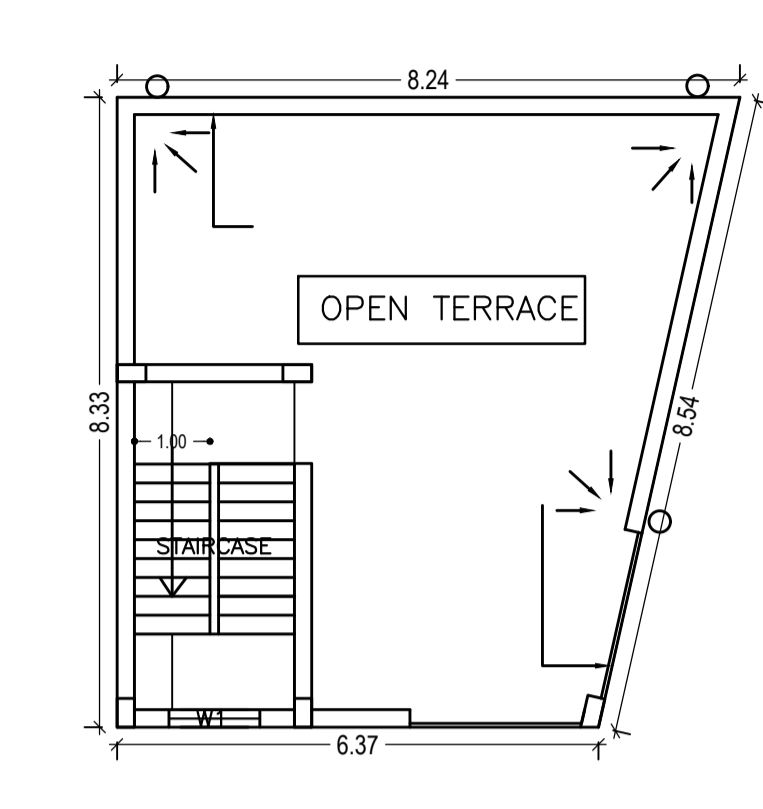
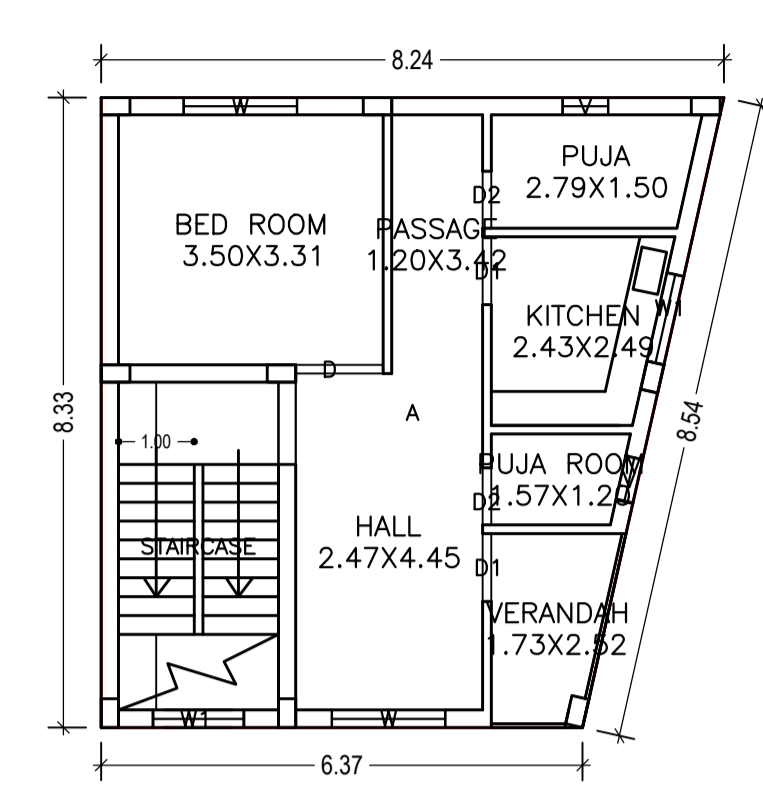
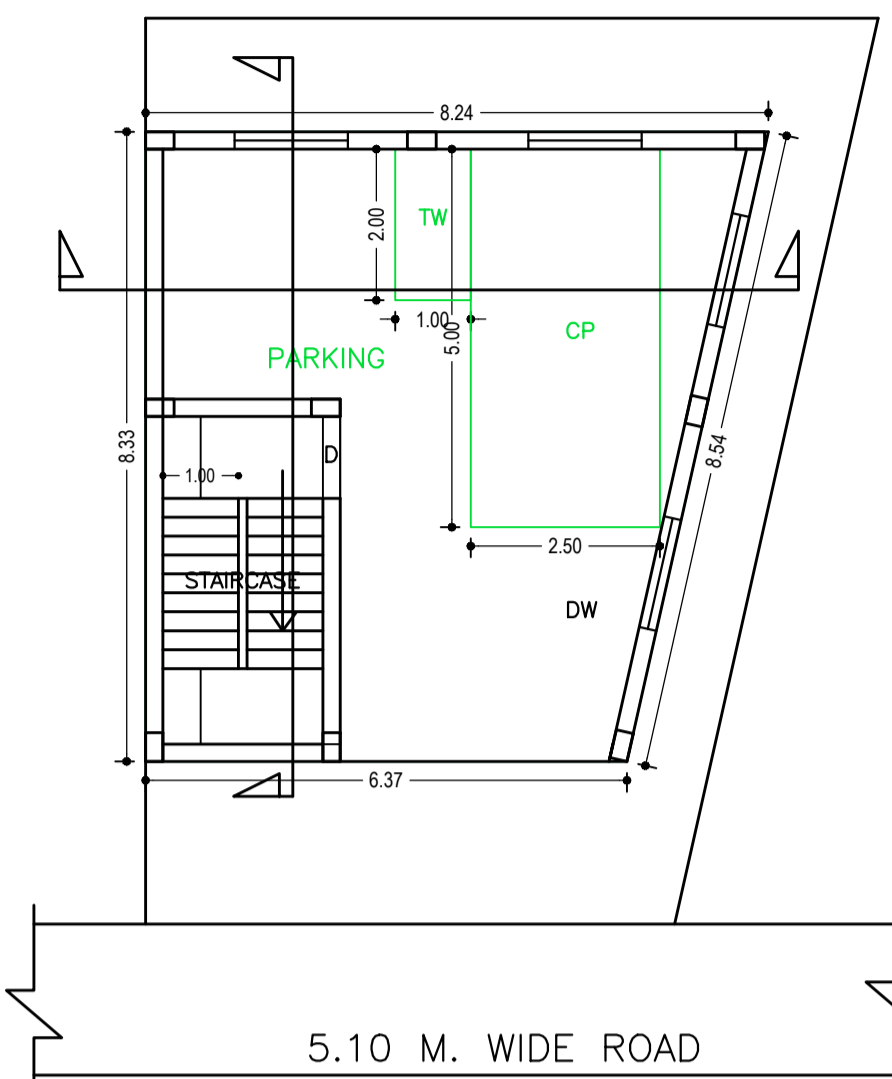
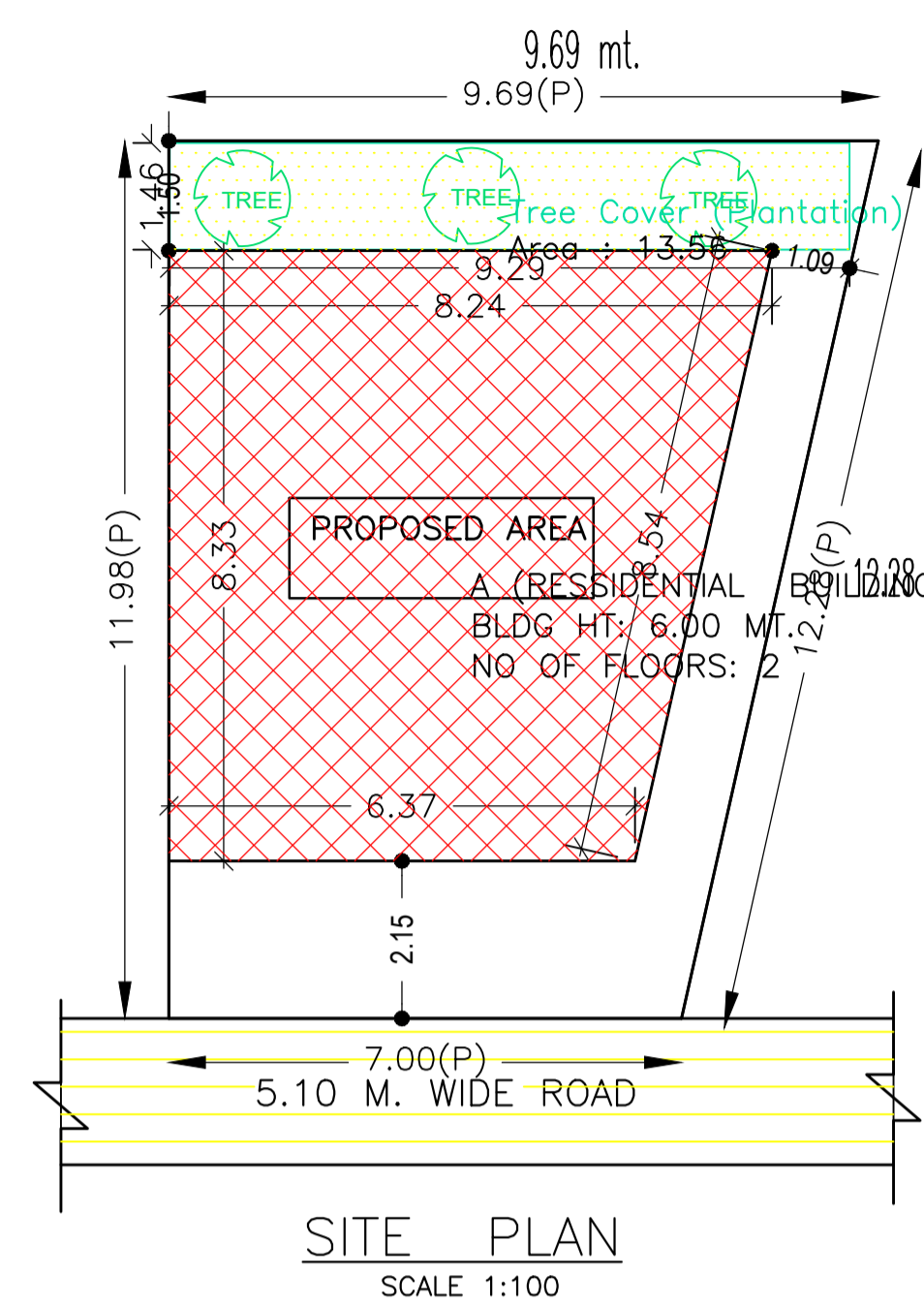
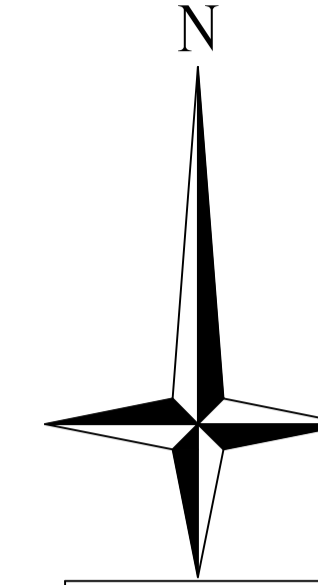
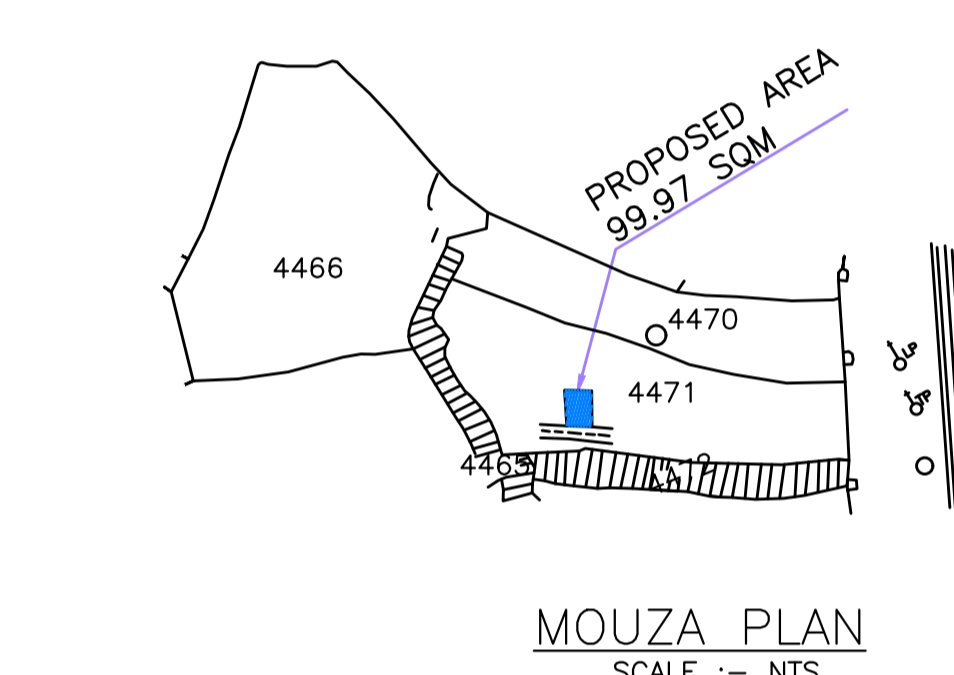
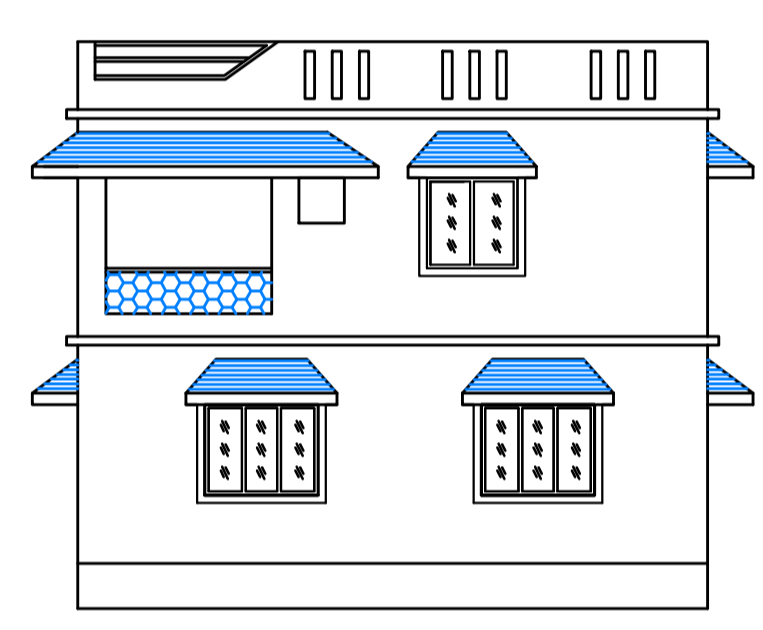
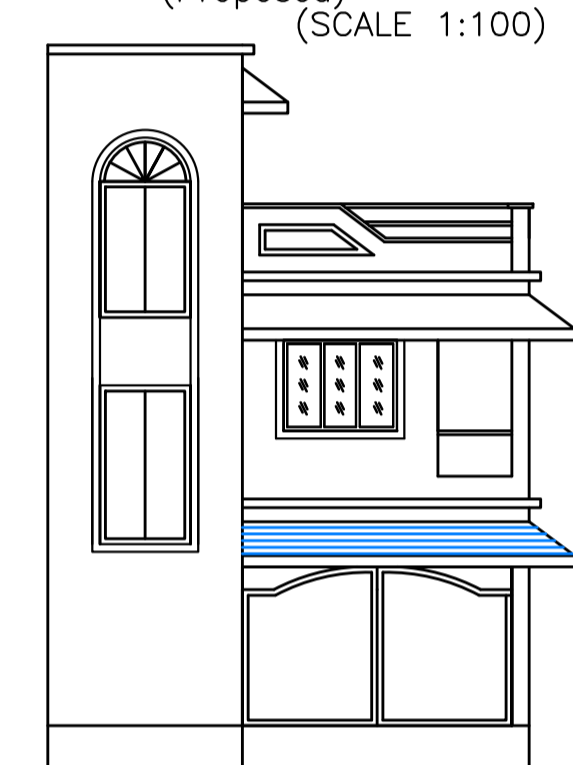
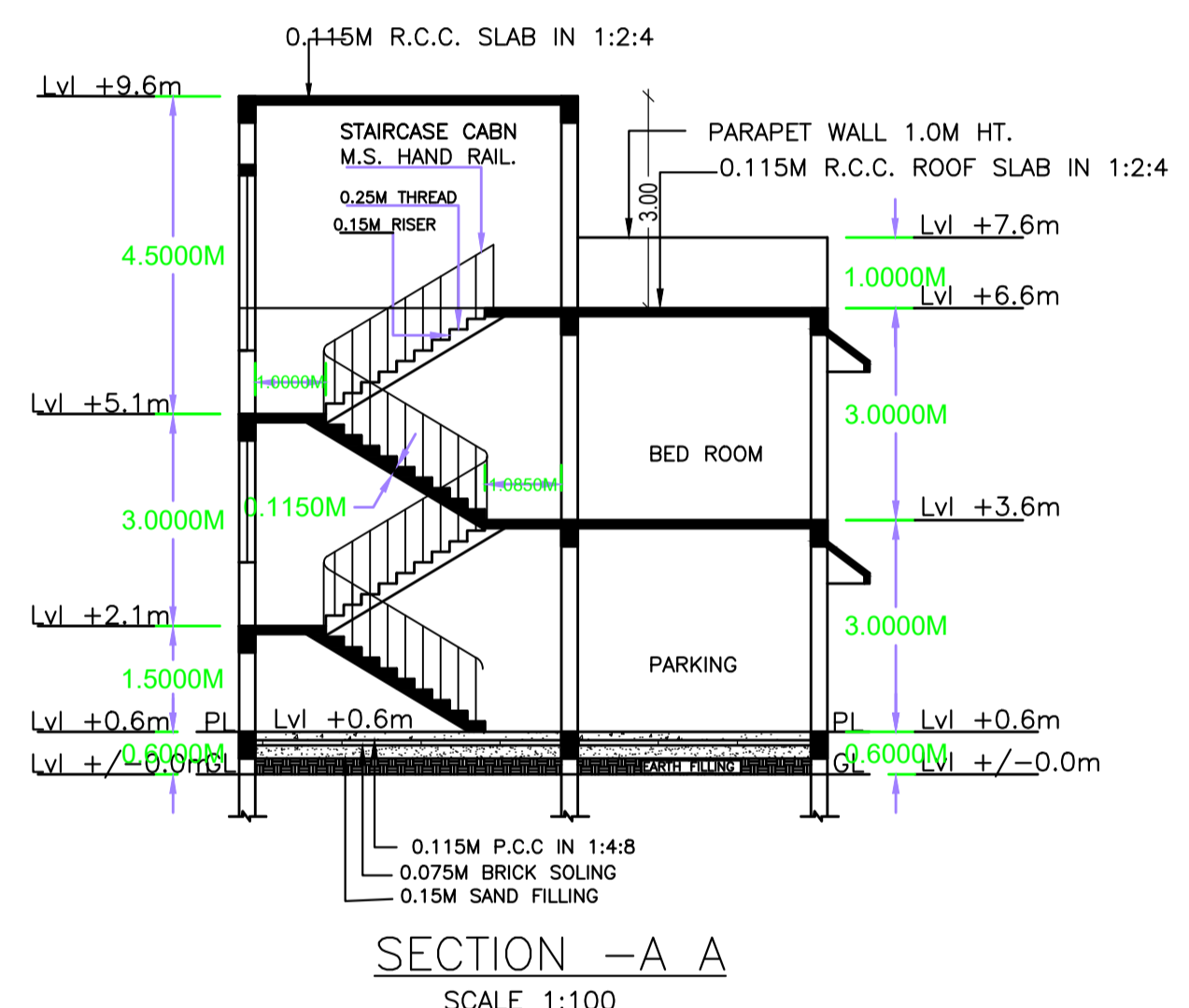
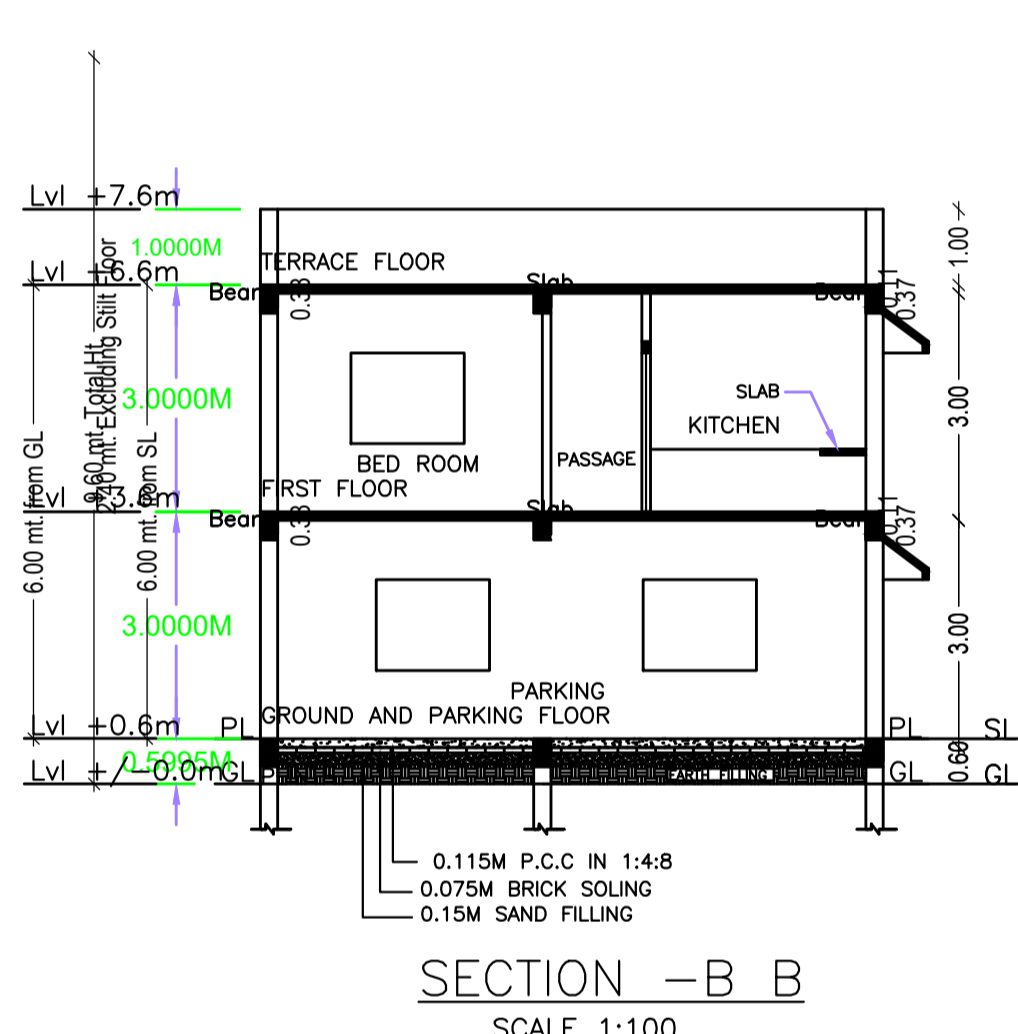

Building :A (RESIDENTIAL BUILDING)						
Floor Name	Total Built Up Area (Sq.mt.)	Deductions (Area in Sq.mt.)	Proposed FAR Area (Sq.mt.)	Add Area In FAR (Sq.mt.)	Total FAR Area (Sq.mt.)	Total Consumed Additional FAR Area (Sq.mt.)
Ground And Parking Floor	60.84	50.67	0.00	10.17	10.17	10.17
First Floor	60.84	0.00	60.84	0.00	60.84	60.84
Terrace Floor	0.00	0.00	0.00	0.00	0.00	0.00
Total :	121.68	50.67	60.84	10.17	71.01	71.01
Total Number of Same Buildings :	1					
Total :	121.68	50.67	60.84	10.17	71.01	71.01

COLOR INDEX	
PLOT BOUNDARY	Black
ABUTTING ROAD	Red
PROPOSED CONSTRUCTION	Green
COMMON PLOT	Yellow
ROAD WIDENING AREA	Blue
EXISTING (To be retained)	Light Blue
EXISTING (To be demolished)	Dark Blue

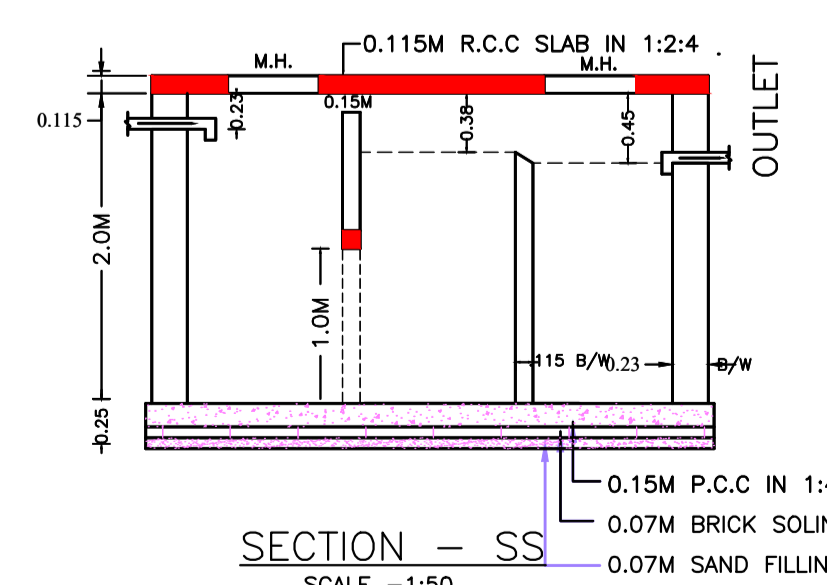
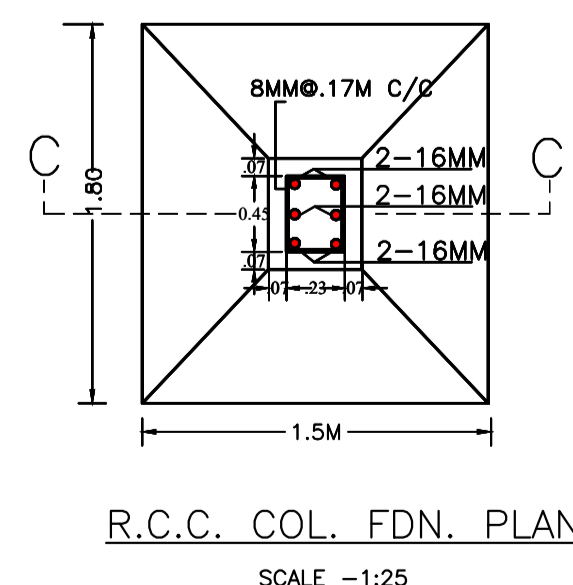
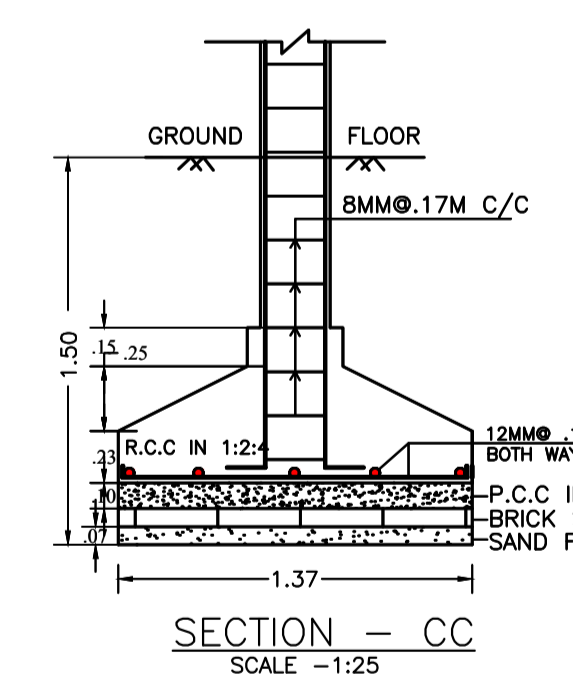
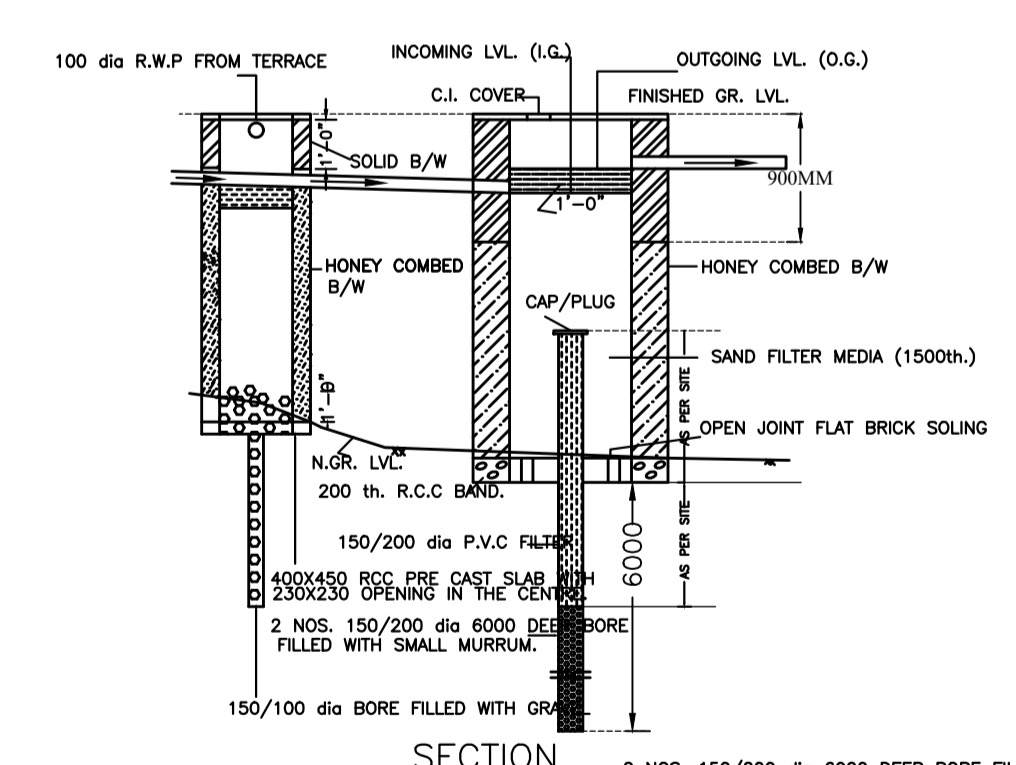
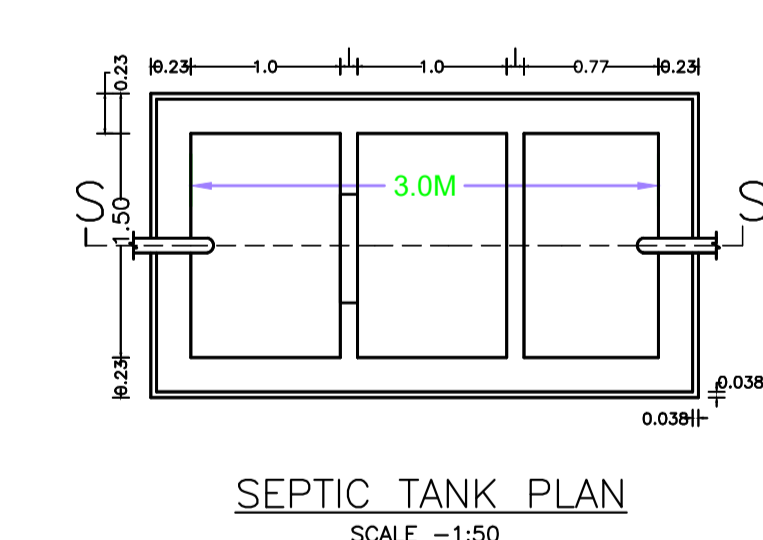

SCHEDULE OF DOOR:				
BUILDING NAME	NAME	LENGTH	HEIGHT	NOS
A (RESIDENTIAL BUILDING)	D2	0.75	2.10	02
A (RESIDENTIAL BUILDING)	D1	0.90	2.10	02
A (RESIDENTIAL BUILDING)	D	1.16	2.10	01

SCHEDULE OF WINDOW/VENTILATION:				
BUILDING NAME	NAME	LENGTH	HEIGHT	NOS
A (RESIDENTIAL BUILDING)	V	0.60	0.60	01
A (RESIDENTIAL BUILDING)	V	0.60	0.75	01
A (RESIDENTIAL BUILDING)	W1	1.20	1.20	03
A (RESIDENTIAL BUILDING)	W	1.50	1.20	02

UnitBUA Table for Building :A (RESIDENTIAL BUILDING)						
FLOOR	Name	UnitBUA Type	UnitBUA Area	Carpet Area	No. of Rooms	No. of Tenement
FIRST FLOOR	A	FLAT	60.84	52.78	7	1
Total:	-	-	60.84	52.78	7	1

Buildingwise Floor FAR Details				
Floor Name	Building Name		Total	
	Proposed Built Up Area (Sq.mt.)	Proposed FAR Area (Sq.mt.)	Total Proposed Built Up Area (Sq.mt.)	Total FAR Area (Sq.mt.)
Ground And Parking Floor	60.84	10.17	60.84	10.17
First Floor	60.84	60.84	60.84	60.84
Terrace Floor	0.00	0.00	0.00	0.00
Total :	121.68	71.01	121.68	71.01

Building USE/SUBUSE Details			
Building Name	Building Use	Building SubUse	Building Structure
A (RESIDENTIAL BUILDING)	Residential	Residential Bldg/Apartment	Non-Highrise

FAR & Tenement Details (Table 4c-1)								
Building	No. of Same Bldg	Total Built Up Area (Sq.mt.)	Deductions (Area in Sq.mt.)	Proposed FAR Area (Sq.mt.)	Add Area In FAR (Sq.mt.)	Total FAR Area (Sq.mt.)	Total Consumed Additional FAR Area (Sq.mt.)	Tnmt (No.)
A (RESIDENTIAL BUILDING)	1	121.68	50.67	60.84	10.17	71.01	71.01	01
Grand Total:	1	121.68	50.67	60.84	10.17	71.01	71.01	01

LTP NAME AND SIGNATURE	STRUCTURAL ENG'S NAME AND SIGNATURE	BUILDER NAME AND SIGNATURE	DIGITAL SIGNATURE
Chandrika Sharma MNAC/DFTMN/0017/2017			