

Proposal Basic Information

Proposal File No.	MNAC/BP/0029/W10/2020
Owner Name	RAJ KUMAR GUPTA
Khata No	233
Plot No	3284
Village Name	Mango
Use	Residential
SubUse	Bungalow/ Dwelling / Non Apartment

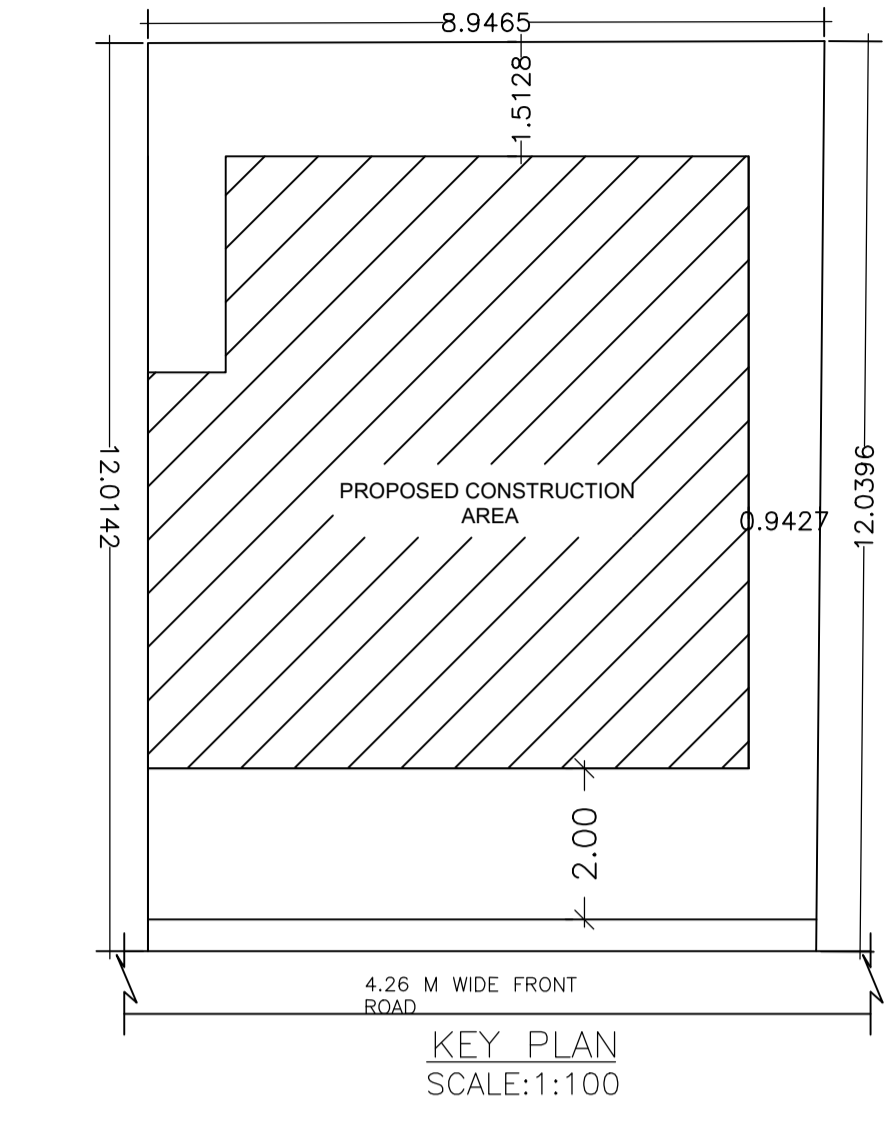

AREA STATEMENT MANGO MUNICIPAL CORPORATION	VERSION NO.: 1.0.48	VERSION DATE: 22/06/2020
PROJECT DETAIL:		
Region: JHARKHAND URBAN LOCAL BODIES	Plot Use: Residential	
District: EAST SINGHBHUM	Plot SubUse: Bungalow/ Dwelling / Non Apartment	
Authority: MANGO MUNICIPAL CORPORATION	PlotNearby/ReligiousStructure: NA	
Inward No: MNAC/BP/0029/W10/2020	Plot/SubPlot No: 3284	
Application Type: General Proposal	North: -	
Project Type: Building Permission	East: -	
Nature of Development: New	West: -	
Location of Development Area: Old Area		
AREA DETAILS:		
AREA OF PLOT (Minimum)	(A)	SQ.MT. 104.95
Deduction for NetPlot Area		
Surrender Free of Cost		3.71
Total		3.71
NET AREA OF PLOT(Gross Plot Area - Deduction from Gross Plot area)	(A-Deductions)	101.24
Deduction for Balance Plot Area(from Gross Plot Area)		
Surrender Free of Cost		3.71
Common Plot		7.76
Total		11.47
BALANCE AREA OF PLOT(Net Plot Area - Recreational/Amenity space)	(A-Deductions)	93.48
PLOT AREA FOR COVERAGE(Net Plot Area)	(A-Deductions)	101.24
Plot Area for FAR (Net Plot Area + RoadWidening Area)	(A-Deductions)	104.95
COVERAGE CHECK		
Permissible Coverage area (70.00 %)		70.87
Proposed Coverage Area (60.64 %)		61.39
Total Prop. Coverage Area (60.64 %)		61.39
Balance coverage area (9.36 %)		9.48
FAR CHECK		
Perm. FAR Area (1.50)		157.42
Total Perm. FAR area		157.42
Residential FAR		61.39
Proposed FAR Area		61.39
Total Proposed FAR Area		61.39
Consumed FAR (Factor)		0.58
Balance FAR Area		96.03
BUILT UP AREA CHECK		
Total Proposed BuiltUp Area		61.39
ARCHITECT (Regd)	MOHAMMAD BELAL NASIR	
ENGINEER (Regd)		
SUPERVISOR (Regd)		
OWNER (Regd)	RAJ KUMAR GUPTA	
DEVELOPMENT AUTHORITY		LOCAL BODY

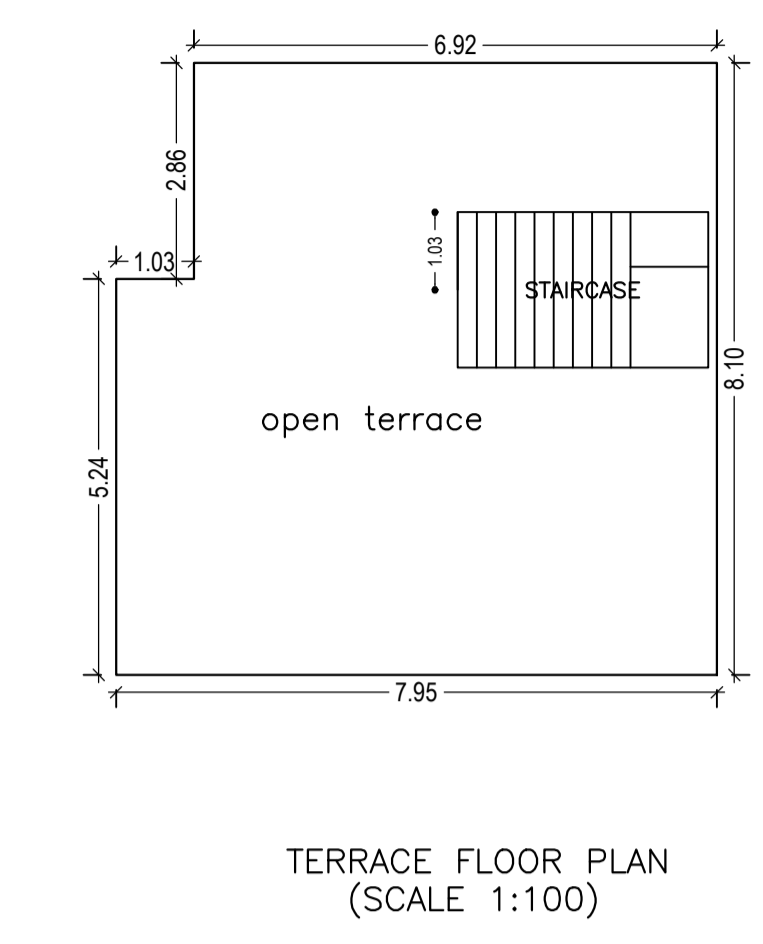
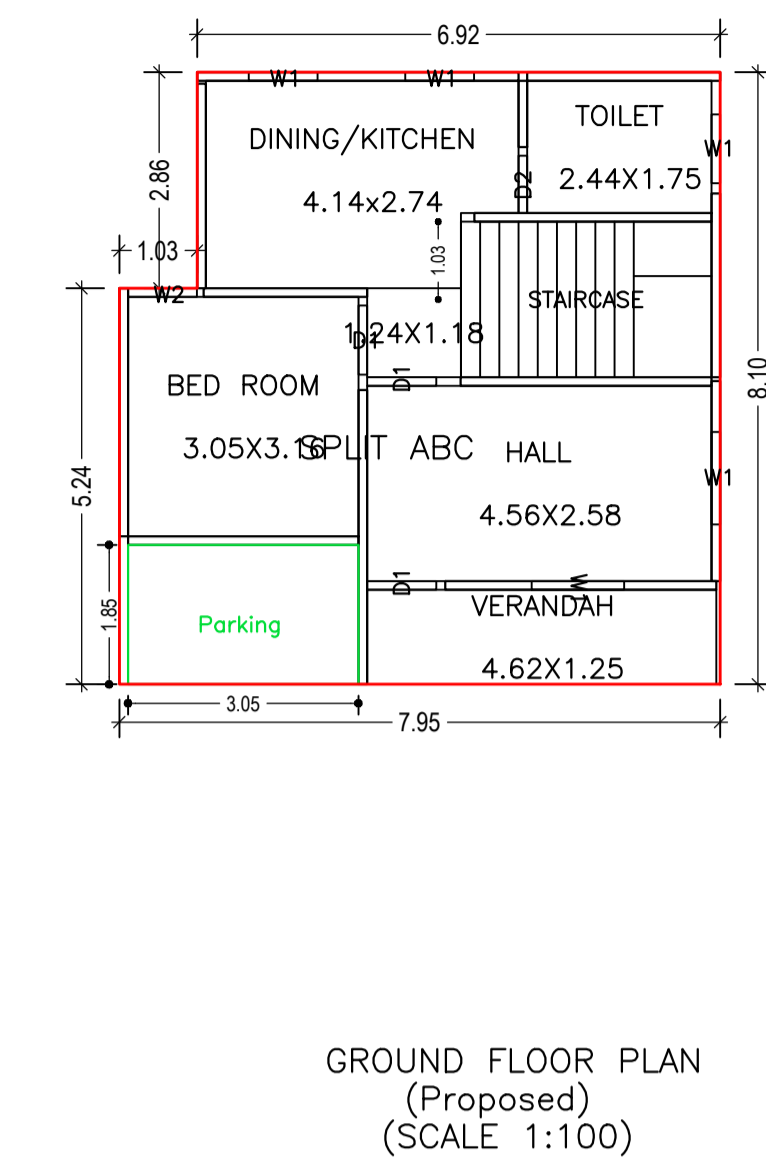
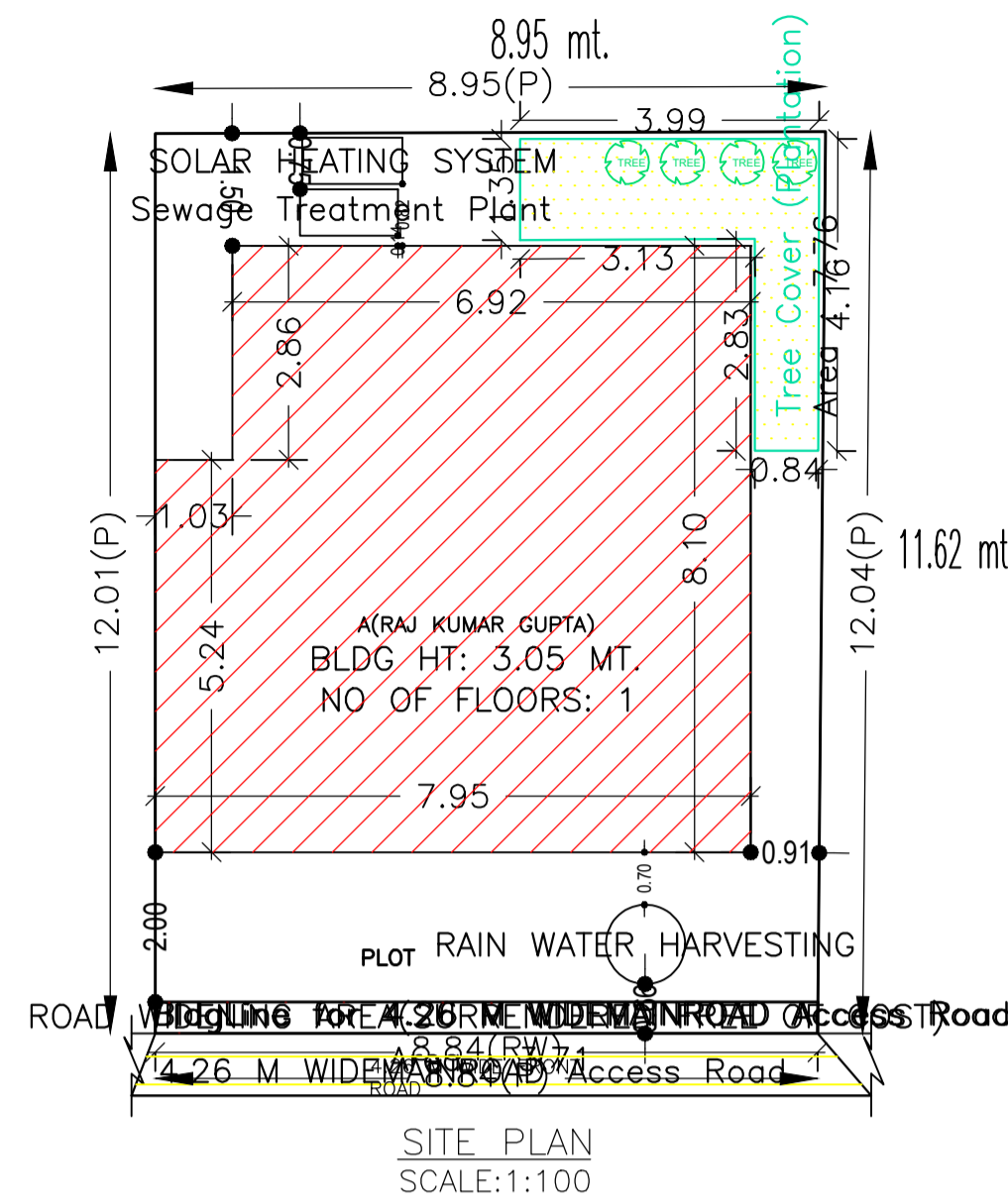
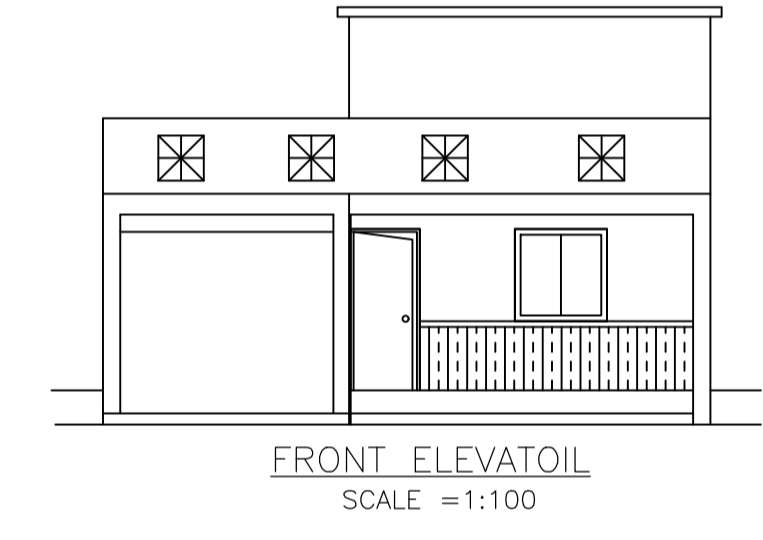
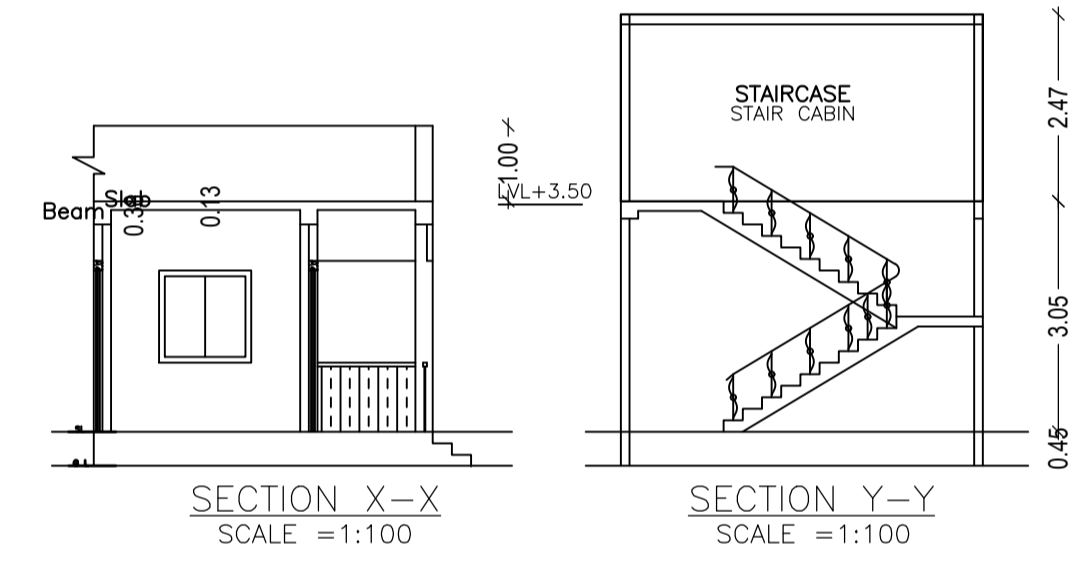
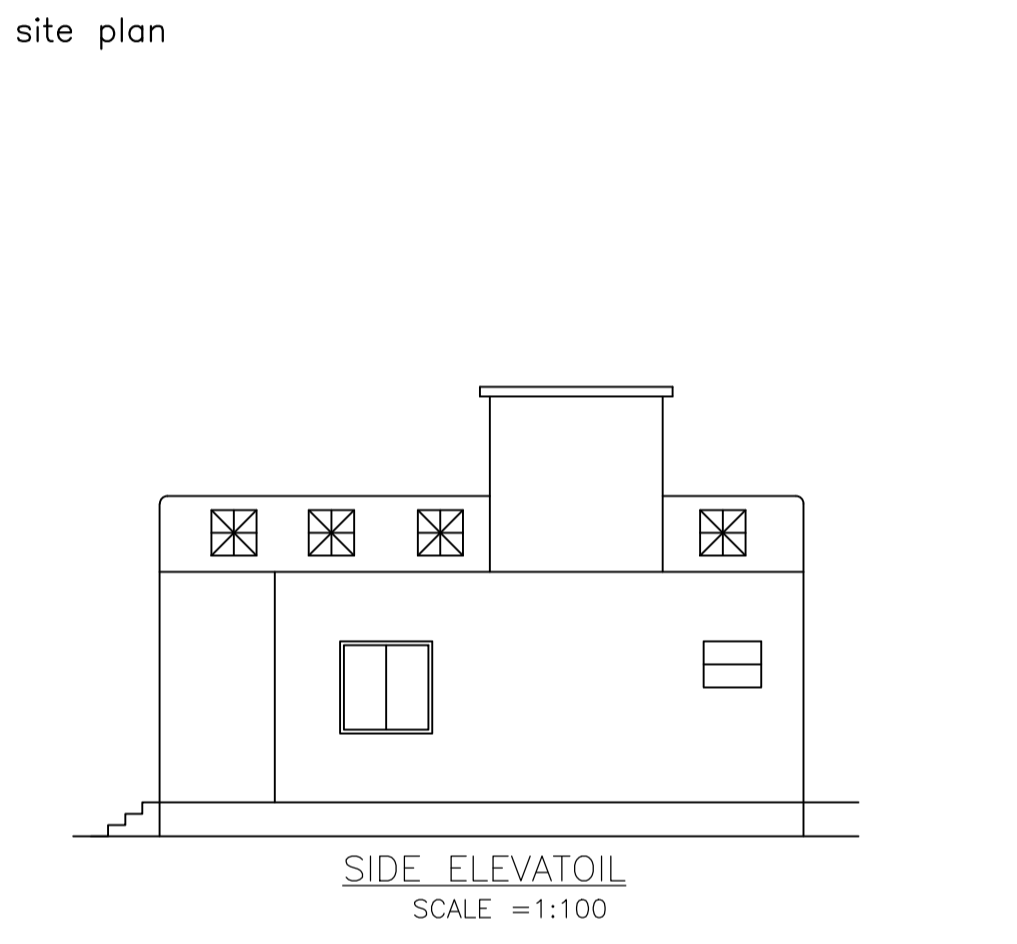

SCHEDULE OF DOOR:

BUILDING NAME	NAME	LENGTH	HEIGHT	NOS
A(RAJ KUMAR GUPTA)	D2	0.76	2.13	01
A(RAJ KUMAR GUPTA)	D1	0.91	2.13	03

SCHEDULE OF WINDOW/VENTILATION:

BUILDING NAME	NAME	LENGTH	HEIGHT	NOS
A(RAJ KUMAR GUPTA)	W1	0.91	1.22	03
A(RAJ KUMAR GUPTA)	W2	0.91	1.22	01
A(RAJ KUMAR GUPTA)	W1	1.22	1.22	02

UnitBUA Table for Building :A(RAJ KUMAR GUPTA)

FLOOR	Name	UnitBUA Type	UnitBUA Area	Carpet Area	No. of Rooms	No. of Tenement
GROUND FLOOR PLAN	SPLIT ABC	FLAT	61.39	57.06	5	1
Total:	-	-	61.39	57.06	5	1

Building :A(RAJ KUMAR GUPTA)

Floor Name	Total Built Up Area (Sq.mt.)	Proposed FAR Area (Sq.mt.) Resi.	Total FAR Area (Sq.mt.)	Total Consumed Additional FAR Area (Sq.mt.)	Tnmt (No.)
Ground Floor	61.39	61.39	61.39	61.39	01
Terrace Floor	0.00	0.00	0.00	0.00	00
Total	61.39	61.39	61.39	61.39	01
Total Number of Same Buildings	1				
Total :	61.39	61.39	61.39	61.39	01

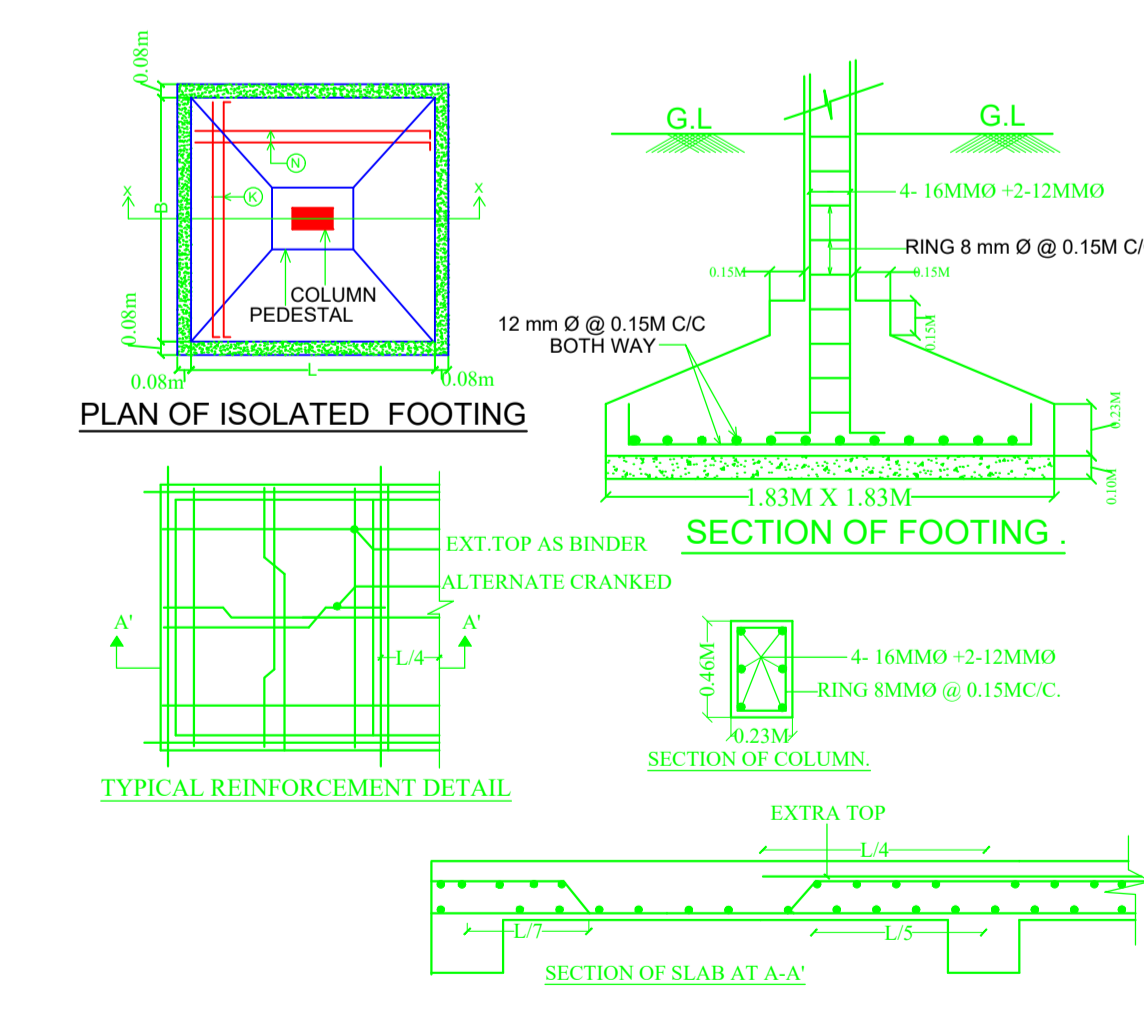
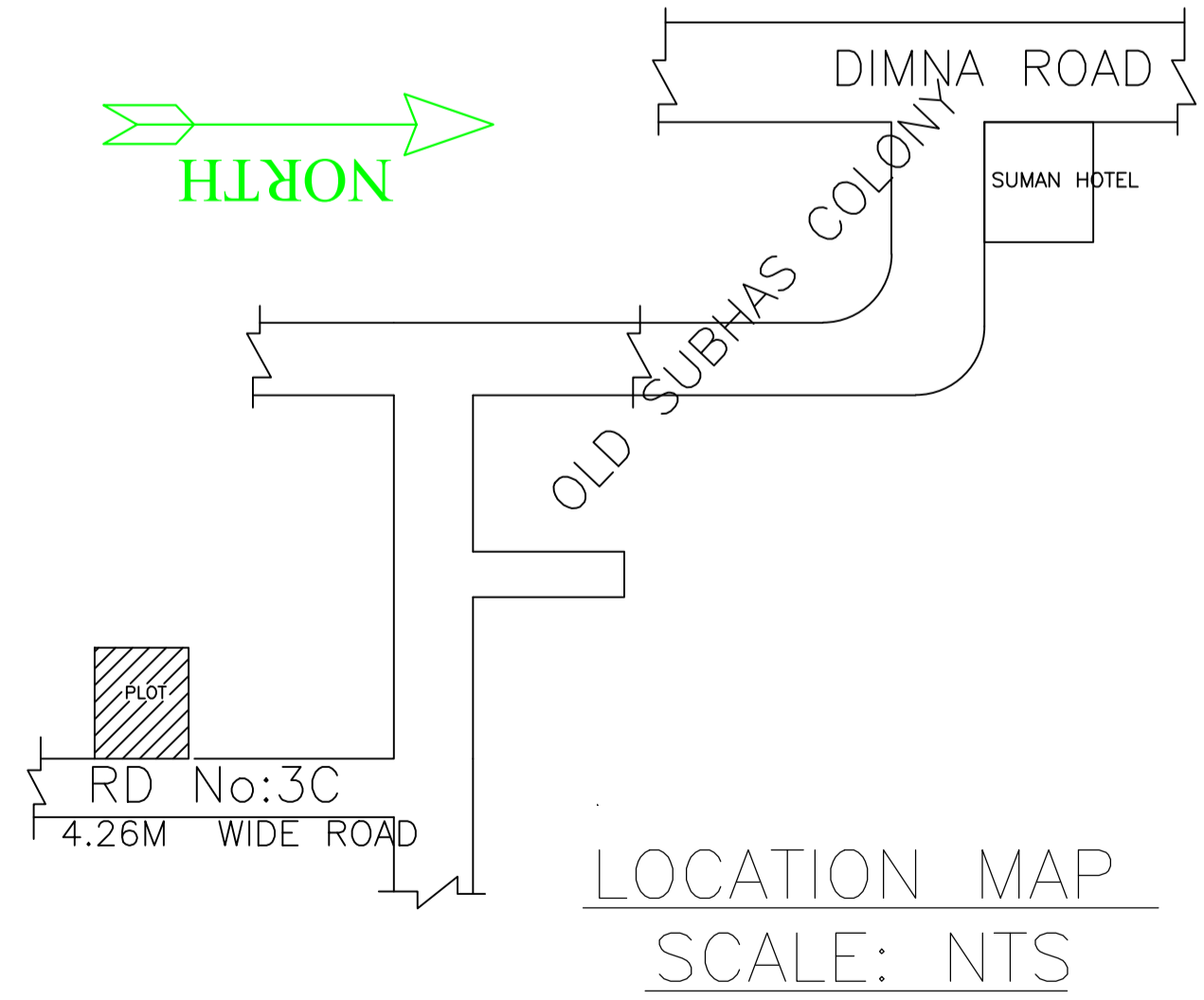

COLOR INDEX

PLOT BOUNDARY	Black
ABUTTING ROAD	Green
PROPOSED CONSTRUCTION	Red
COMMON PLOT	Yellow
ROAD WIDENING AREA	Blue
EXISTING (To be retained)	Orange
EXISTING (To be demolished)	Light Blue

Buildingwise Floor FAR Details

Floor Name	Building Name A(RAJ KUMAR GUPTA)		Total	
	Proposed Built Up Area (Sq.mt.)	Proposed FAR Area (Sq.mt.)	Total Proposed Built Up Area (Sq.mt.)	Total FAR Area (Sq.mt.)
Ground Floor	61.39	61.39	61.39	61.39
Terrace Floor	0.00	0.00	0.00	0.00
Total :	61.39	61.39	61.39	61.39

FAR & Tenement Details (Table 4c-1)

Building	No. of Same Bldg	Total Built Up Area (Sq.mt.)	Proposed FAR Area (Sq.mt.) Resi.	Total FAR Area (Sq.mt.)	Total Consumed Additional FAR Area (Sq.mt.)	Tnmt (No.)
A(RAJ KUMAR GUPTA)	1	61.39	61.39	61.39	61.39	01
Grand Total :	1	61.39	61.39	61.39	61.39	01

Building USE/SUBUSE Details

Building Name	Building Use	Building SubUse	Building Structure
A(RAJ KUMAR GUPTA)	Residential	Residential Bldg/Apartment	Non-Highrise

LTP NAME AND SIGNATURE	STRUCTURAL ENG'S NAME AND SIGNATURE	BUILDER NAME AND SIGNATURE	DIGITAL SIGNATURE
MOHAMMAD BELAL NASIR MNAC/ENG/0007/2016			