

**CALCULATION FOR WATER TANK**  
 CONSIDERING FOR 15 PERSONS = 15 X 135 = 2025 LTS.  
 APPROVIDED = 5,000 LTS.

**CALCULATION FOR SEPTIC TANK**  
 CONSIDERING FOR 15 PERSONS = 15 X 0.083 = 1.245 CUM  
 APROVIDED = 2.78X1.06X1.5 = 4.4202 CUM

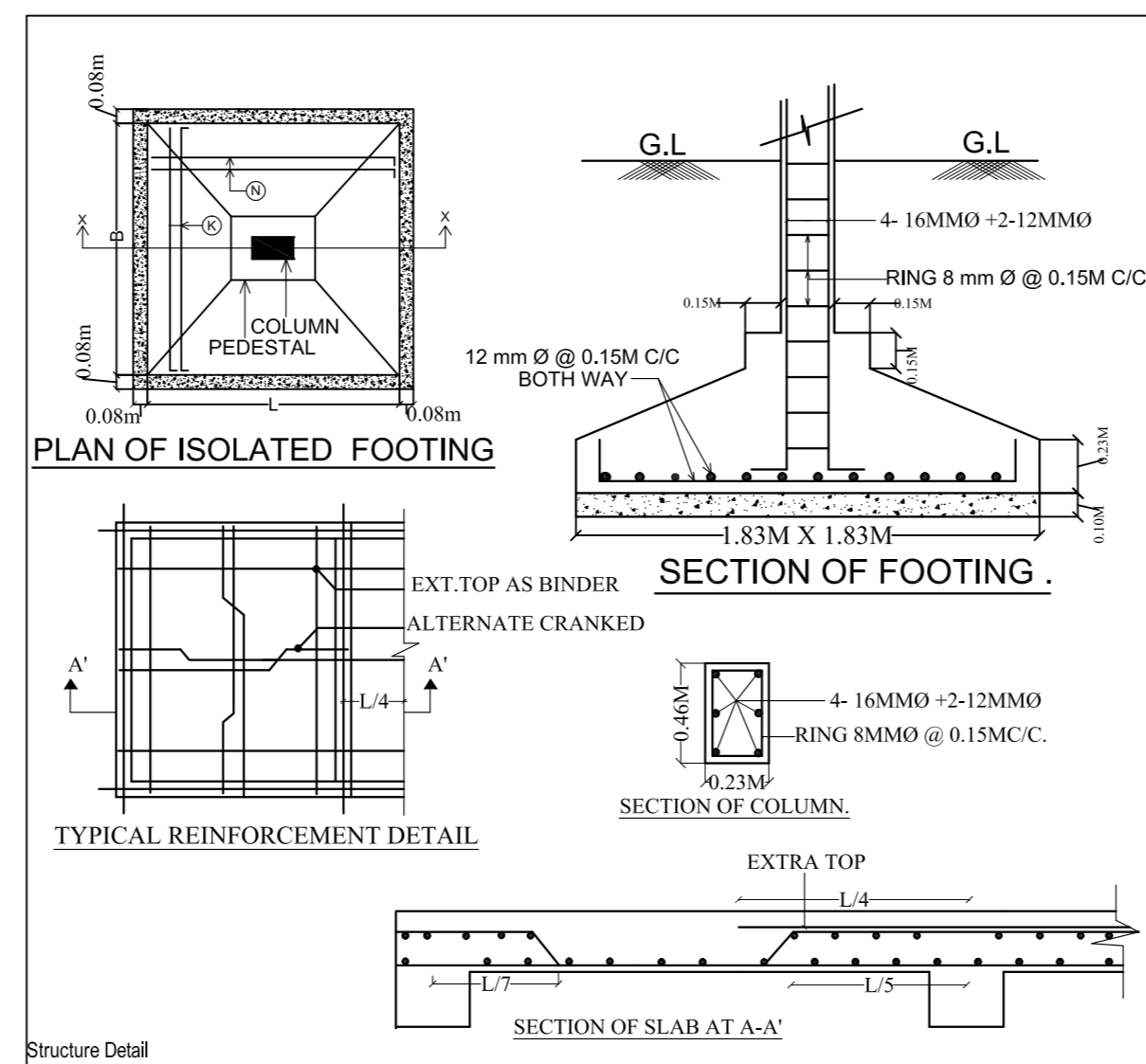

SCHEDULE OF DOOR & WINDOW				
TYPE	WIDTH	HT.	SILL	DESCRIPTION
D	1.07	2.13	0	WOODEN FLUSH DOOR
D1	0.99	2.13	0	WOODEN FLUSH DOOR
D2	0.76	2.13	0	WOODEN FLUSH DOOR
W	1.52	1.52	0.61	GLAZED WINDOW
W1	1.22	1.52	0.61	GLAZED WINDOW
W2	0.91	1.52	0.61	GLAZED WINDOW
V	0.76	0.61	1.52	GLAZED VENTILATOR

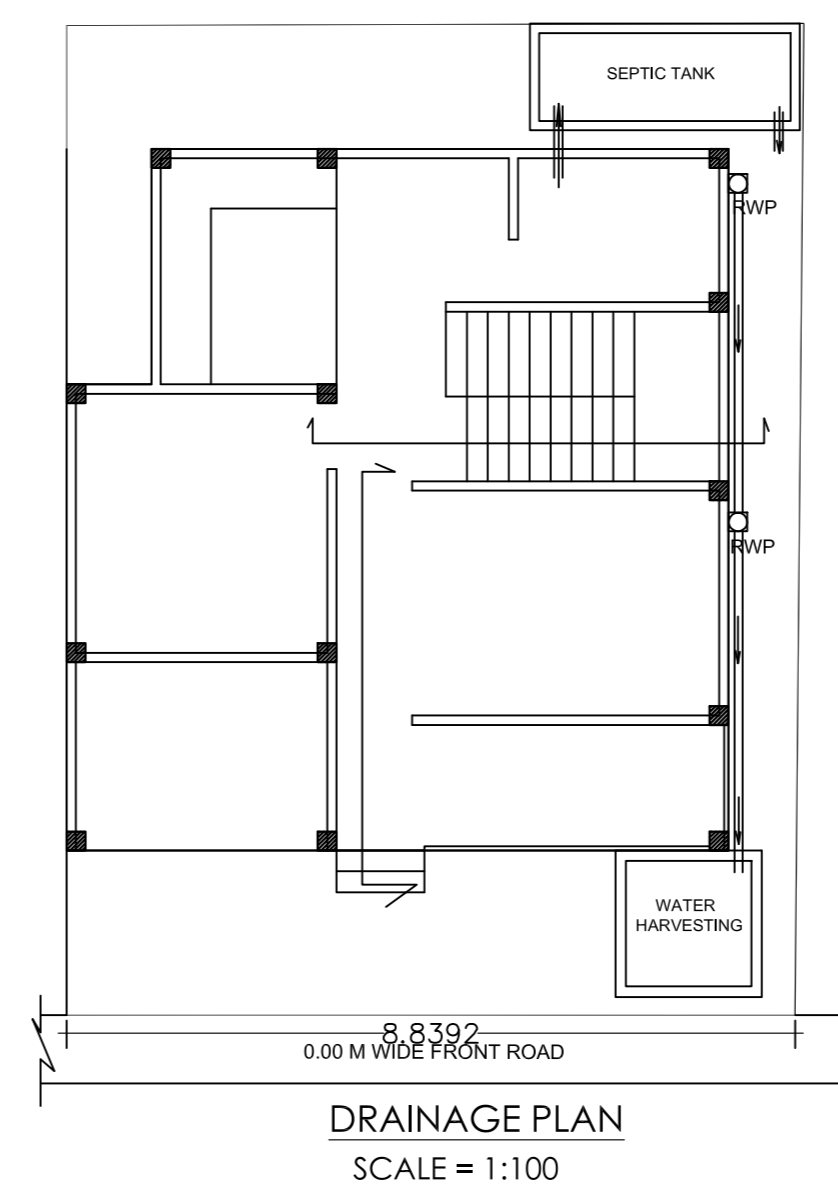
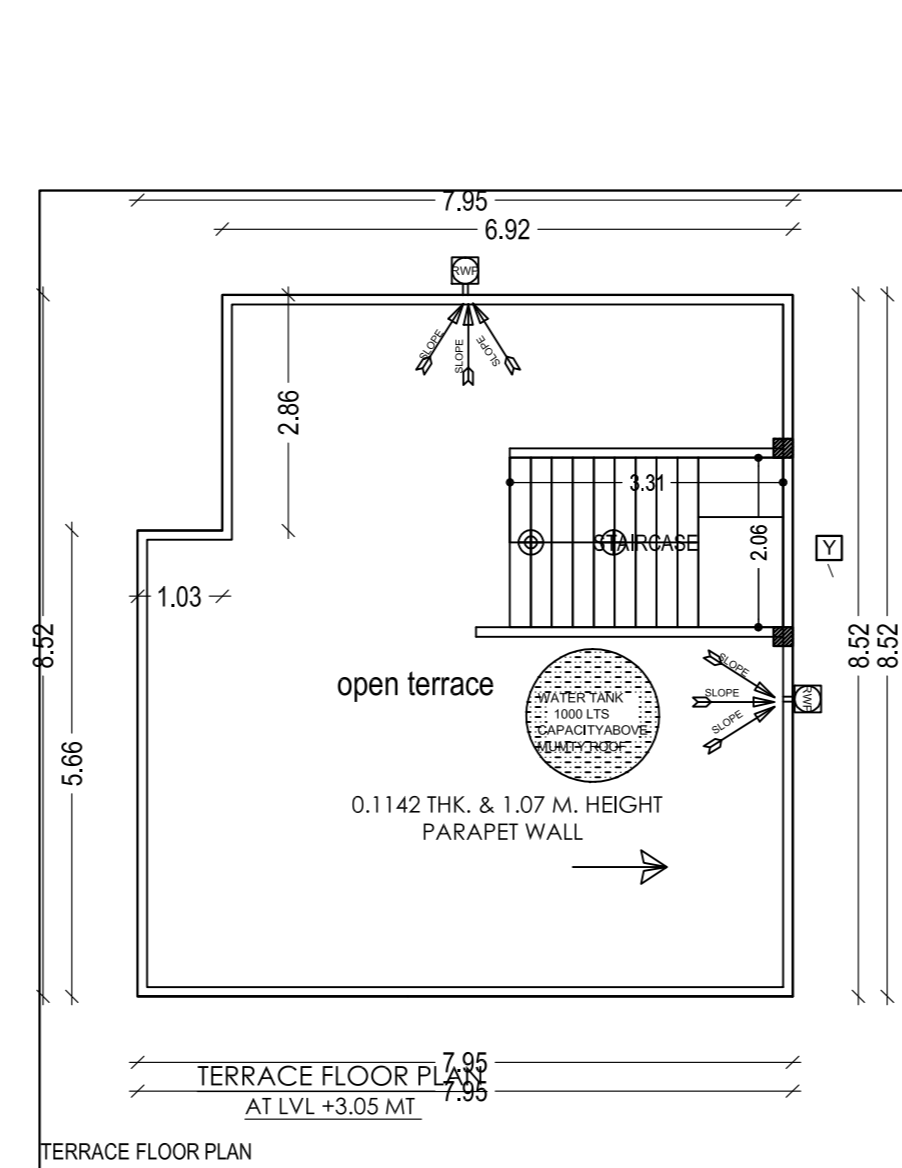
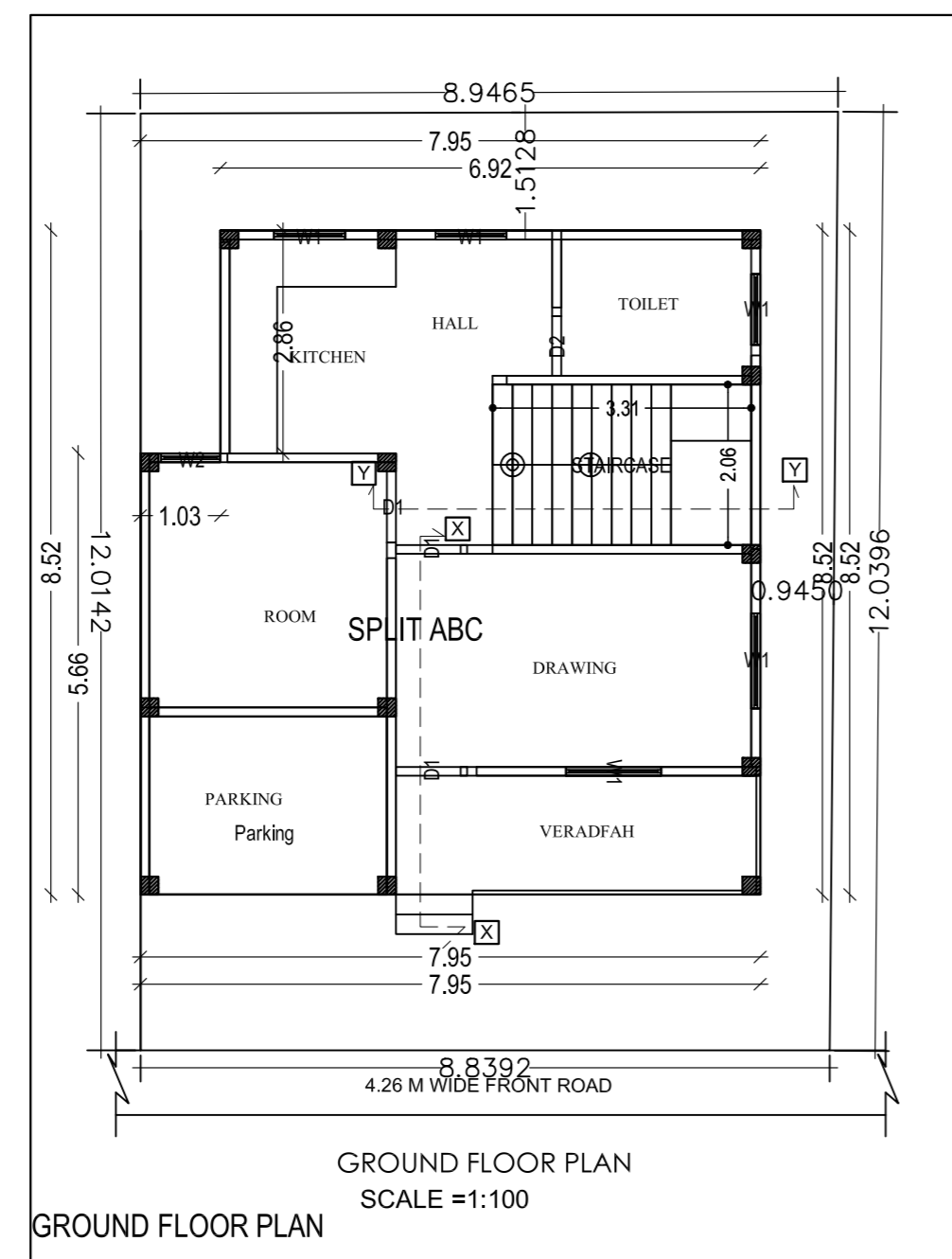
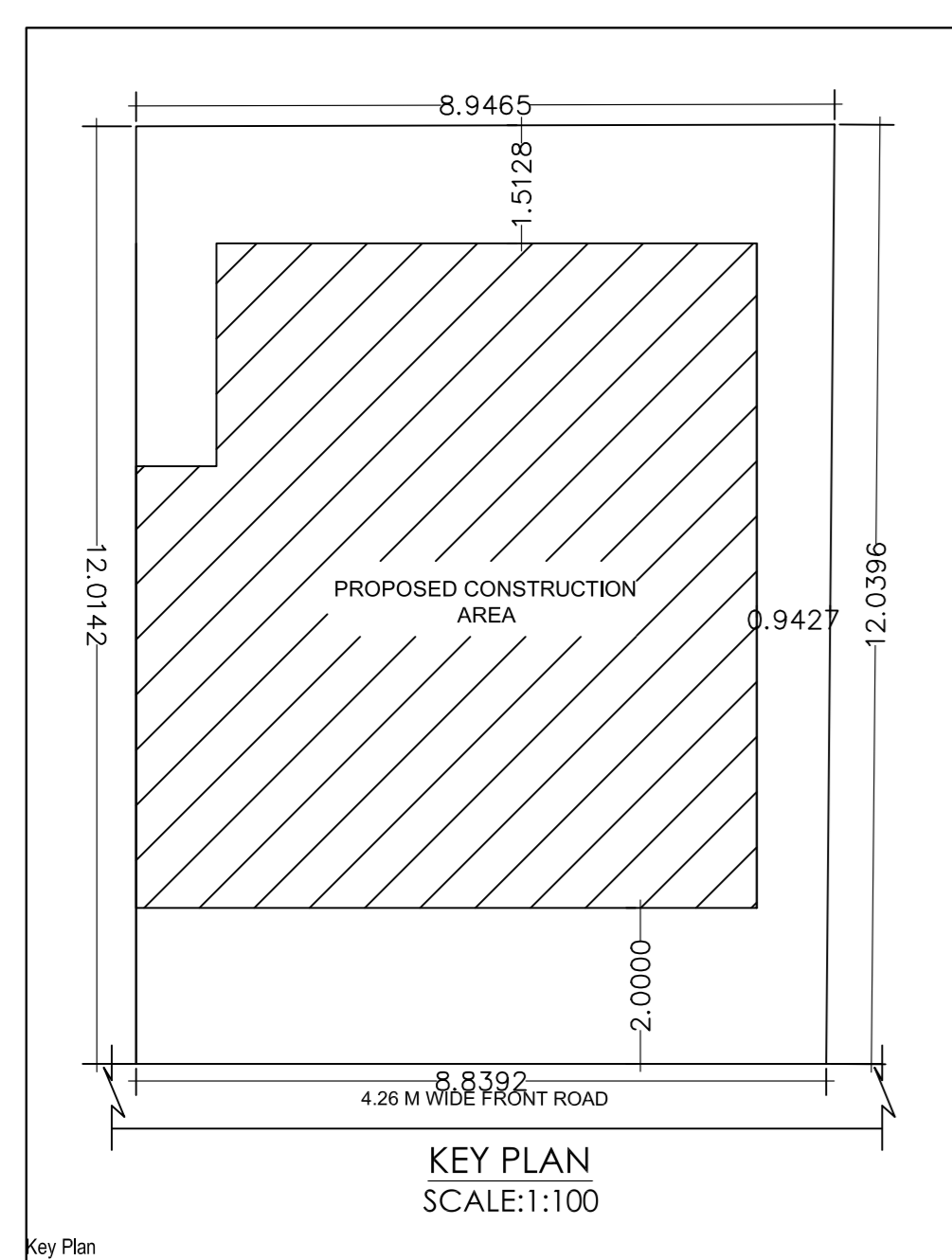
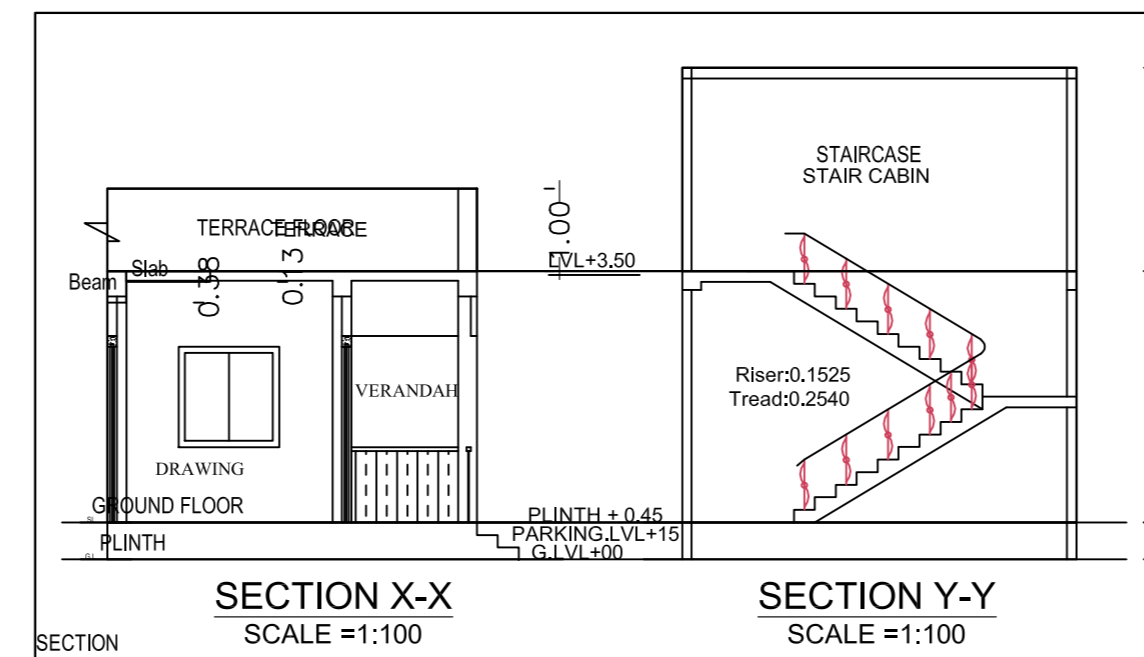
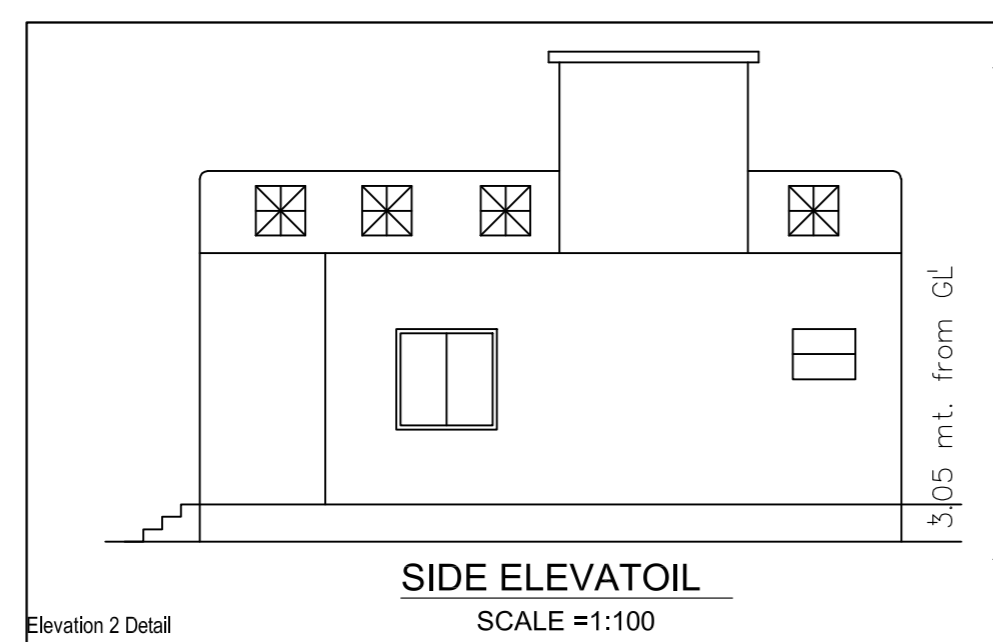
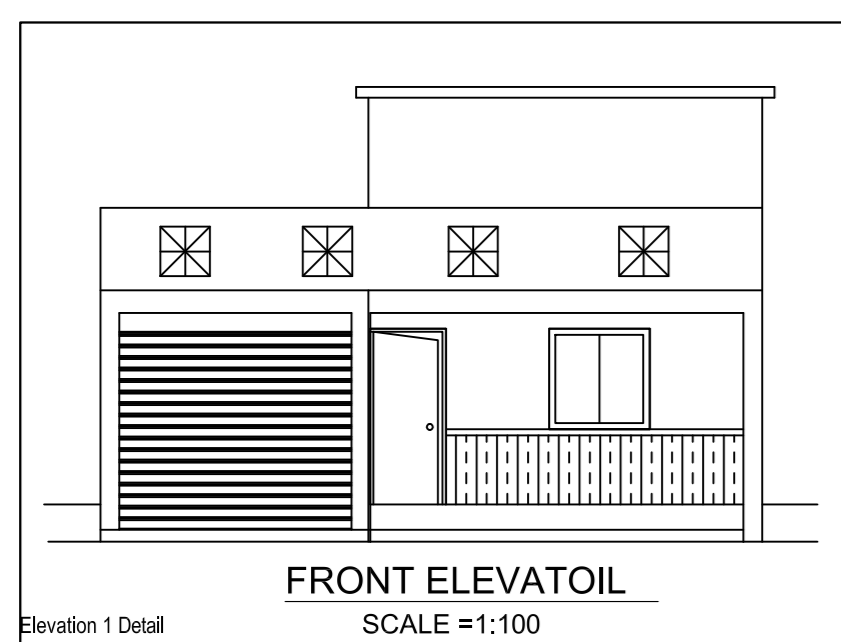
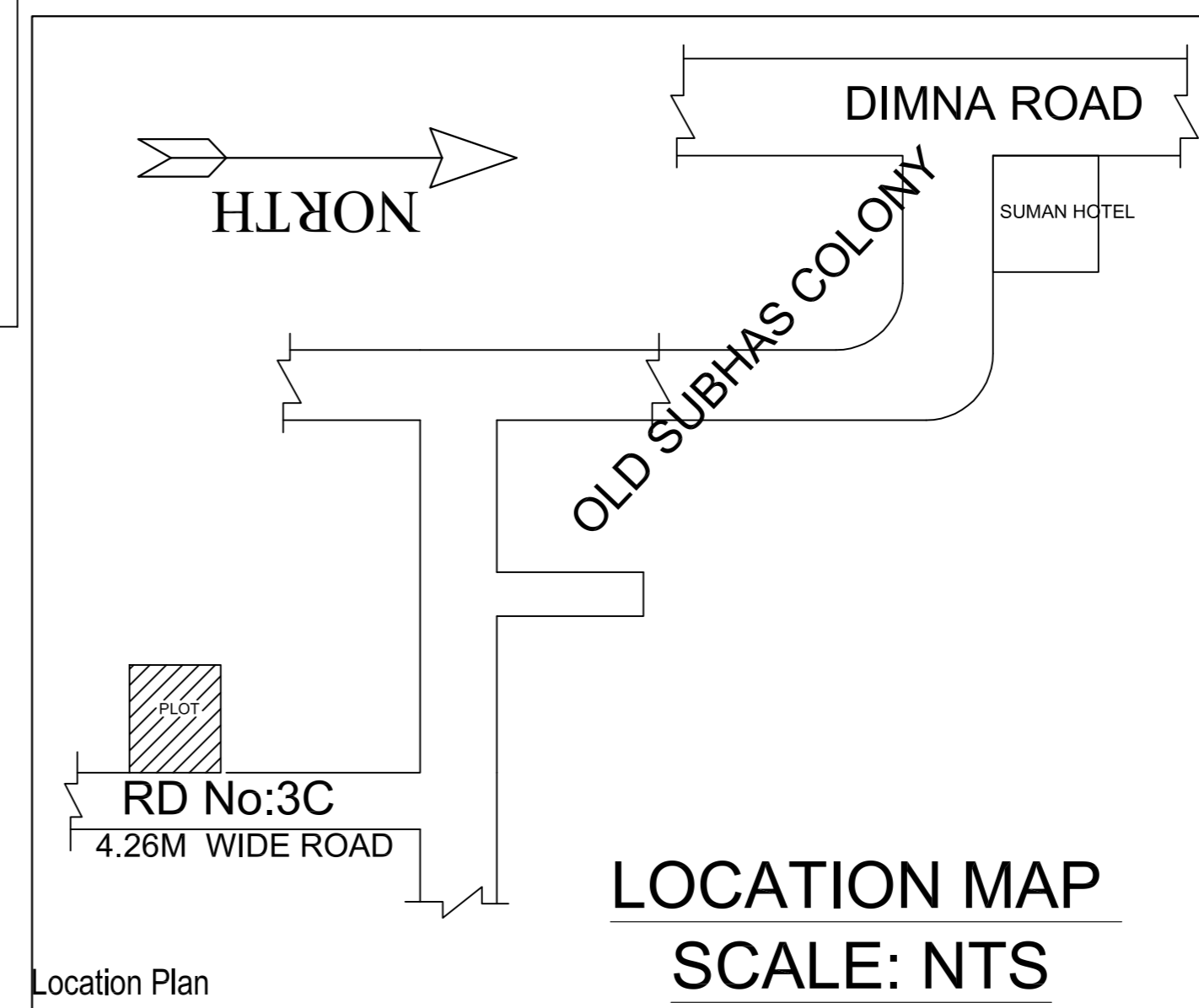

PROPOSED RESIDENTIAL BUILDING PLAN FOR	
LAND OWNER	SIGNATURE
MR. RAJ KUMAR GUPTA S/O:- JAI HIND GUPTA	

**DETAILS OF PLOT :-**  
 PLOT NO:-3284  
 KHATA NO :- 233  
 MOUZA :- MANGO  
 WARD NO :- 10  
 THANA NO:- 1642, P.S:- MANGO  
 DISTRICT :- EAST SINGHBHUM, JHARKHAND

CONTENTS :-	
* SITE PLAN	* TERRACE PLAN
* GROUND FLOOR PLAN	* FRONT ELEVATION
* FIRST FLOOR PLAN	* SIDE ELEVATION
* SECOND FLOOR PLAN	* SECTION "X-X"
* DRAINAGE PLAN	* SECTION "Y-Y"
* GROUND COVERAGE	* LOCATION MAP
* CALCULATION	* PART MOUZA PLAN
* F.A.R. CALCULATION	

PLANNER	SH. NO	1/1