

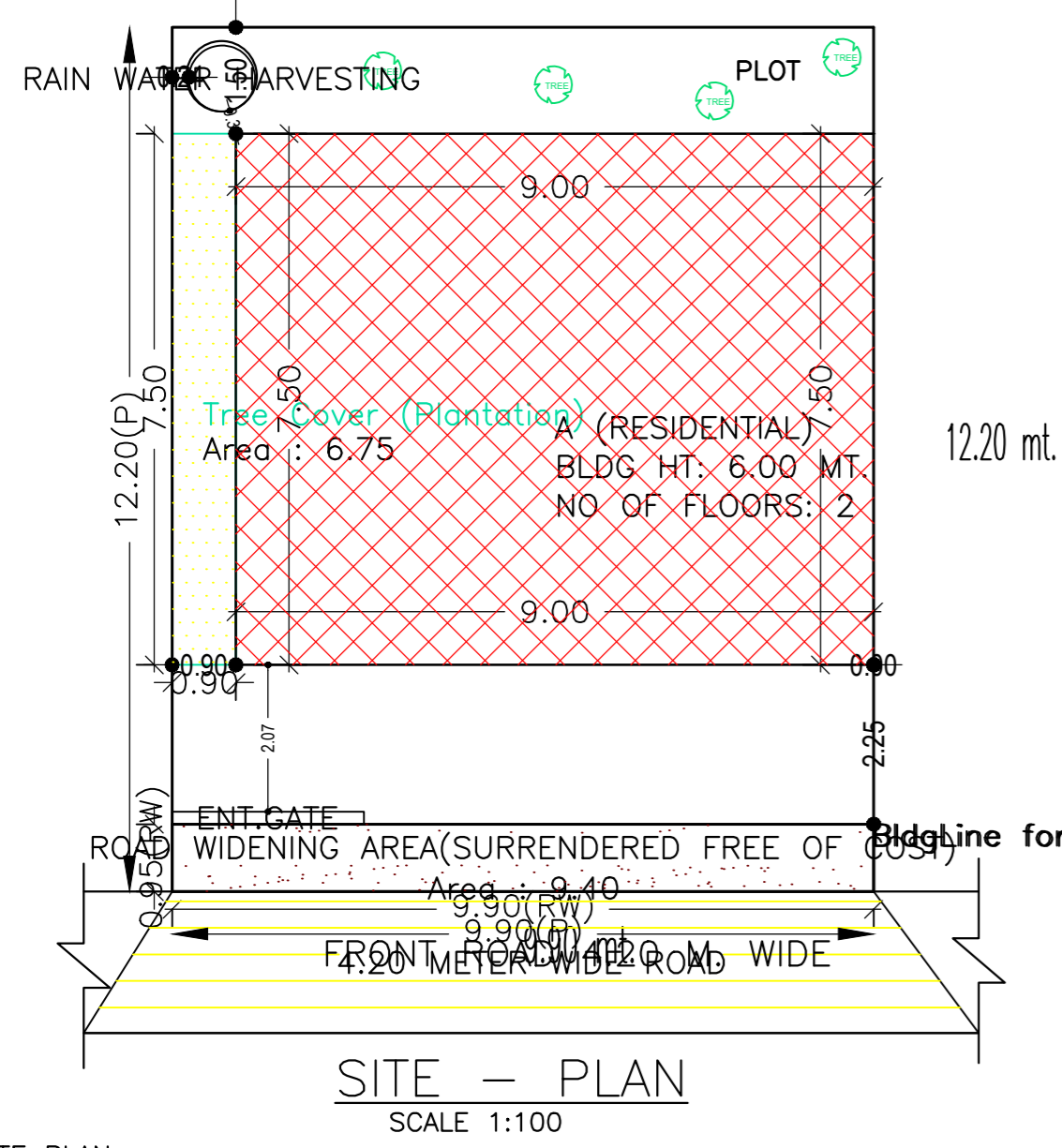

Proposal Basic Information	
Proposal File No.	MNAC/BP/0053/W10/2020
Owner Name	ARCHANA CHAUDHARY
Khata No	318
Plot No	4018
Village Name	Mango
Use	Residential
SubUse	Bungalow/ Dwelling / Non Apartment



Building USE/SUBUSE Details

Building Name	Building Use	Building SubUse	Building Structure
A (RESIDENTIAL)	Residential	Bungalow/ Dwelling / Non Apartment	Non-Highrise

AREA STATEMENT MANGO MUNICIPAL CORPORATION		VERSION NO.: 1.0.53
		VERSION DATE: 16/10/2020
<b>PROJECT DETAIL:</b>		
Region: JHARKHAND URBAN LOCAL BODIES	Plot Use: Residential	
District: EAST SINGHBHUM	Plot SubUse: Bungalow/ Dwelling / Non Apartment	
Authority: MANGO MUNICIPAL CORPORATION	PlotNearbyReligiousStructure: NA	
Inward_No: MNAC/BP/0053/W10/2020	Plot/SubPlot No: 4018	
Application Type: General Proposal	North: Plot No. - 4018	
Project Type: Building Permission	South: Plot No. - 4018	
Nature of Development: New	East: Plot No. - 4018	
Location of Development Area: Old Area	West: Road Width - 4.20	
<b>AREA DETAILS:</b>		
AREA OF PLOT (Minimum)	(A)	SQ.MT. 120.78
<b>Deduction for NetPlot Area</b>		
Surrender Free of Cost		9.41
Total		9.41
NET AREA OF PLOT(Gross Plot Area - Deduction from Gross Plot area)	(A-Deductions)	111.38
<b>Deduction for Balance Plot Area(from Gross Plot Area)</b>		
Surrender Free of Cost		9.41
Common Plot		6.75
Total		16.16
BALANCE AREA OF PLOT(Net Plot Area - Recreational/Amenity space)	(A-Deductions)	104.63
PLOT AREA FOR COVERAGE(Net Plot Area)	(A-Deductions)	111.38
Plot Area for FAR (Net Plot Area + RoadWidening Area)	(A-Deductions)	120.78
<b>COVERAGE CHECK</b>		
Permissible Coverage area ( 70.00 % )		77.97
Proposed Coverage Area ( 60.61 % )		67.50
Total Prop. Coverage Area ( 60.61 % )		67.50
Balance coverage area ( 9.40 % )		10.47
<b>FAR CHECK</b>		
Perm. FAR Area ( 1.50 )		181.17
Total Perm. FAR area		181.17
Residential FAR		67.50
Proposed FAR Area		76.44
Total Proposed FAR Area		76.44
Consumed FAR (Factor)		0.63
Balance FAR Area		104.73
<b>BUILT UP AREA CHECK</b>		
Total Proposed BuiltUp Area		135.00
ARCHITECT (Regd)	Chandrika Sharma	
ENGINEER (Regd)		
SUPERVISOR (Regd)		
OWNER (Regd)	ARCHANA CHAUDHARY	
DEVELOPMENT AUTHORITY		LOCAL BODY

Buildingwise Floor FAR Details

Floor Name	Building Name A (RESIDENTIAL)		Total	
	Proposed Built Up Area (Sq.mt.)	Proposed FAR Area (Sq.mt.)	Total Proposed Built Up Area (Sq.mt.)	Total FAR Area (Sq.mt.)
Ground Floor	67.50	8.94	67.50	8.94
First Floor	67.50	67.50	67.50	67.50
Terrace Floor	0.00	0.00	0.00	0.00
Total :	135.00	76.44	135.00	76.44

FAR & Tenement Details (Table 4c-1)

Building	No. of Same Bldg	Total Built Up Area (Sq.mt.)	Deductions (Area in Sq.mt.)		Proposed FAR Area (Sq.mt.)	Add Area In FAR (Sq.mt.)	Total FAR Area (Sq.mt.)	Total Consumed Additional FAR Area (Sq.mt.)	Tnmt (No.)
			Parking	Resi.					
A (RESIDENTIAL)	1	135.00	58.56	67.50	8.94	76.44	76.44	01	
Grand Total :	1	135.00	58.56	67.50	8.94	76.44	76.44	01	

COLOR INDEX	
PLOT BOUNDARY	
ABUTTING ROAD	
PROPOSED CONSTRUCTION	
COMMON PLOT	
ROAD WIDENING AREA	
EXISTING (To be retained)	
EXISTING (To be demolished)	

LTP NAME AND SIGNATURE	STRUCTURAL ENG'S NAME AND SIGNATURE	BUILDER NAME AND SIGNATURE	DIGITAL SIGNATURE
Chandrika Sharma MNAC/DFTMN/0017/2017			

Proposal Basic Information	
Proposal File No.	MNAC/BP/0053/W10/2020
Owner Name	ARCHANA CHAUDHARY
Khata No	318
Plot No	4018
Village Name	Mango
Use	Residential
SubUse	Bungalow/ Dwelling / Non Apartment

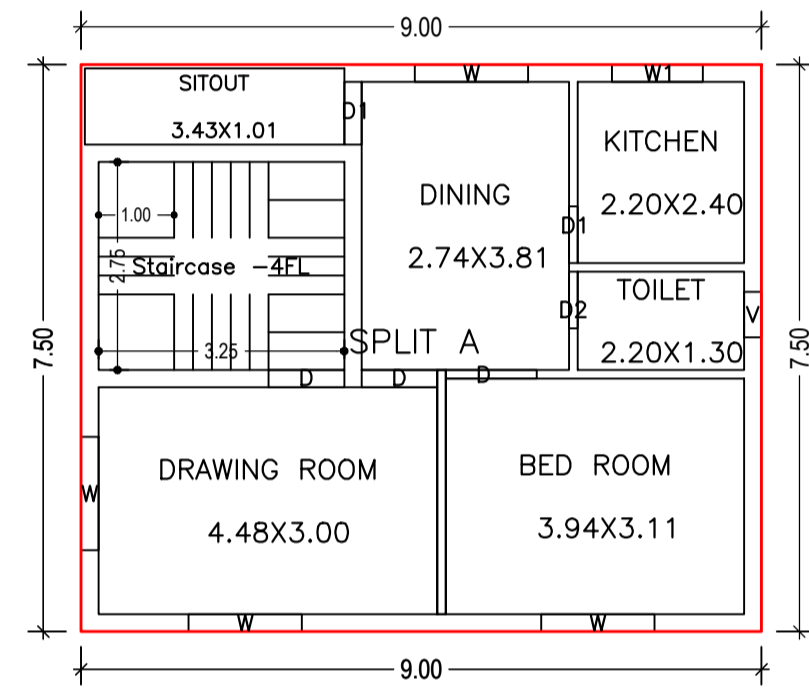

FIRST FLOOR PLAN  
(Proposed)  
(SCALE 1:100)

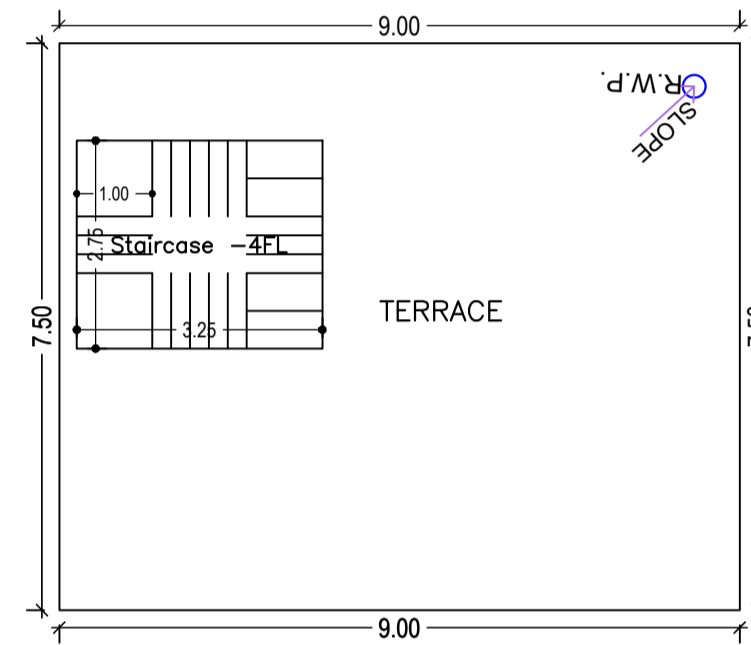

TERRACE FLOOR PLAN  
(SCALE 1:100)

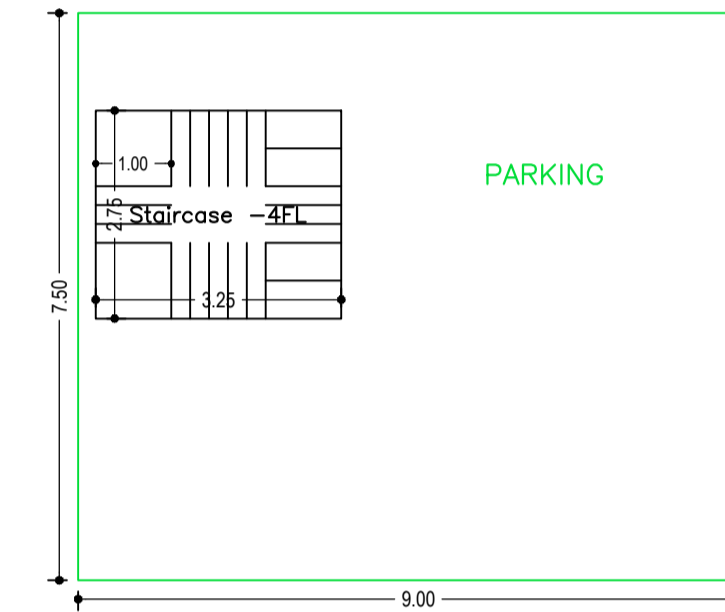

GROUND FLOOR PLAN  
(SCALE 1:100)

UnitBUA Table for Building :A (RESIDENTIAL)

FLOOR	Name	UnitBUA Type	UnitBUA Area	Carpet Area	No. of Rooms	No. of Tenement
FIRST FLOOR PLAN	SPLIT A	FLAT	49.72	49.35	6	1
Total:	-	-	49.72	49.35	6	1

Building :A (RESIDENTIAL)

Floor Name	Total Built Up Area (Sq.mt.)	Deductions (Area in Sq.mt.)		Proposed FAR Area (Sq.mt.)	Add Area in FAR (Sq.mt.)	Total FAR Area (Sq.mt.)	Total Consumed Additional FAR Area (Sq.mt.)	Trmt (No.)
		Parking	Resi.					
Ground Floor	67.50	58.56	0.00	8.94	8.94	8.94	0.00	01
First Floor	67.50	0.00	67.50	0.00	67.50	67.50	0.00	01
Terrace Floor	0.00	0.00	0.00	0.00	0.00	0.00	0.00	00
Total:	135.00	58.56	67.50	8.94	76.44	76.44	0.00	01
Total Number of Same Buildings :	1							
Total :	135.00	58.56	67.50	8.94	76.44	76.44	0.00	01

SCHEDULE OF DOOR:

BUILDING NAME	NAME	LENGTH	HEIGHT	NOS
A (RESIDENTIAL)	D2	0.75	2.10	01
A (RESIDENTIAL)	D1	0.75	2.10	01
A (RESIDENTIAL)	D1	0.83	2.10	01
A (RESIDENTIAL)	D	1.00	2.10	02
A (RESIDENTIAL)	D	1.20	2.10	01

SCHEDULE OF WINDOW/VENTILATION:

BUILDING NAME	NAME	LENGTH	HEIGHT	NOS
A (RESIDENTIAL)	V	0.60	0.75	01
A (RESIDENTIAL)	W1	1.20	1.20	01
A (RESIDENTIAL)	W	1.50	1.20	04

LTP NAME AND SIGNATURE	STRUCTURAL ENG'S NAME AND SIGNATURE	BUILDER NAME AND SIGNATURE	DIGITAL SIGNATURE
Chandrika Sharma MNAC/DFTMN/0017/2017			

Proposal Basic Information	
Proposal File No.	MNAC/BP/0053/W10/2020
Owner Name	ARCHANA CHAUDHARY
Khata No	318
Plot No	4018
Village Name	Mango
Use	Residential
SubUse	Bungalow/ Dwelling / Non Apartment

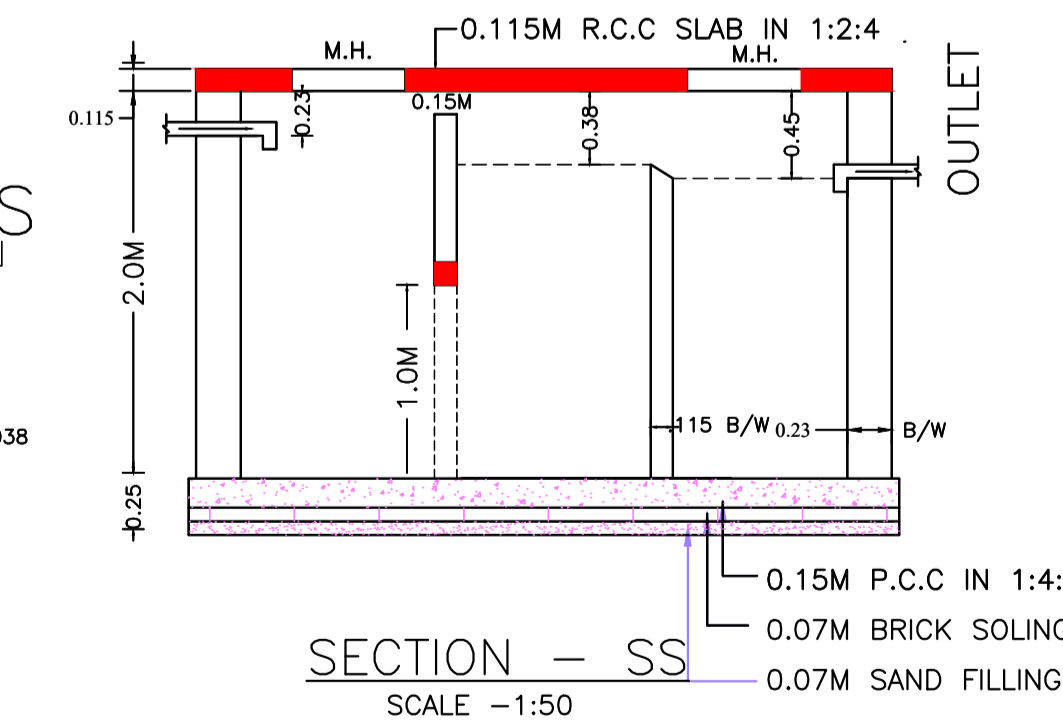
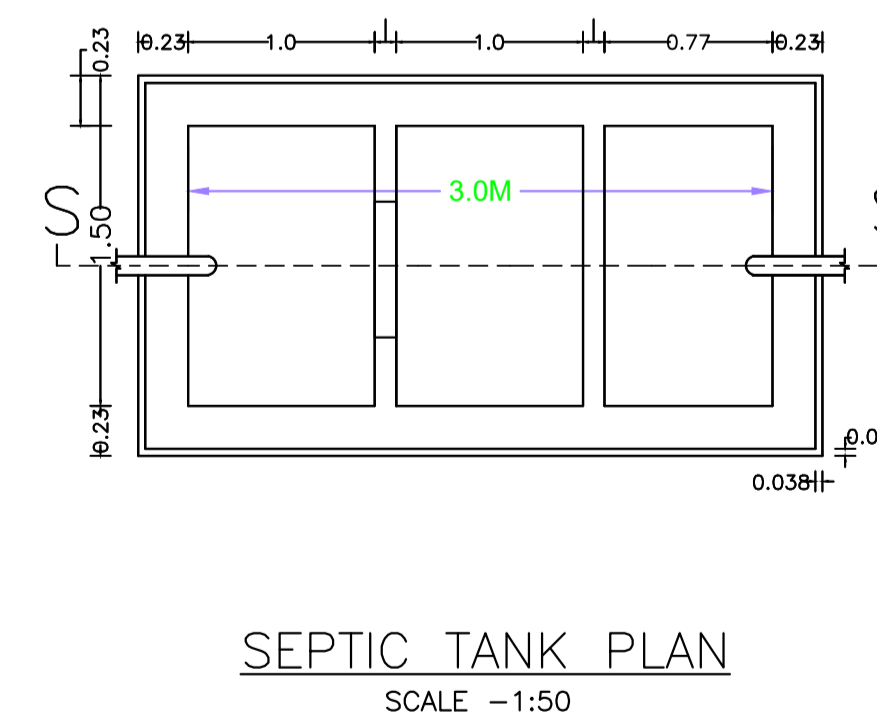
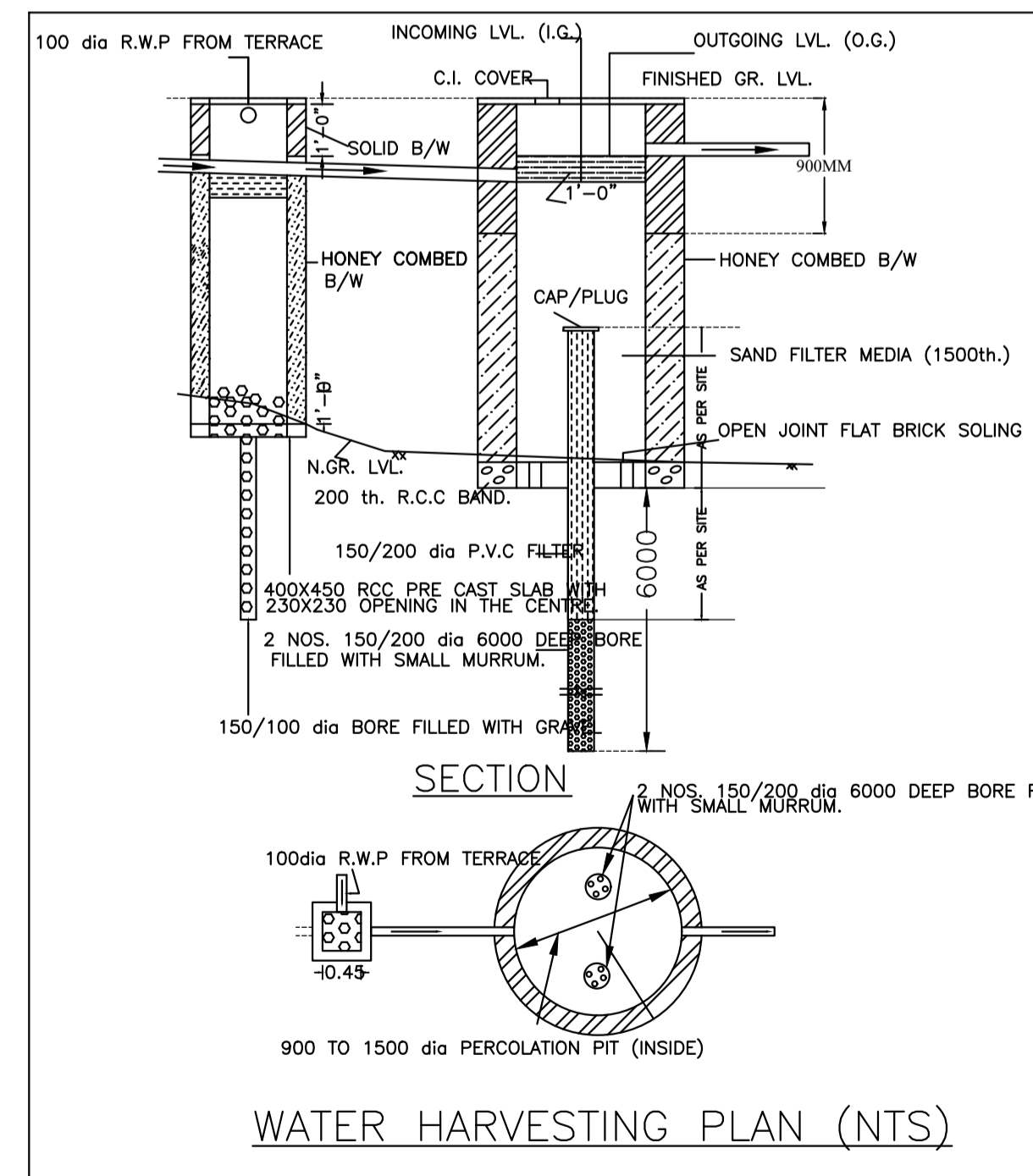
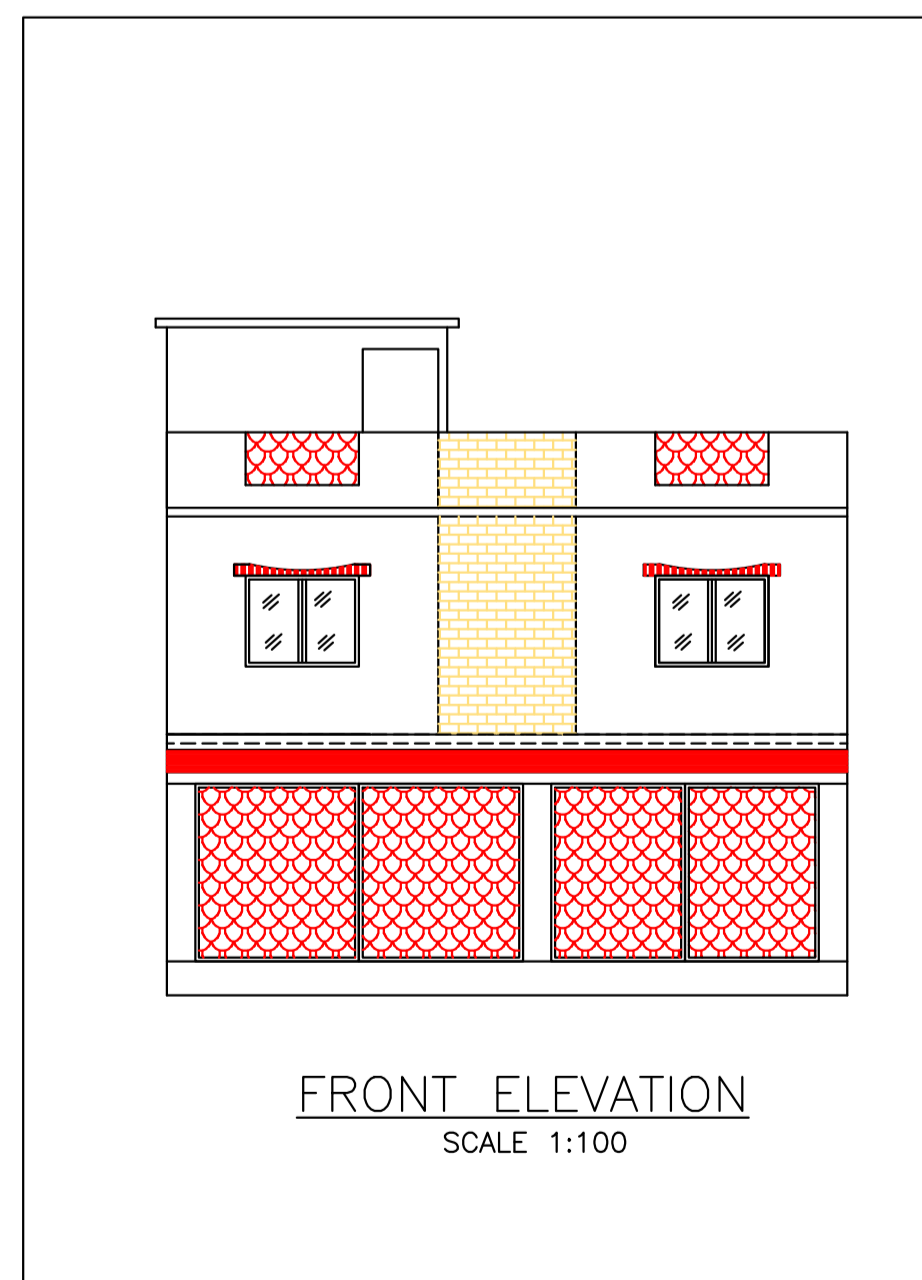
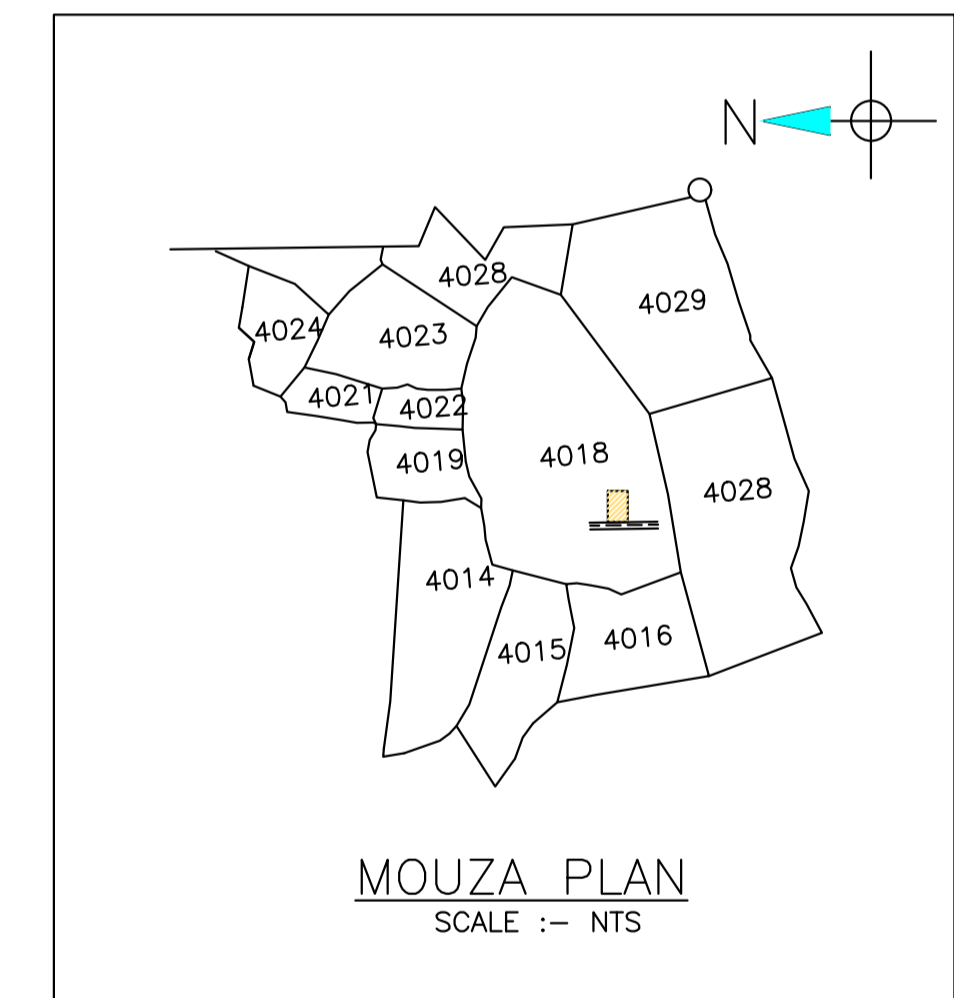
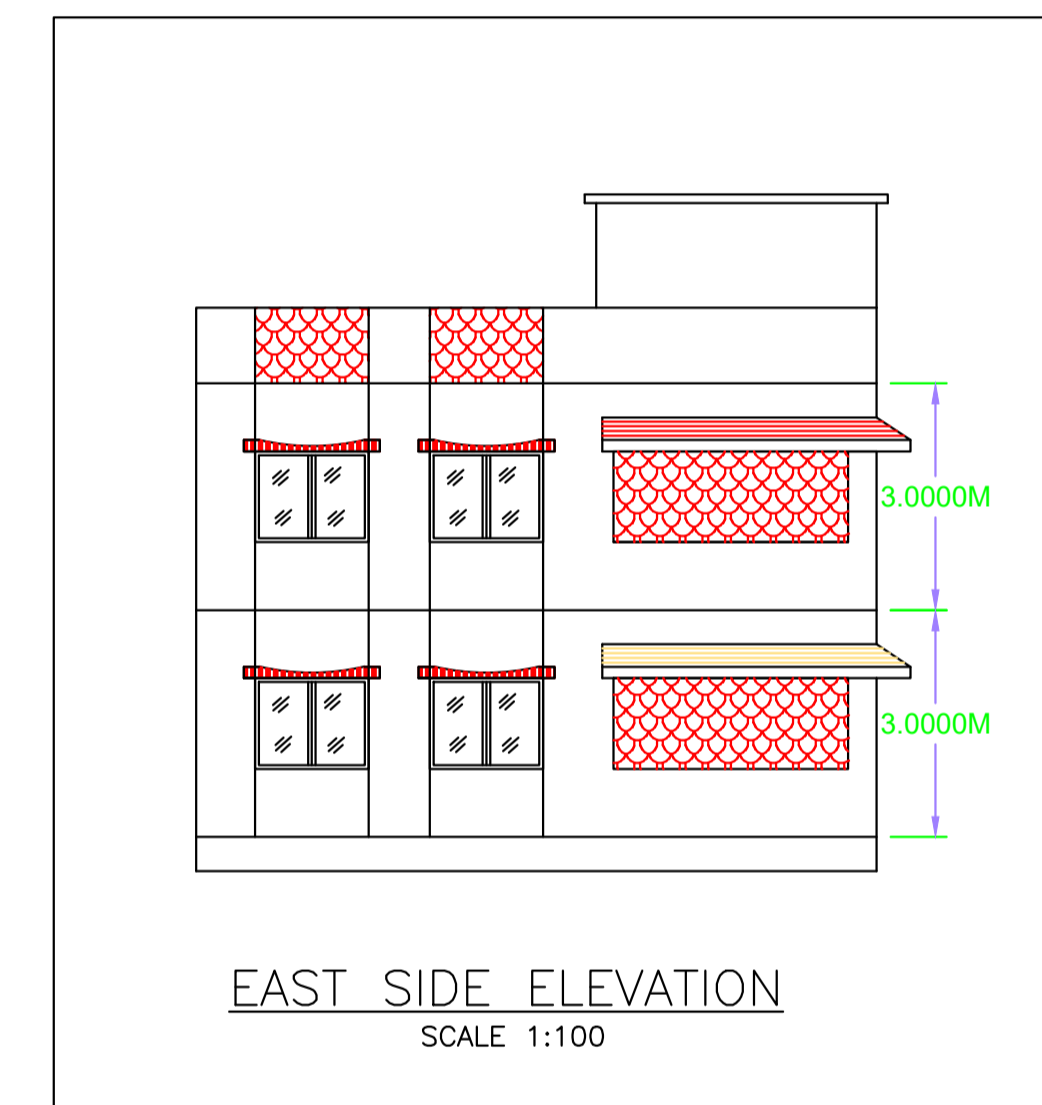
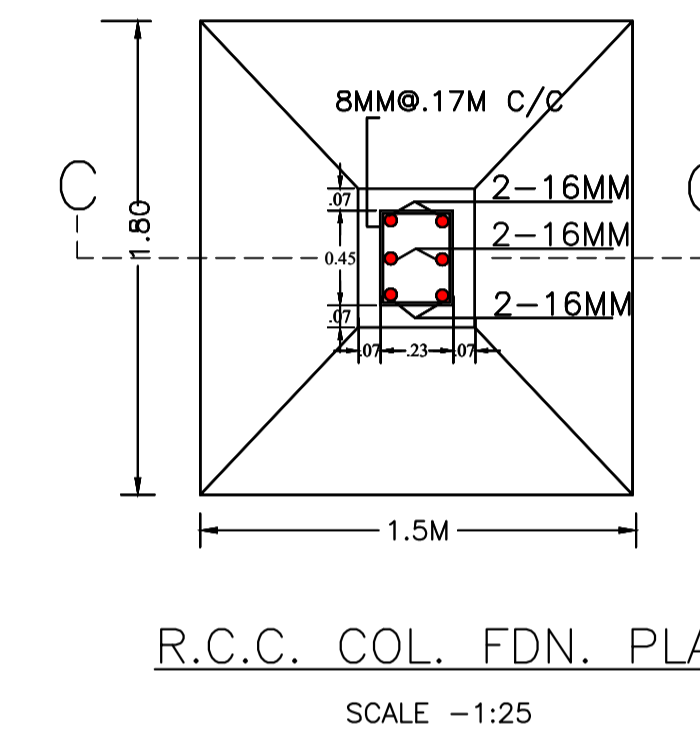
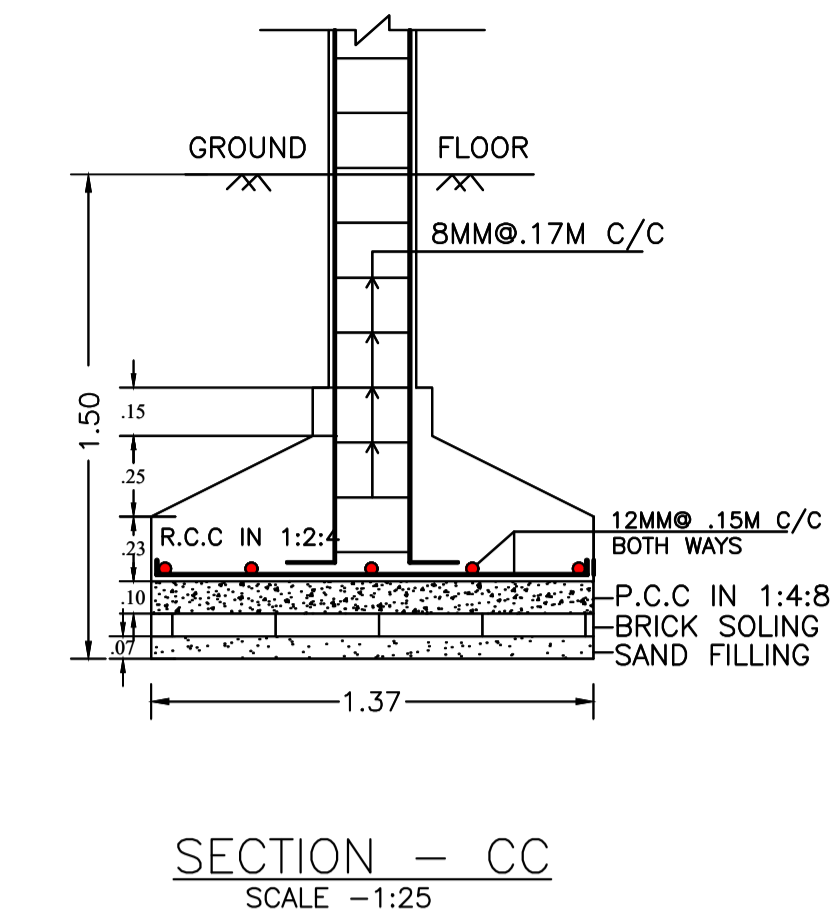
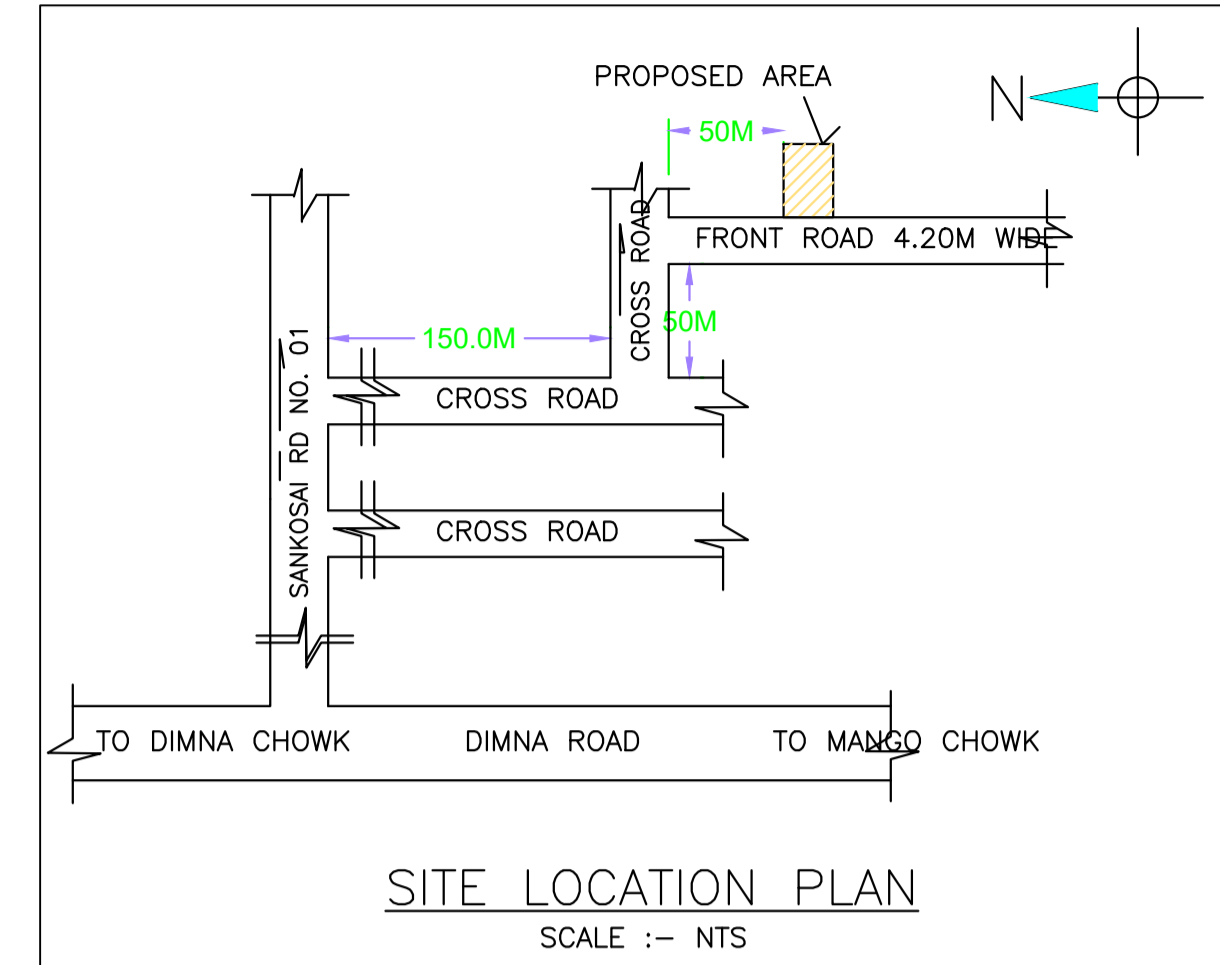
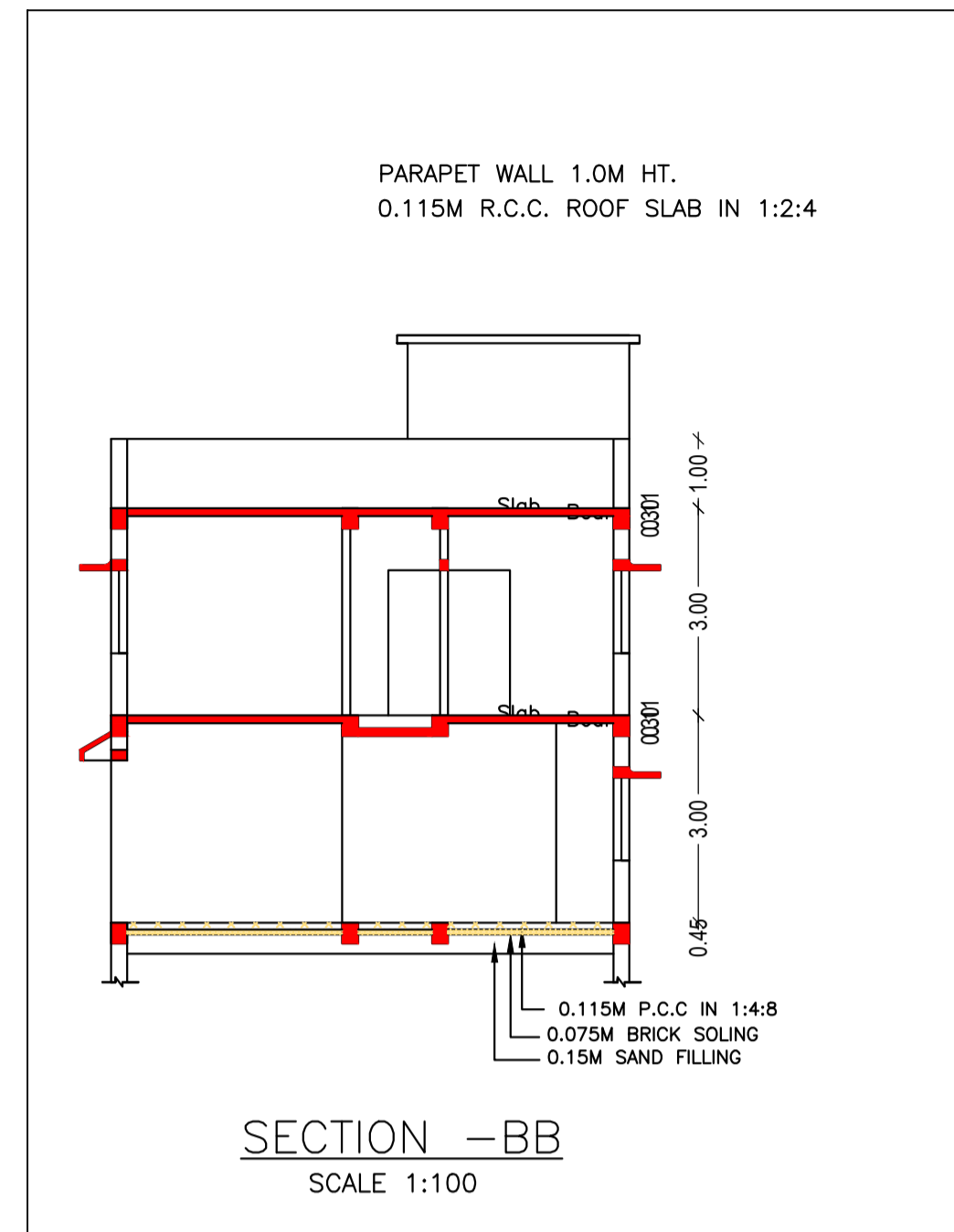
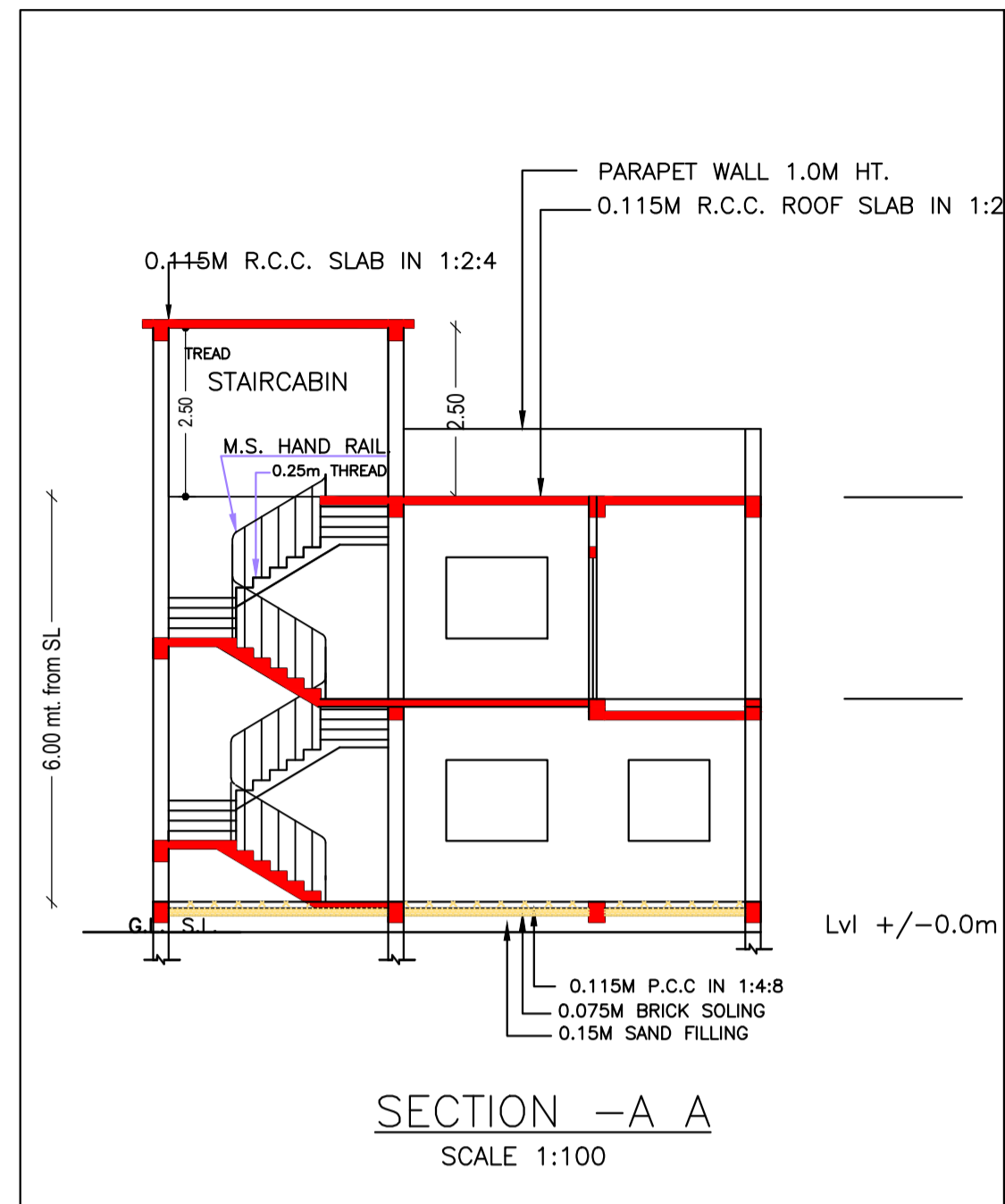

LTP NAME AND SIGNATURE	STRUCTURAL ENG'S NAME AND SIGNATURE	BUILDER NAME AND SIGNATURE	DIGITAL SIGNATURE
Chandrika Sharma MNAC/DFTMN/0017/2017			