

site plan

Building USE/SUBUSE Details

Building Name	Building Use	Building SubUse	Building Structure
RESIDENTIAL (BUILDING)	Residential	Bungalow/ Dwelling / Non Apartment	Non-Highrise

Proposal Basic Information

Proposal File No	MNAC/BP/0058/W08/2020
Owner Name	MUMTAZ ALAM ANSARI
Khata No	1019
Plot No	1886
Village Name	Pardih
Use	Residential
SubUse	Bungalow/ Dwelling / Non Apartment

FAR & Tenement Details (Table 4c-1)

Building	No. of Same Bldg	Total Built Up Area (Sq.mt.)	Deductions (Area in Sq.mt.)		Proposed FAR Area (Sq.mt.)	Total FAR Area (Sq.mt.)	Total Consumed Additional FAR Area (Sq.mt.)	Tnmt (No.)
			Parking	Resi.				
RESIDENTIAL (BUILDING)	1	317.31	23.25		294.06	294.06	294.06	01
Grand Total :	1	317.31	23.25		294.06	294.06	294.06	01

AREA STATEMENT MANGO MUNICIPAL CORPORATION	VERSION NO.: 1.0.62	
	VERSION DATE: 16/10/2020	
PROJECT DETAIL:		
Region: JHARKHAND URBAN LOCAL BODIES	Plot Use: Residential	
District: EAST SINGHBHUM	Plot SubUse: Bungalow/ Dwelling / Non Apartment	
Authority: MANGO MUNICIPAL CORPORATION	PlotNearbyReligiousStructure: NA	
Inward_No: MNAC/BP/0058/W08/2020	Plot/SubPlot No: 1886	
Application Type: General Proposal	North: Plot No. - A HAQUE	
Project Type: Building Permission	South: Road Width - 2.50	
Nature of Development: New	East: Road Width - 6.20	
Location of Development Area: Old Area	West: Plot No. - MUMTAZ ALAM ANSARI	
AREA DETAILS:	SQ.MT.	
AREA OF PLOT (Minimum)	(A)	167.26
NET AREA OF PLOT(Gross Plot Area - Deduction from Gross Plot area)	(A-Deductions)	167.26
Deduction for Balance Plot Area(from Gross Plot Area)		
Common Plot		16.65
Total		16.65
BALANCE AREA OF PLOT(Net Plot Area - Recreational/Amenity space)	(A-Deductions)	150.61
PLOT AREA FOR COVERAGE(Net Plot Area)	(A-Deductions)	167.26
Plot Area for FAR (Net Plot Area + Road Widening Area)	(A-Deductions)	167.26
COVERAGE CHECK		
Permissible Coverage area ( 70.00 % )		117.08
Proposed Coverage Area ( 63.24 % )		105.77
Total Prop. Coverage Area ( 63.24 % )		105.77
Balance coverage area ( 6.76 % )		11.31
FAR CHECK		
Perm. FAR Area ( 2.50 )		418.15
Total Perm. FAR area		418.15
Residential FAR		294.06
Proposed FAR Area		294.06
Total Proposed FAR Area		294.06
Consumed FAR (Factor)		1.76
Balance FAR Area		124.09
BUILT UP AREA CHECK		
Total Proposed BuiltUp Area		317.31
ARCHITECT (Regd)		NIKHIL SHUKLA
ENGINEER (Regd)		
SUPERVISOR (Regd)		
OWNER (Regd)		MUMTAZ ALAM ANSARI
DEVELOPMENT AUTHORITY		LOCAL BODY

COLOR INDEX	
PLOT BOUNDARY	Black
ABUTTING ROAD	Green
PROPOSED CONSTRUCTION	Red
COMMON PLOT	Yellow
ROAD WIDENING AREA	Blue
EXISTING (To be retained)	Blue
EXISTING (To be demolished)	Yellow

Buildingwise Floor FAR Details

Floor Name	Building Name		Total	
	Proposed Built Up Area (Sq.mt.)	Proposed FAR Area (Sq.mt.)	Total Proposed Built Up Area (Sq.mt.)	Total FAR Area (Sq.mt.)
Ground And Parking Floor	105.77	82.52	105.77	82.52
First Floor	105.77	105.77	105.77	105.77
Second Floor	105.77	105.77	105.77	105.77
Terrace Floor	0.00	0.00	0.00	0.00
Total :	317.31	294.06	317.31	294.06

LTP NAME AND SIGNATURE	STRUCTURAL ENG'S NAME AND SIGNATURE	SEAL AND SIGNATURE	OWNER'S NAME AND SIGNATURE
NIKHIL SHUKLA MNAC/ARC/0002/2018			

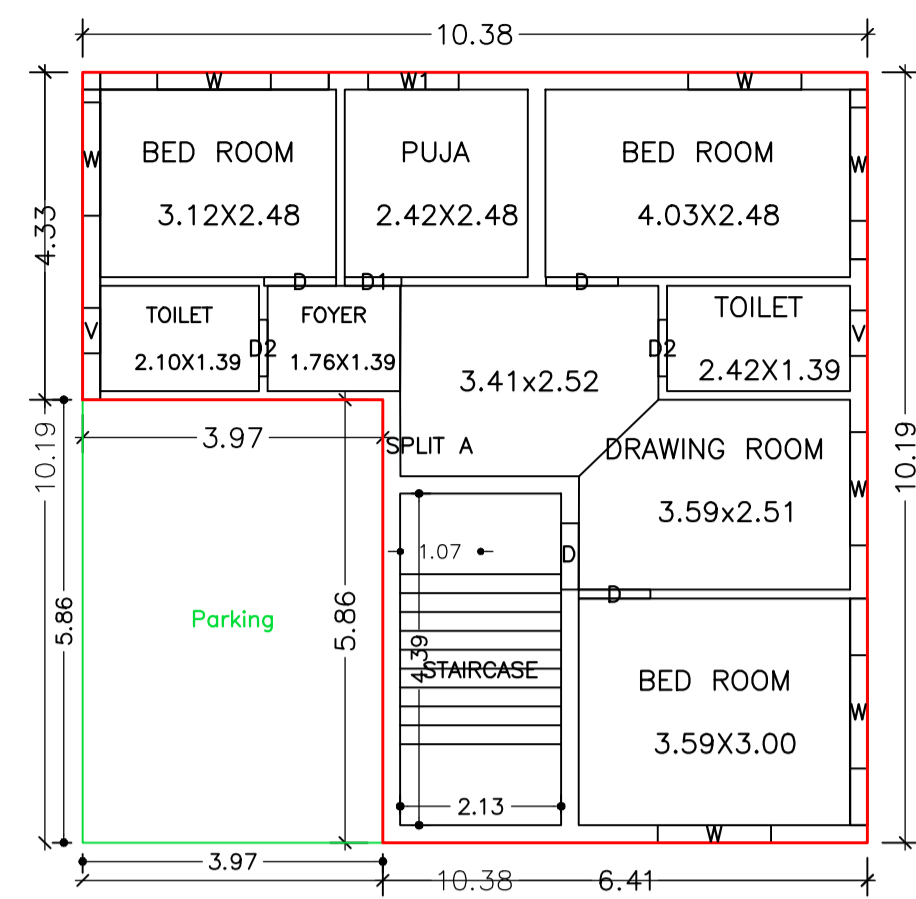

GROUND AND PARKING FLOOR PLAN (Proposed) (SCALE 1:100)

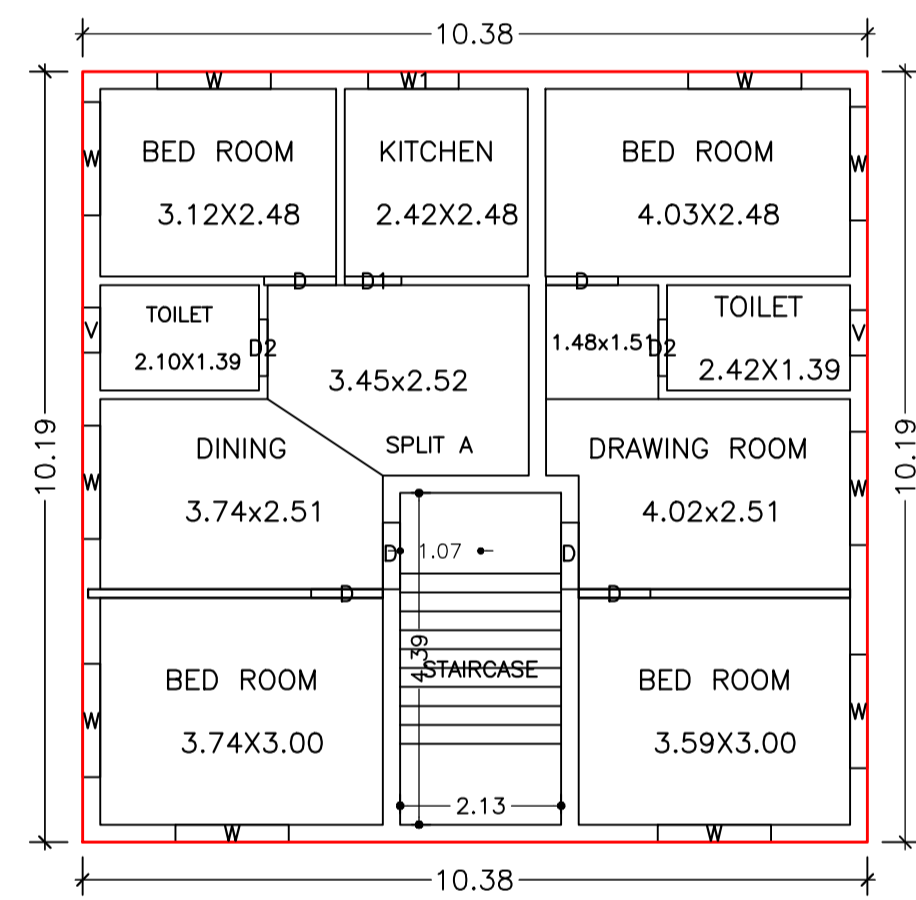

FIRST FLOOR PLAN (Proposed) (SCALE 1:100)

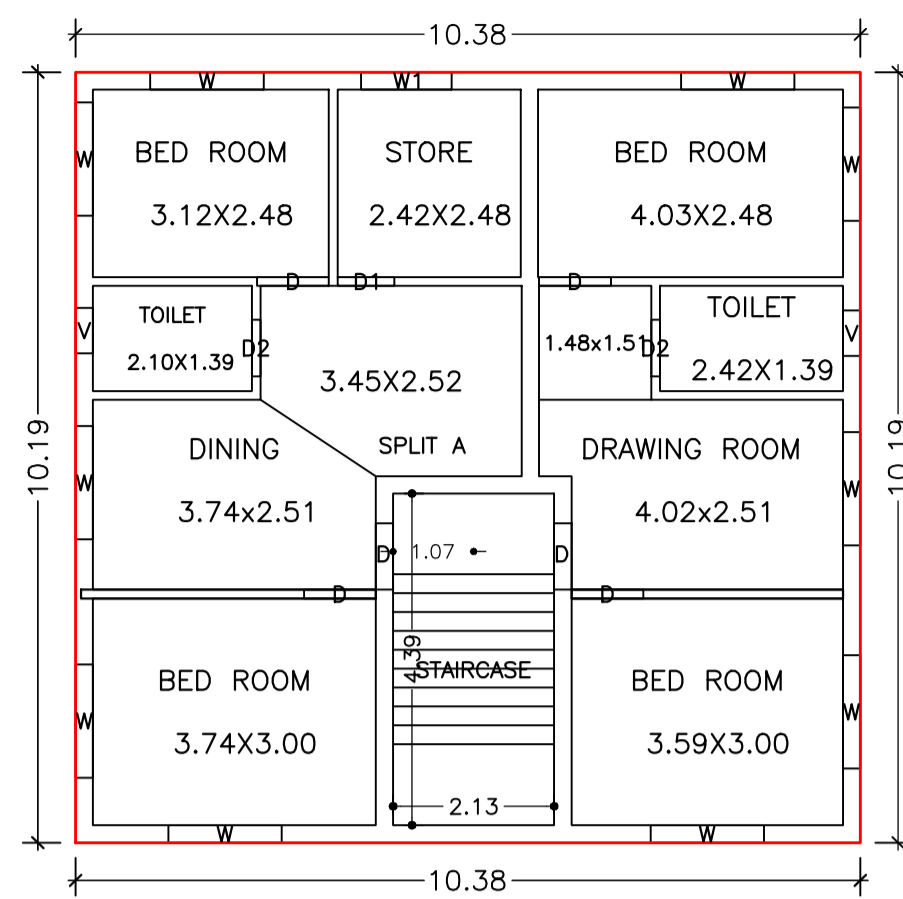

SECOND FLOOR PLAN (Proposed) (SCALE 1:100)

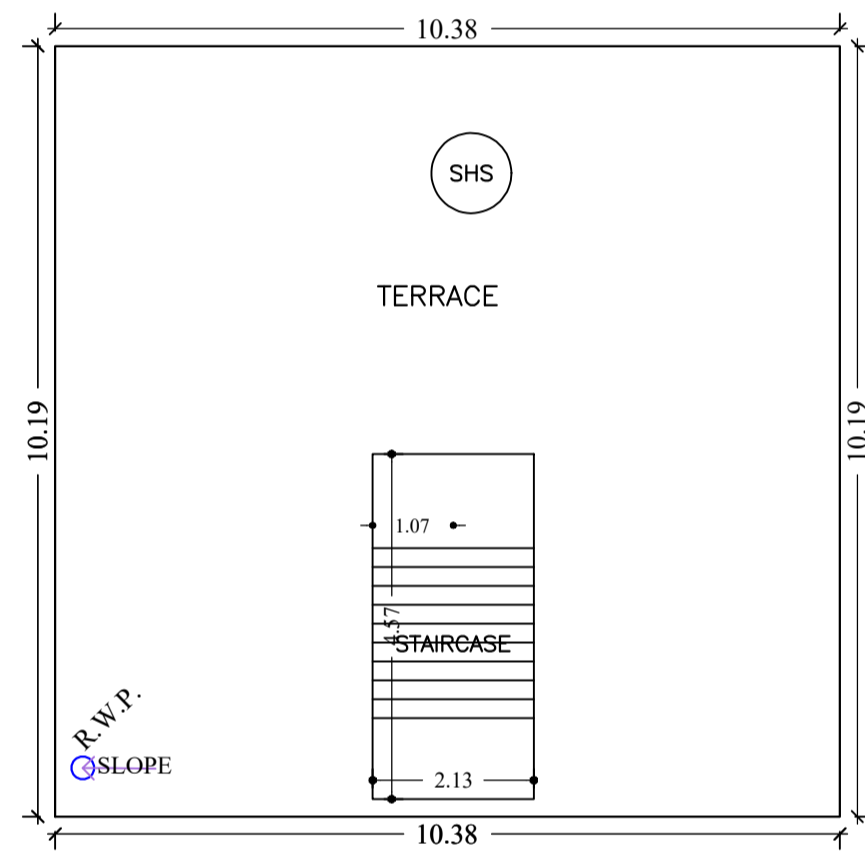

TERRACE FLOOR PLAN (SCALE 1:100)

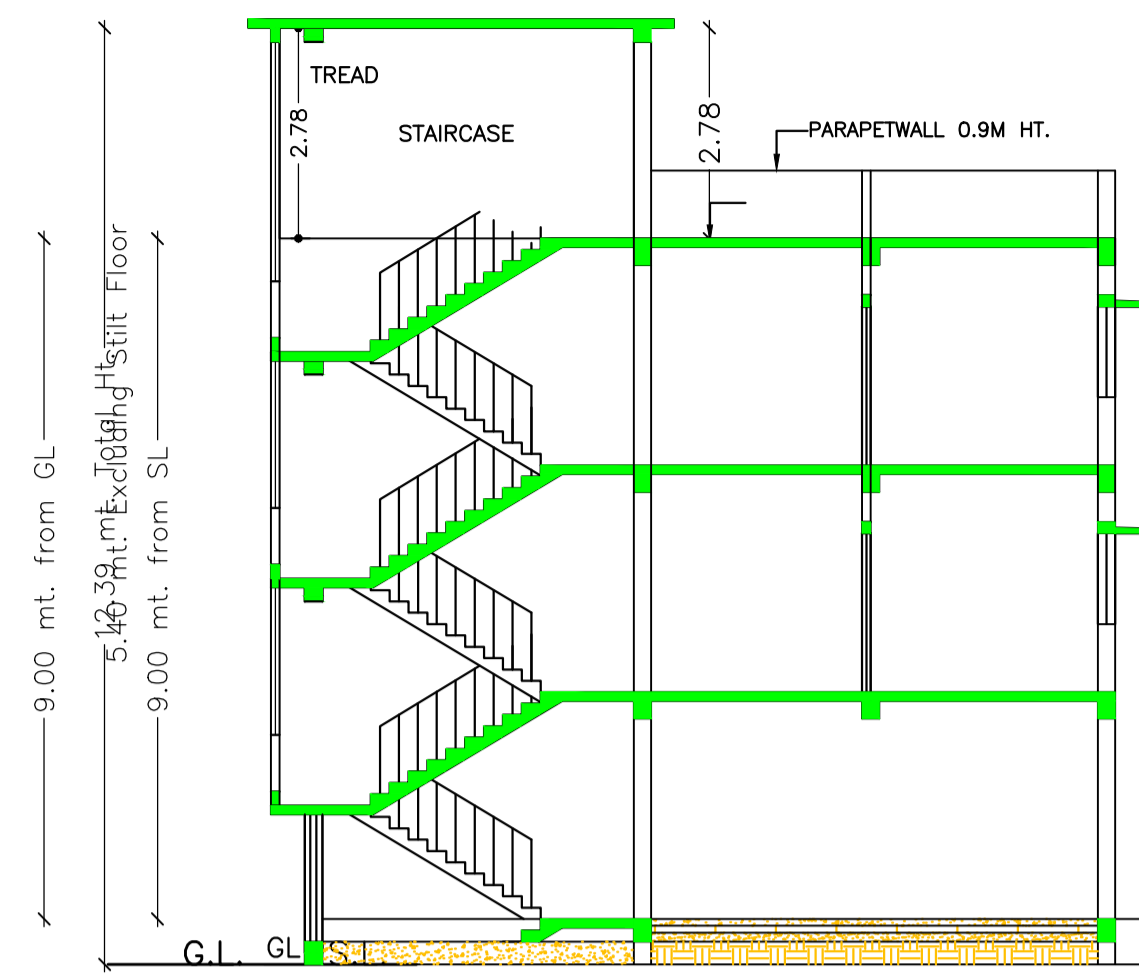

SECTION - AA SCALE 1:100

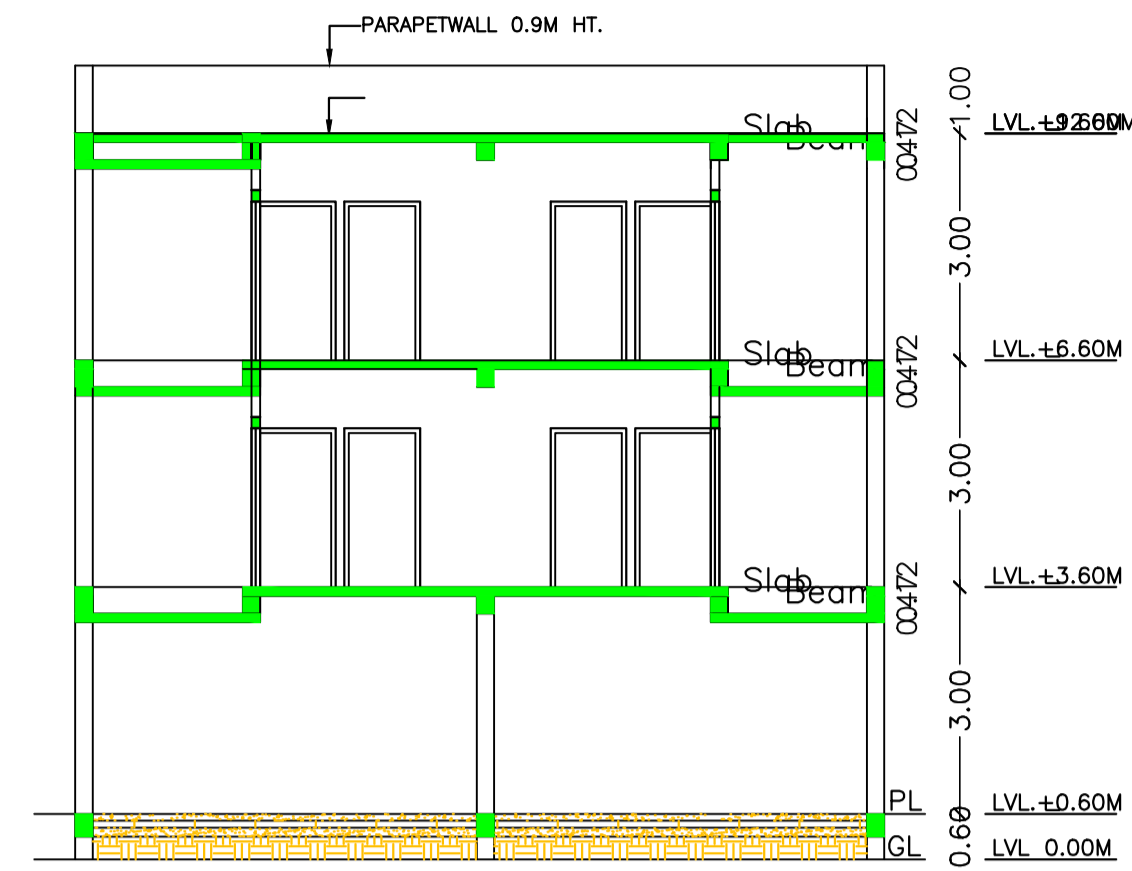

SECTION - BB SCALE 1:100

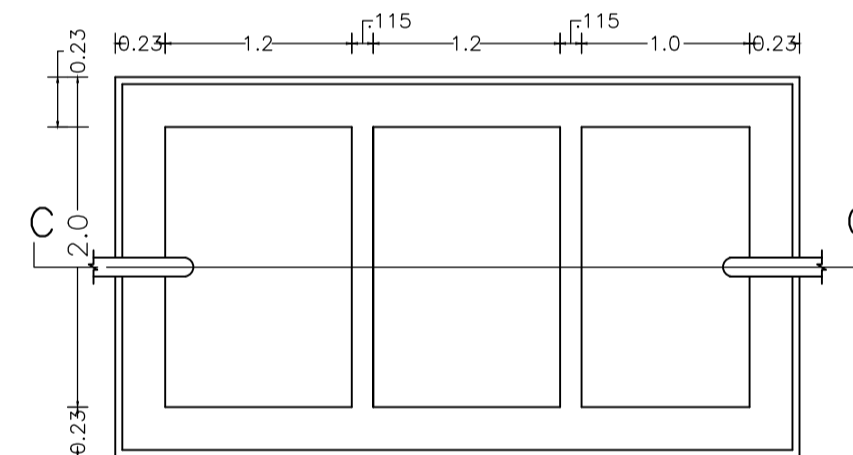

SEPTIC TANK PLAN SCALE - 1:50

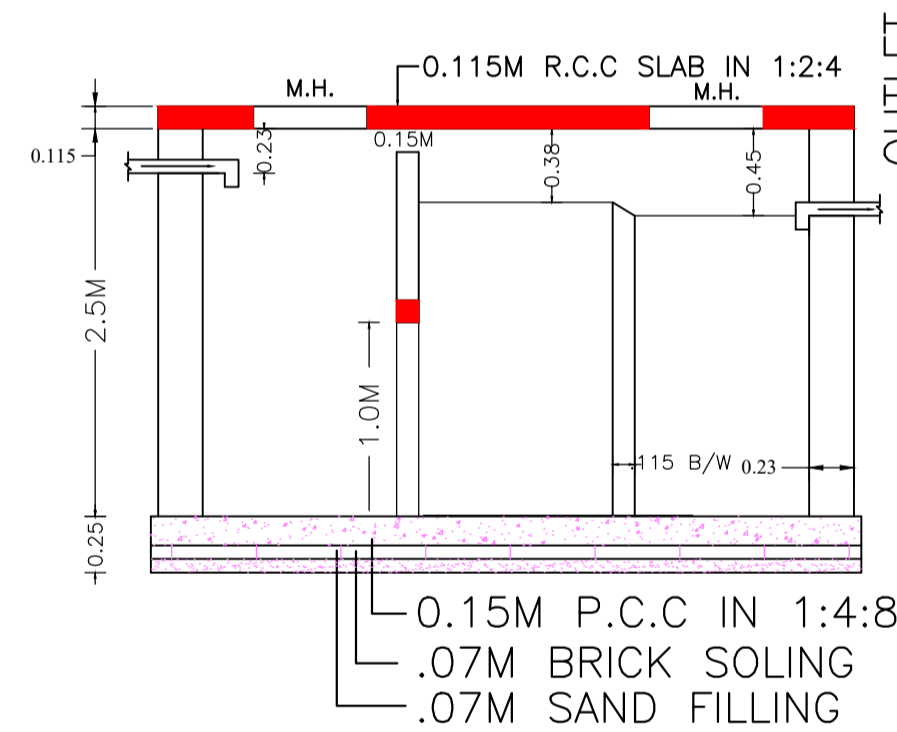

SECTION - SS SCALE - 1:50



MOUZA PLAN (NTS)

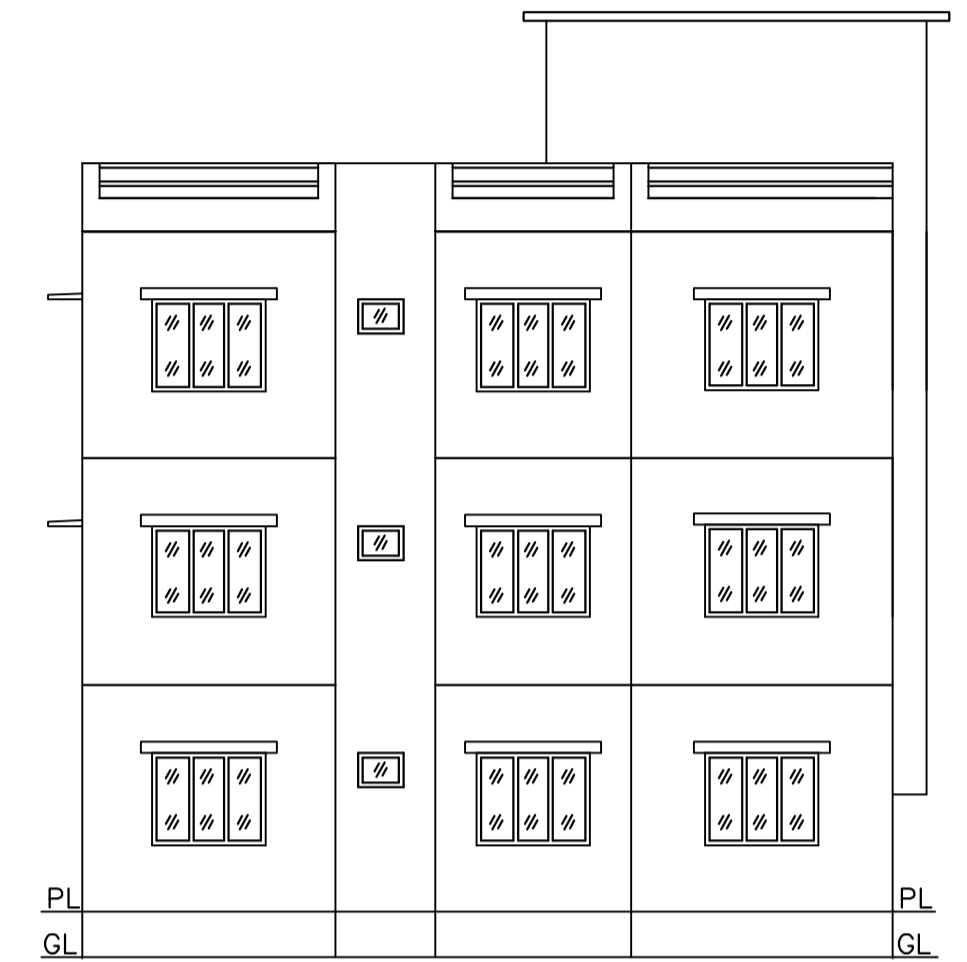

SOUTH SIDE ELEVATION SCALE 1:100

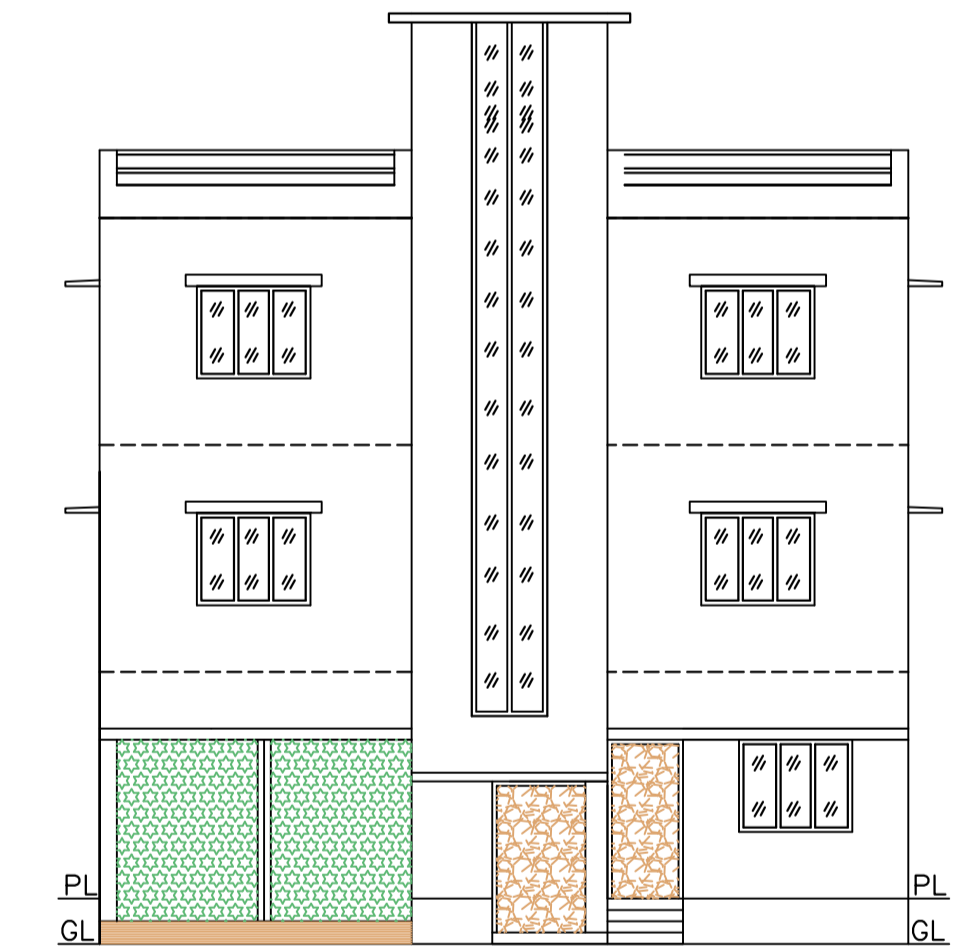

FRONT ELEVATION SCALE 1:100

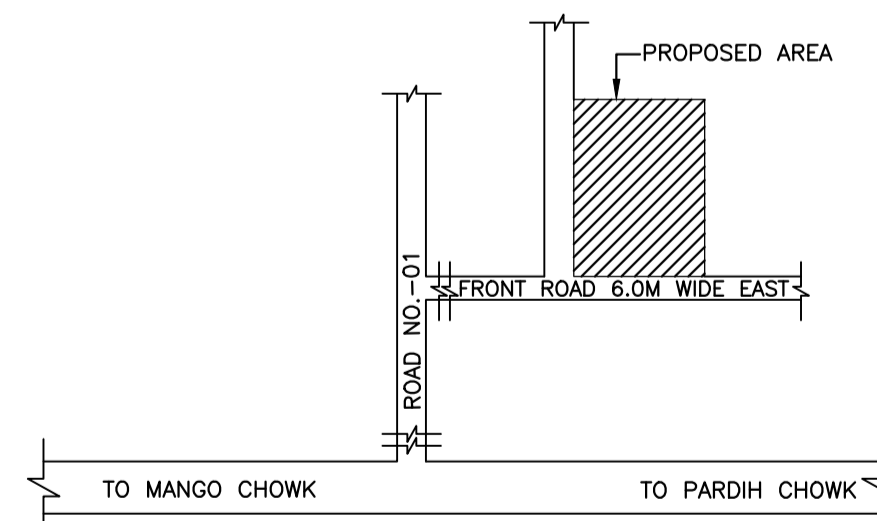

SITE LOCATION PLAN (NTS)

Building :RESIDENTIAL (BUILDING)

Floor Name	Total Built Up Area (Sq.mt.)	Deductions (Area in Sq.mt.)		Proposed FAR Area (Sq.mt.)	Total FAR Area (Sq.mt.)	Total Consumed Additional FAR Area (Sq.mt.)	Tnmt (No.)
		Parking	Resi.				
Ground And Parking Floor	105.77	23.25	82.52	82.52	82.52		01
First Floor	105.77	0.00	105.77	105.77	105.77		00
Second Floor	105.77	0.00	105.77	105.77	105.77		00
Terrace Floor	0.00	0.00	0.00	0.00	0.00		00
Total :		23.25	294.06	294.06	294.06		01
Total Number of Same Buildings :	1						
Total :	317.31	23.25	294.06	294.06	294.06		01

SCHEDULE OF DOOR:

BUILDING NAME	NAME	LENGTH	HEIGHT	NOS
RESIDENTIAL (BUILDING)	D2	0.75	2.10	06
RESIDENTIAL (BUILDING)	D1	0.75	2.10	03
RESIDENTIAL (BUILDING)	D	0.88	2.10	05
RESIDENTIAL (BUILDING)	D	0.95	2.10	11

SCHEDULE OF WINDOW/VENTILATION:

BUILDING NAME	NAME	LENGTH	HEIGHT	NOS
RESIDENTIAL (BUILDING)	V	0.60	0.90	06
RESIDENTIAL (BUILDING)	W1	1.20	1.20	03
RESIDENTIAL (BUILDING)	W	1.50	1.20	

UnitBUA Table for Building :RESIDENTIAL (BUILDING)

FLOOR	Name	UnitBUA Type	UnitBUA Area	Carpet Area	No. of Rooms
FIRST FLOOR PLAN	SPLIT A	FLAT	294.06	289.49	8
	SPLIT A	FLAT	0.00	0.00	9
	SPLIT A	FLAT	0.00	0.00	0
SECOND FLOOR PLAN	SPLIT A	FLAT	0.00	0.00	9
Total:	-	-	294.06	289.49	26

LTP NAME AND SIGNATURE	STRUCTURAL ENG'S NAME AND SIGNATURE	SI/BUA/DERNAME AND SIGNATURE	DURABLE SIGNATURE
NIKHIL SHUKLA MNAAC/ARC/0002/2018			

Proposal Basic Information	
Proposal File No.	MNAC/BP/0058/W08/2020
Owner Name	MUMTAZ ALAM ANSARI
Khata No	1019
Plot No	1886
Village Name	Pardih
Use	Residential
SubUse	Bungalow/ Dwelling / Non Apartment

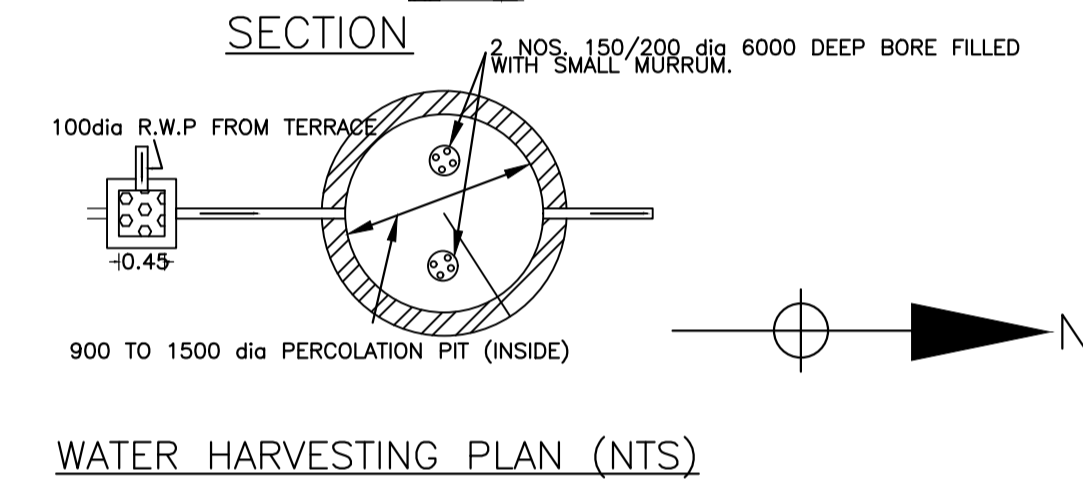
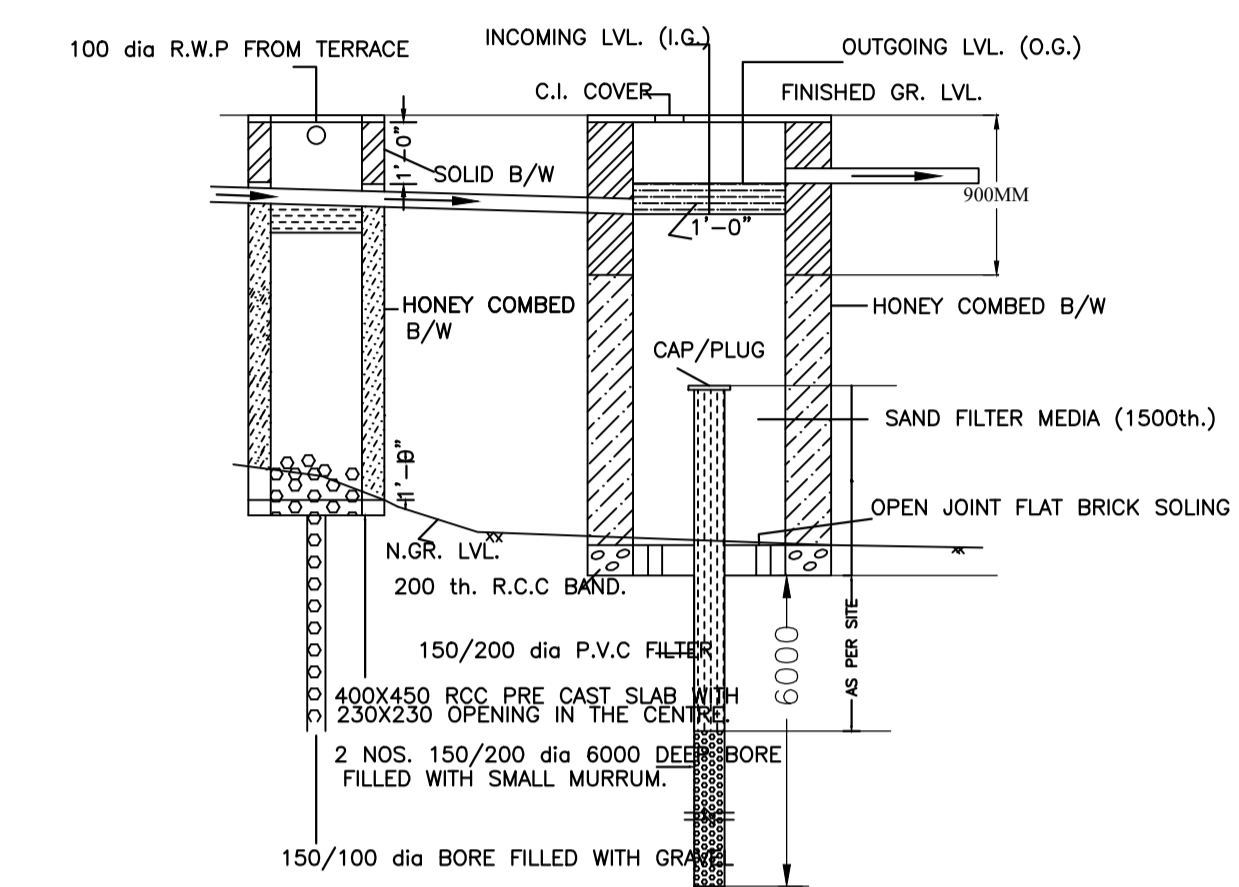

SECTION  
WATER HARVESTING PLAN (NTS)

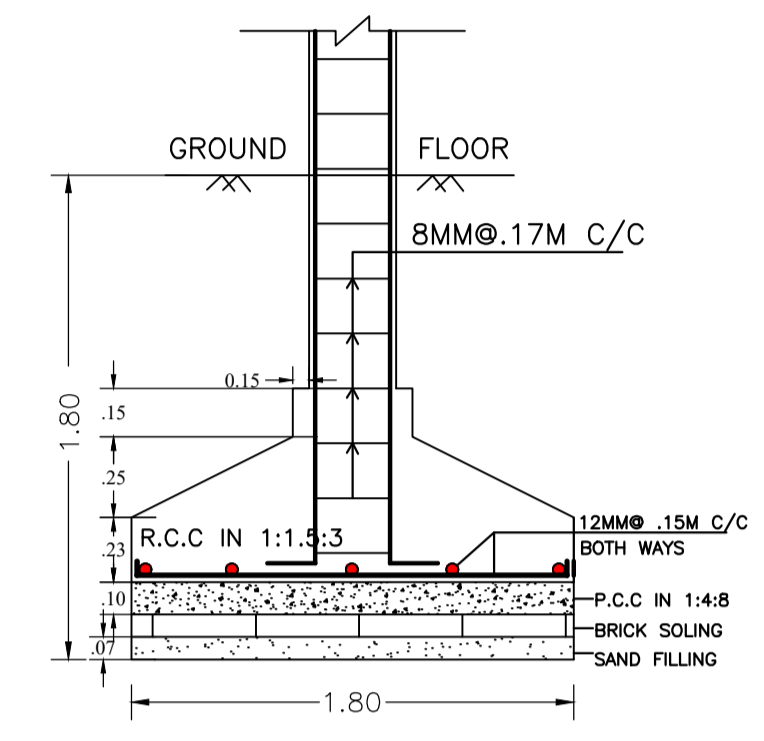

SECTION - CC  
SCALE - 1:25

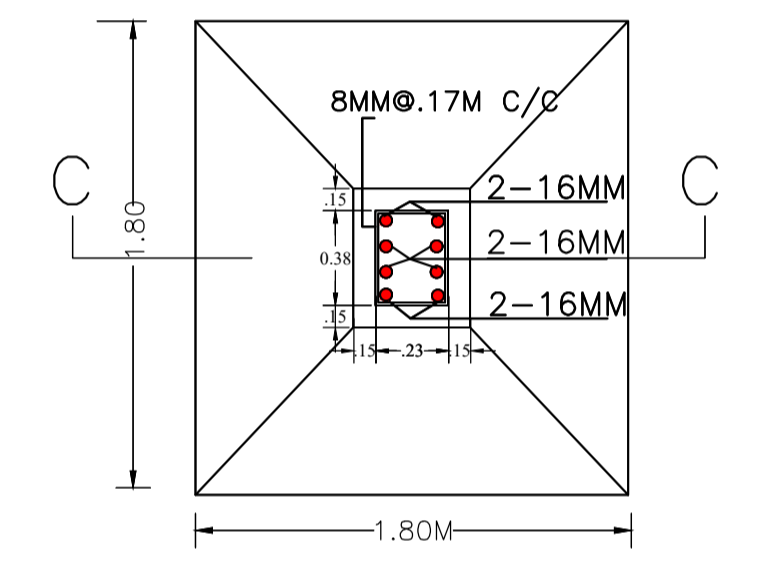

R.C.C. COL. FDN. PLAN  
SCALE - 1:25

LTP NAME AND SIGNATURE	STRUCTURAL ENG'S NAME AND SIGNATURE	DESIGNER NAME AND SIGNATURE	REAL SIGNATURE
NIKHIL SHUKLA MNAC/ARC/0002/2018			

