

Proposal Basic Information	
Proposal File No.	MNAC/BI/0016/W/10/2020
Owner Name	ASHISH KUMAR
Khata No	232
Plot No	3298
Village Name	Mango
Use	Residential
SubUse	Bungalow/ Dwelling / Non Apartment

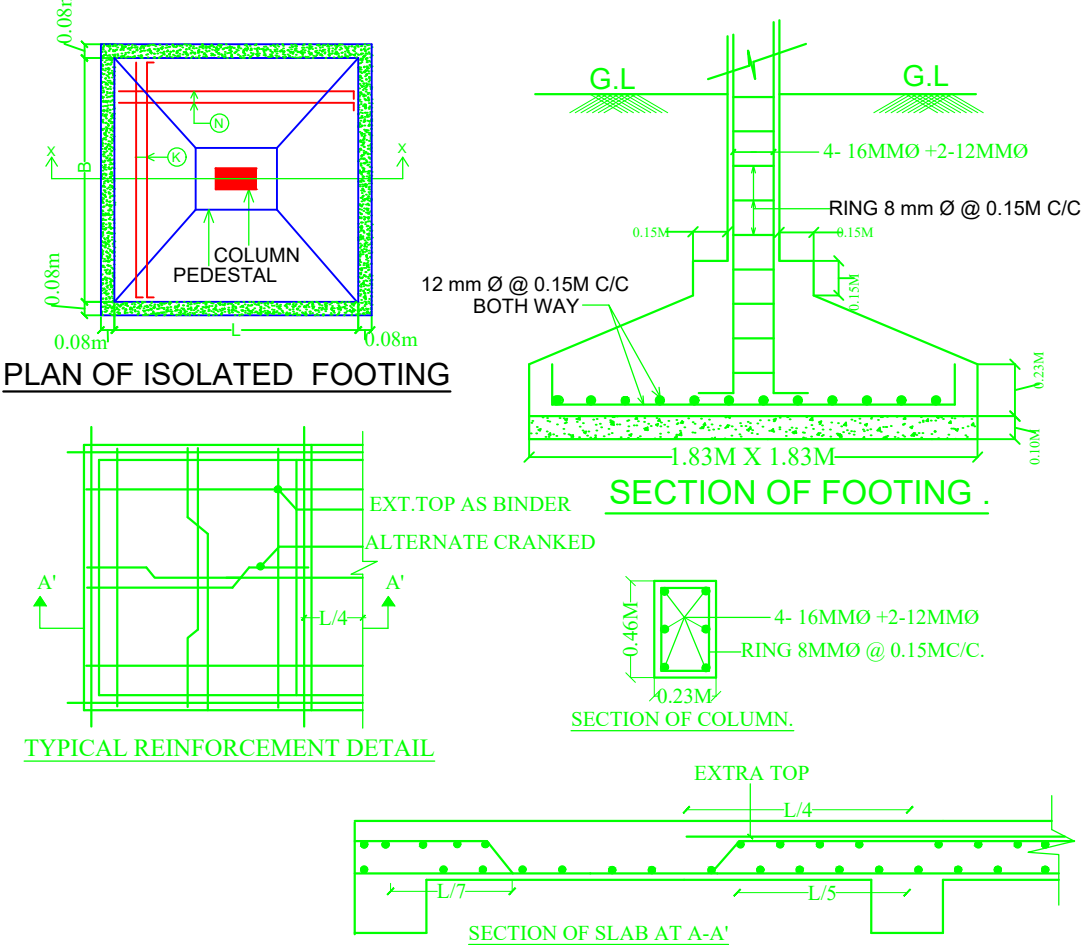
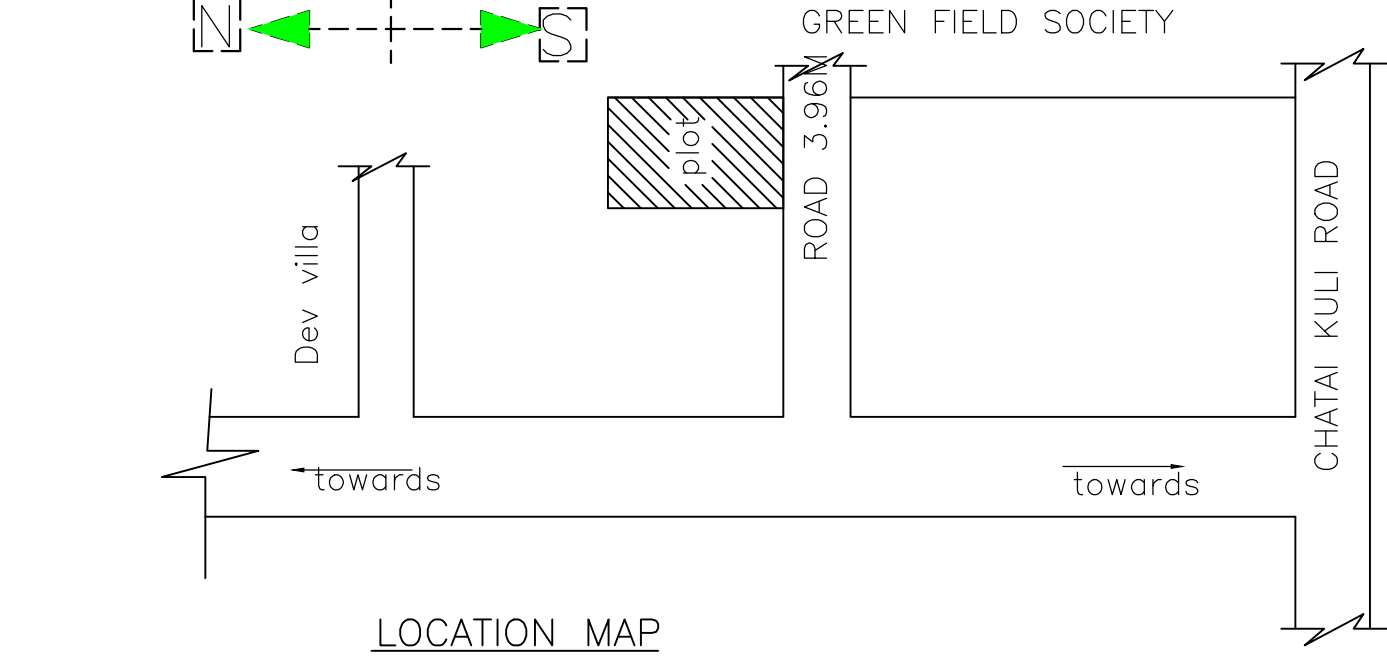
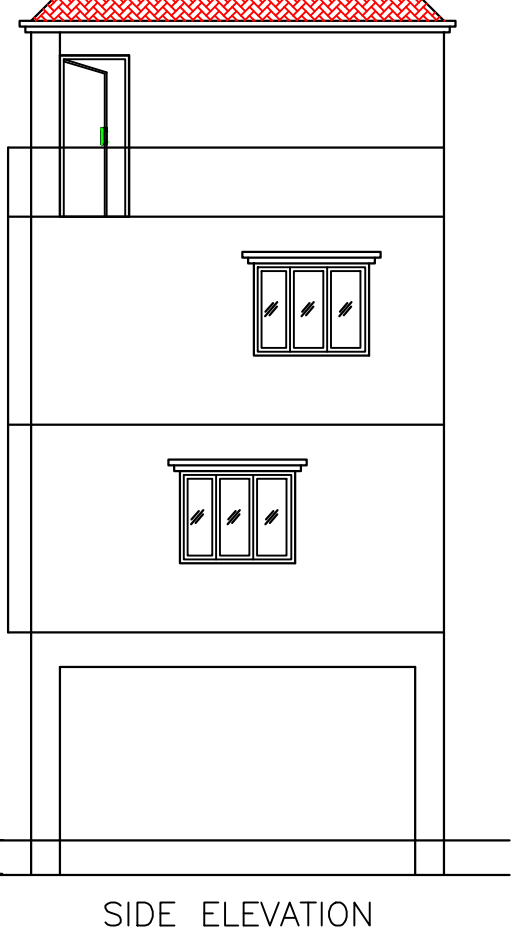
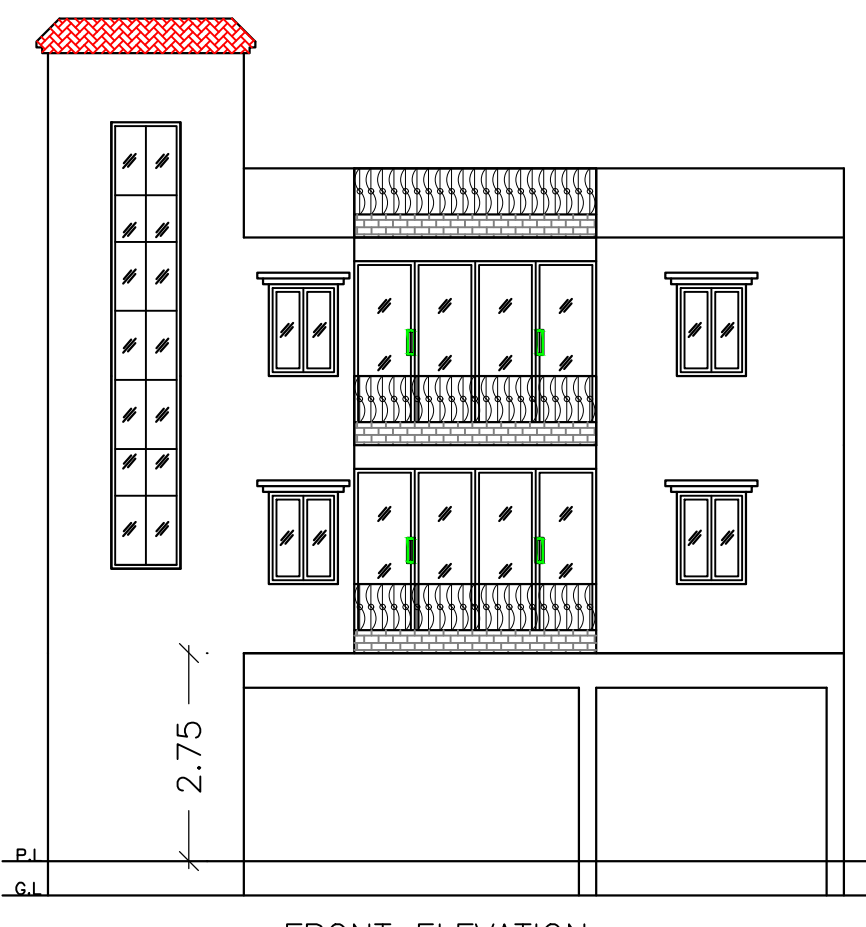
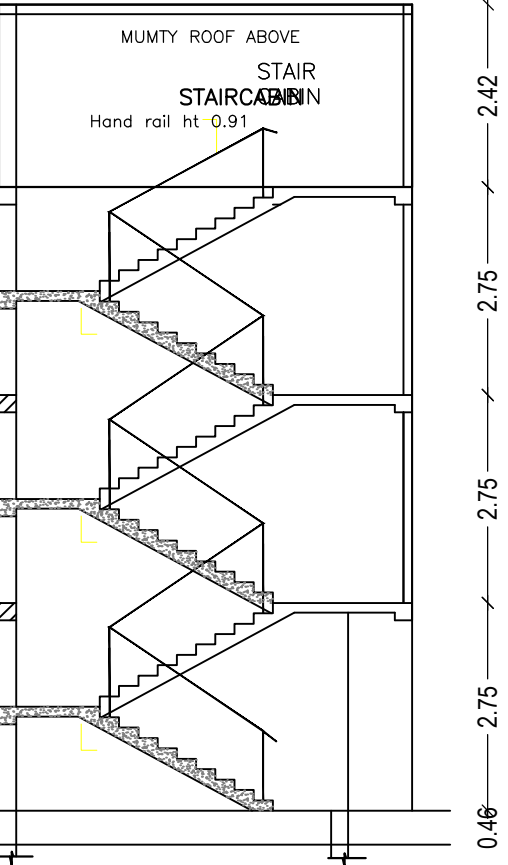
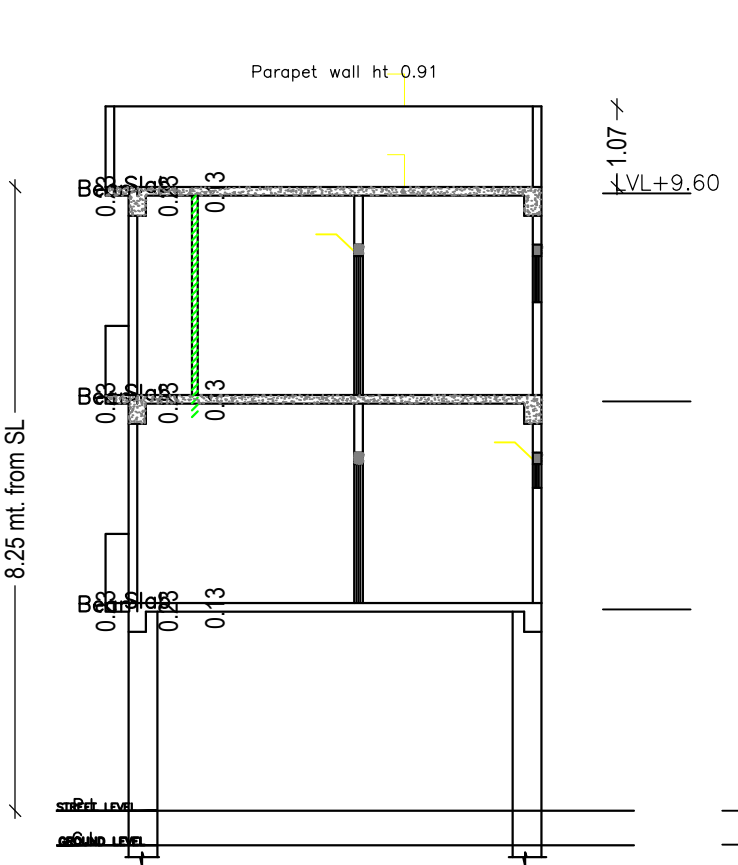
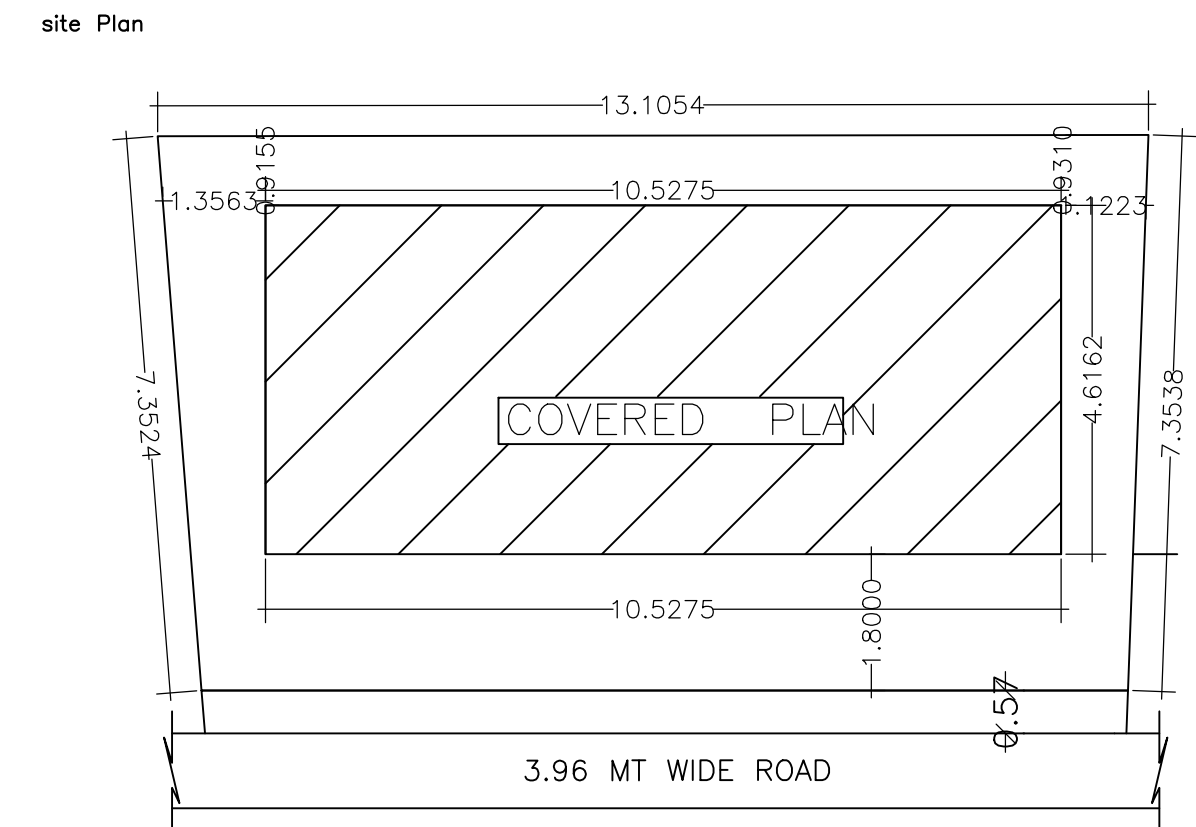
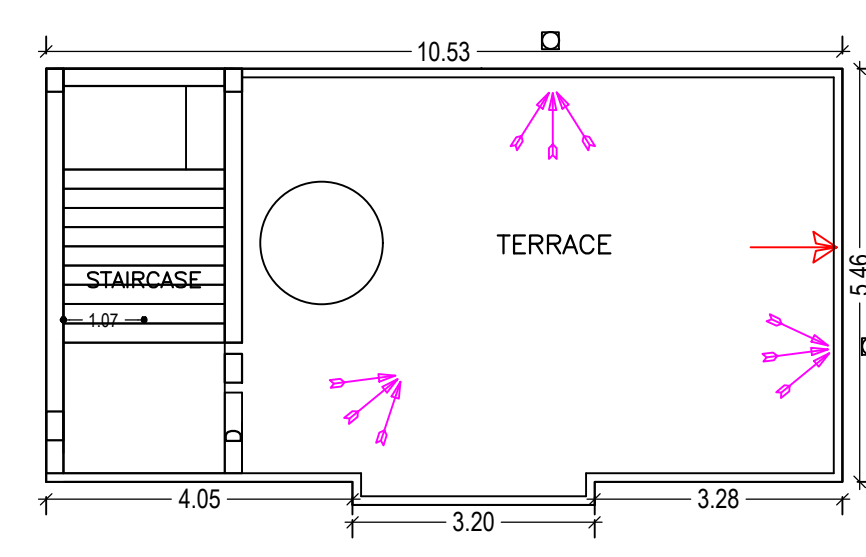
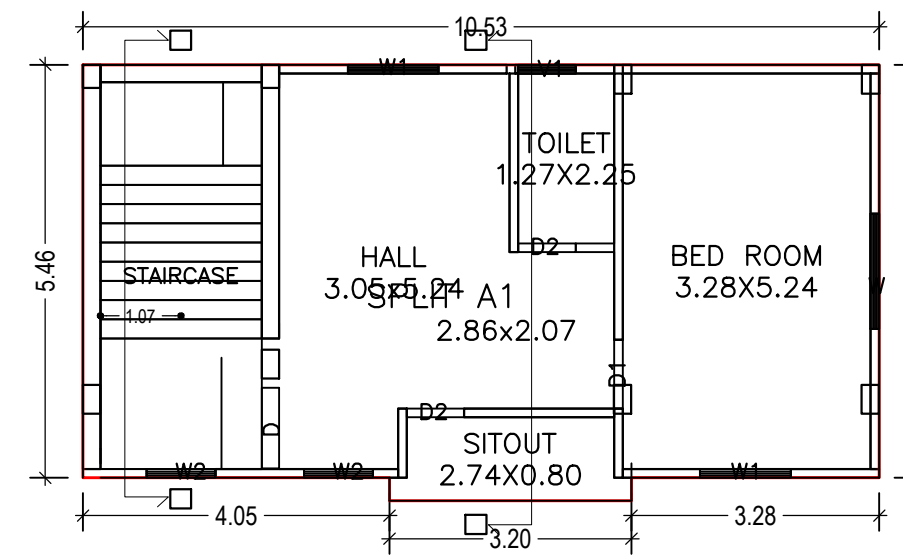
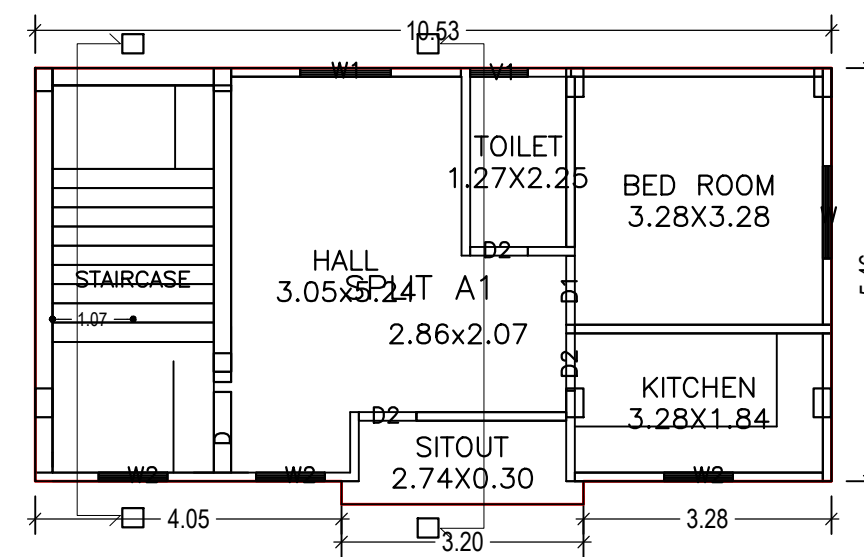
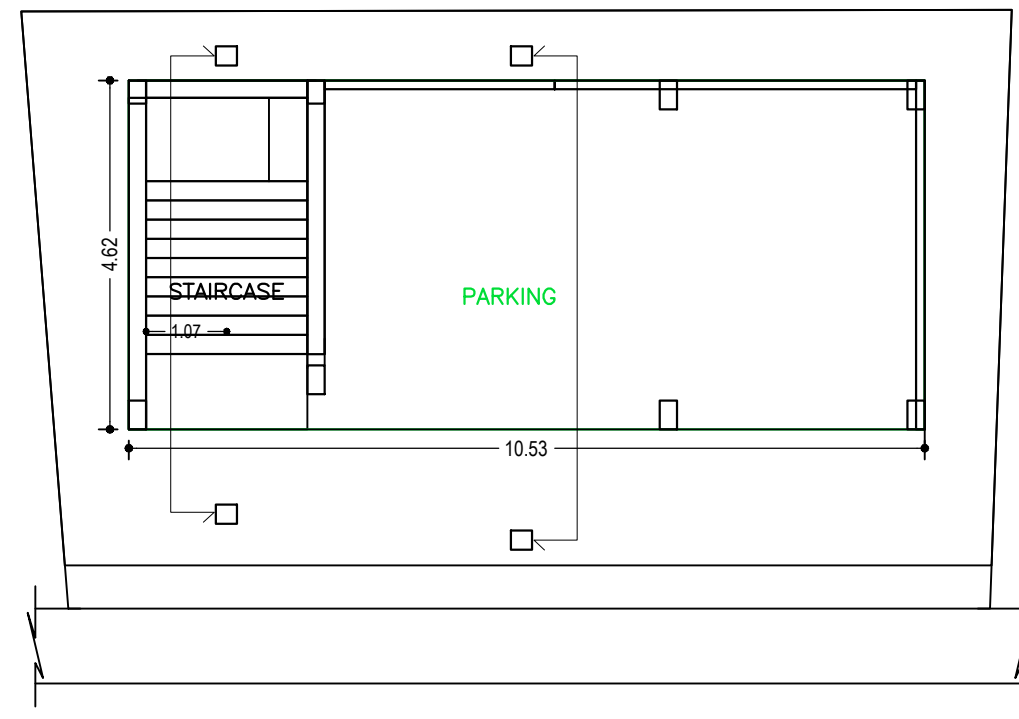
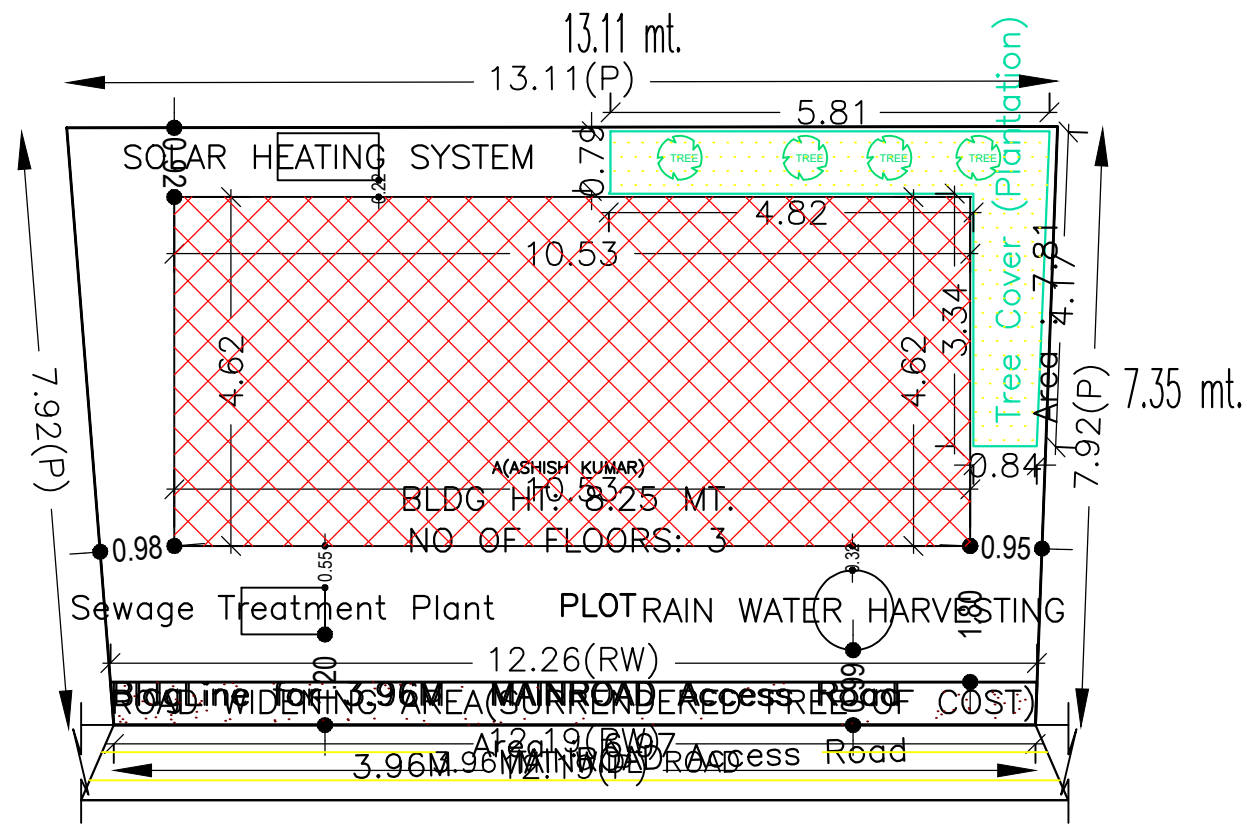

AREA STATEMENT MANGO MUNICIPAL CORPORATION		VERSION NO.: 1.0.46
PROJECT DETAIL:		VERSION DATE: 22/06/2020
Region: JHARKHAND URBAN LOCAL BODIES	Plot Use: Residential	
District: EAST SINGHBHUM	Plot SubUse: Bungalow/ Dwelling / Non Apartment	
Authority: MANGO MUNICIPAL CORPORATION	PlotNearbyReligiousStructure: NA	
Inward No: MNAC/BI/0016/W/10/2020	Plot/SubPlot No: 3298	
Application Type: General Proposal	North: -	
Project Type: Building Permission	South: -	
Nature of Development: New	East: -	
Location of Development Area: Old Area	West: -	
AREA DETAILS:		
AREA OF PLOT (Minimum)	(A)	SQ.MT. 100.04
Deduction for NetPlot Area		
Surrender Free of Cost		6.97
Total		6.97
NET AREA OF PLOT(Gross Plot Area - Deduction from Gross Plot area)	(A-Deductions)	93.07
Deduction for Balance Plot Area(from Gross Plot Area)		
Surrender Free of Cost		6.97
Common Plot		7.81
Total		14.78
BALANCE AREA OF PLOT(Net Plot Area - Recreational/Amenity space)	(A-Deductions)	85.26
PLOT AREA FOR COVERAGE(Net Plot Area)	(A-Deductions)	93.07
Plot Area for FAR (Net Plot Area + RoadWidening Area)	(A-Deductions)	100.04
COVERAGE CHECK		
Permissible Coverage area (70.00 %)		65.15
Proposed Coverage Area (52.22 %)		48.60
Total Prop. Coverage Area (52.22 %)		48.60
Balance coverage area (17.78 %)		16.55
FAR CHECK		
Perm. FAR Area (1.50)		150.06
Total Perm. FAR area		150.06
Residential FAR		117.07
Proposed FAR Area		126.43
Total Proposed FAR Area		126.43
Consumed FAR (Factor)		1.26
Balance FAR Area		23.63
BUILT UP AREA CHECK		
Total Proposed BuiltUp Area		165.65
ARCHITECT (Regd)	MOHAMMAD BELAL NASIR	
ENGINEER (Regd)		
SUPERVISOR (Regd)		
OWNER (Regd)	ASHISH KUMAR	
DEVELOPMENT AUTHORITY		LOCAL BODY

COLOR INDEX	
PLOT BOUNDARY	Black
ABUTTING ROAD	Green
PROPOSED CONSTRUCTION	Red
COMMON PLOT	Yellow
ROAD WIDENING AREA	Blue
EXISTING (To be retained)	Orange
EXISTING (To be demolished)	Grey

Building :A(ASHISH KUMAR)							
Floor Name	Total Built Up Area (Sq.mt.)	Deductions (Area in Sq.mt.)	Proposed FAR		Total FAR Area (Sq.mt.)	Total Consumed Additional FAR Area (Sq.mt.)	Tnmt (No.)
			Area (Sq.mt.)	Resi.			
Ground Floor	48.59	39.23	0.00	9.36	9.36	9.36	00
First Floor	58.53	0.00	58.53	0.00	58.53	58.53	01
Second Floor	58.53	0.00	58.53	0.00	58.53	58.53	00
Terrace Floor	0.00	0.00	0.00	0.00	0.00	0.00	00
Total :	165.65	39.23	117.06	9.36	126.42	126.42	01
Total Number of Same Buildings :	1						
Total :	165.65	39.23	117.06	9.36	126.42	126.42	01

SCHEDULE OF DOOR:				
BUILDING NAME	NAME	LENGTH	HEIGHT	NOS
A(ASHISH KUMAR)	D2	0.76	2.13	05
A(ASHISH KUMAR)	D1	0.91	2.13	02
A(ASHISH KUMAR)	D	1.07	2.10	02

SCHEDULE OF WINDOW/VENTILATION:				
BUILDING NAME	NAME	LENGTH	HEIGHT	NOS
A(ASHISH KUMAR)	V1	0.76	1.22	02
A(ASHISH KUMAR)	W2	0.91	1.22	05
A(ASHISH KUMAR)	W1	1.20	1.22	03
A(ASHISH KUMAR)	W	1.22	1.22	01
A(ASHISH KUMAR)	W	1.52	1.22	01

FAR & Tenement Details (Table 4c-1)							
Building	No. of Same Bldg	Total Built Up Area (Sq.mt.)	Proposed FAR Area (Sq.mt.)		Total FAR Area (Sq.mt.)	Tnmt (No.)	
			Parking	Resi.			
1	1	165.65	39.23	117.06	126.42	126.42	01
Grand Total :	1	165.65	39.23	117.06	126.42	126.42	01

UnitBUA Table for Building :A(ASHISH KUMAR)						
FLOOR	Name	UnitBUA Type	UnitBUA Area	Carpet Area	No. of Rooms	No. of Tenement
FIRST FLOOR PLAN	SPLIT A1	FLAT	117.07	106.11	5	1
SECOND FLOOR PLAN	SPLIT A1	FLAT	0.00	0.00	4	0
Total:	-	-	117.07	106.11	9	1

LTP NAME AND SIGNATURE	STRUCTURAL ENG'S NAME AND SIGNATURE	BUILDER NAME AND SIGNATURE	DIGITAL SIGNATURE
MOHAMMAD BELAL NASIR MNAC/ENG/0007/2016			