

Proposal Basic Information	
Proposal File No.	MNAC/EP/0045/W08/2020
Owner Name	Roshan Ara
Khata No	487
Plot No	803
Village Name	Pardih
Use	Residential
SubUse	Bungalow/ Dwelling / Non Apartment

Required Parking (Table 7a)

Building Name	Type	SubUse	Area (Sq.mt.)	Units		Car		Visitors Car		
				Reqd.	Prop.	Reqd./Unit	Reqd.	Prop.	Reqd./Unit	Reqd.
A (RAUSHAN ARA)	Residential	Bungalow/ Dwelling / Non Apartment	>0	1	2.00	1.00	2	-	-	-
			>0	1	2.00	-	-	1	1	-
Total :			-	-	-	-	2	2	-	1 1

Parking Check (Table 7b)

Vehicle Type	Reqd.		Prop.	
	No.	Area	No.	Area
Car	-	-	2	25.00
Total Car	2	25.00	2	25.00
Visitor's Car Parking	-	-	1	12.50
Total Visitor Parking	1	12.50	1	12.50
Other Parking	-	-	-	56.31
Total		37.50		93.81

Buildingwise Floor FAR Details

Floor Name	Building Name		Total	
	Proposed Built Up Area (Sq.mt.)	Proposed FAR Area (Sq.mt.)	Total Proposed Built Up Area (Sq.mt.)	Total FAR Area (Sq.mt.)
Basement Floor	100.79	6.97	100.79	6.97
Ground Floor	100.79	100.79	100.79	100.79
First Floor	100.79	100.79	100.79	100.79
Second Floor	100.79	100.79	100.79	100.79
Terrace Floor	0.00	0.00	0.00	0.00
Total :	403.16	309.34	403.16	309.34

Building USE/SUBUSE Details

Building Name	Building Use	Building SubUse	Building Structure
A (RAUSHAN ARA)	Residential	Bungalow/ Dwelling / Non Apartment	Non-Highrise

COLOR INDEX	
PLOT BOUNDARY	Black
ABUTTING ROAD	Green
PROPOSED CONSTRUCTION	Red
COMMON PLOT	Yellow
ROAD WIDENING AREA	Blue
EXISTING (To be retained)	Orange
EXISTING (To be demolished)	Light Blue

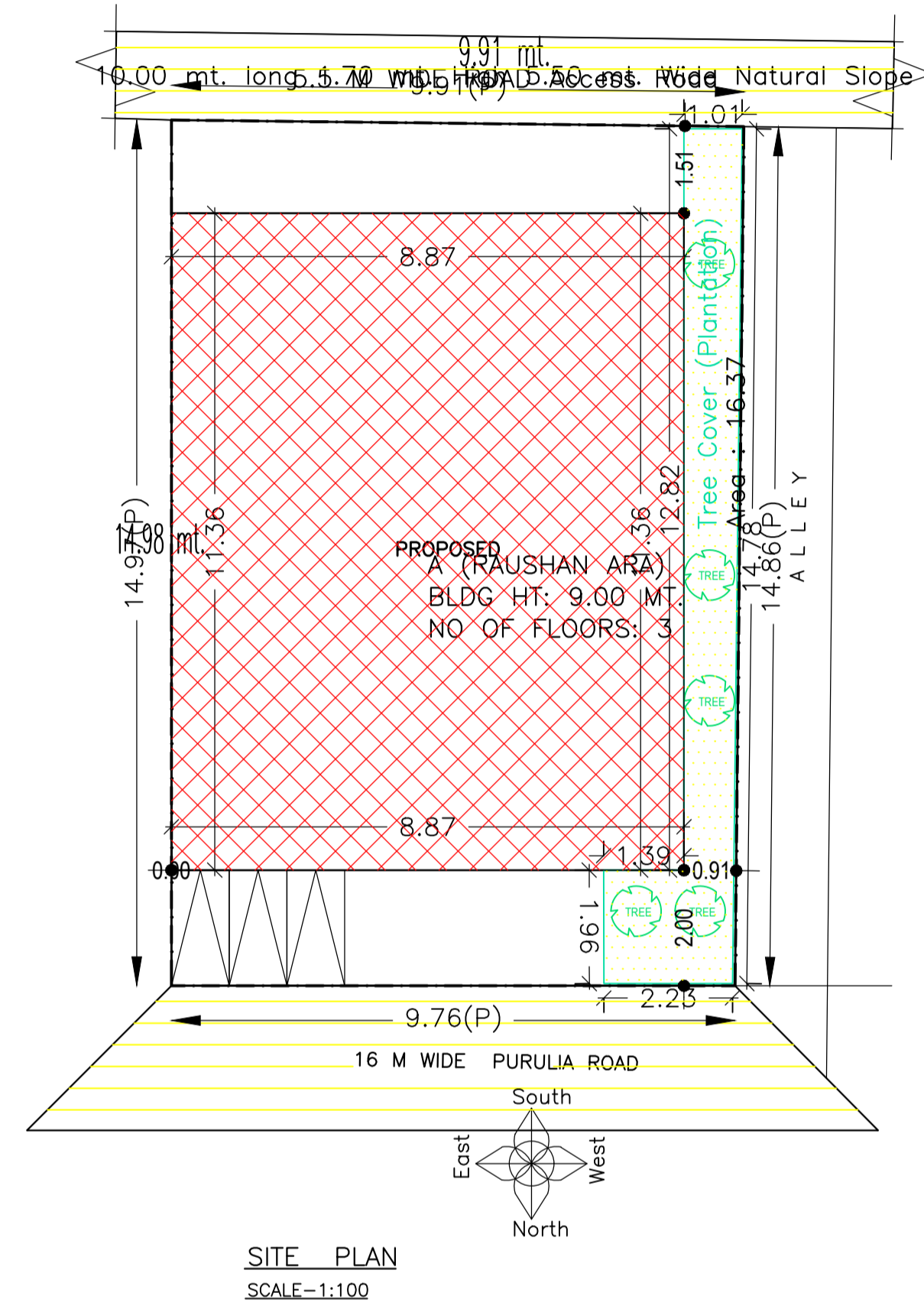

SITE PLAN  
SCALE=1:100

AREA STATEMENT MANGO MUNICIPAL CORPORATION		VERSION NO. : 1.0.53
PROJECT DETAIL :		VERSION DATE: 16/10/2020
Region: JHARKHAND URBAN LOCAL BODIES	Plot Use: Residential	
District: EAST SINGHBHUM	Plot SubUse: Bungalow/ Dwelling / Non Apartment	
Authority: MANGO MUNICIPAL CORPORATION	Plot/Nearby/Religious/Structure: NA	
Inward No: MNAC/EP/0045/W08/2020	Plot/SubPlot No: 803	
Application Type: General Proposal	North: Road Width - 16 m	
Project Type: Building Permission	South: Survey No. - Road	
Nature of Development: New	East: Survey No. - OTHER PLOT	
Location of Development Area: Old Area	West: Survey No. - OTHER PLOT	
AREA DETAILS:		SQ.MT.
AREA OF PLOT (Minimum)	(A)	146.67
NET AREA OF PLOT (Gross Plot Area - Deduction from Gross Plot area)	(A-Deductions)	146.67
Deduction for Balance Plot Area (from Gross Plot Area)		
Common Plot		16.37
Total		16.37
BALANCE AREA OF PLOT (Net Plot Area - Recreational/Amenity space)	(A-Deductions)	130.30
PLOT AREA FOR COVERAGE (Net Plot Area)	(A-Deductions)	146.67
Plot Area for FAR (Net Plot Area + Road Widening Area)	(A-Deductions)	146.67
COVERAGE CHECK		
Permissible Coverage area ( 70.00 % )		102.67
Proposed Coverage Area ( 68.72 % )		100.79
Total Prop. Coverage Area ( 68.72 % )		100.79
Balance coverage area ( 1.28 % )		1.88
FAR CHECK		
Perm. FAR Area ( 2.50 )		366.67
Total Perm. FAR area		366.67
Residential FAR		302.36
Proposed FAR Area		309.33
Total Proposed FAR Area		309.33
Consumed FAR (Factor)		2.11
Balance FAR Area		57.34
BUILT UP AREA CHECK		
Total Proposed BuiltUp Area		403.16
ARCHITECT (Regd)		L K Suman
ENGINEER (Regd)		
SUPERVISOR (Regd)		
OWNER (Regd)		Roshan Ara
DEVELOPMENT AUTHORITY		LOCAL BODY

FAR & Tenement Details (Table 4c-1)

Building	No. of Same Bldg	Total Built Up Area (Sq.mt.)	Deductions (Area in Sq.mt.)	Proposed FAR Area (Sq.mt.)		Add Area In FAR (Sq.mt.)	Total FAR Area (Sq.mt.)	Total Consumed Additional FAR Area (Sq.mt.)	Trmt (No.)
				Parking	Resi.				
A (RAUSHAN ARA)	1	403.16	93.81	302.37	6.97	309.34	309.34	02	
Grand Total :	1	403.16	93.81	302.37	6.97	309.34	309.34	02	

LTP NAME AND SIGNATURE	STRUCTURAL ENG'S NAME AND SIGNATURE	BUILDER NAME AND SIGNATURE	DIGITAL SIGNATURE
L K Suman MNAC/ENG/0008/2016			

Proposal Basic Information	
Proposal File No.	MNAC/ENG/0045/W08/2020
Owner Name	Roshan ARA
Khata No	487
Plot No	803
Village Name	Pardih
Use	Residential
SubUse	Bungalow/ Dwelling / Non Apartment

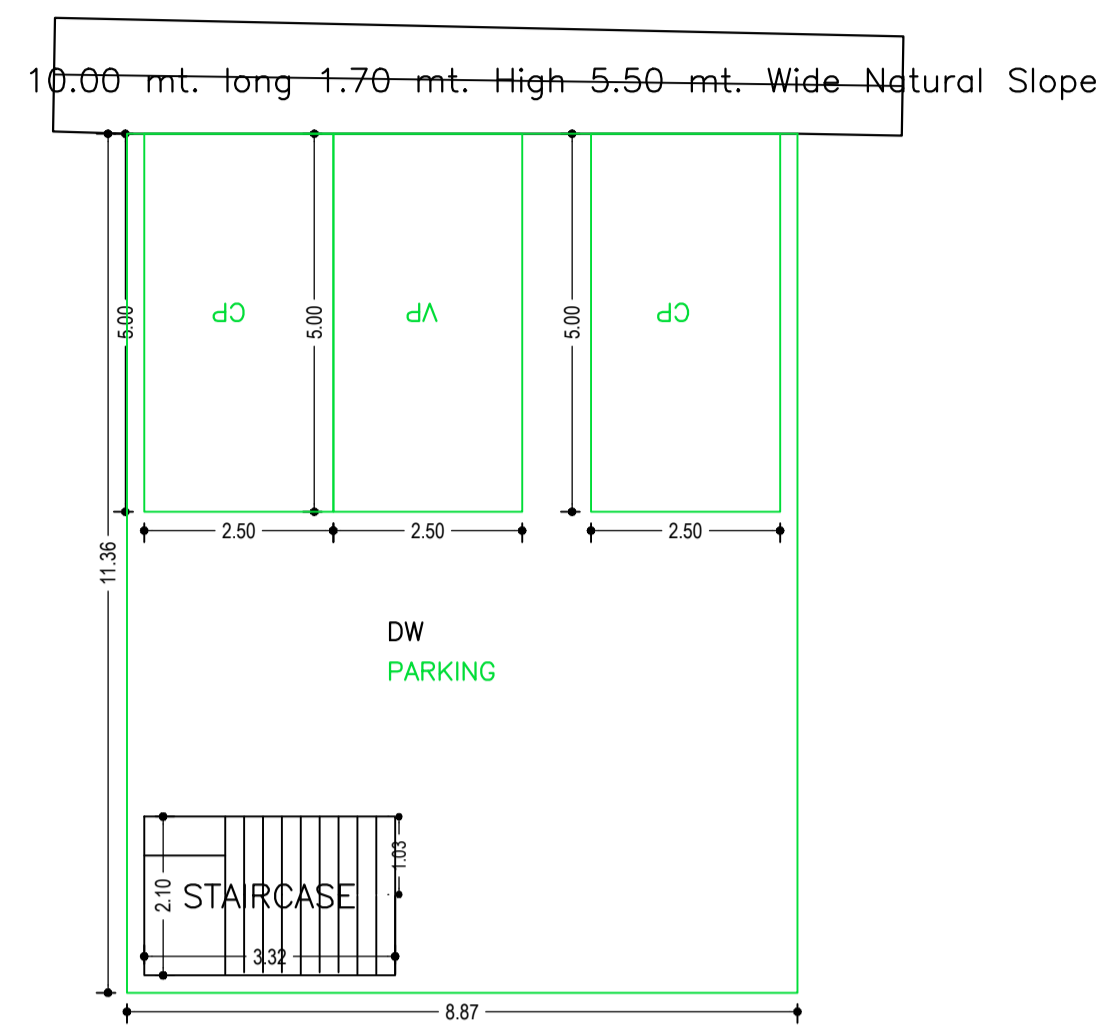

BASEMENT FLOOR PLAN  
(SCALE 1:100)

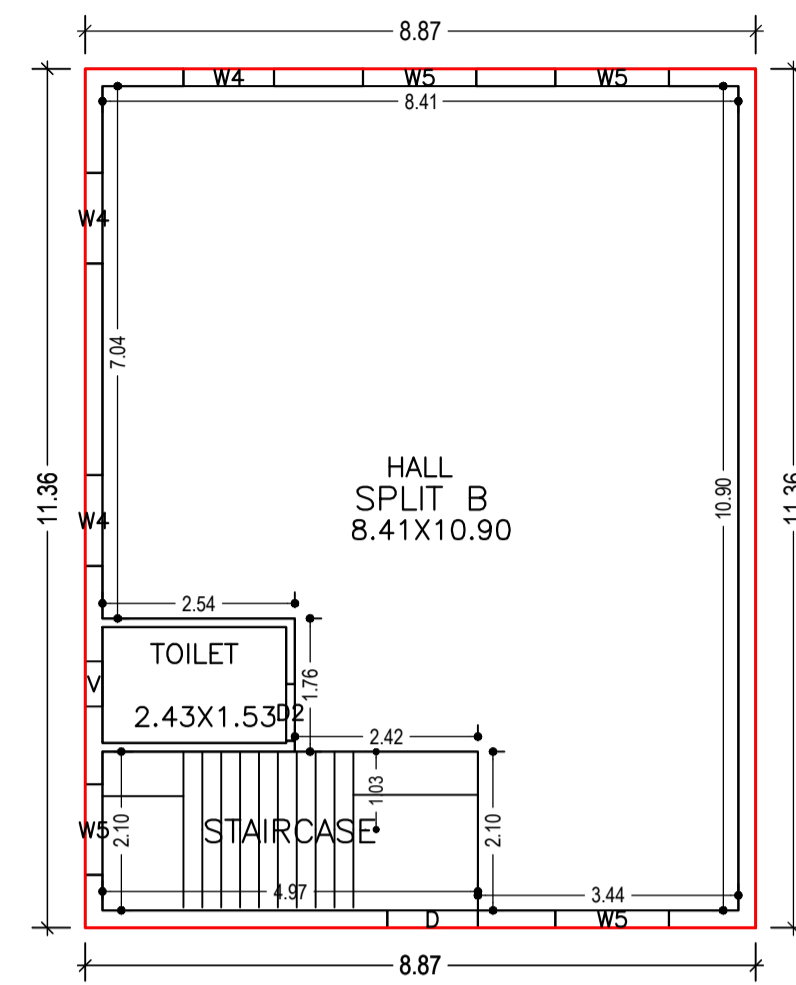

GROUND FLOOR PLAN  
(Proposed)  
(SCALE 1:100)

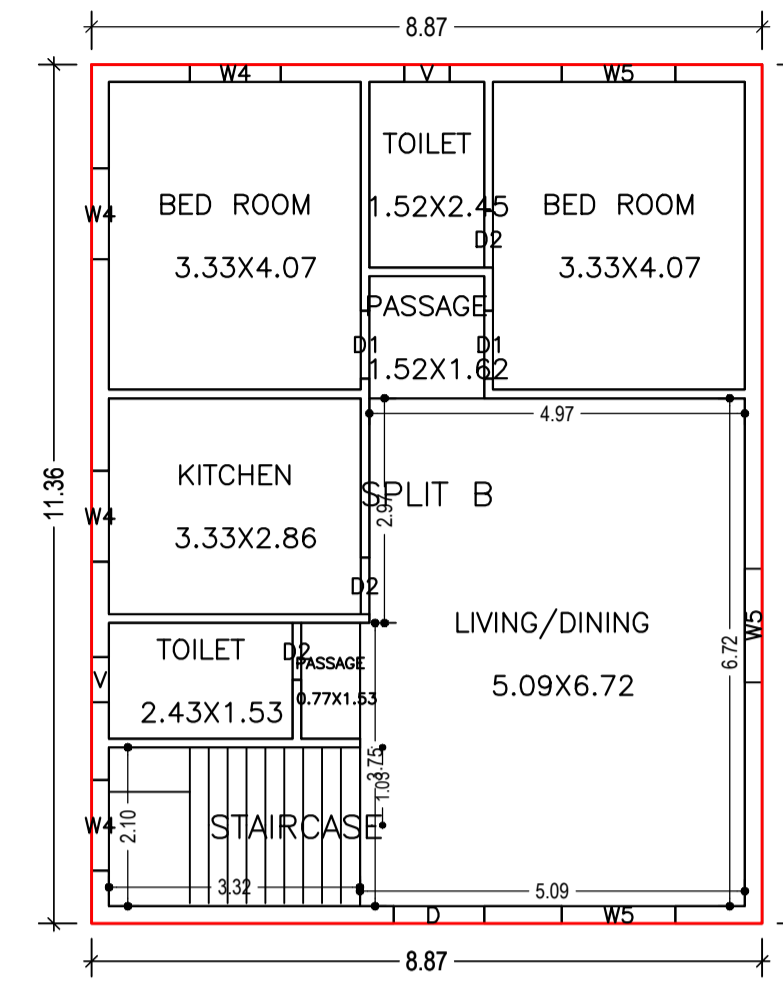

FIRST FLOOR PLAN  
(Proposed)  
(SCALE 1:100)

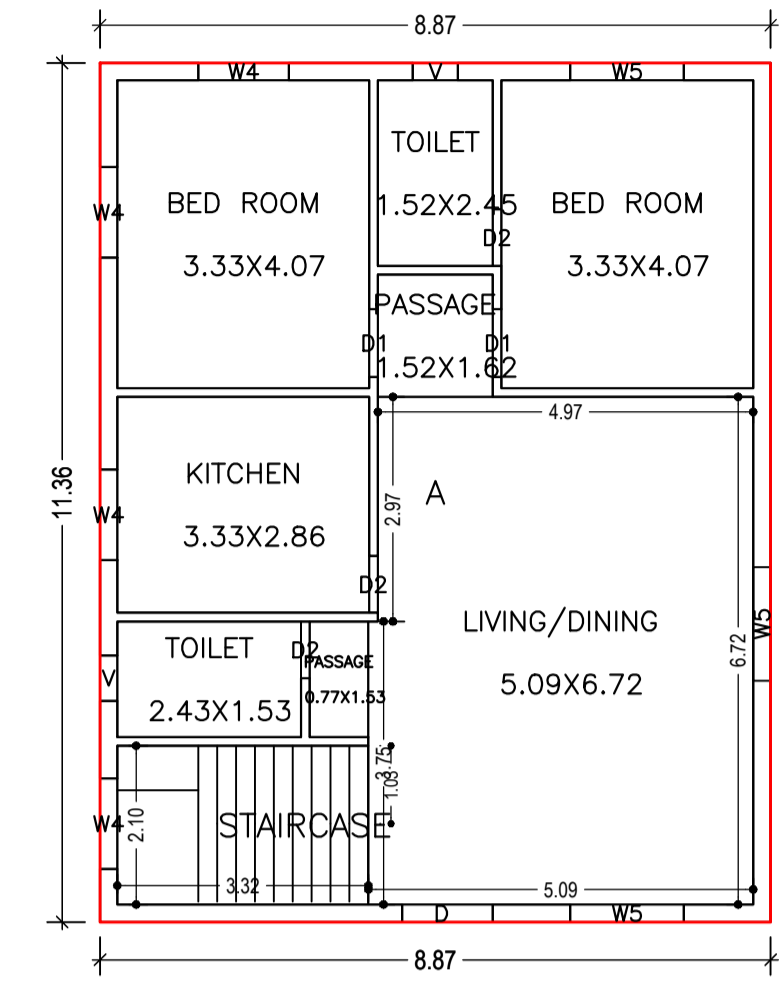

SECOND FLOOR PLAN  
(Proposed)  
(SCALE 1:100)

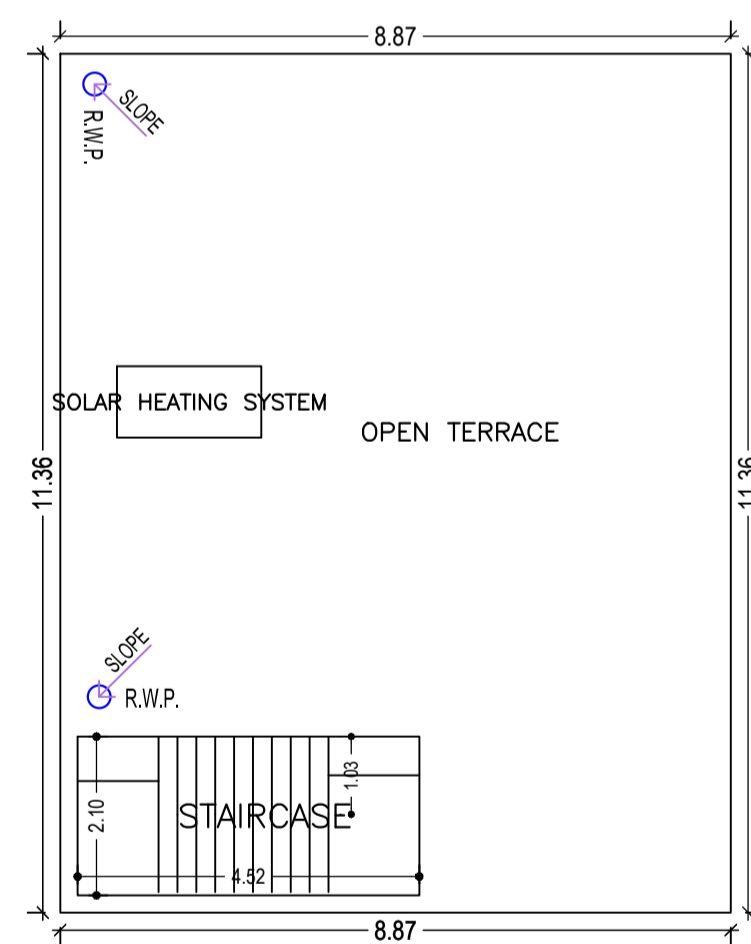

TERRACE FLOOR PLAN  
(SCALE 1:100)

Building :A (RAUSHAN ARA)

Floor Name	Total Built Up Area (Sq.mt.)	Deductions (Area in Sq.mt.)		Proposed FAR Area (Sq.mt.)	Add Area In FAR (Sq.mt.)	Total FAR Area (Sq.mt.)	Total Consumed Additional FAR Area (Sq.mt.)	Trmt (No.)
		Parking	Resi.					
Basement Floor	100.79	93.81	0.00	6.97	6.97	6.97	00	
Ground Floor	100.79	0.00	100.79	0.00	100.79	100.79	01	
First Floor	100.79	0.00	100.79	0.00	100.79	100.79	00	
Second Floor	100.79	0.00	100.79	0.00	100.79	100.79	01	
Terrace Floor	0.00	0.00	0.00	0.00	0.00	0.00	00	
Total :	403.16	93.81	302.37	6.97	309.34	309.34	02	
Total Number of Same Buildings :	1							
Total :	403.16	93.81	302.37	6.97	309.34	309.34	02	

SCHEDULE OF DOOR:

BUILDING NAME	NAME	LENGTH	HEIGHT	NOS
A (RAUSHAN ARA)	D2	0.75	2.10	07
A (RAUSHAN ARA)	D1	0.90	2.10	04
A (RAUSHAN ARA)	D	1.20	2.10	02

SCHEDULE OF WINDOW/VENTILATION:

BUILDING NAME	NAME	LENGTH	HEIGHT	NOS
A (RAUSHAN ARA)	V	0.60	0.60	05
A (RAUSHAN ARA)	W4	1.20	1.20	11
A (RAUSHAN ARA)	W5	1.20	1.20	01
A (RAUSHAN ARA)	W5	1.50	1.20	09

LTP NAME AND SIGNATURE	STRUCTURAL ENG'S NAME AND SIGNATURE	BUILDER NAME AND SIGNATURE	DIGITAL SIGNATURE
L K Suman MNAC/ENG/0008/2016			

Proposal Basic Information	
Proposal File No.	MNAC/ENG/0045/W08/2020
Owner Name	Roshan ARA
Khata No	487
Plot No	803
Village Name	Pardih
Use	Residential
SubUse	Bungalow/ Dwelling / Non Apartment

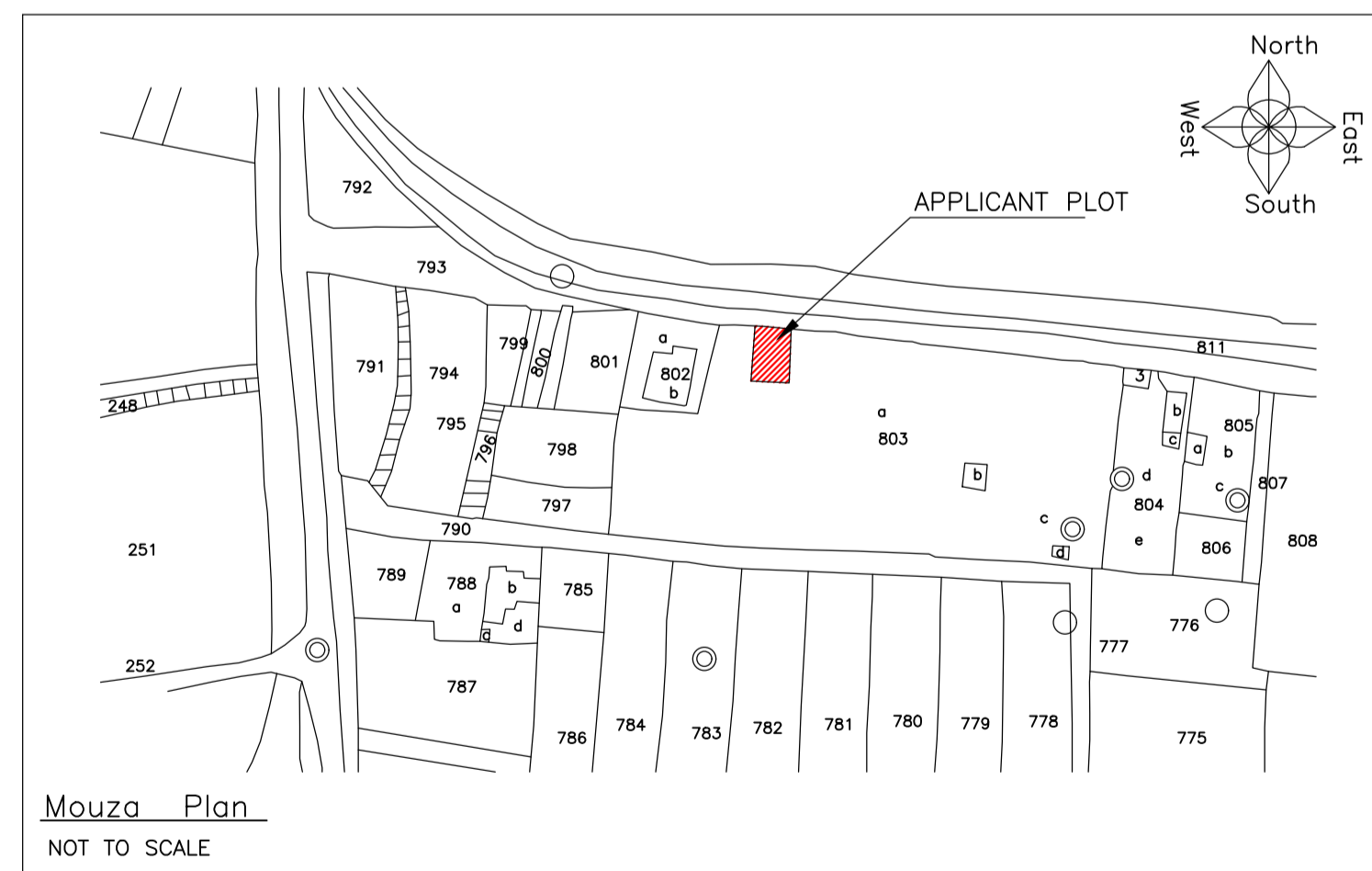
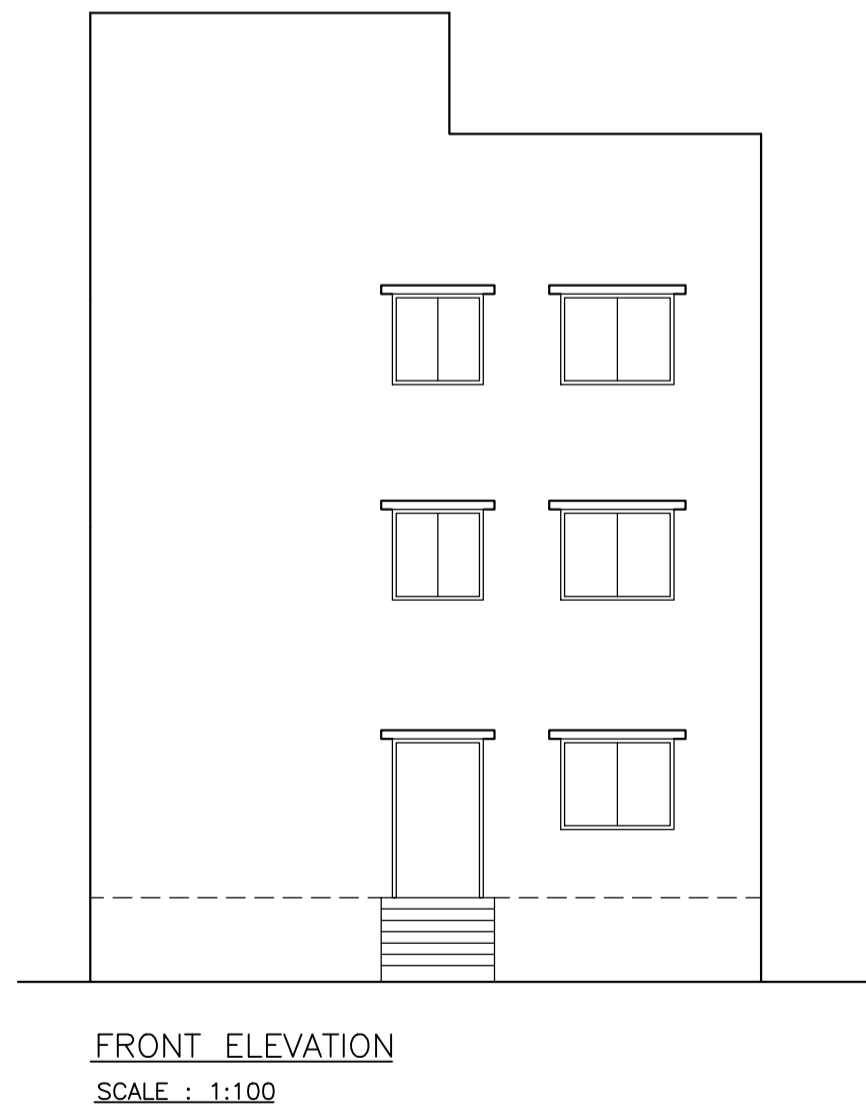
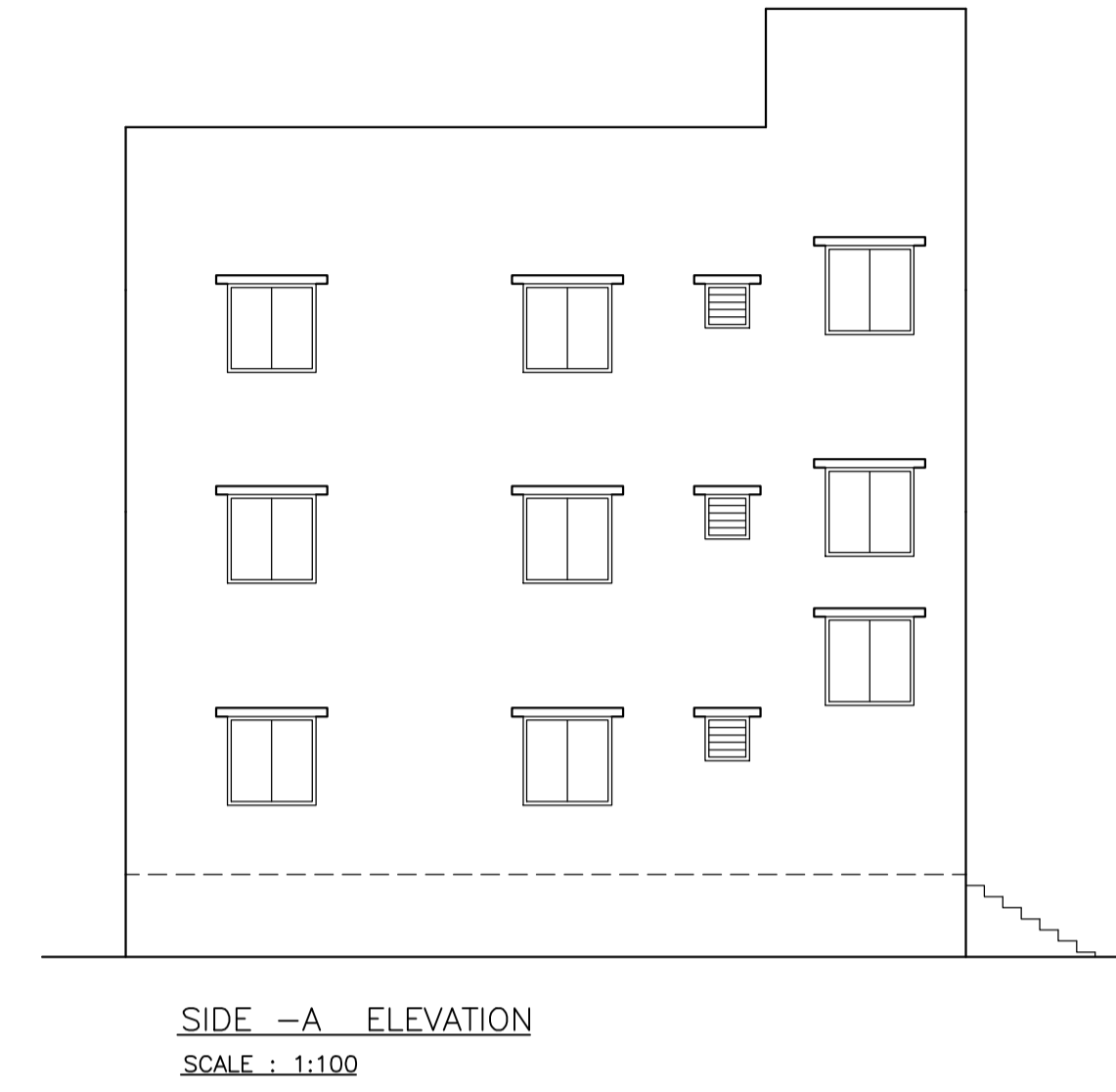
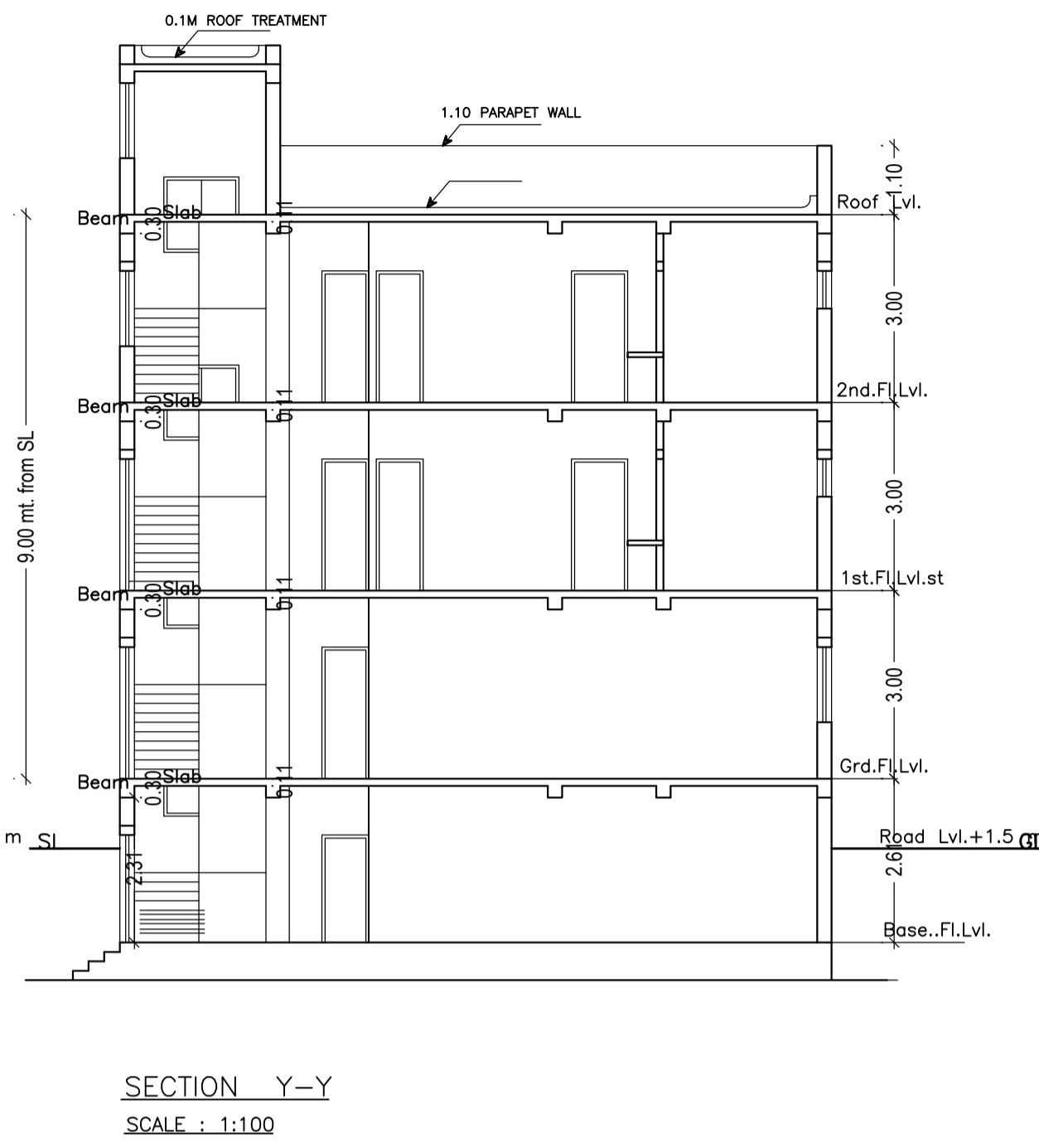
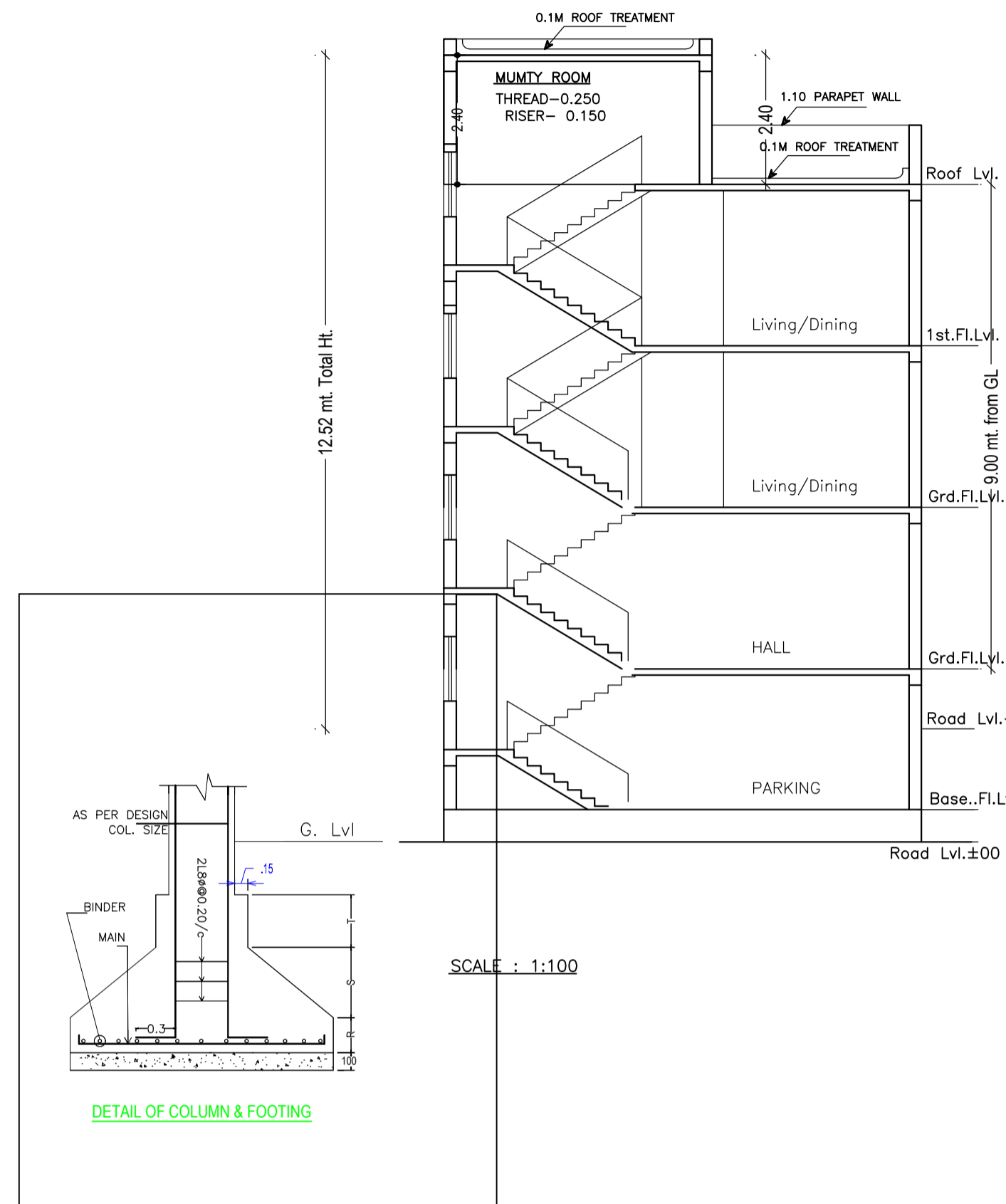
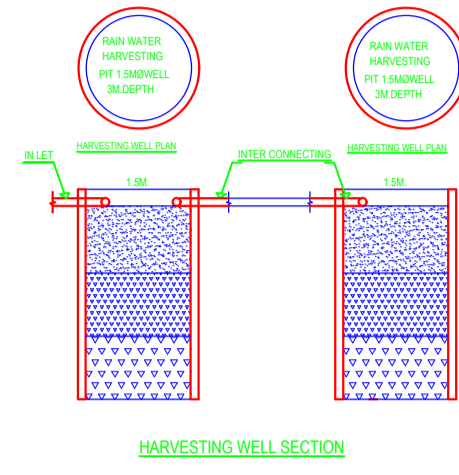

UnitBUA Table for Building :A (RAUSHAN ARA)

FLOOR	Name	UnitBUA Type	UnitBUA Area	Carpet Area	No. of Rooms	No. of Tenement
GROUND FLOOR PLAN	SPLIT B	FLAT	201.57	184.75	2	1
FIRST FLOOR PLAN	SPLIT B	FLAT	0.00	0.00	8	0
SECOND FLOOR PLAN	A	FLAT	100.79	91.32	8	1
Total:	-	-	302.36	276.07	18	2

LTP NAME AND SIGNATURE	STRUCTURAL ENG'S NAME AND SIGNATURE	BUILDER NAME AND SIGNATURE	DIGITAL SIGNATURE
L K Suman MNAC/ENG/0008/2016			