

Project Title : FARHAT RAUSHAN ARA

S.No	TYPE	LENGTH	HEIGHT	SELL LEVEL	LAYTEL LEVEL	DESCRIPTION
1	D	1.05m	2.10m	0.0m	2.1m	FULLY GLASS DOOR
2	D1	0.90m	2.10m	0.0m	2.1m	FULLY GLASS DOOR
3	DE	0.75m	2.10m	0.0m	2.1m	FULLY GLASS DOOR
4	WS	1.50m	1.20m	0.90m	2.1m	FULLY GLASS STEEL WINDOW
5	WS	1.20m	1.20m	0.90m	2.1m	FULLY GLASS STEEL WINDOW
6	WS	0.90m	1.20m	0.90m	2.1m	FULLY GLASS STEEL WINDOW
7	V	0.60m	0.60m	2.1m	2.7m	FULLY GLASS VENTILATOR

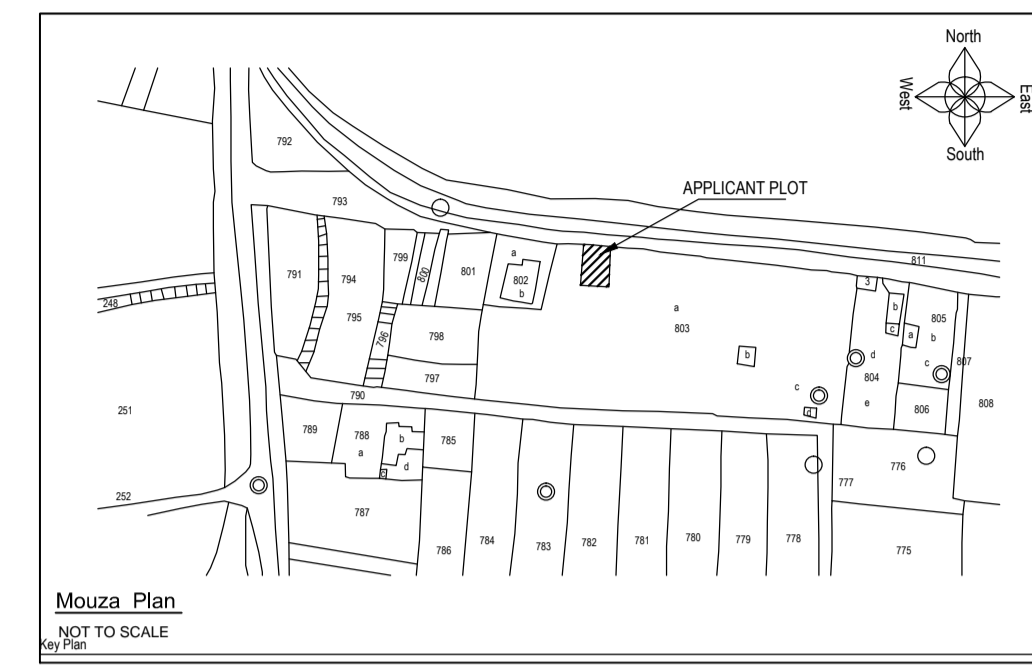
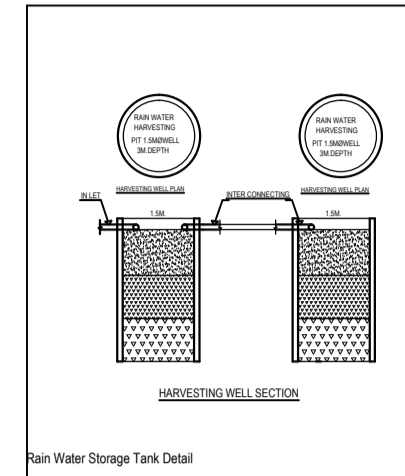
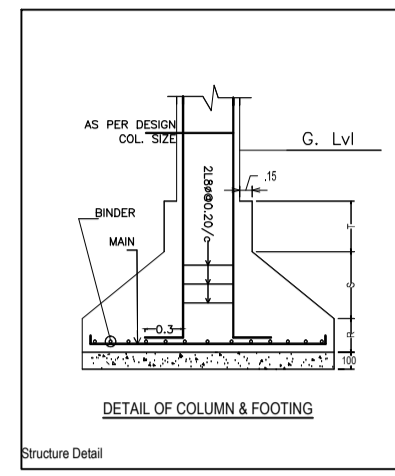

PROJECT DETAIL:		VERSION NO. 1.0.23
Item No.:		DATE: 01/01/2019
Region:	HARHARD URBAN LOCAL BODIES	Plot Use: Residential
Street:	EAST SINGURHUM	Plot Sub-Use: Bungalow Dwelling / Non Apartment
Application Type:	General Proposal	Land Use Zone: NA
Project Type:	Building Permission	Abutting Road Width: -
Year of Development:	New	Revenue Survey No/Survey No.:
Location:	Old Area	Thana No.:
Sub Location:	NA	Holding No.:
Village/Moza Name:	-	Khata No.:
Ward No.:	-	North:
Road/Street:	-	South:
		East:
		West:

AREA DETAILS:		SCMT
AREA OF PLOT (Minimum)	(A)	146.99
Net Plot Area (Gross Plot Area)	(A-Deductions)	146.99
Deduction from Gross Plot Area		
Deduction for Balance Net Area (from Gross Plot Area)		
COV Area		16.37
Balance Plot Area (Net Plot Area - Recreational/Amenity space)	(A-Deductions)	130.62
Plot Area for Coverage (Net Plot Area)	(A-Deductions)	146.99
Plot Area for FSI (Net Plot Area - Recreational/Amenity Area)	(A-Deductions)	146.99

COVERAGE CHECK	
Proposed Coverage Area (88.37%)	100.79
Total Coverage Area (88.37%)	100.79
FAR CHECK	
Proposed Area of FAR	309.34
Total Area of FAR	309.34
BULKY UP AREA CHECK	
ARCHITECT/ SUPERVISOR (Name)	OWNER

COLOR INDEX	
PLOT BOUNDARY	---
ABUTTING ROAD	---
PROPOSED WORK (COVERAGE AREA)	---
EXISTING (To be retained)	---
EXISTING (To be demolished)	---

PARKING CALCULATION:	
Other Parking	Prop No. 1, Prop Area 93.81
Total Area	93.81

MARGIN DETAIL:					
Building / Wing Name	Road Name	Front Margin	Rear Margin	Side1 Margin	Side2 Margin
A1 FARHAT RAUSHAN ARA	PURULLA ROAD	2.00	1.52	0.00	0.91

BASEMENT MARGIN DETAIL:					
Building / Wing Name	Road Name	Front Margin	Rear Margin	Side1 Margin	Side2 Margin
A1 FARHAT RAUSHAN ARA	PURULLA ROAD	2.00	1.52	0.00	0.91

FAR & Tenement Details (Table 4c-1)							
Building	No. of Same Bldg	Total Built Up Area (Sq.mt.)	Total FAR Area (Sq.mt.)	Proposed FAR Area (Sq.mt.)	Add Area in FAR (Sq.mt.)	Total FAR Area (Sq.mt.)	Tenent (No.)
A1 FARHAT RAUSHAN ARA	1	403.16	93.81	302.37	6.97	309.34	02
Grand Total:	1	403.16	93.81	302.37	6.97	309.34	02

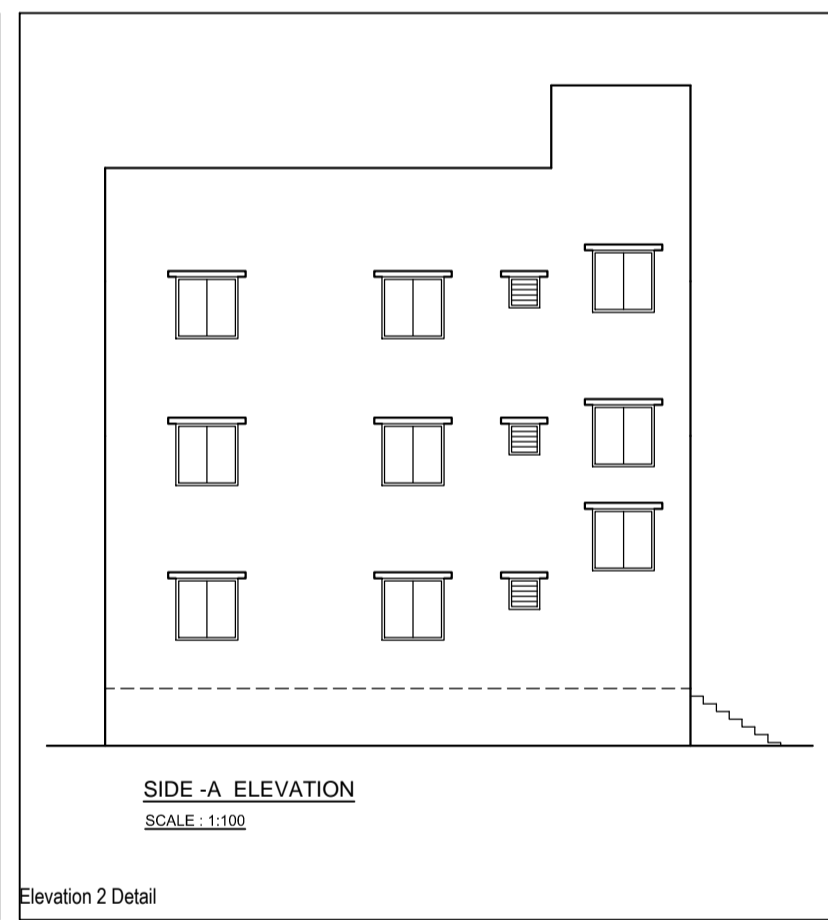
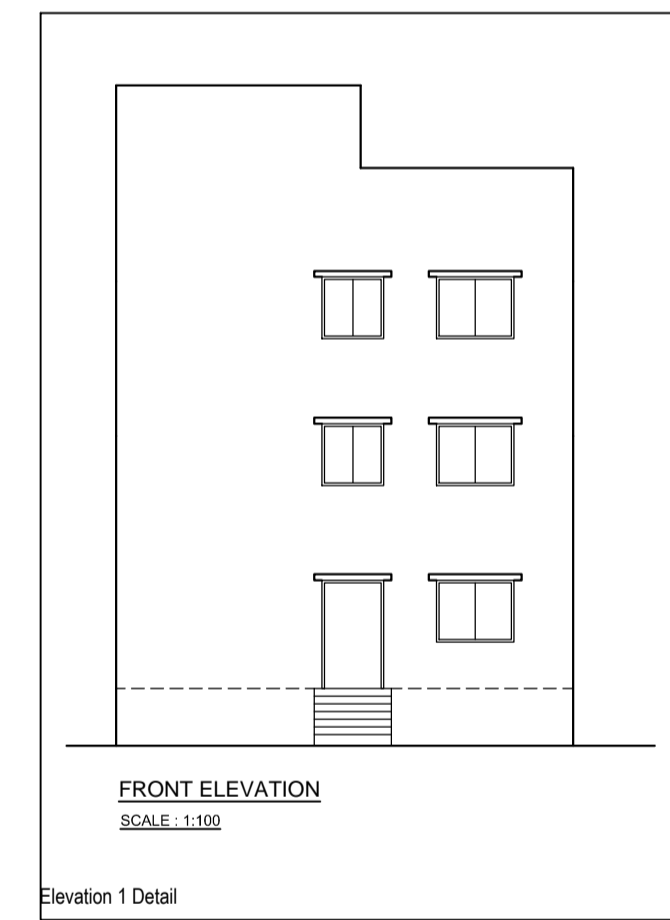
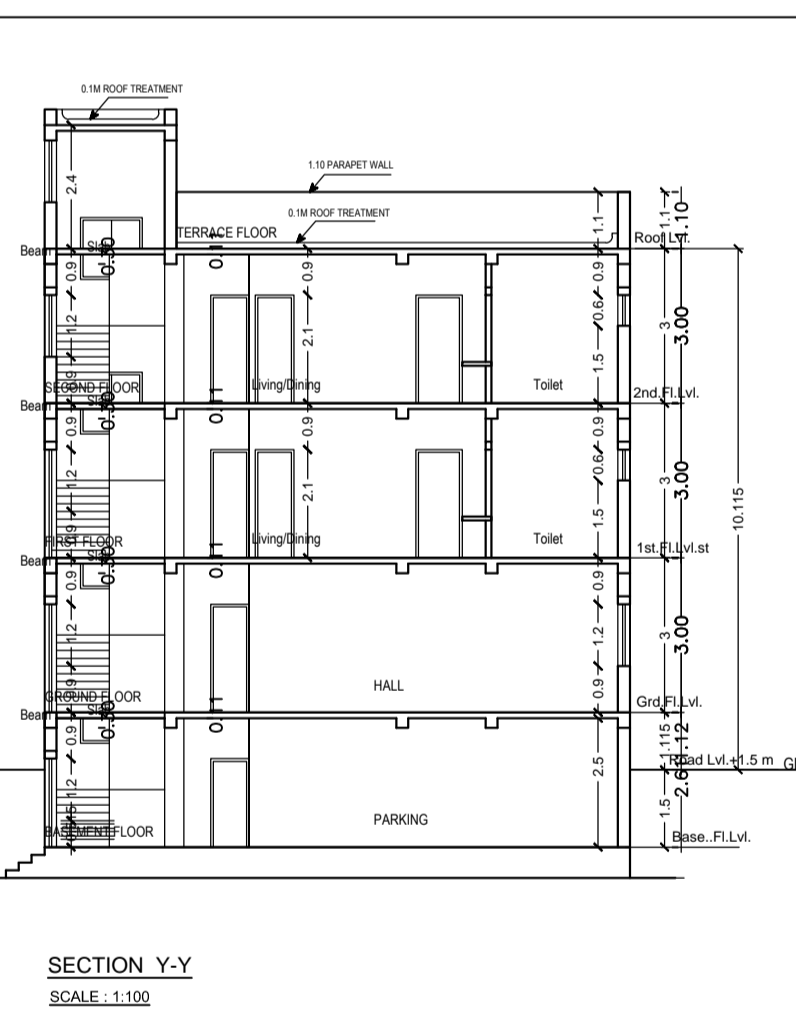
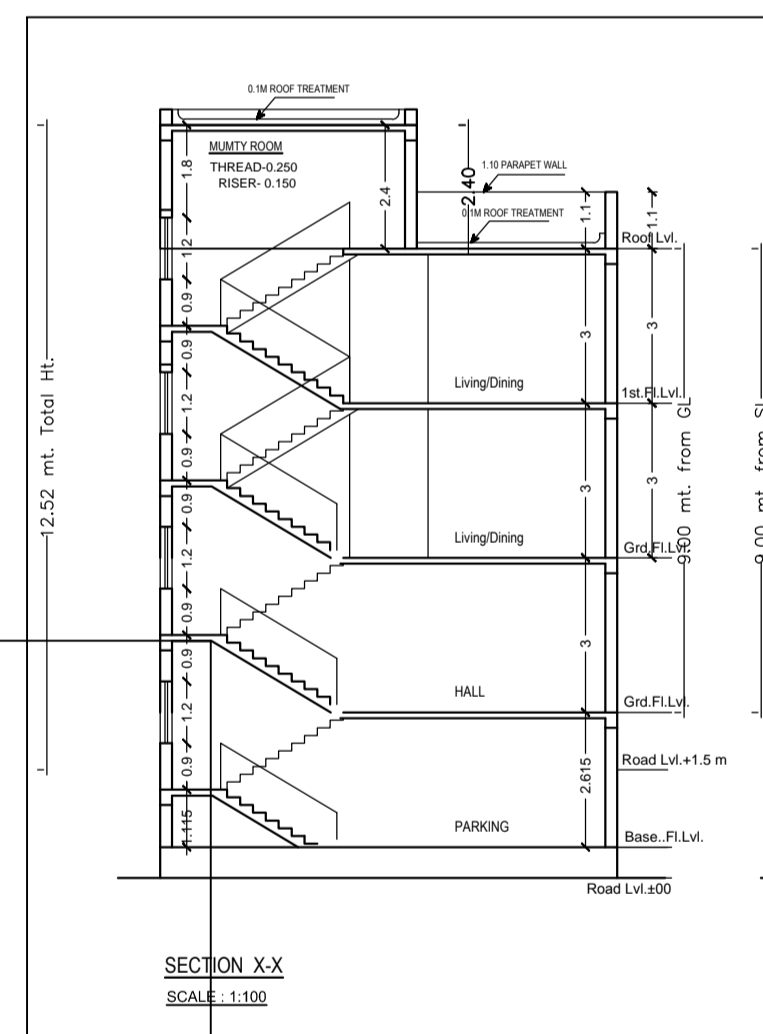
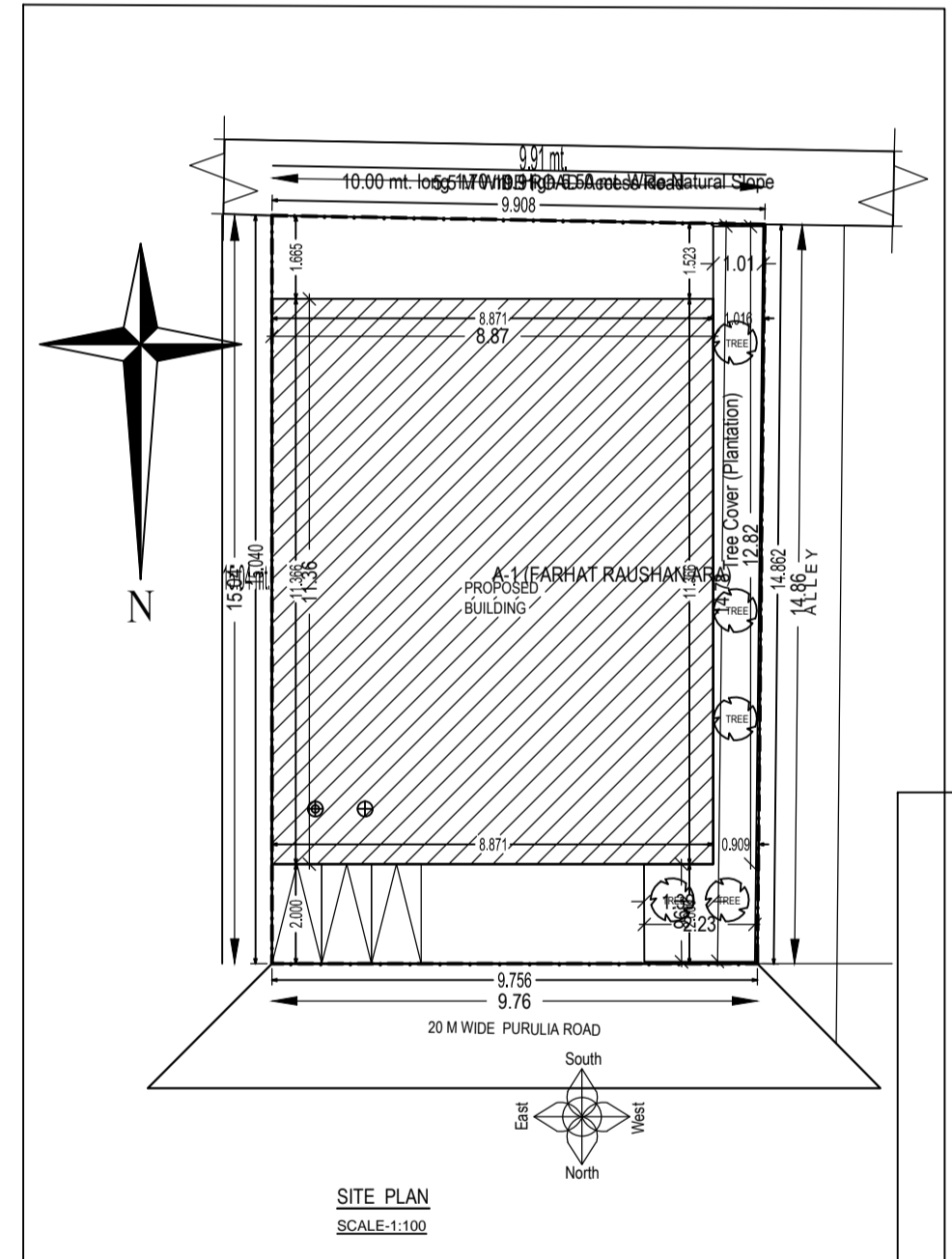
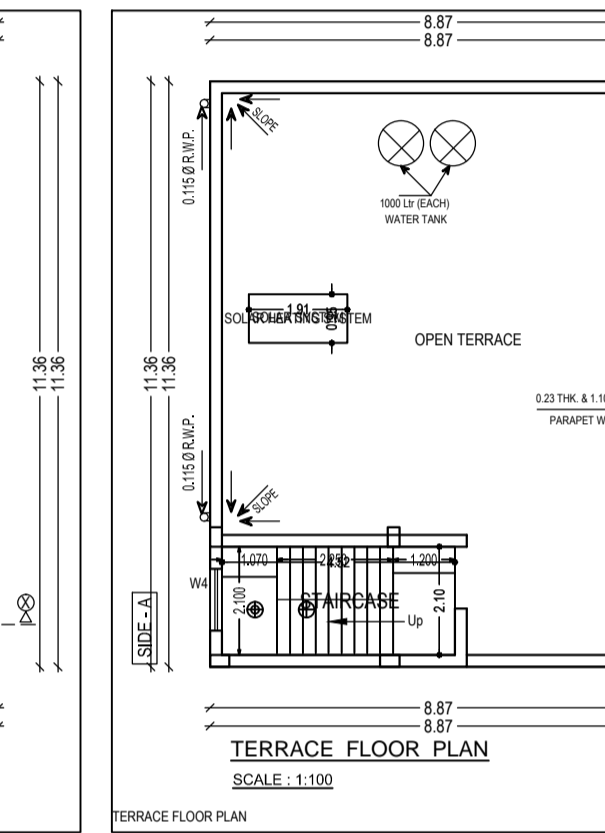
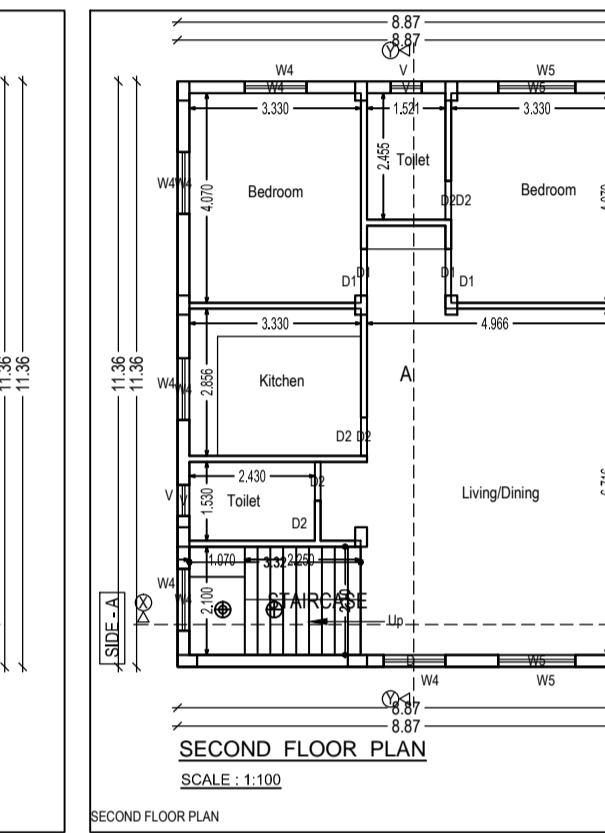
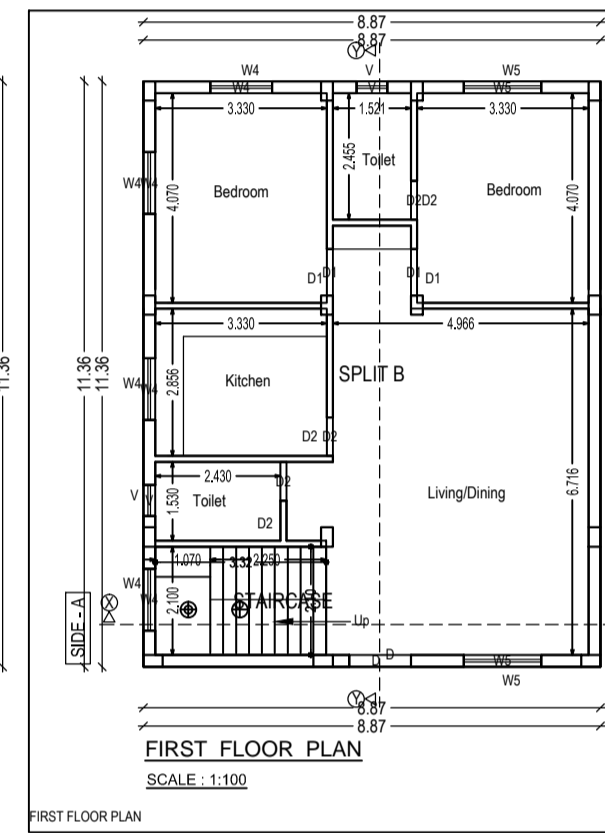
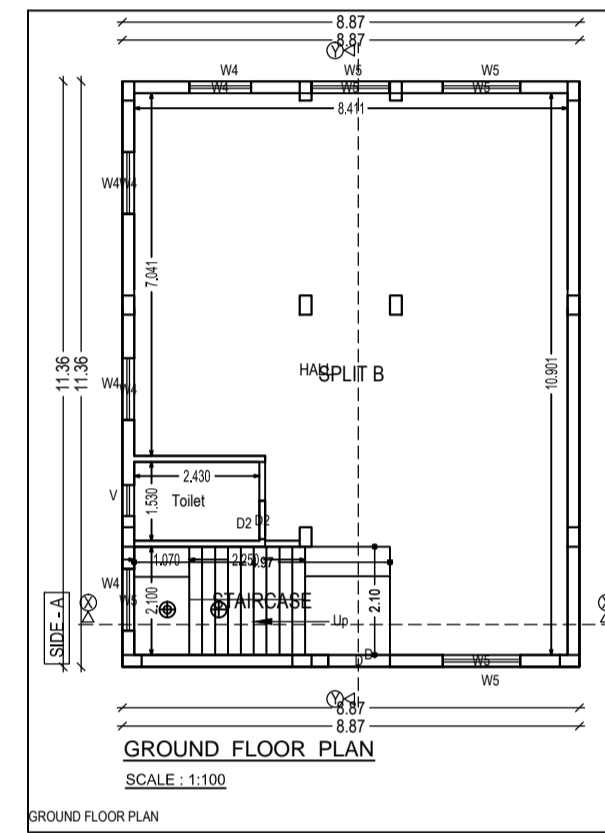
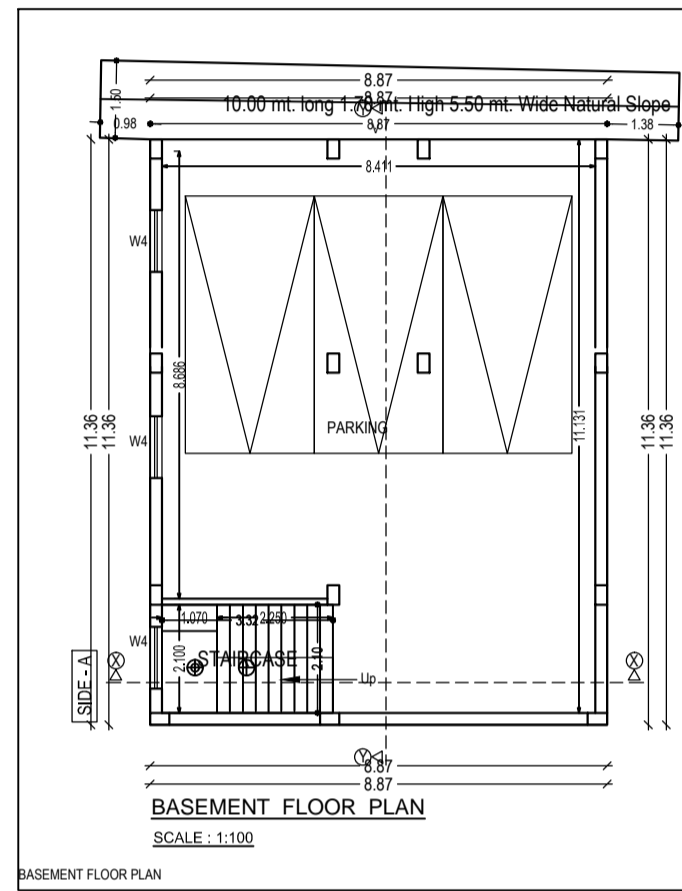

Building 'A' (FARHAT RAUSHAN ARA)						
Floor Name	Total Built Up Area (Sq.mt.)	Deductions Area in Sq.mt.	Proposed FAR Area (Sq.mt.)	Add Area in FAR (Sq.mt.)	Total FAR Area (Sq.mt.)	Tenent (No.)
Basement Floor	100.79	93.81	0.00	6.97	6.97	00
Ground Floor	100.79	0.00	100.79	0.00	100.79	01
First Floor	100.79	0.00	100.79	0.00	100.79	00
Second Floor	100.79	0.00	100.79	0.00	100.79	01
Terrace Floor	0.00	0.00	0.00	0.00	0.00	00
Total	403.16	93.81	302.37	6.97	309.34	02
Total Number of Same Buildings	1					
Total	403.16	93.81	302.37	6.97	309.34	02

SCHEDULE OF JOINERY:			
BUILDING NAME	NAME	LENGTH	HEIGHT
A1 FARHAT RAUSHAN ARA	D2	0.75	2.10
A1 FARHAT RAUSHAN ARA	D1	0.90	2.10
A1 FARHAT RAUSHAN ARA	D	2.10	2.10
A1 FARHAT RAUSHAN ARA	-	-	-
Total	-	-	14

SCHEDULE OF JOINERY:				
BUILDING NAME	NAME	LENGTH	HEIGHT	NOS
A1 FARHAT RAUSHAN ARA	V	0.60	1.00	04
A1 FARHAT RAUSHAN ARA	WS	1.20	1.20	01
A1 FARHAT RAUSHAN ARA	WS	1.20	1.20	11
A1 FARHAT RAUSHAN ARA	WS	1.50	1.20	07
Total	-	-	-	23

UnitBUA Table for Building 'A' (FARHAT RAUSHAN ARA)						
FLOOR	Name	UnitBUA Type	UnitBUA Area	Carpet Area	No. of Rooms	No. of Tenement
GROUND FLOOR PLAN	SPLIT B	FLAT	201.57	184.75	2	1
SECOND FLOOR PLAN	A	FLAT	100.79	91.32	8	1
Total	-	-	302.36	276.07	10	2