

Proposal Basic Information

Proposal File No.	MNAC/BP/0040/W10/2020
Owner Name	SUSHILA DEVI
Khata No	294
Plot No	3195 (P)
Village Name	Mango
Use	Residential
SubUse	Bungalow/ Dwelling / Non Apartment

AREA STATEMENT MANGO MUNICIPAL CORPORATION	VERSION NO.: 1.0.50	VERSION DATE: 16/10/2020
PROJECT DETAIL:		
Region: JHARKHAND URBAN LOCAL BODIES	Plot Use: Residential	
District: EAST SINGHBHUM	Plot SubUse: Bungalow/ Dwelling / Non Apartment	
Authority: MANGO MUNICIPAL CORPORATION	PlotNearbyReligiousStructure: NA	
Inward_No: MNAC/BP/0040/W10/2020	Plot/SubPlot No: 3195 (P)	
Application Type: General Proposal	North: Plot No. - 3195	
Project Type: Building Permission	South: Plot No. - 3195	
Nature of Development: New	East: Road Width - 3.40	
Location of Development Area: Old Area	West: Plot No. - 2476	
AREA DETAILS:		
AREA OF PLOT (Minimum)	(A)	82.29
Deduction for NetPlot Area		
Surrender Free of Cost		7.00
Total		7.00
NET AREA OF PLOT(Gross Plot Area - Deduction from Gross Plot area)	(A-Deductions)	75.29
Deduction for Balance Plot Area(from Gross Plot Area)		
Surrender Free of Cost		7.00
Common Plot		6.11
Total		13.11
BALANCE AREA OF PLOT(Net Plot Area - Recreational/Amenity space)	(A-Deductions)	69.18
PLOT AREA FOR COVERAGE(Net Plot Area)	(A-Deductions)	75.29
Plot Area for FAR (Net Plot Area + RoadWidening Area)	(A-Deductions)	82.29
COVERAGE CHECK		
Permissible Coverage area ( 70.00 % )		52.70
Proposed Coverage Area ( 65.70 % )		49.47
Total Prop. Coverage Area ( 65.7 % )		49.47
Balance coverage area ( 4.29 % )		3.23
FAR CHECK		
Perm. FAR Area ( 1.20 )		98.75
Total Perm. FAR area		98.75
Residential FAR		66.84
Proposed FAR Area		66.84
Total Proposed FAR Area		66.84
Consumed FAR (Factor)		0.81
Balance FAR Area		31.91
BUILT UP AREA CHECK		
Total Proposed BuiltUp Area		98.94
ARCHITECT (Regd)	Chandrika Sharma	
ENGINEER (Regd)		
SUPERVISOR (Regd)		
OWNER (Regd)	SUSHILA DEVI	
DEVELOPMENT AUTHORITY		LOCAL BODY

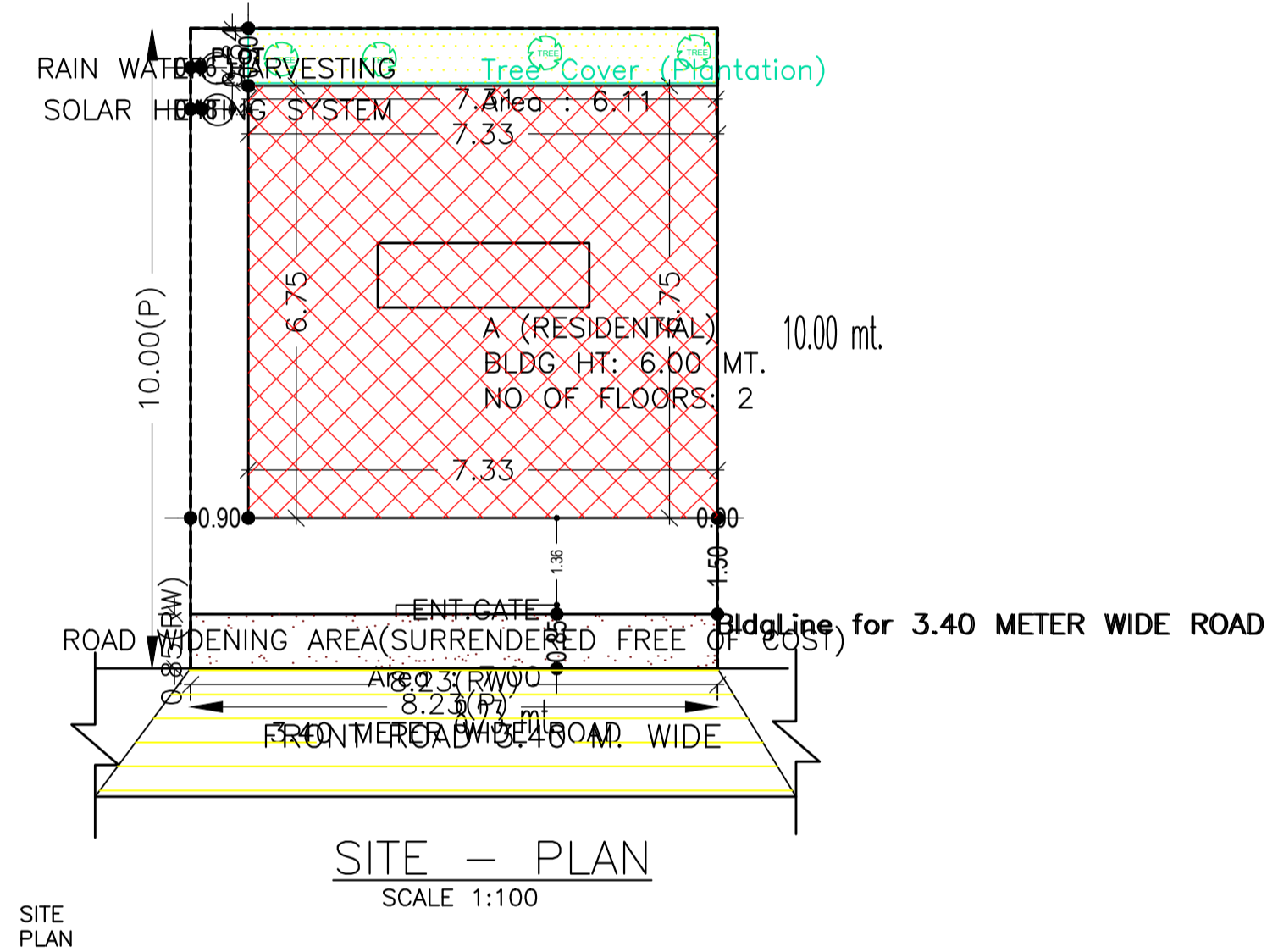

FAR & Tenement Details (Table 4c-1)

Building	No. of Same Bldg	Total Built Up Area (Sq.mt.)	Deductions (Area in Sq.mt.)		Proposed FAR Area (Sq.mt.)	Total FAR Area (Sq.mt.)	Total Consumed Additional FAR Area (Sq.mt.)	Trmt (No.)
			Parking	Resi.				
A (RESIDENTIAL)	1	98.94	32.09	66.85	66.85	66.85	01	
Grand Total :	1	98.94	32.09	66.85	66.85	66.85	01	

Building USE/SUBUSE Details

Building Name	Building Use	Building SubUse	Building Structure
A (RESIDENTIAL)	Residential	Bungalow/ Dwelling / Non Apartment	Non-Highrise

LTP NAME AND SIGNATURE	STRUCTURAL ENG'S NAME AND SIGNATURE	BUILDER NAME AND SIGNATURE	DIGITAL SIGNATURE
Chandrika Sharma MNAC/DFTMN/0017/2017			

Proposal Basic Information	
Proposal File No.	MNAC/BP/0040/W10/2020
Owner Name	SUSHILA DEVI
Khata No	294
Plot No	3195 (P)
Village Name	Mango
Use	Residential
SubUse	Bungalow/ Dwelling / Non Apartment

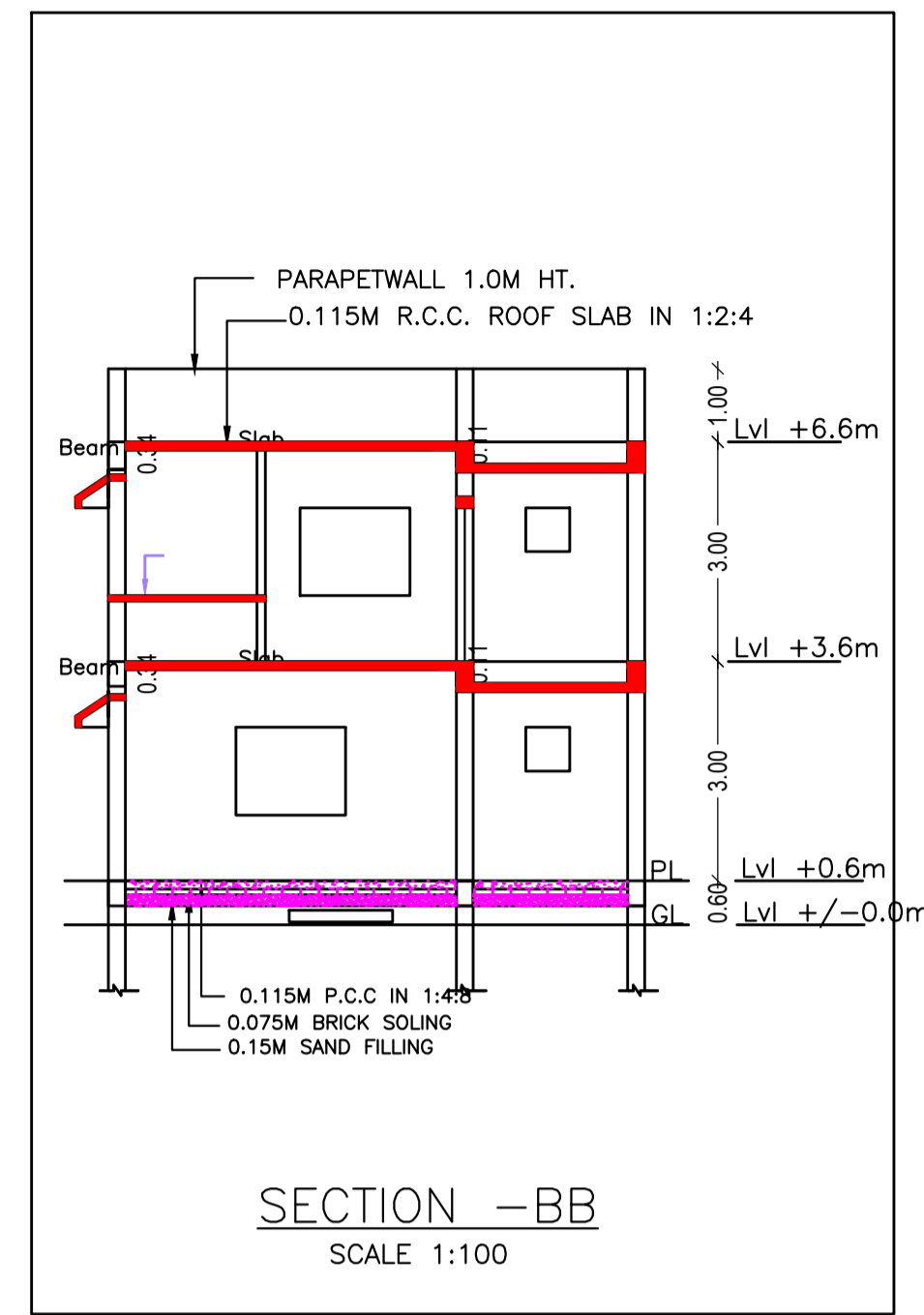
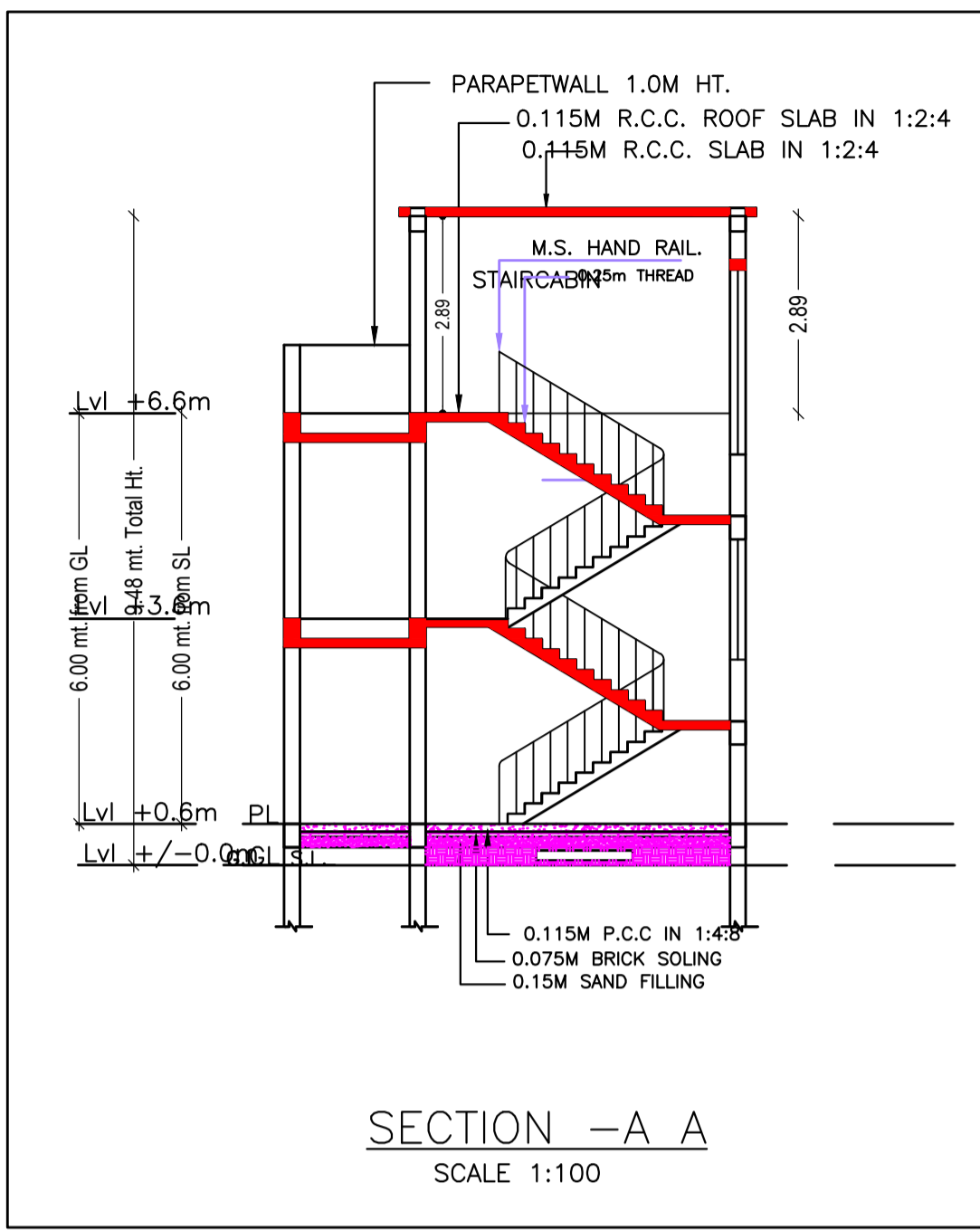
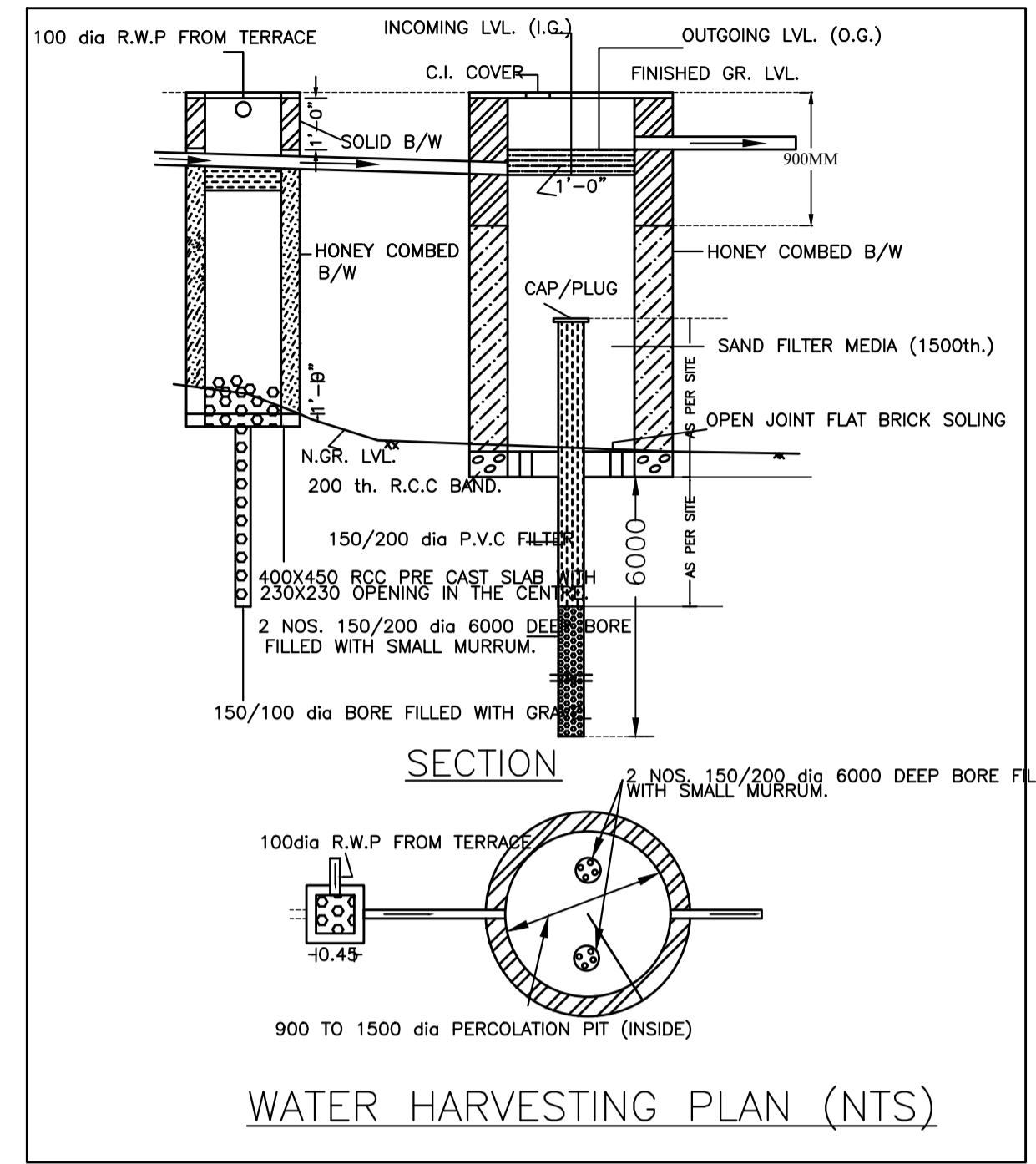
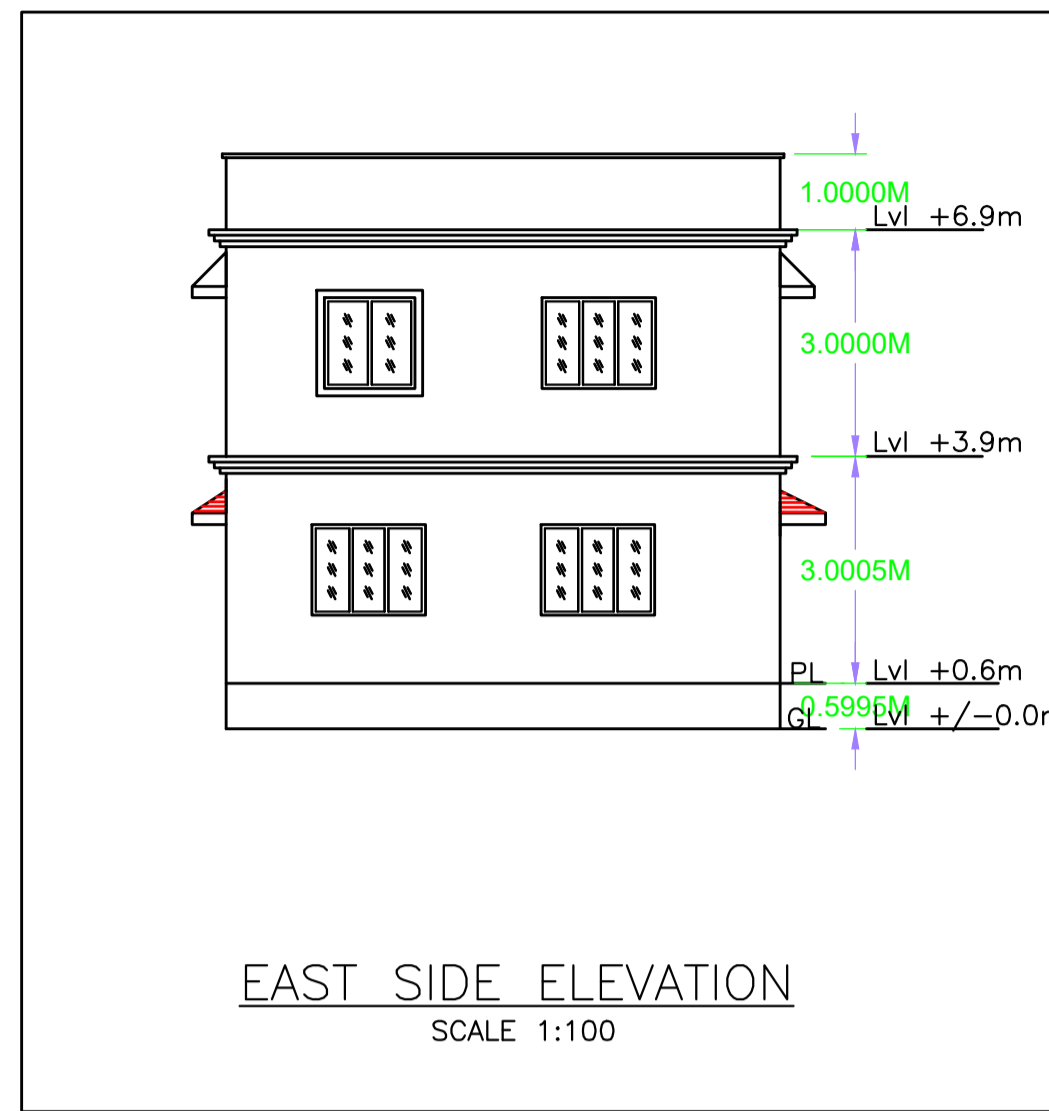

**SCHEDULE OF DOOR:**

BUILDING NAME	NAME	LENGTH	HEIGHT	NOS
A (RESIDENTIAL)	D2	0.75	2.10	02
A (RESIDENTIAL)	D1	0.90	2.10	01
A (RESIDENTIAL)	D	1.00	2.10	01
A (RESIDENTIAL)	D	1.20	2.10	01

**SCHEDULE OF WINDOW/VENTILATION:**

BUILDING NAME	NAME	LENGTH	HEIGHT	NOS
A (RESIDENTIAL)	V	0.60	0.90	02
A (RESIDENTIAL)	W1	1.20	1.20	01
A (RESIDENTIAL)	W	1.50	1.20	03

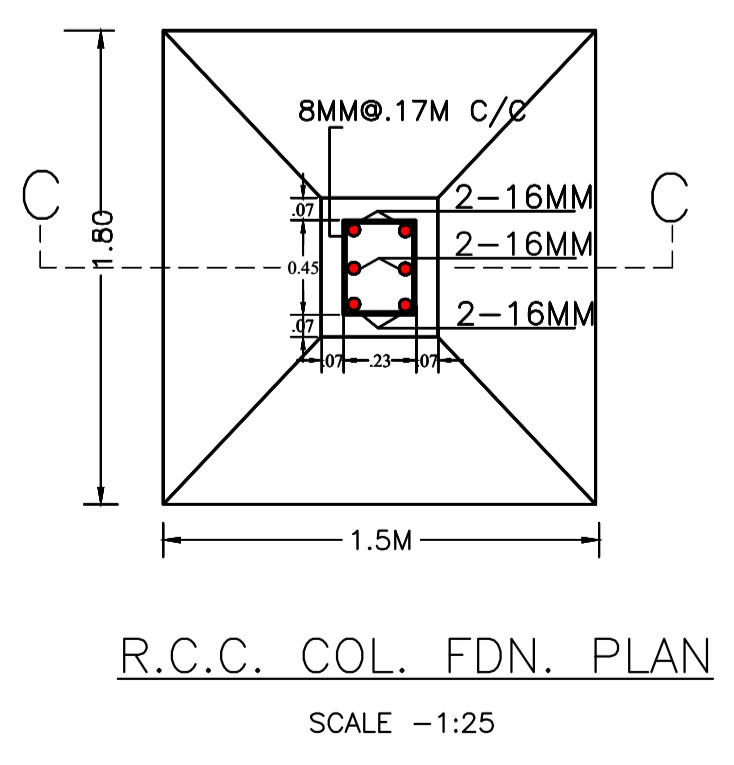
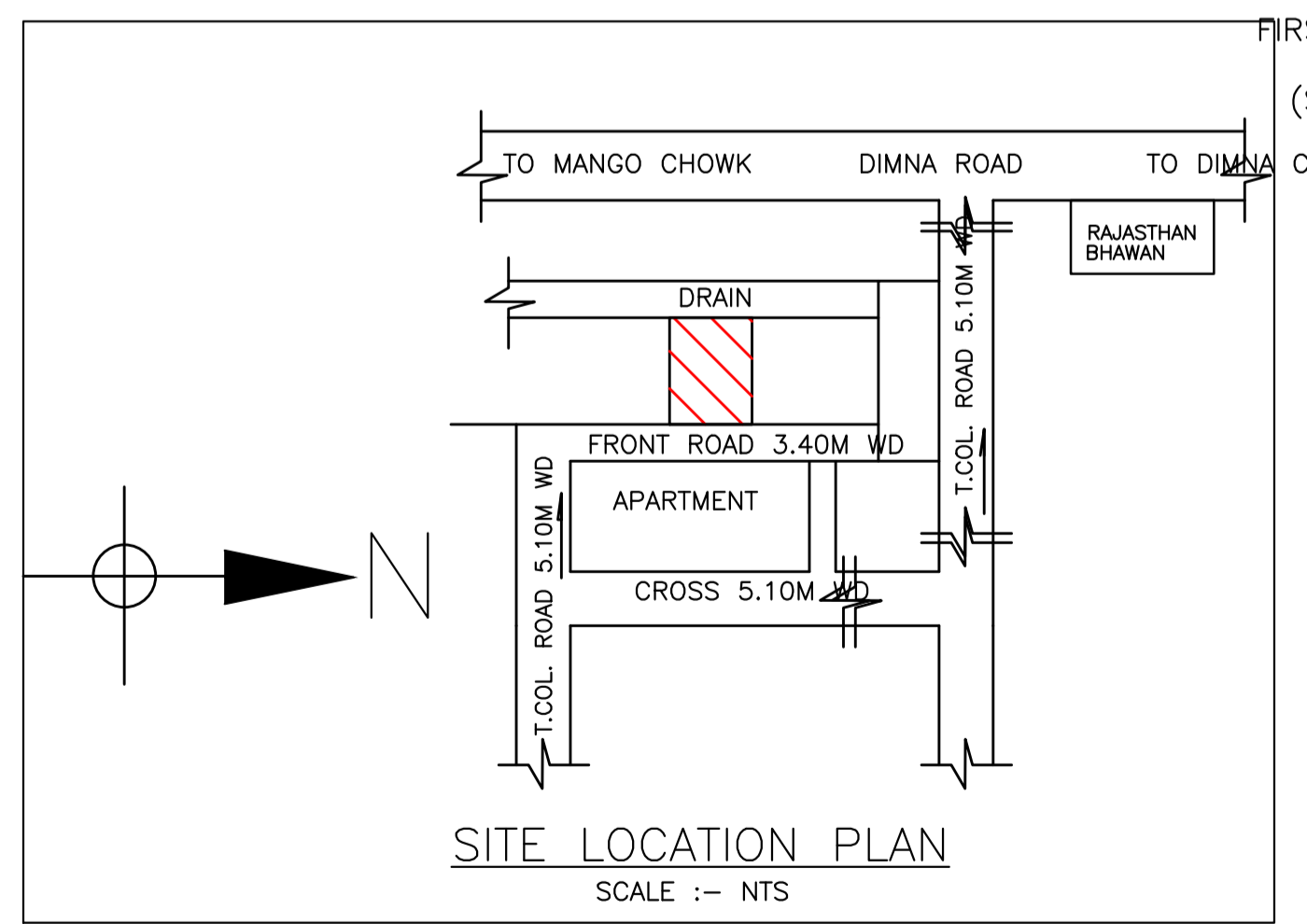
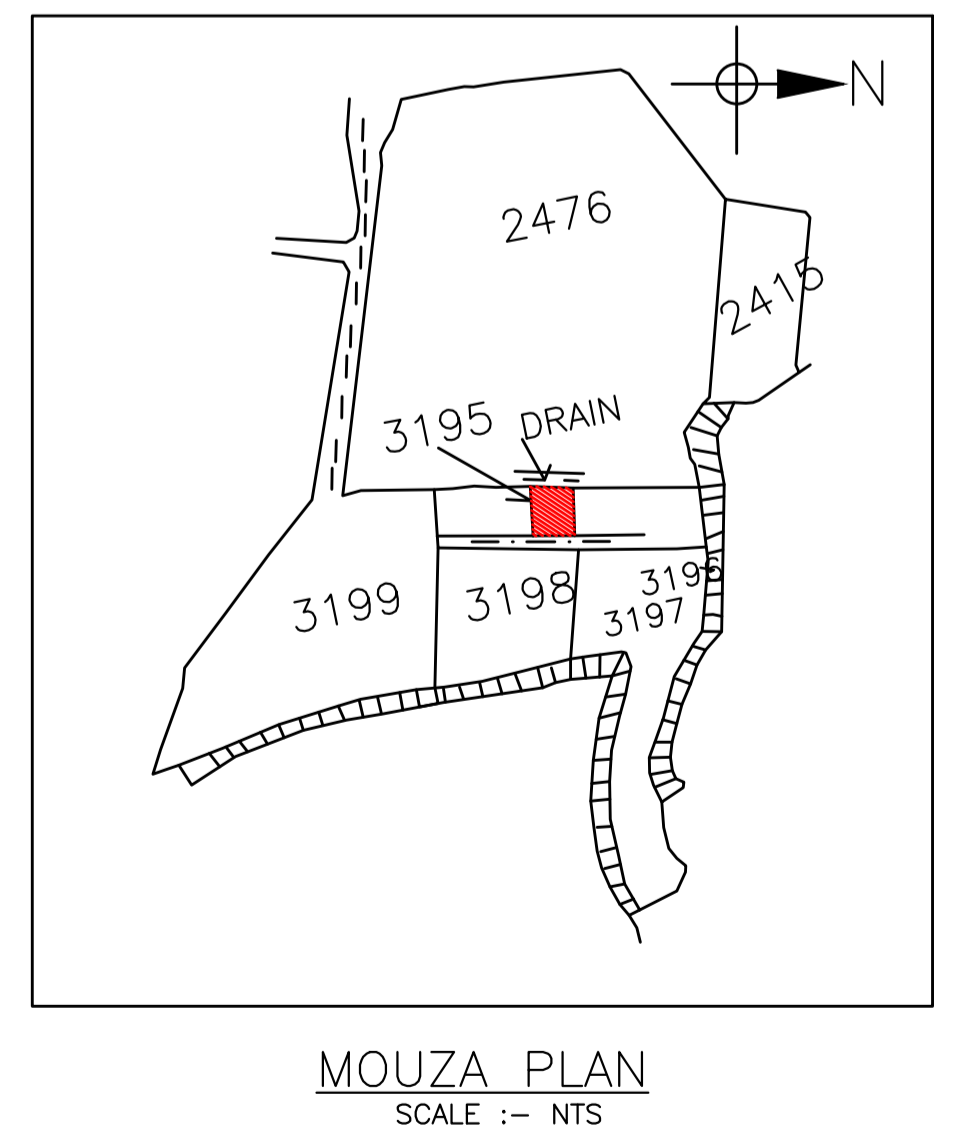
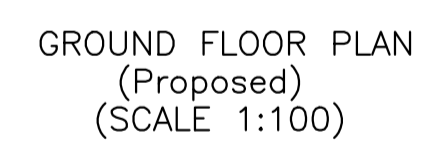
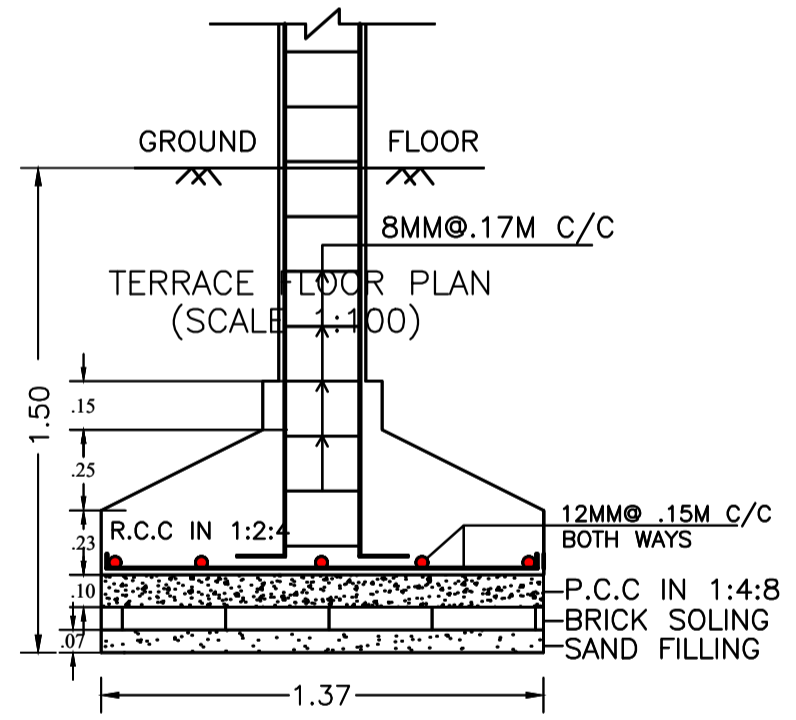
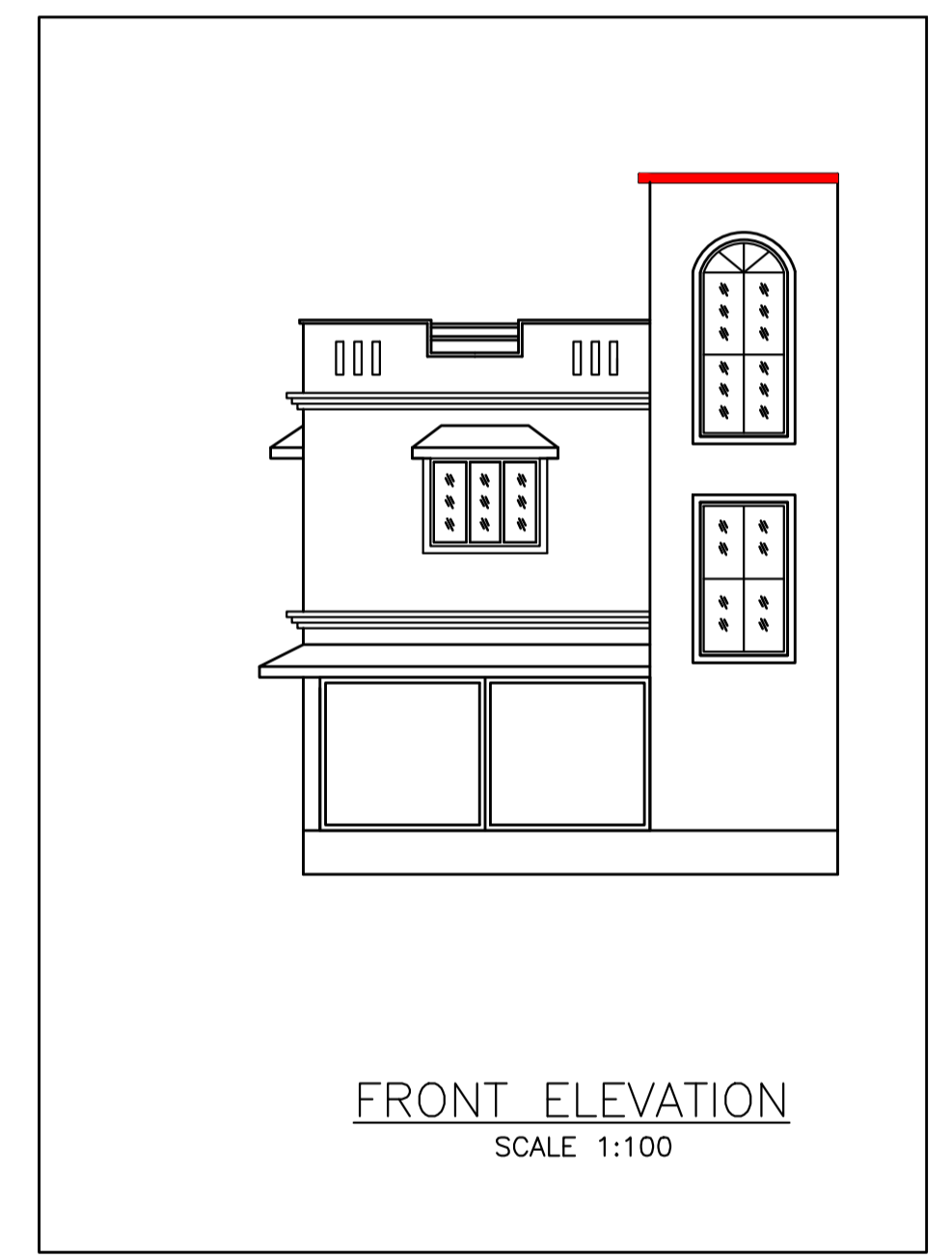
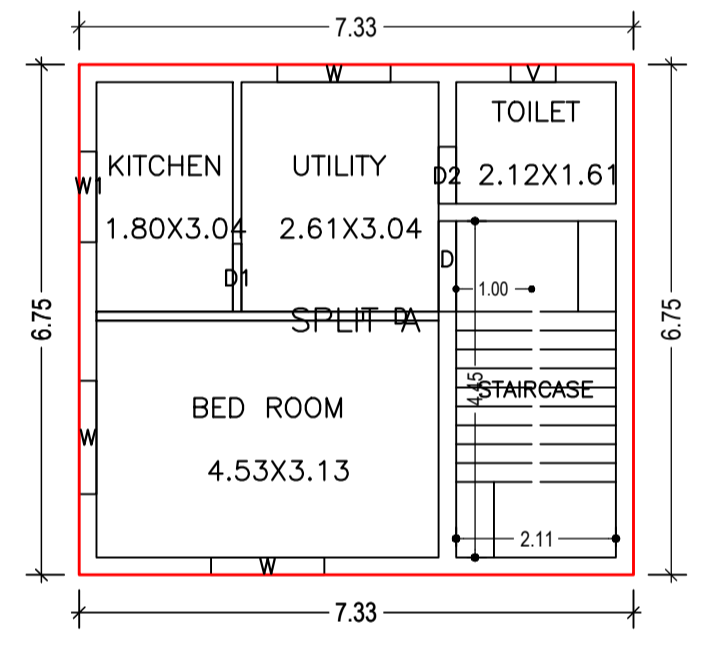
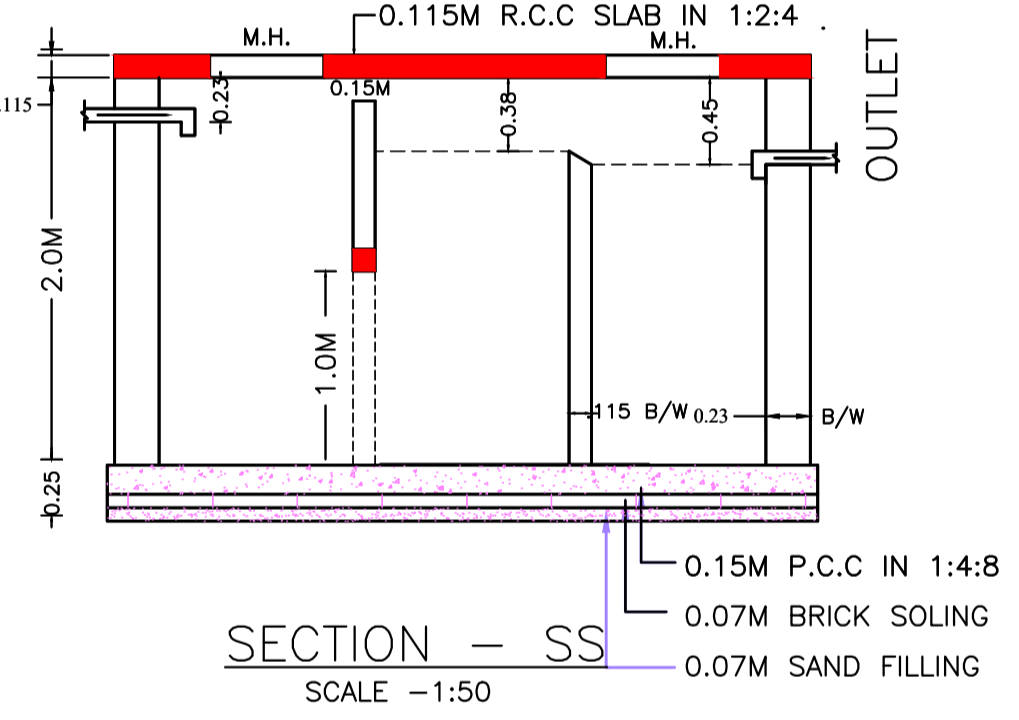
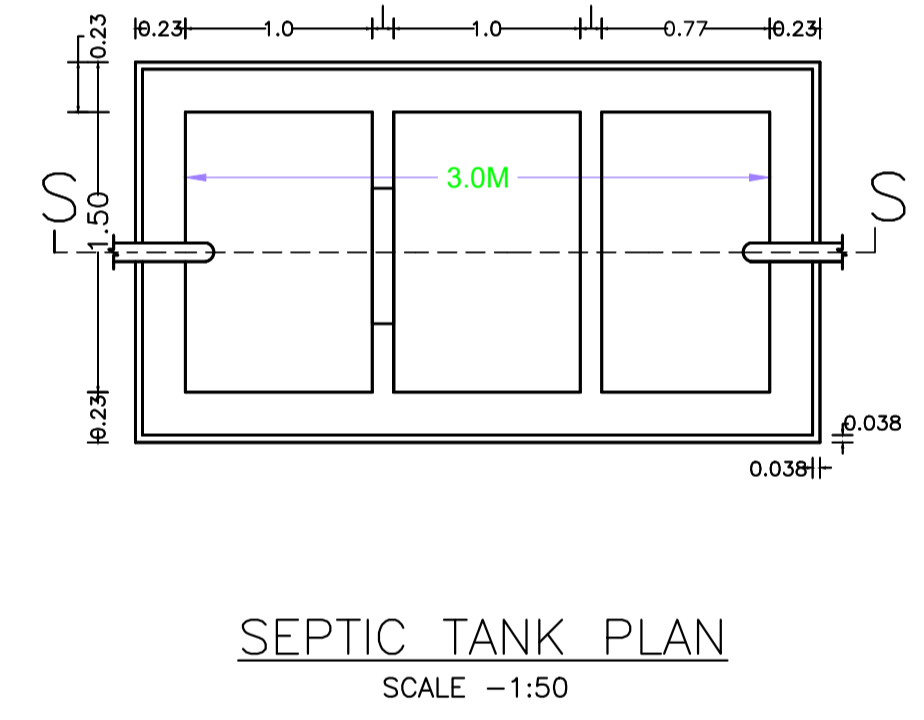
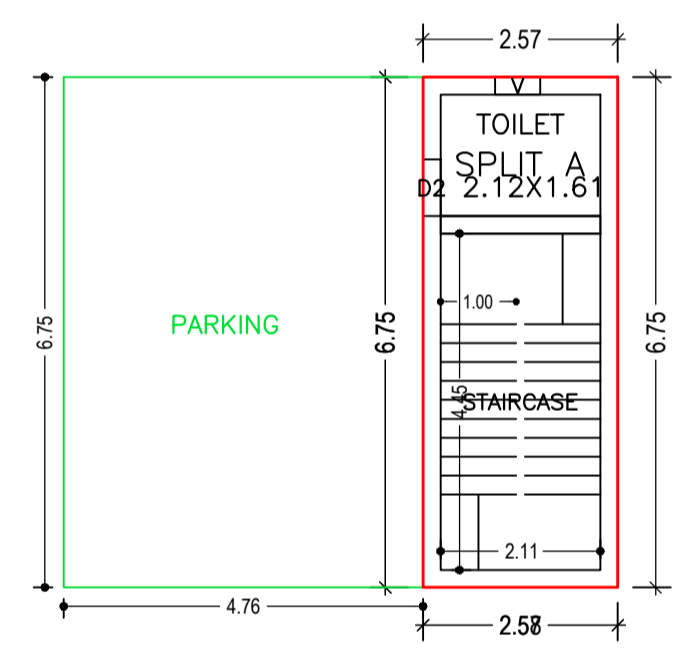
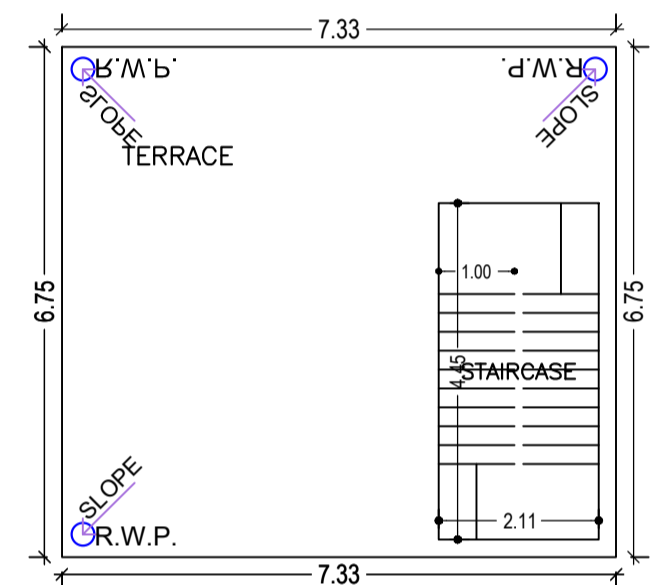

**Building :A (RESIDENTIAL)**

Floor Name	Total Built Up Area (Sq.mt.)	Deductions (Area in Sq.mt.)	Proposed FAR Area (Sq.mt.)	Total FAR Area (Sq.mt.)	Total Consumed Additional FAR Area (Sq.mt.)	Trmt (No.)
Ground Floor	49.47	32.09	17.38	17.38	17.38	01
First Floor	49.47	0.00	49.47	49.47	49.47	00
Terrace Floor	0.00	0.00	0.00	0.00	0.00	00
<b>Total :</b>	<b>98.94</b>	<b>32.09</b>	<b>66.85</b>	<b>66.85</b>	<b>66.85</b>	<b>01</b>
Total Number of Same Buildings :	1					
<b>Total :</b>	<b>98.94</b>	<b>32.09</b>	<b>66.85</b>	<b>66.85</b>	<b>66.85</b>	<b>01</b>

**UnitBUA Table for Building :A (RESIDENTIAL)**

FLOOR	Name	UnitBUA Type	UnitBUA Area	Carpet Area	No. of Rooms	No. of Tenement
GROUND FLOOR PLAN	SPLIT A	FLAT	36.11	35.22	1	1
FIRST FLOOR PLAN	SPLIT A	FLAT	0.00	0.00	4	0
<b>Total:</b>	-	-	<b>36.11</b>	<b>35.22</b>	<b>5</b>	<b>1</b>

LTP NAME AND SIGNATURE	STRUCTURAL ENG'S NAME AND SIGNATURE	BUILDER NAME AND SIGNATURE	DIGITAL SIGNATURE
Chandrika Sharma MNAC/DFTMN/0017/2017			