

AREA STATEMENT MANGO MUNICIPAL CORPORATION	VERSION NO.: 1.0.50		
	VERSION DATE: 16/10/2020		
PROJECT DETAIL:			
Region: JHARKHAND URBAN LOCAL BODIES	Plot Use: Residential		
District: EAST SINGHBHUM	Plot SubUse: Bungalow/ Dwelling / Non Apartment		
Authority: MANGO MUNICIPAL CORPORATION	PlotNearby/ReligiousStructure: NA		
Inward No: MNAC/BP/0044/W10/2020	Plot/SubPlot No: 3772		
Application Type: General Proposal	North: Road Width - 3.66		
Project Type: Building Permission	South: Survey No. - Other Plot		
Nature of Development: New	East: Survey No. - Other Plot		
Location of Development Area: Old Area	West: Survey No. - Other Plot		
AREA DETAILS:			
AREA OF PLOT (Minimum)	(A)	SQ.MT.	340.14
NET AREA OF PLOT(Gross Plot Area - Deduction from Gross Plot area)	(A-Deductions)		340.14
Deduction for Balance Plot Area(from Gross Plot Area)			
Common Plot			49.58
Total			49.58
BALANCE AREA OF PLOT(Net Plot Area - Recreational/Amenity space)	(A-Deductions)		290.56
PLOT AREA FOR COVERAGE(Net Plot Area)	(A-Deductions)		340.14
Plot Area for FAR (Net Plot Area + RoadWidening Area)	(A-Deductions)		340.14
COVERAGE CHECK			
Permissible Coverage area ( 60.00 % )			204.08
Proposed Coverage Area ( 43.66 % )			148.51
Balance coverage area ( 16.34 % )			55.57
FAR CHECK			
Perm. FAR Area ( 1.50 )			510.21
Total Perm. FAR area			510.21
Residential FAR			297.01
Proposed FAR Area			297.01
Total Proposed FAR Area			297.01
Consumed FAR (Factor)			0.87
Balance FAR Area			213.20
BUILT UP AREA CHECK			
Total Proposed BuiltUp Area			297.02
ARCHITECT (Regd)			GAURI SHANKAR SAHU
ENGINEER (Regd)			
SUPERVISOR (Regd)			
OWNER (Regd)			KRISHNA MANI DEVI
DEVELOPMENT AUTHORITY		LOCAL BODY	

COLOR INDEX	
PLOT BOUNDARY	Black
ABUTTING ROAD	Green
PROPOSED CONSTRUCTION	Red
COMMON PLOT	Yellow
ROAD WIDENING AREA	Blue
EXISTING (To be retained)	Orange
EXISTING (To be demolished)	Grey

Buildingwise Floor FAR Details

Floor Name	Building Name		Total	
	A (KRISHNA MANI DEVI)		Total Proposed Built Up Area (Sq.mt.)	Total FAR Area (Sq.mt.)
Ground Floor	148.51	148.51	148.51	148.51
First Floor	148.51	148.51	148.51	148.51
Terrace Floor	0.00	0.00	0.00	0.00
Total :	297.02	297.02	297.02	297.02

Building USE/SUBUSE Details

Building Name	Building Use	Building SubUse	Building Structure
A (KRISHNA MANI DEVI)	Residential		Non-Highrise

Required Parking(Table 7a)

Building Name	Type	SubUse	Units		Car		Visitors Car			
			Reqd.	Prop.	Reqd./Unit	Reqd.	Prop.	Reqd./Unit	Reqd.	Prop.
A (KRISHNA MANI DEVI)	Residential	Bungalow/ Dwelling / Non Apartment	> 0	2.00	1.00	2	-	-	-	
			> 0	1	2.00	-	-	1	-	
Total :			-	-	-	2	3	-	1	1

Parking Check (Table 7b)

Vehicle Type	Reqd.		Prop.	
	No.	Area	No.	Area
Car	-	-	3	37.50
Total Car	2	25.00	3	37.50
Visitor's Car Parking	-	-	1	12.50
Total Visitor Parking	1	12.50	1	12.50
Total		37.50		50.00

FAR & Tenement Details (Table 4c-1)

Building	No. of Same Bldg	Total Built Up Area (Sq.mt.)	Proposed FAR Area (Sq.mt.)	Total FAR Area (Sq.mt.)	Total Consumed Additional FAR Area (Sq.mt.)	Tnmt (No.)
A (KRISHNA MANI DEVI)	1	297.02	297.02	297.02	297.02	02
Grand Total :	1	297.02	297.02	297.02	297.02	02

SITE PLAN

LTP NAME AND SIGNATURE	STRUCTURAL ENG'S NAME AND SIGNATURE	BUILDER NAME AND SIGNATURE	DIGITAL SIGNATURE
GAURI SHANKAR SAHU MNAC/ENG/0025/2017			

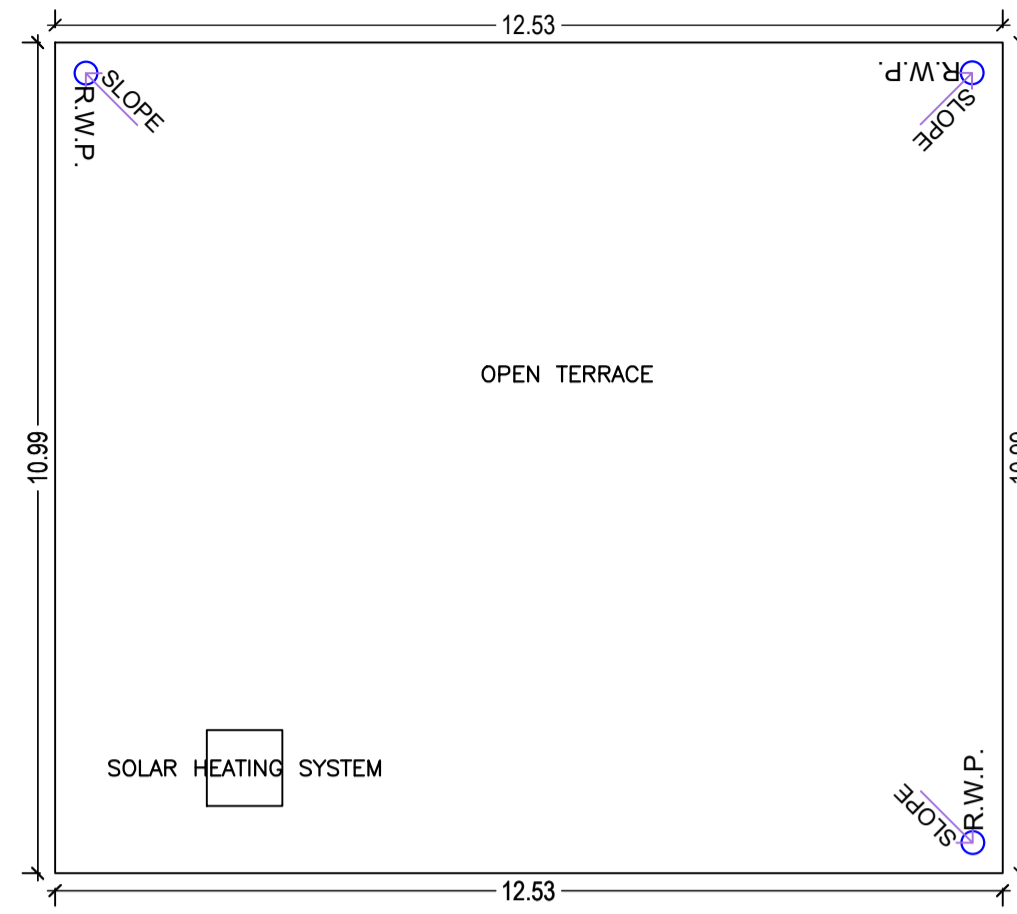

TERRACE FLOOR PLAN  
(SCALE 1:100)

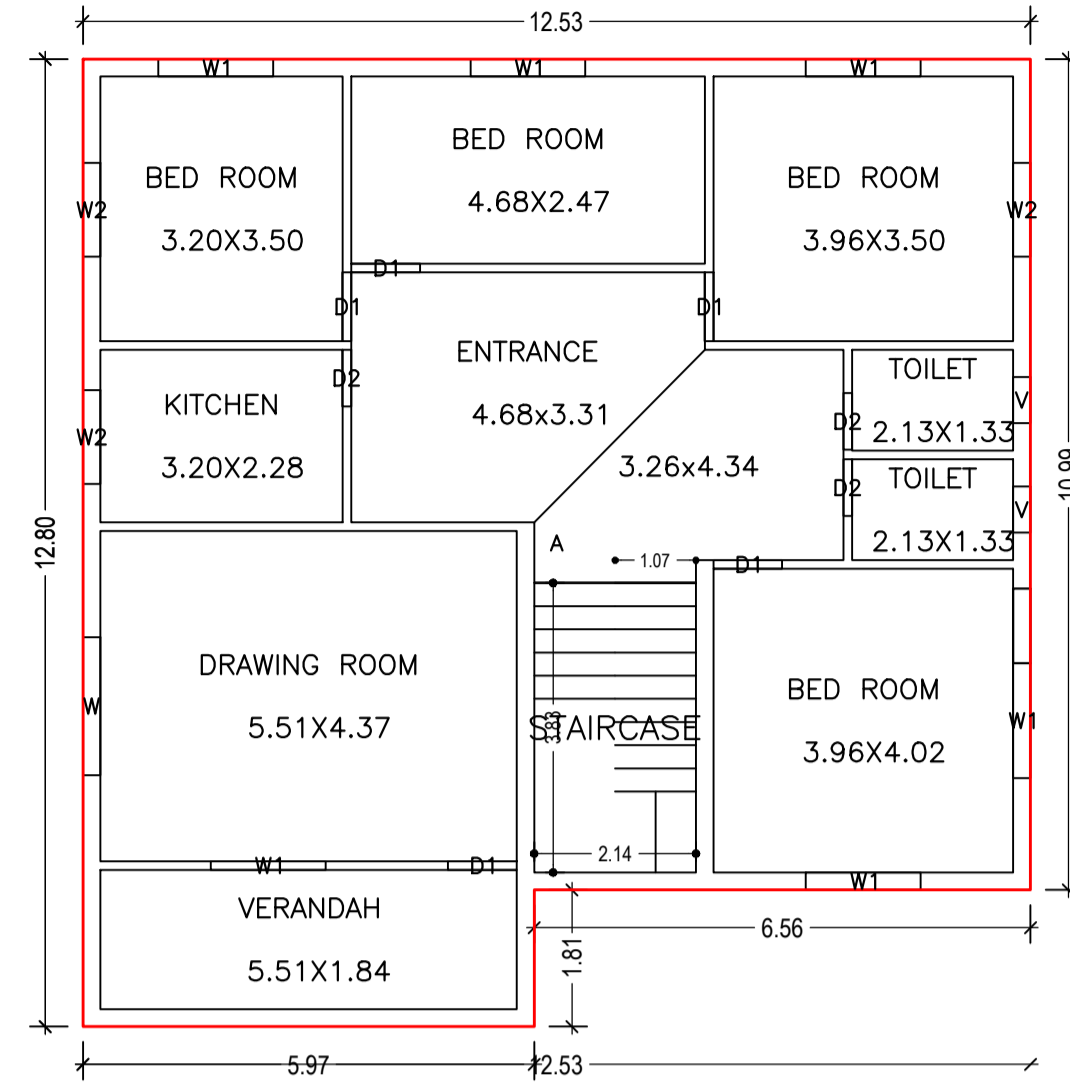

GROUND FLOOR PLAN  
(Proposed)  
(SCALE 1:100)

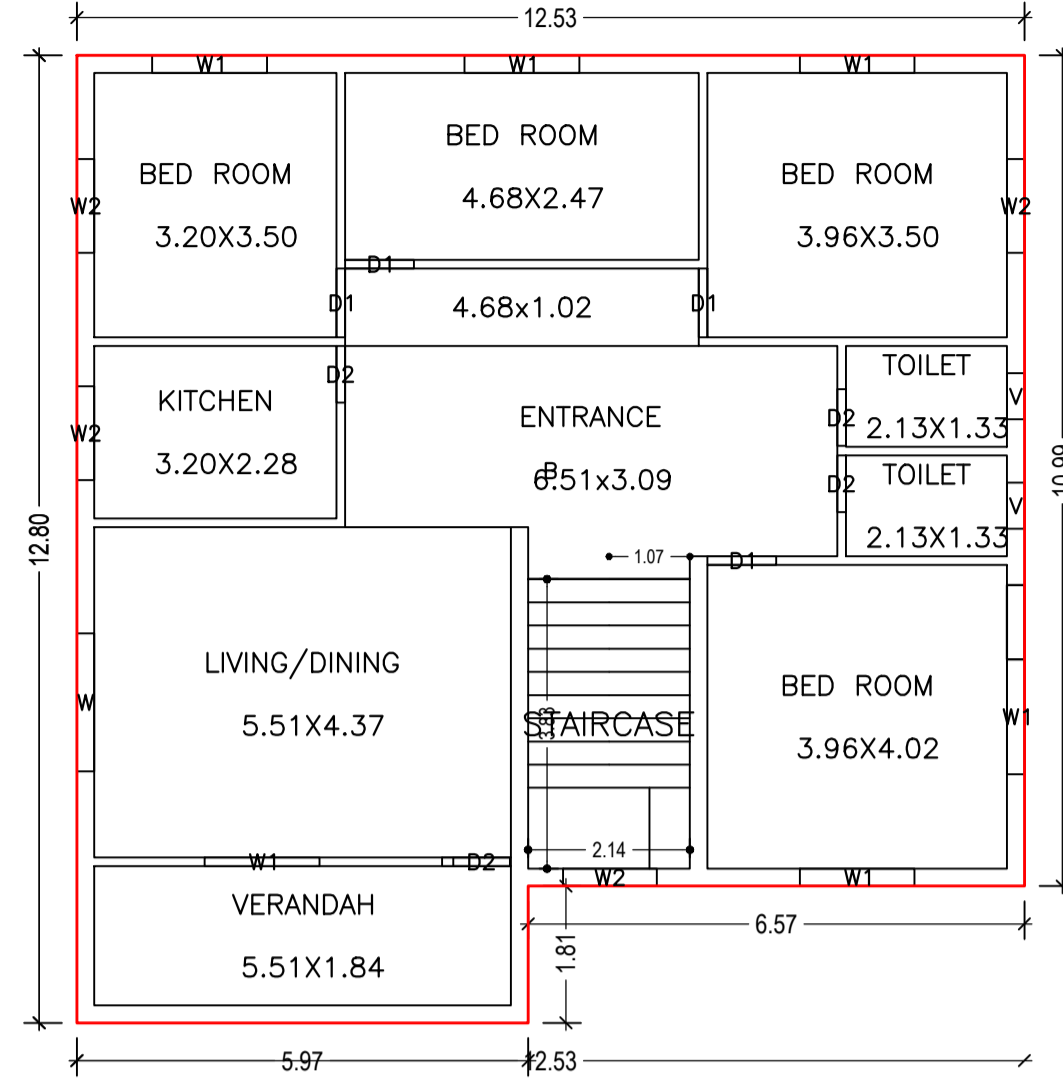

FIRST FLOOR PLAN  
(Proposed)  
(SCALE 1:100)

Building :A (KRISHNA MANI DEVI)

Floor Name	Total Built Up Area (Sq.mt.)	Proposed FAR Area (Sq.mt.) Resi.	Total FAR Area (Sq.mt.)	Total Consumed Additional FAR Area (Sq.mt.)	Tnmt (No.)
Ground Floor	148.51	148.51	148.51	148.51	01
First Floor	148.51	148.51	148.51	148.51	01
Terrace Floor	0.00	0.00	0.00	0.00	00
Total :	297.02	297.02	297.02	297.02	02
Total Number of Same Buildings :	1				
Total :	297.02	297.02	297.02	297.02	02

SCHEDULE OF DOOR:

BUILDING NAME	NAME	LENGTH	HEIGHT	NOS
A (KRISHNA MANI DEVI)	D2	0.75	2.10	07
A (KRISHNA MANI DEVI)	D1	0.91	2.10	09
A (KRISHNA MANI DEVI)	D2	0.91	2.10	01

SCHEDULE OF WINDOW/VENTILATION:

BUILDING NAME	NAME	LENGTH	HEIGHT	NOS
A (KRISHNA MANI DEVI)	V	0.61	0.60	04
A (KRISHNA MANI DEVI)	W2	1.24	1.20	07
A (KRISHNA MANI DEVI)	W1	1.52	1.20	12
A (KRISHNA MANI DEVI)	W	1.82	1.20	02

Proposal Basic Information

Proposal File No.	MNAC/BP/0044/W10/2020
Owner Name	KRISHNA MANI DEVI
Khata No	82
Plot No	3772
Village Name	Mango
Use	Residential
SubUse	Bungalow/ Dwelling / Non Apartment

LTP NAME AND SIGNATURE	STRUCTURAL ENG'S NAME AND SIGNATURE	BUILDER NAME AND SIGNATURE	DIGITAL SIGNATURE
GAURI SHANKAR SAHU MNAC/ENG/0025/2017			

MUMTY LVL +8.75M

UnitBUA Table for Building :A (KRISHNA MANI DEV)

FLOOR	Name	UnitBUA Type	UnitBUA Area	Carpet Area	No. of Rooms	No. of Tenement
TERRACE						
FLOOR PLAN	A	FLAT	148.51	148.28	10	1
FIRST FLOOR PLAN	B	FLAT	148.51	148.28	10	1
Total:			297.02	296.56	20	2

SIDE ELEVATION

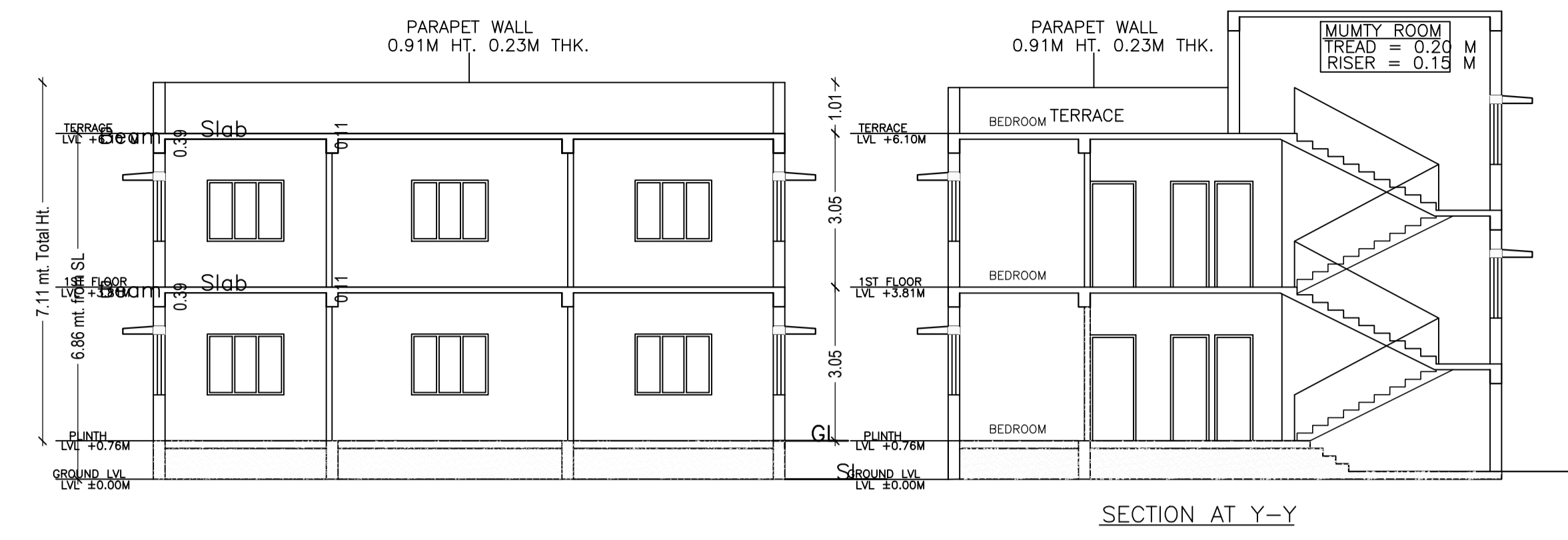

Proposal Basic Information

Proposal File No.	MNAC/BP/0044/W10/2020
Owner Name	KRISHNA MANI DEVI
Khata No	82
Plot No	3772
Village Name	Mango
Use	Residential
SubUse	Bungalow/ Dwelling / Non Apartment

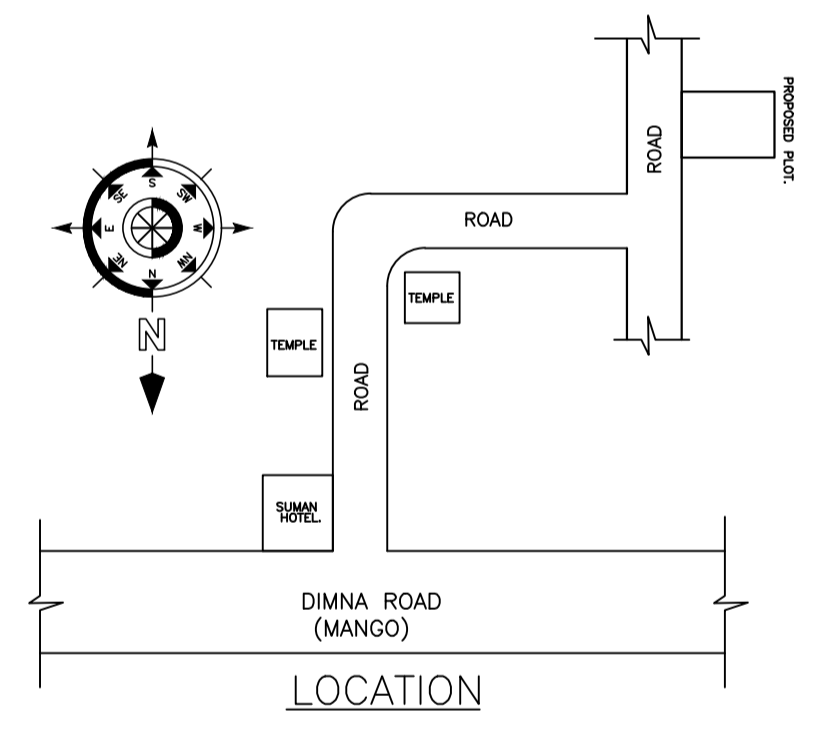
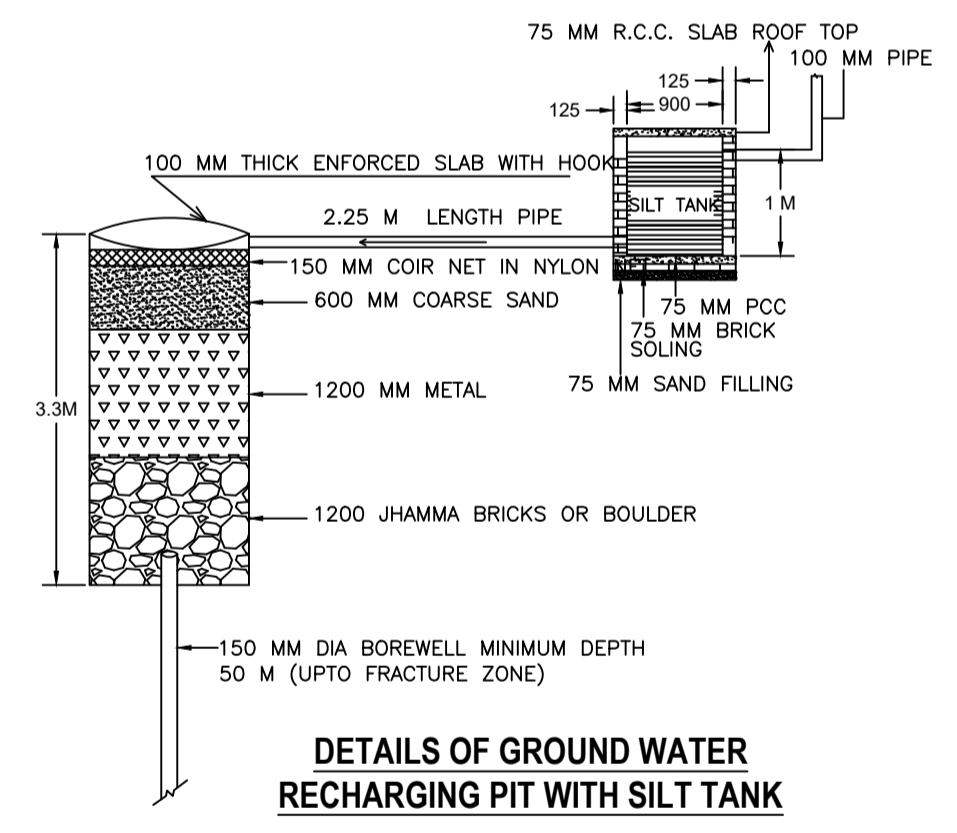
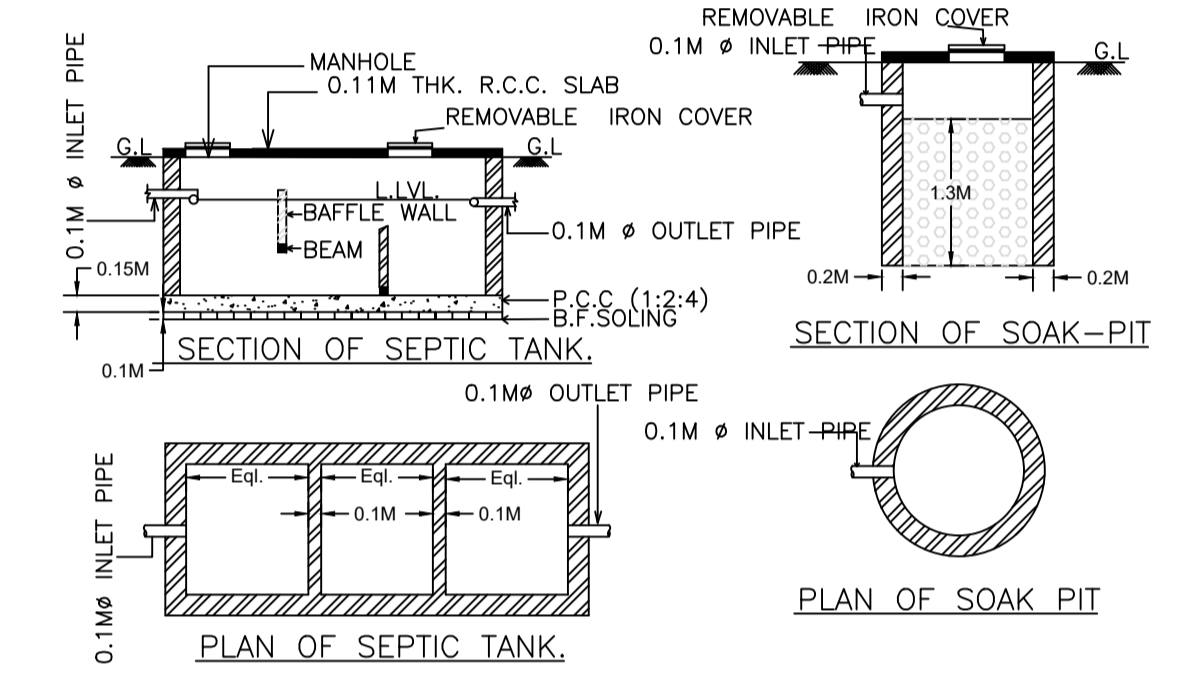
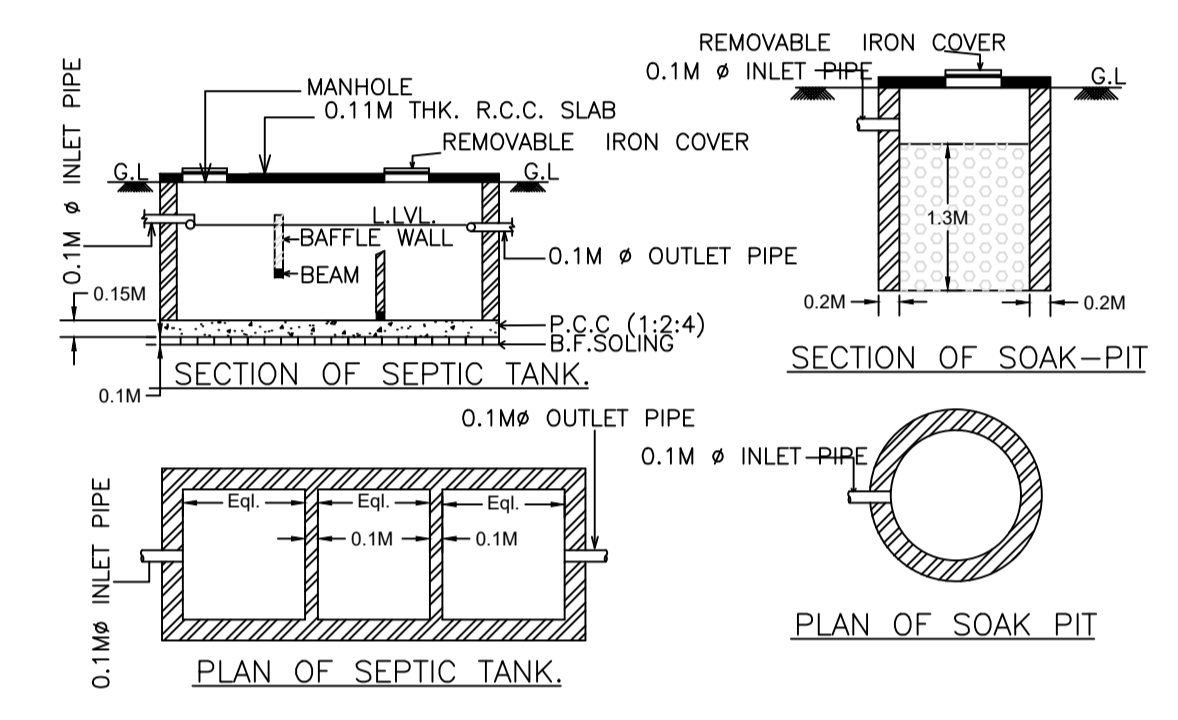
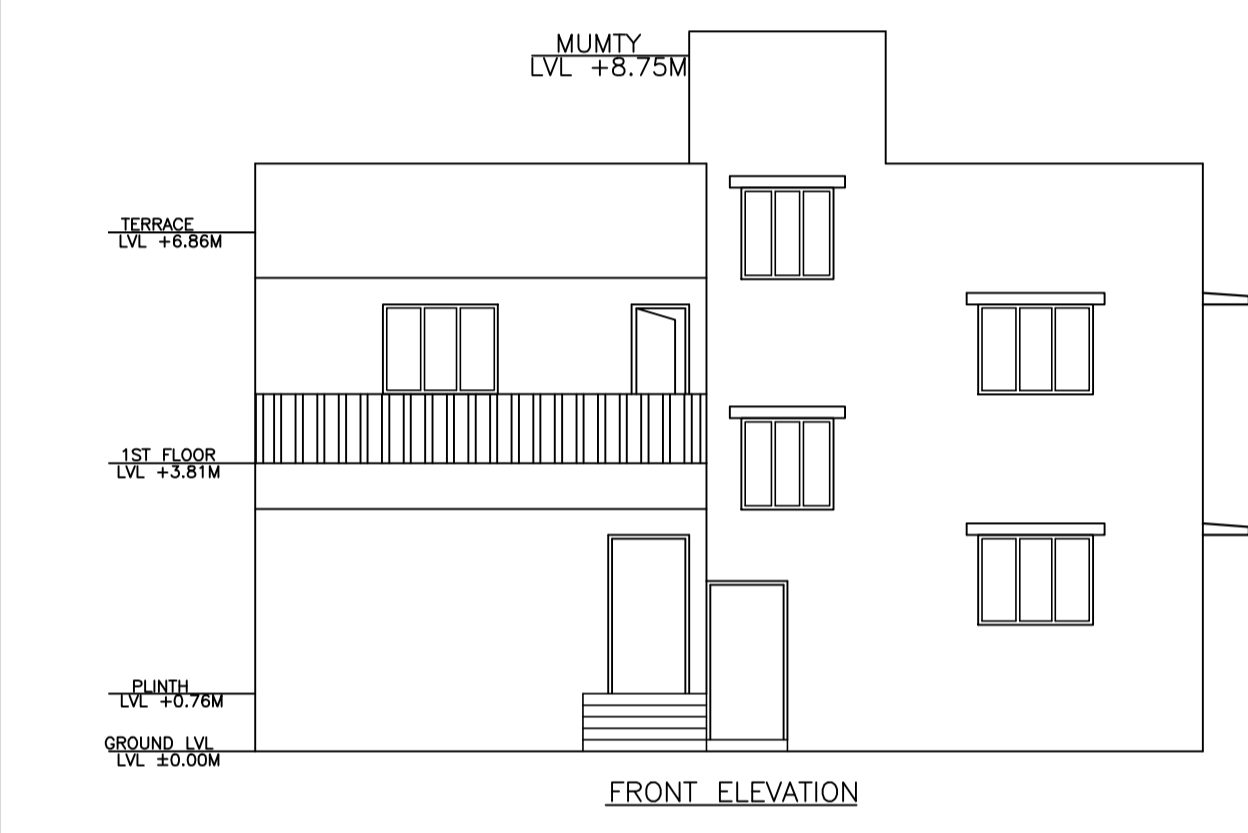

LTP NAME AND SIGNATURE	STRUCTURAL ENG'S NAME AND SIGNATURE	BUILDER NAME AND SIGNATURE	DIGITAL SIGNATURE
GAURI SHANKAR SAHU MNAC/ENG/0025/2017			