

Project Title : ANAND KUMAR PANDEY

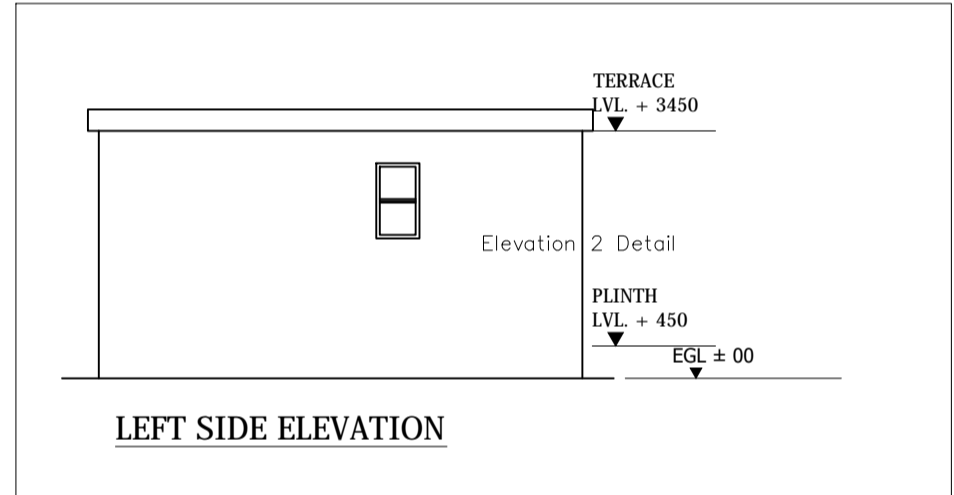
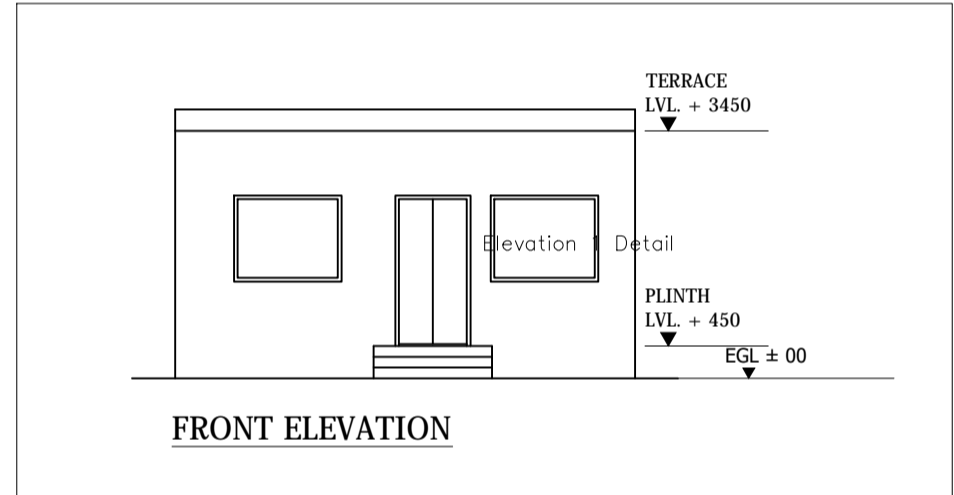
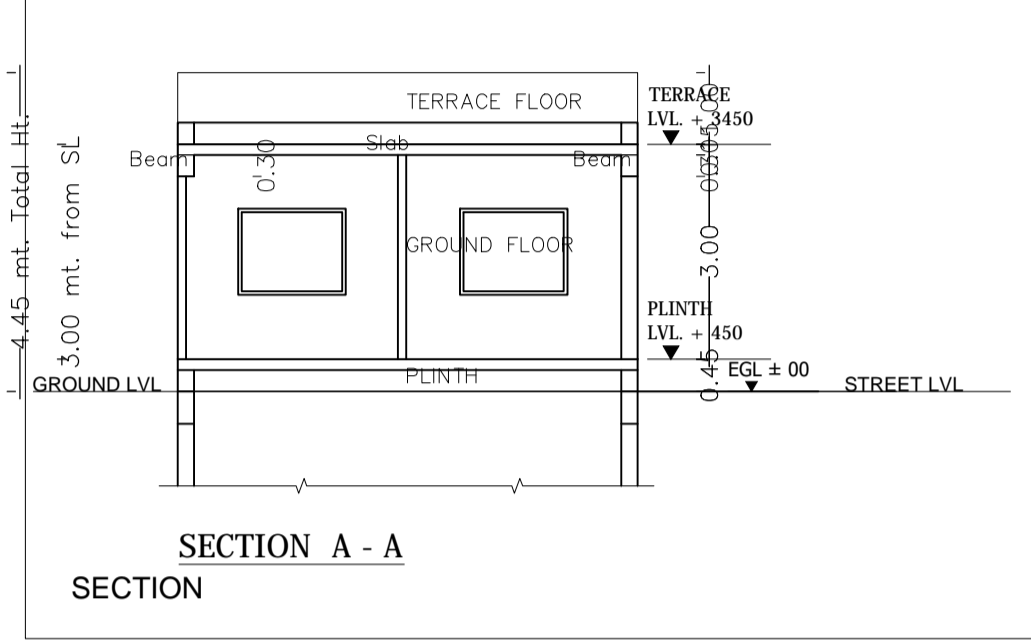
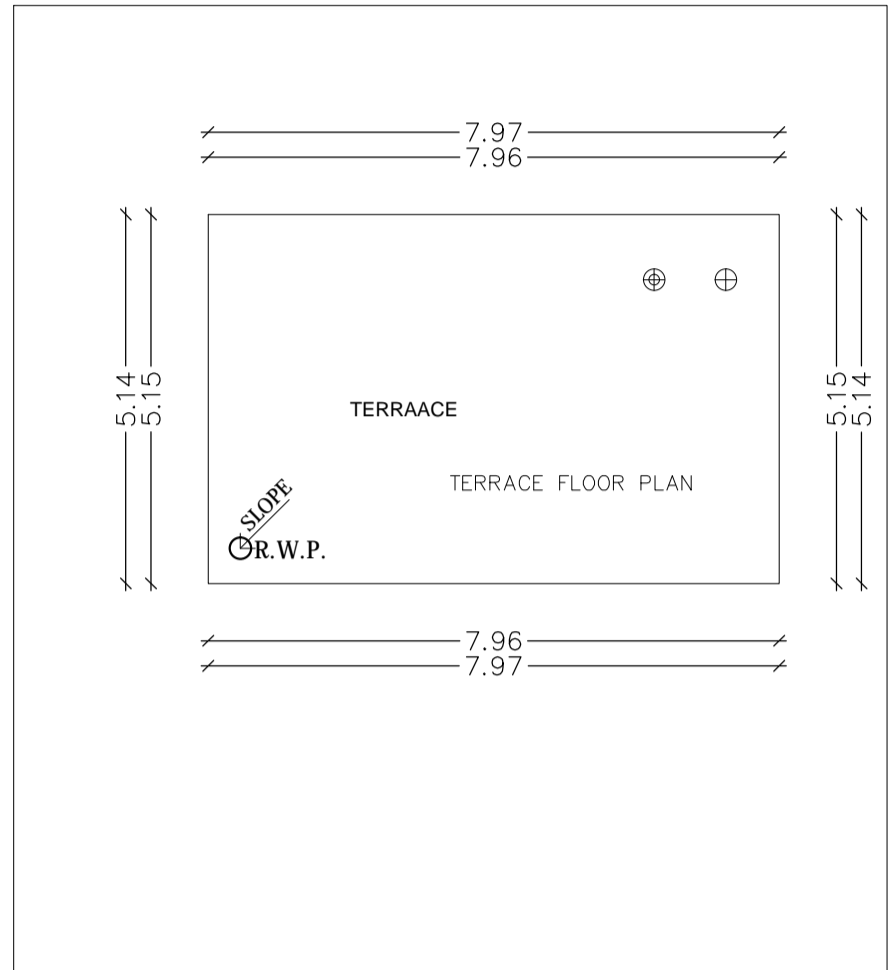
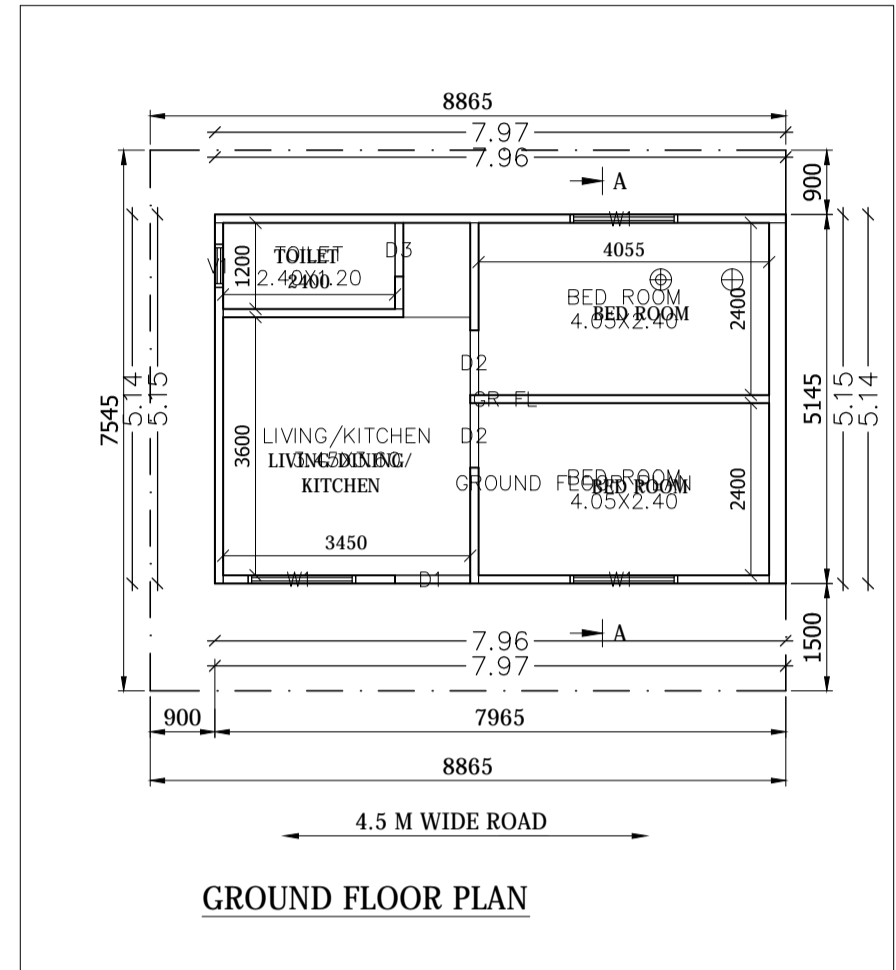

A (ANAND PANDEY)

Building : A (ANAND PANDEY)

Floor Name	Total Built Up Area (Sq.mt.)	Proposed FAR Area (Sq.mt.) Resi.	Total FAR Area (Sq.mt.)	Tnmt (No.)
Ground Floor...	40.98	40.98	40.98	01
Terrace Floor...	0.00	0.00	0.00	00
Total :	40.98	40.98	40.98	01
Total Number of Same Buildings :	1			
Total :	40.98	40.98	40.98	01

SCHEDULE OF JOINERY:

BUILDING NAME	NAME	LENGTH	HEIGHT	NOS
A (ANAND PANDEY)	D3	0.75	2.10	01
A (ANAND PANDEY)	D2	0.90	2.10	02
A (ANAND PANDEY)	D1	1.05	2.10	01
Total	-	-	-	04

SCHEDULE OF JOINERY:

BUILDING NAME	NAME	LENGTH	HEIGHT	NOS
A (ANAND PANDEY)	v1	0.60	1.00	01
A (ANAND PANDEY)	w1	1.50	1.20	03
Total	-	-	-	04

UnitBUA Table for Building : A (ANAND PANDEY)

FLOOR	Name	UnitBUA Type	UnitBUA Area	Carpet Area	No. of Rooms	No. of Tenement
GROUND FLOOR PLAN	GR FL	FLAT	40.98	36.41	4	1
Total	-	-	40.98	36.41	4	1

AREA STATEMENT: MANGO MUNICIPAL CORPORATION	VERSION NO.: 1.0.28
PROJECT DETAIL :	VERSION DATE: 16/10/2020
Inward No. : -	Plot Use : Residential
Region : JHARKHAND URBAN LOCAL BODIES	Plot SubUse : Row House
District : EAST SINGHBHUM	Land Use Zone : Residential
Application Type : General Proposal	Abutting Road Width : 4.5
Project Type : Building Permission	Plot No. : -
Nature of Development : New	Revenue Survey No./Survey No : -
Location : Old Area	Thana No : -
Sub Location : NA	Holding No : -
Village/Mauza Name : -	Khata No : -
Ward No : -	North : -
Road/Street : -	South : -
	East : -
	West : -

AREA DETAILS :		SQ.MT.
AREA OF PLOT (Minimum)	(A)	66.89
Net Plot Area (Gross Plot Area - Deduction from Gross Plot area)	(A-Deductions)	66.89
Balance Plot Area (Net Plot Area - Recreational/Amenity space)	(A-Deductions)	66.89
Plot Area for Coverage (Net Plot Area)	(A-Deductions)	66.89
Plot Area for FSI (Net Plot Area + RoadWidening Area)	(A-Deductions)	66.89

COVERAGE CHECK	
Proposed Coverage Area (61.27 %)	40.98
Total Coverage Area (61.27 %)	40.98

FAR CHECK	
Proposed Area of FAR	40.98
Total Area of FAR	40.98

BUILT UP AREA CHECK	
Total Proposed BuiltUp Area	40.98

ARCH / ENGG / SUPERVISOR (Regd.)	OWNER
DEVELOPMENT AUTHORITY	LOCAL BODY

COLOR INDEX	
PLOT BOUNDARY	██████████
ABUTTING ROAD	██████████
PROPOSED WORK (COVERAGE AREA)	██████████
EXISTING (To be retained)	██████████
EXISTING (To be demolished)	██████████

Color Index:
MARGIN DETAIL:

Building / Wing Name	Road Name	Front Margin	Rear Margin	Side1 Margin	Side2 Margin
A-1 (ANAND PANDEY)	4.5 M WIDE ROAD	1.50	0.90	0.90	0.00

FAR & Tenement Details (Table 4c-1)

Building	No. of Same Bldg	Total Built Up Area (Sq.mt.)	Proposed FAR Area (Sq.mt.) Resi.	Total FAR Area (Sq.mt.)	Tnmt (No.)
A (ANAND PANDEY)	1	40.98	40.98	40.98	01
Grand Total :	1	40.98	40.98	40.98	01