

Buildingwise Floor FAR Details

Floor Name	Building Name A (ASAM KHATOON)		Total	
	Proposed Built Up Area (Sq.mt.)	Proposed FAR Area (Sq.mt.)	Total Proposed Built Up Area (Sq.mt.)	Total FAR Area (Sq.mt.)
Ground Floor	110.36	15.45	110.36	15.45
First Floor	128.21	128.21	128.21	128.21
Second Floor	128.21	128.21	128.21	128.21
Third Floor	128.21	128.21	128.21	128.21
Terrace Floor	0.00	0.00	0.00	0.00
Total :	494.99	400.08	494.99	400.08

FAR & Tenement Details (Table 4c-1)

Building	No. of Same Bldg	Total Built Up Area (Sq.mt.)	Deductions (Area in Sq.mt.)		Proposed FAR Area (Sq.mt.)	Add Area in FAR (Sq.mt.)	Total FAR Area (Sq.mt.)	Total Consumed Additional FAR Area (Sq.mt.)	Tnmt (No.)
			Parking	Resi.					
A (ASAM KHATOON)	1	494.99	94.91	384.63	15.45	400.08	400.08	03	
Grand Total :	1	494.99	94.91	384.63	15.45	400.08	400.08	03	

Proposal Basic Information

Proposal File No.	MNAC/BP/0035/W08/2021
Owner Name	ASMA KHATOON W/O LATE HAYAT MOHAMMAD ANSARI
Khata No	788
Plot No	2629
Village Name	Mango
Use	Residential
SubUse	Bungalow/ Dwelling / Non Apartment

AREA STATEMENT MANGO MUNICIPAL CORPORATION	VERSION NO.: 1.0.60
	VERSION DATE: 16/10/2020
PROJECT DETAIL:	
Region: JHARKHAND URBAN LOCAL BODIES	Plot Use: Residential
District: EAST SINGHBHUM	Plot SubUse: Bungalow/ Dwelling / Non Apartment
Authority: MANGO MUNICIPAL CORPORATION	PlotNearbyReligiousStructure: NA
Inward_No: MNAC/BP/0035/W08/2021	Plot/SubPlot No: 2629
Application Type: General Proposal	North: -
Project Type: Building Permission	South: -
Nature of Development: New	East: -
Location of Development Area: Old Area	West: -
AREA DETAILS:	
AREA OF PLOT (Minimum)	(A) 189.74
NET AREA OF PLOT (Gross Plot Area - Deduction from Gross Plot area)	(A-Deductions) 189.74
Deduction for Balance Plot Area (from Gross Plot Area)	
Common Plot Total	12.97
BALANCE AREA OF PLOT (Net Plot Area - Recreational/Amenity space)	(A-Deductions) 176.77
PLOT AREA FOR COVERAGE (Net Plot Area)	(A-Deductions) 189.74
Plot Area for FAR (Net Plot Area + Road Widening Area)	(A-Deductions) 189.74
COVERAGE CHECK	
Permissible Coverage area (60.00 %)	113.84
Proposed Coverage Area (58.16 %)	110.36
Total Prop. Coverage Area (58.16 %)	110.36
Balance coverage area (1.83 %)	3.48
FAR CHECK	
Perm. FAR Area (2.50)	474.35
Total Perm. FAR area	474.35
Residential FAR	384.62
Proposed FAR Area	400.07
Total Proposed FAR Area	400.07
Consumed FAR (Factor)	2.11
Balance FAR Area	74.28
BUILT UP AREA CHECK	
Total Proposed BuiltUp Area	494.99
ARCHITECT (Regd)	MOHAMMAD BELAL NASIR
ENGINEER (Regd)	
SUPERVISOR (Regd)	
OWNER (Regd)	ASMA KHATOON W/O LATE HAYAT MOHAMMAD ANSARI
DEVELOPMENT AUTHORITY	LOCAL BODY

Required Parking (Table 7a)

Building Name	Type	SubUse	Area (Sq.mt.)	Units		Car		Visitors Car		TwoWheeler	
				Reqd.	Prop.	Reqd./Unit	Reqd.	Prop.	Reqd./Unit	Reqd.	Prop.
A (ASAM KHATOON)	Residential	Bungalow/ Dwelling / Non Apartment	> 0	1	3.00	1.00	3	-	-	-	-
			> 0	1	3.00	-	-	1	1	-	-
Total :							3	2	-	1	1

Parking Check (Table 7b)

Vehicle Type	Reqd.		Prop.	
	No.	Area	No.	Area
Car	-	-	2	40.14
Total Car	3	37.50	2	40.14
Visitor's Car Parking	-	-	1	15.14
Total Visitor Parking	1	12.50	1	15.14
TwoWheeler	-	-	3	13.56
Total TwoWheeler	-	-	3	13.56
Other Parking	-	-	-	26.07
Total		50.00		108.47

Building USE/SUBUSE Details

Building Name	Building Use	Building SubUse	Building Structure
A (ASAM KHATOON)	Residential	Bungalow/ Dwelling / Non Apartment	Non-Highrise

COLOR INDEX

PLOT BOUNDARY	Black
ABUTTING ROAD	Green
PROPOSED CONSTRUCTION	Red
COMMON PLOT	Yellow
ROAD WIDENING AREA	Orange
EXISTING (To be retained)	Blue
EXISTING (To be demolished)	Light Blue

LTP NAME AND SIGNATURE	STRUCTURAL ENG'S NAME AND SIGNATURE	SUBVENDOR NAME AND SIGNATURE	REAL SIGNATURE
MOHAMMAD BELAL NASIR MNAC/ENG/0007/2016			

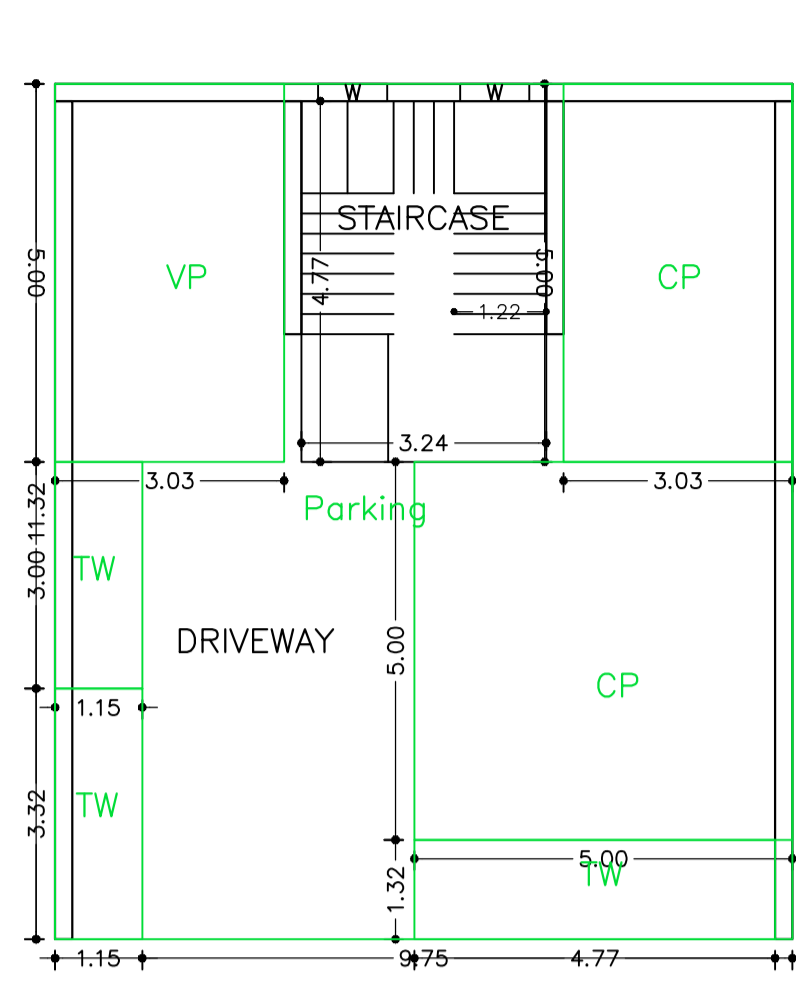

GROUND FLOOR PLAN (SCALE 1:100)

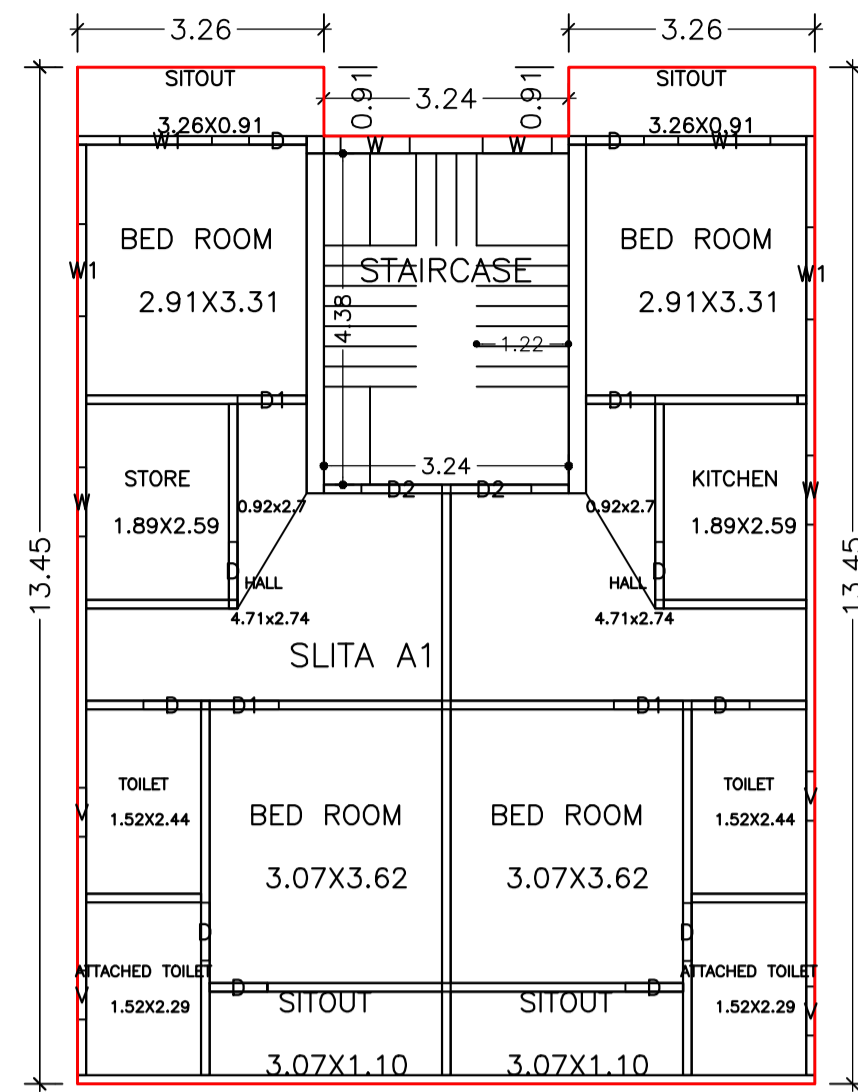

FIRST FLOOR PLAN (Proposed) (SCALE 1:100)

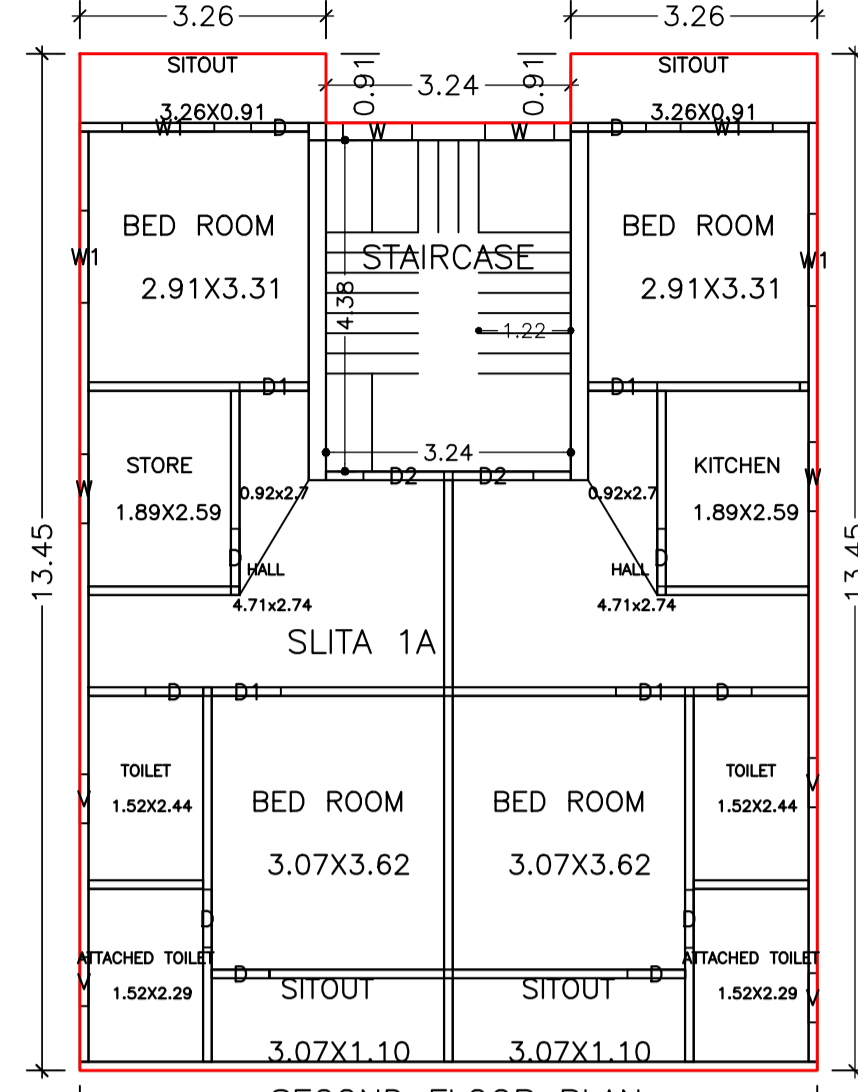

SECOND FLOOR PLAN (Proposed) (SCALE 1:100)

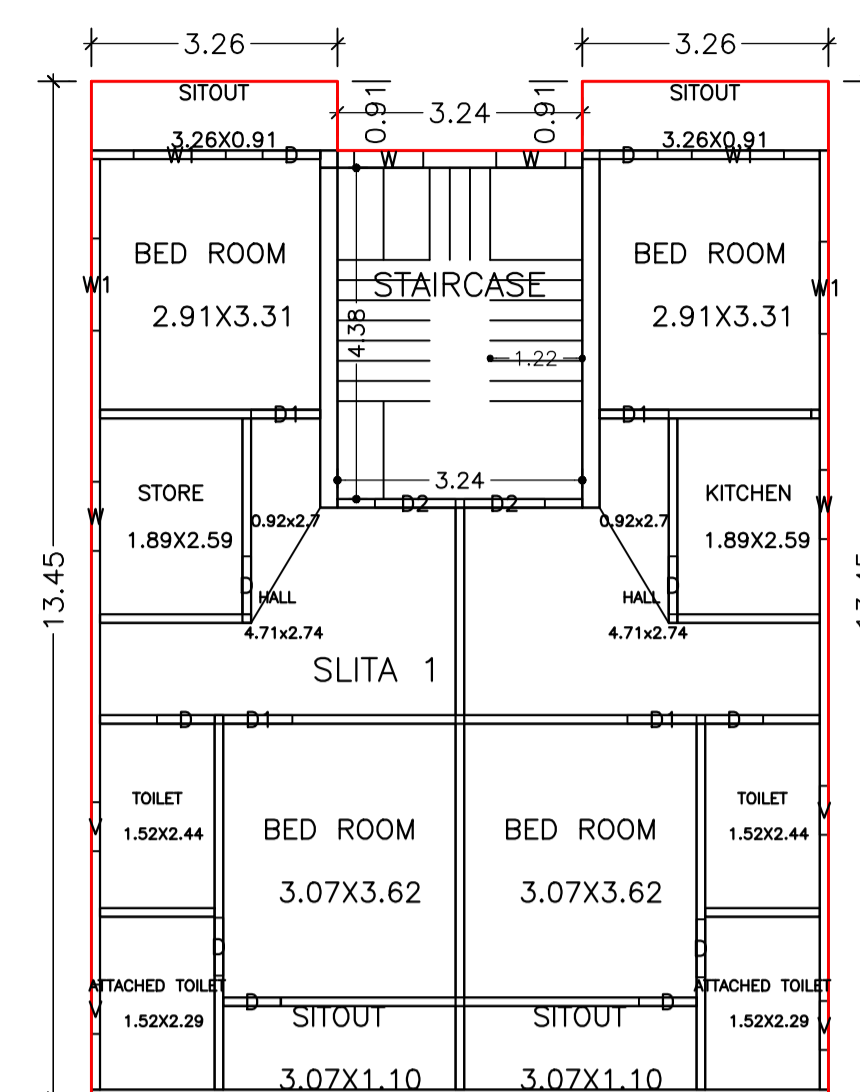

THIRD FLOOR PLAN (Proposed) (SCALE 1:100)

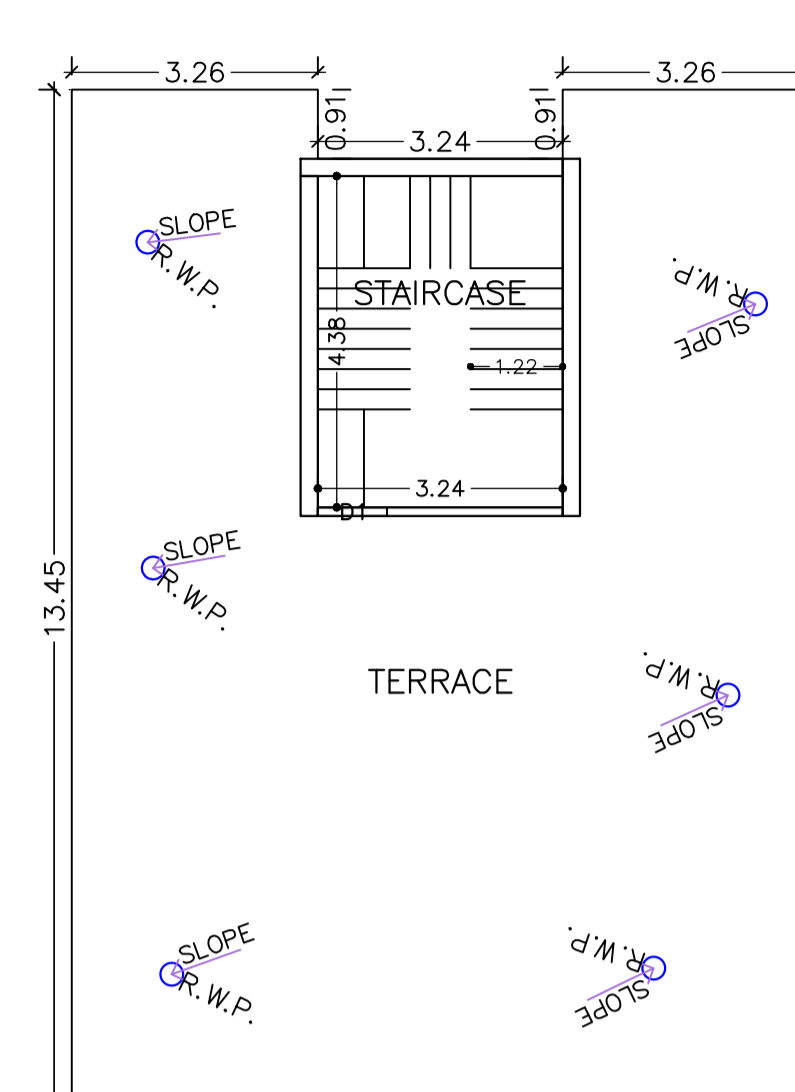

TERRACE FLOOR PLAN (SCALE 1:100)

Proposal Basic Information	
Proposal File No	MNAC/BP/0035/W08/2021
Owner Name	ASMA KHATOON W/O LATE HAYAT MOHAMMAD ANSARI
Khata No	788
Plot No	2629
Village Name	Mango
Use	Residential
SubUse	Bungalow/ Dwelling / Non Apartment

Building :A (ASAM KHATOON)

Floor Name	Total Built Up Area (Sq.mt.)	Deductions (Area in Sq.mt.)	Proposed FAR Area (Sq.mt.)	Add Area In FAR (Sq.mt.)	Total FAR Area (Sq.mt.)	Total Consumed Additional FAR Area (Sq.mt.)	Tnmt (No.)
Ground Floor	110.36	94.91	0.00	15.45	15.45	15.45	00
First Floor	128.21	0.00	128.21	0.00	128.21	128.21	01
Second Floor	128.21	0.00	128.21	0.00	128.21	128.21	01
Third Floor	128.21	0.00	128.21	0.00	128.21	128.21	01
Terrace Floor	0.00	0.00	0.00	0.00	0.00	0.00	00
Total :	494.99	94.91	384.63	15.45	400.08	400.08	03
Total Number of Same Buildings :	1						
Total :	494.99	94.91	384.63	15.45	400.08	400.08	03

SCHEDULE OF DOOR:

BUILDING NAME	NAME	LENGTH	HEIGHT	NOS
A (ASAM KHATOON)	D	0.77	2.10	30
A (ASAM KHATOON)	D1	0.91	2.10	12
A (ASAM KHATOON)	D2	1.07	2.10	06

SCHEDULE OF WINDOW/VENTILATION:

BUILDING NAME	NAME	LENGTH	HEIGHT	NOS
A (ASAM KHATOON)	V	0.65	0.11	12
A (ASAM KHATOON)	W	0.91	1.20	14
A (ASAM KHATOON)	W1	1.22	1.20	12

UnitBUA Table for Building :A (ASAM KHATOON)

FLOOR	Name	UnitBUA Type	UnitBUA Area	Carpet Area	No. of Rooms	No. of Tenement
FIRST FLOOR PLAN	SLITA A1	FLAT	128.21	114.44	16	1
SECOND FLOOR PLAN	SLITA 1A	FLAT	128.21	114.44	16	1
THIRD FLOOR PLAN	SLITA 1	FLAT	128.21	114.44	16	1
Total:	-	-	384.63	343.32	48	3

LTP NAME AND SIGNATURE	STRUCTURAL ENG'S NAME AND SIGNATURE	SIENALDERNAME AND SIGNATURE	REAL SIGNATURE
MOHAMMAD BELAL NASIR MNAC/ENG/0007/2016			

Proposal Basic Information	
Proposal File No	MNAC/BP/0035/W08/2021
Owner Name	ASMA KHATOON W/O LATE HAYAT MOHAMMAD ANSARI
Khata No	788
Plot No	2629
Village Name	Mango
Use	Residential
SubUse	Bungalow/ Dwelling / Non Apartment

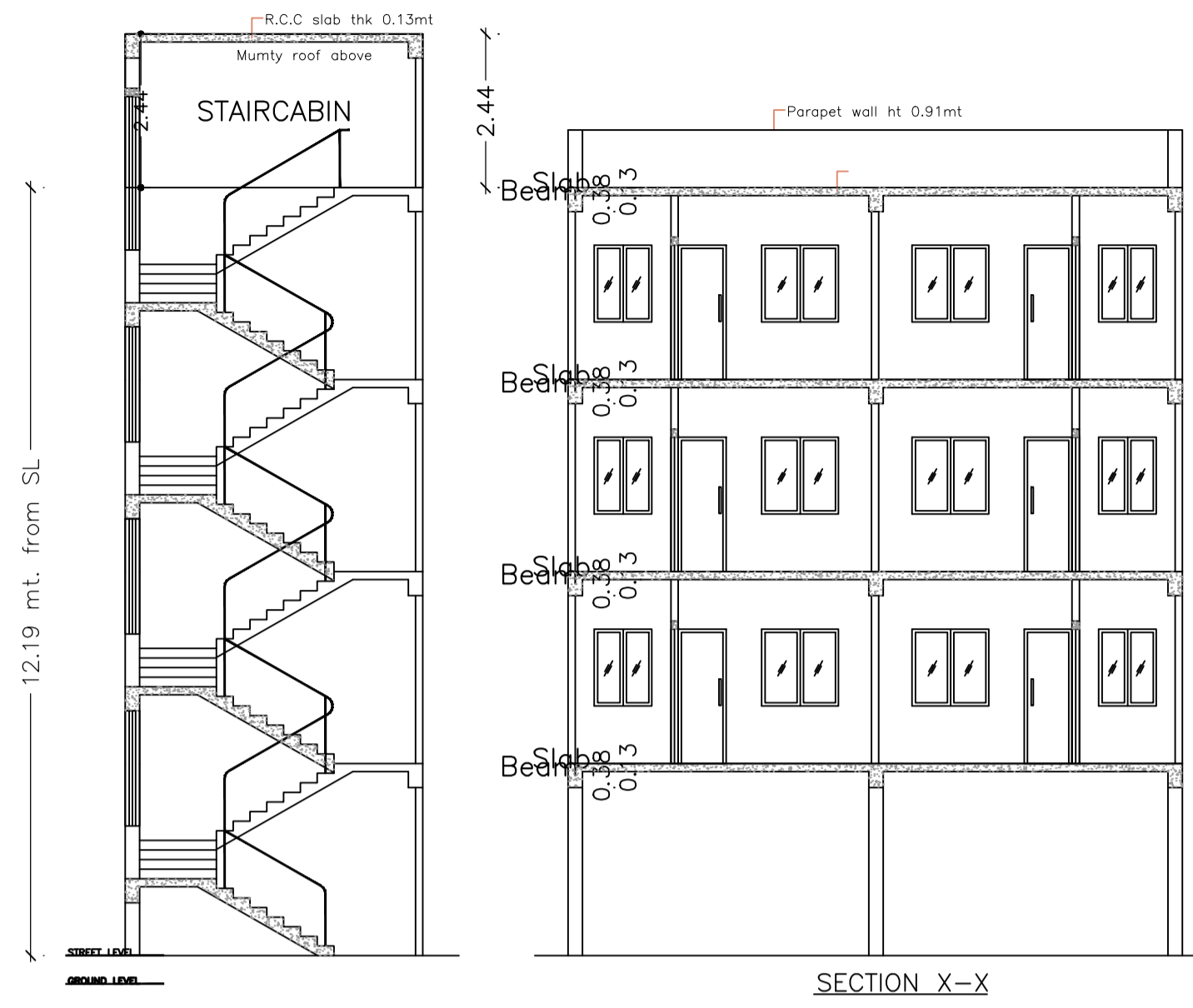

SECTION X-X

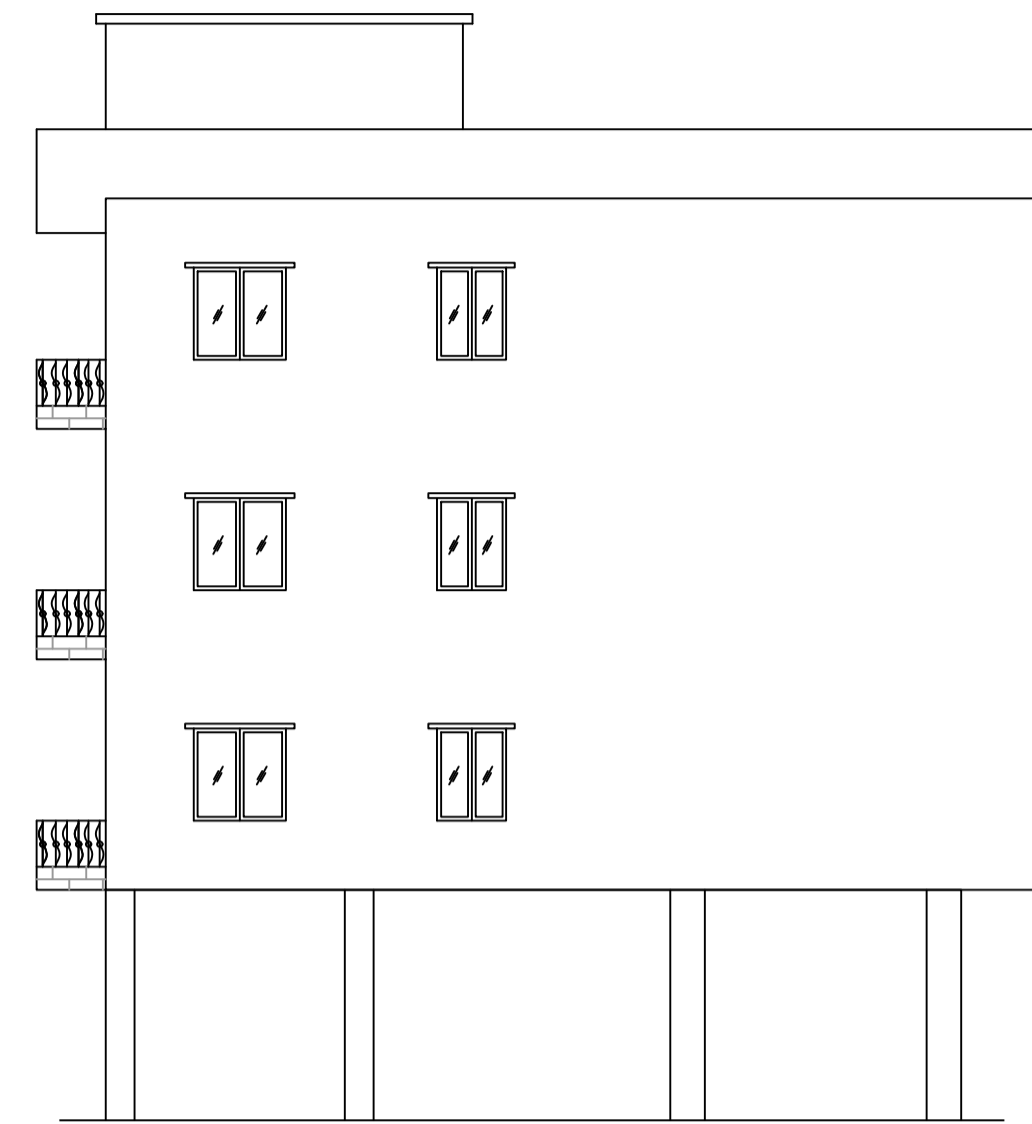

SIDE ELEVATION

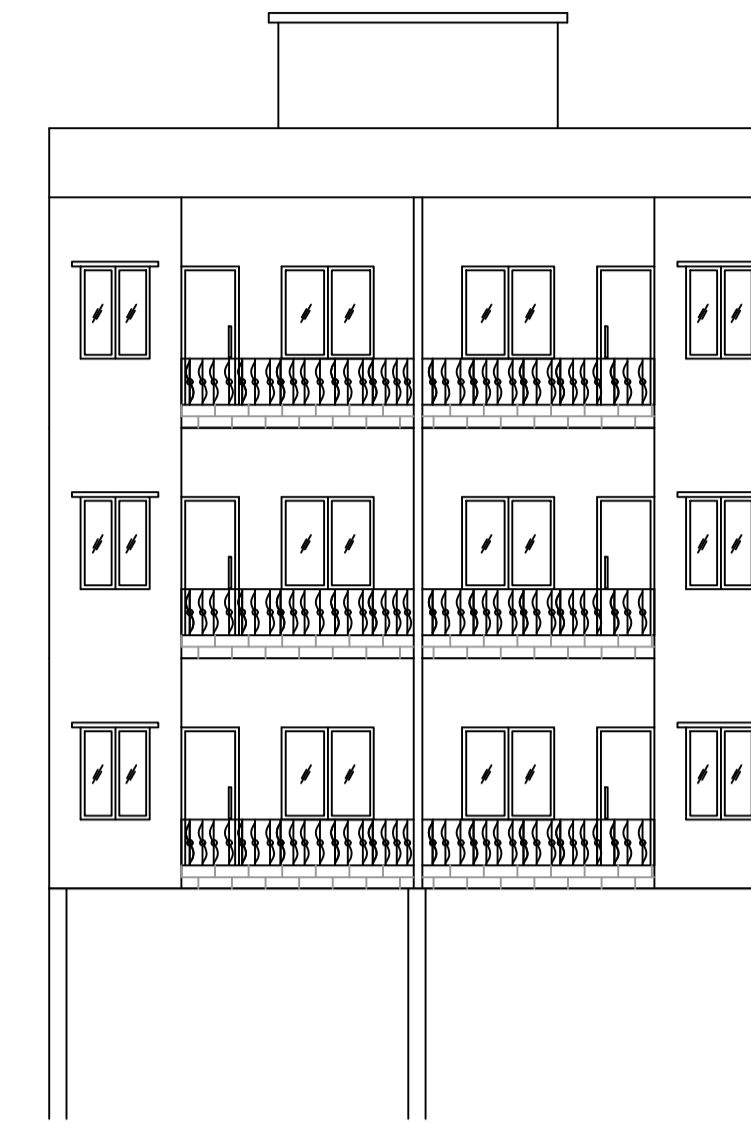

FRONT ELEVATION

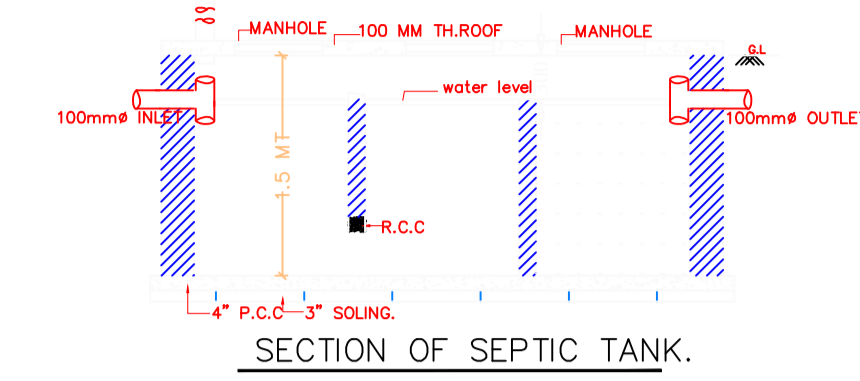

SECTION OF SEPTIC TANK.

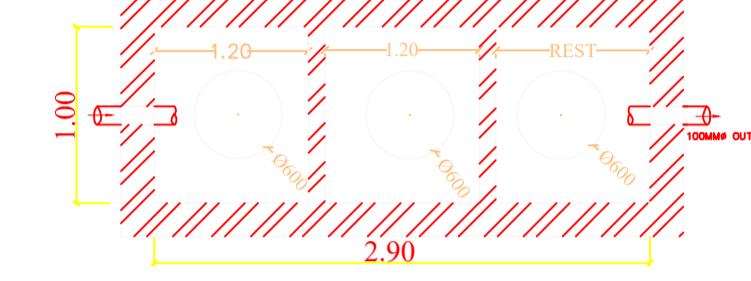

PLAN OF SEPTIC TANK

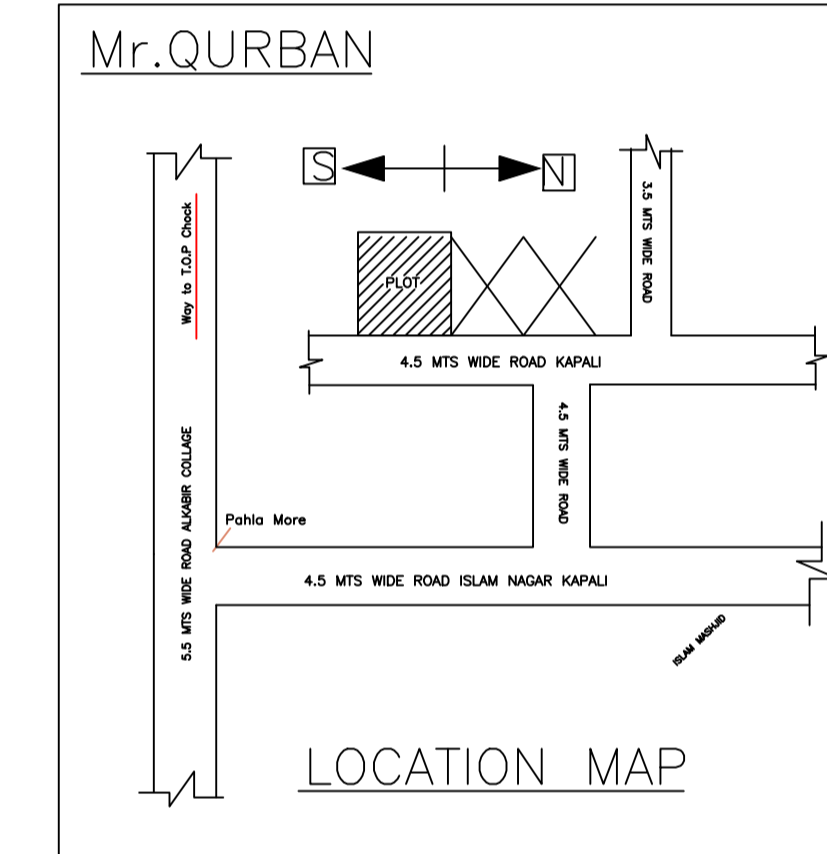

LOCATION MAP

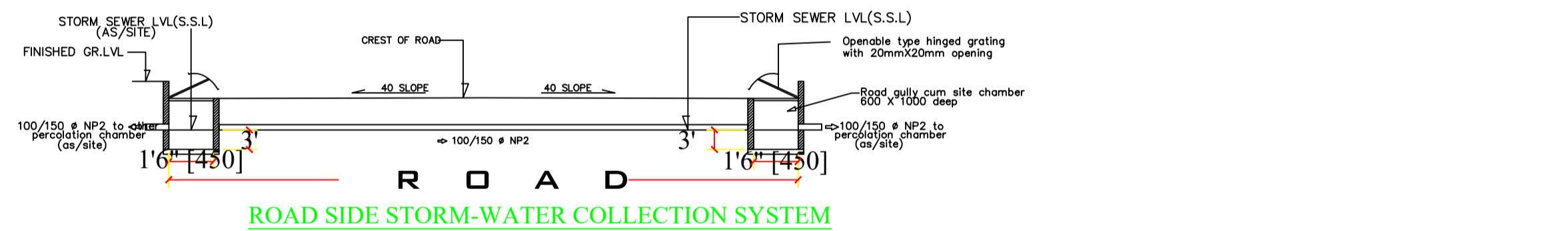

ROAD SIDE STORM-WATER COLLECTION SYSTEM

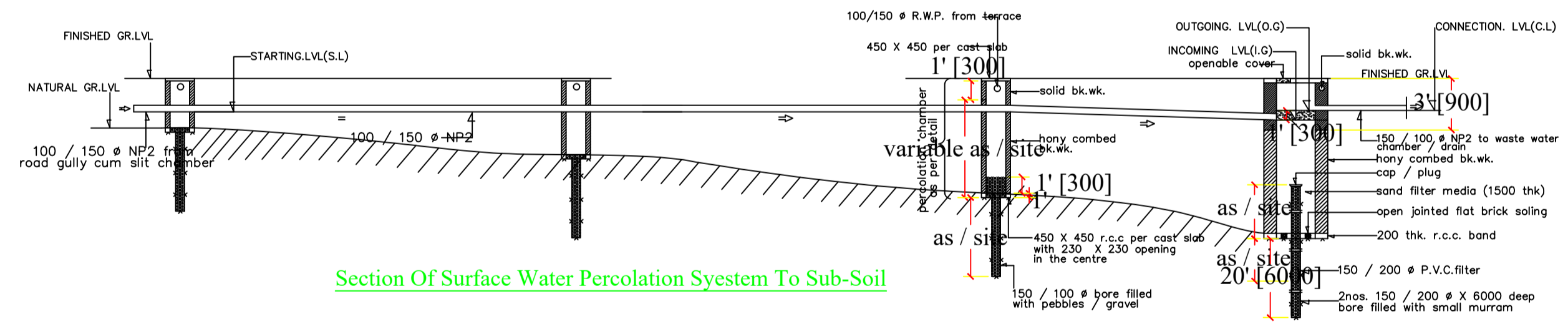

Section Of Surface Water Percolation System To Sub-Soil

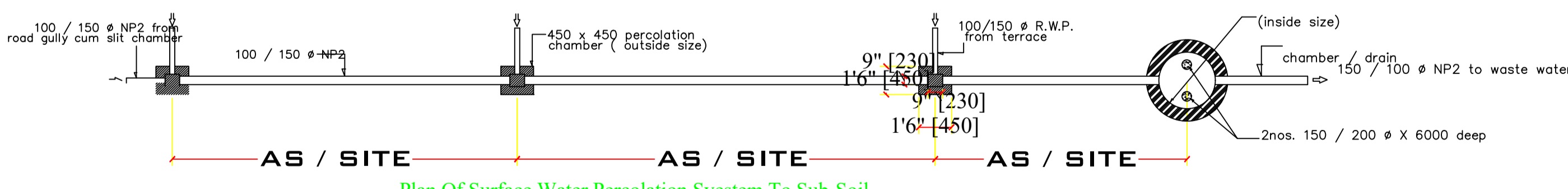

Plan Of Surface Water Percolation System To Sub-Soil

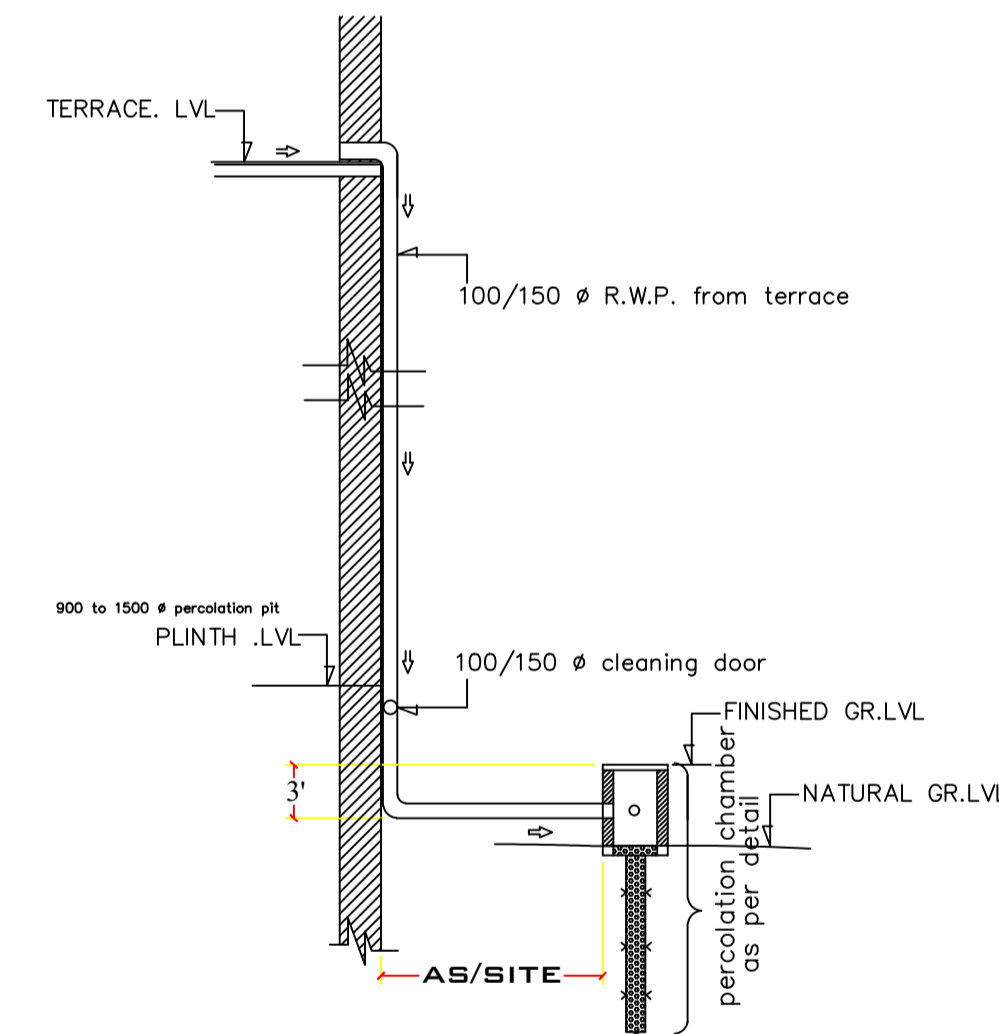

Roof Top Rain Water Collection System

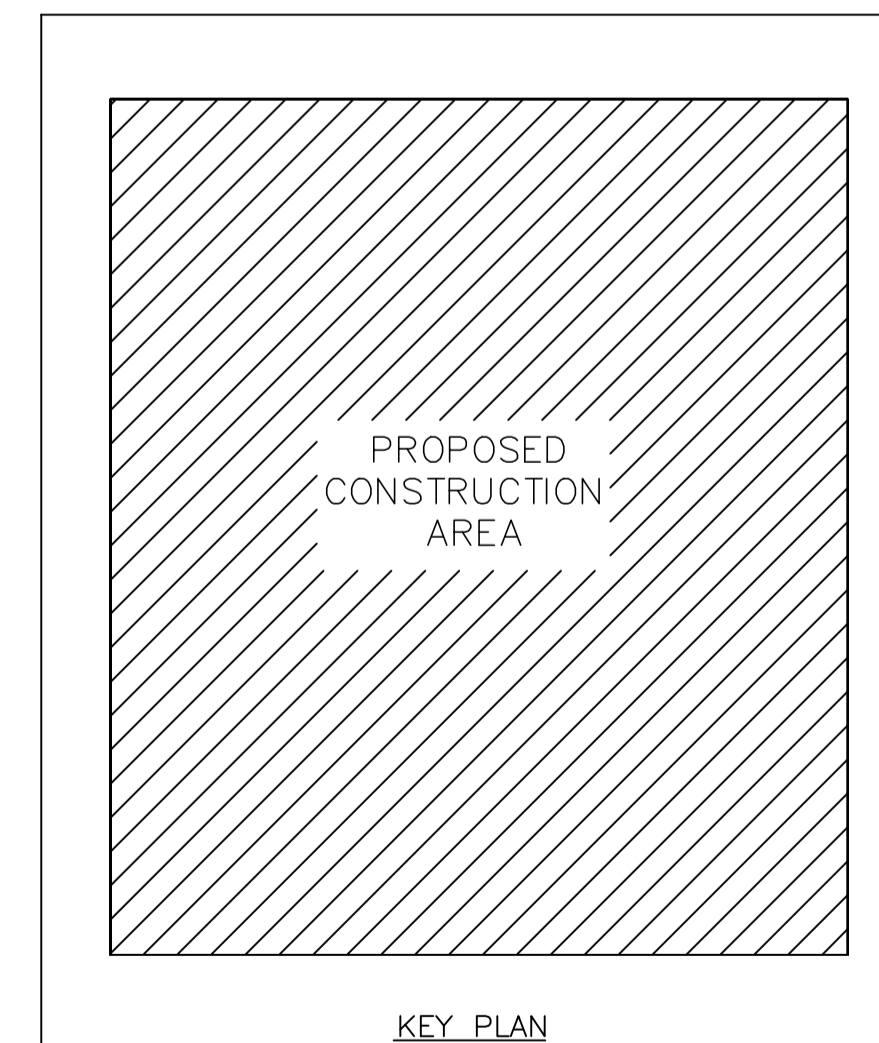

KEY PLAN

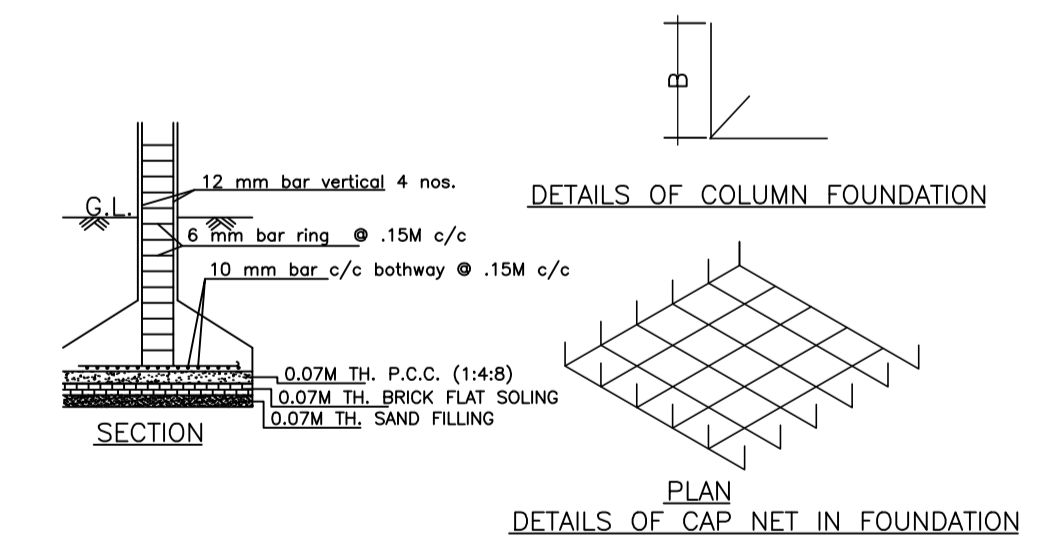

SECTION

PLAN

LTP NAME AND SIGNATURE	STRUCTURAL ENG'S NAME AND SIGNATURE	SEAL AND SIGNATURE	AUTOREAL SIGNATURE
MOHAMMAD BELAL NASIR MNAC/ENG/0007/2016			