

SITE PLAN

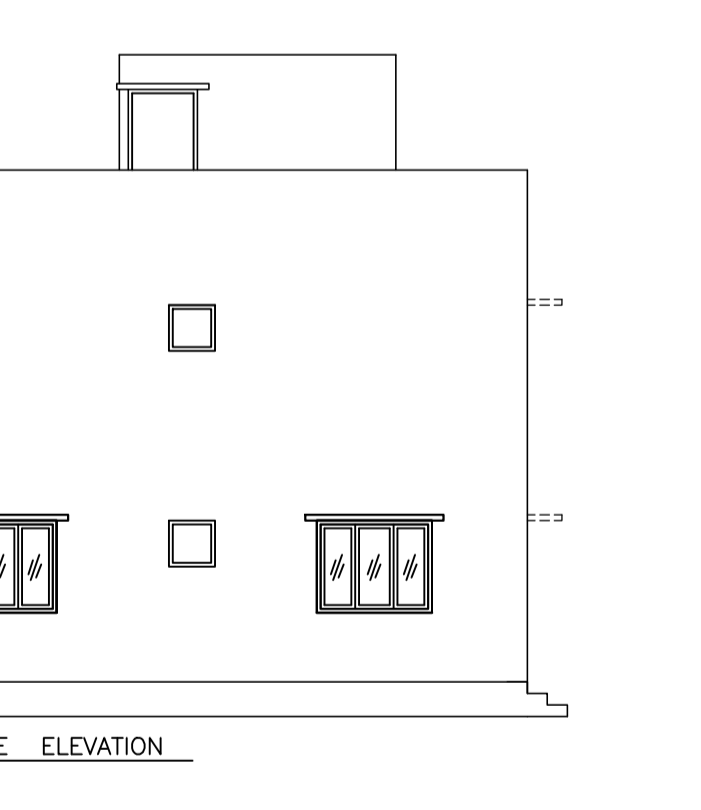
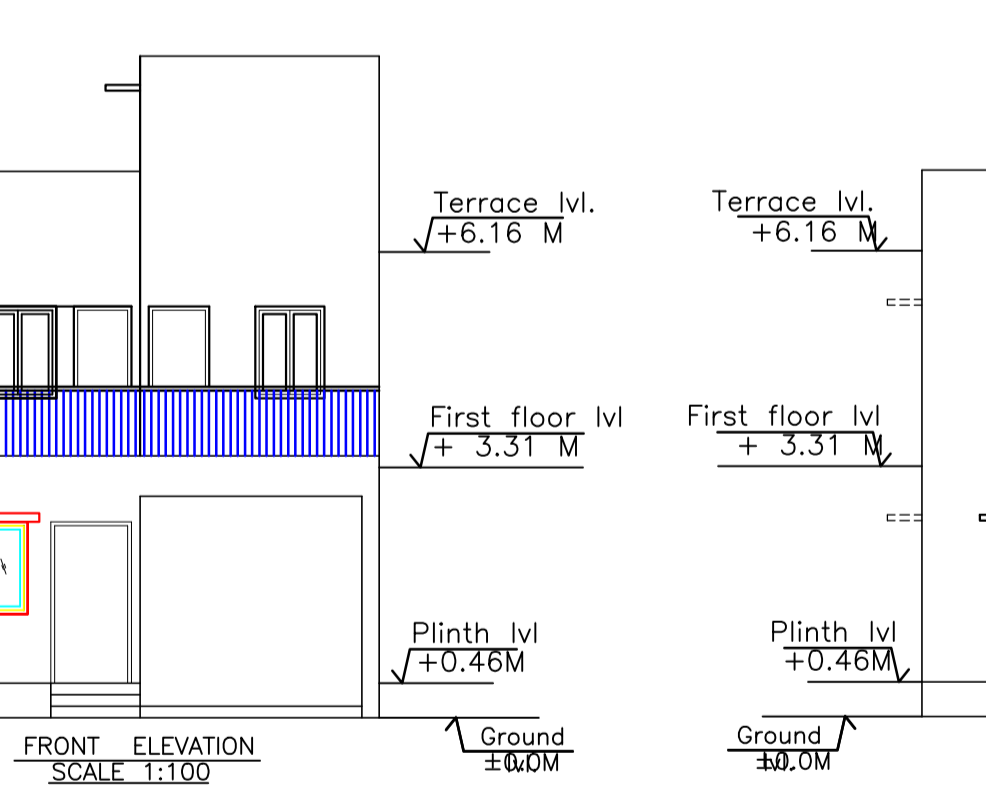
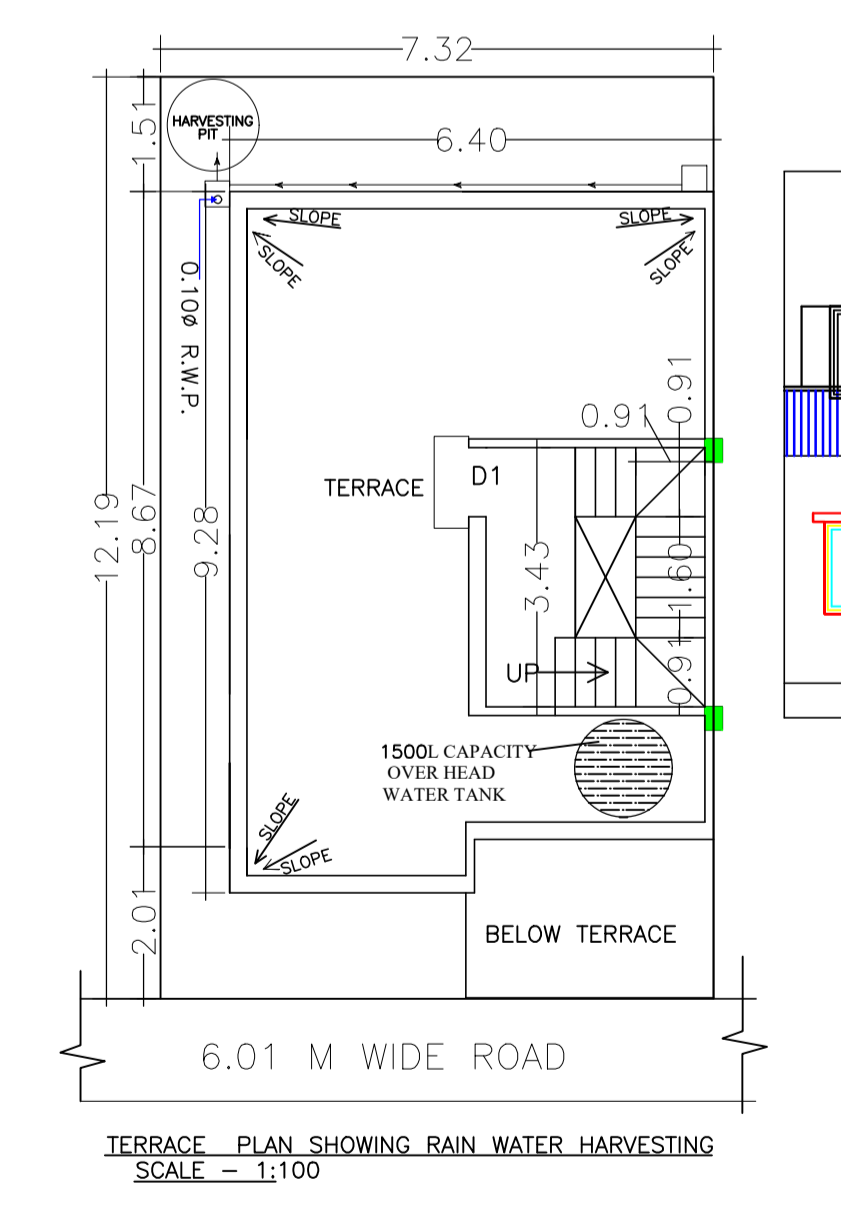
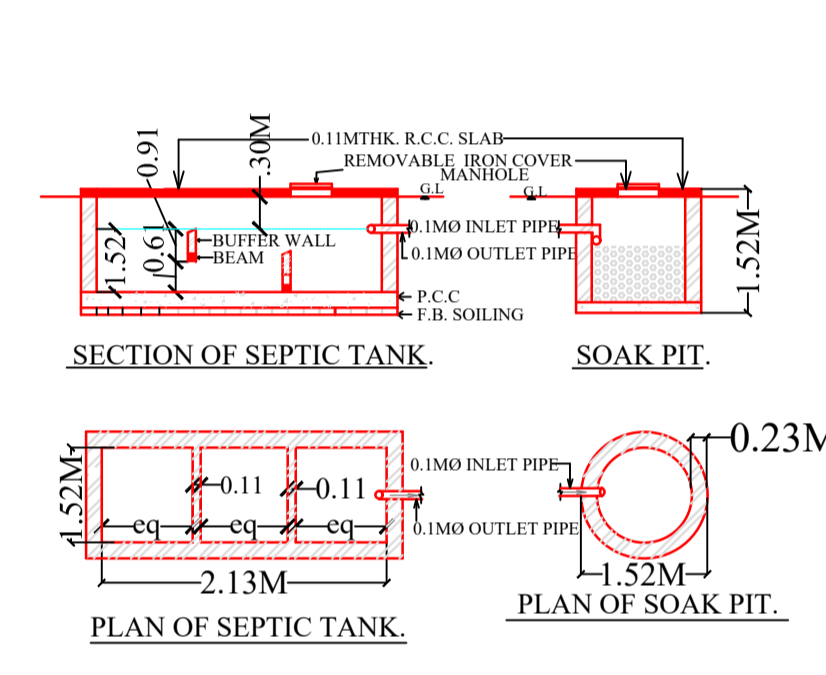
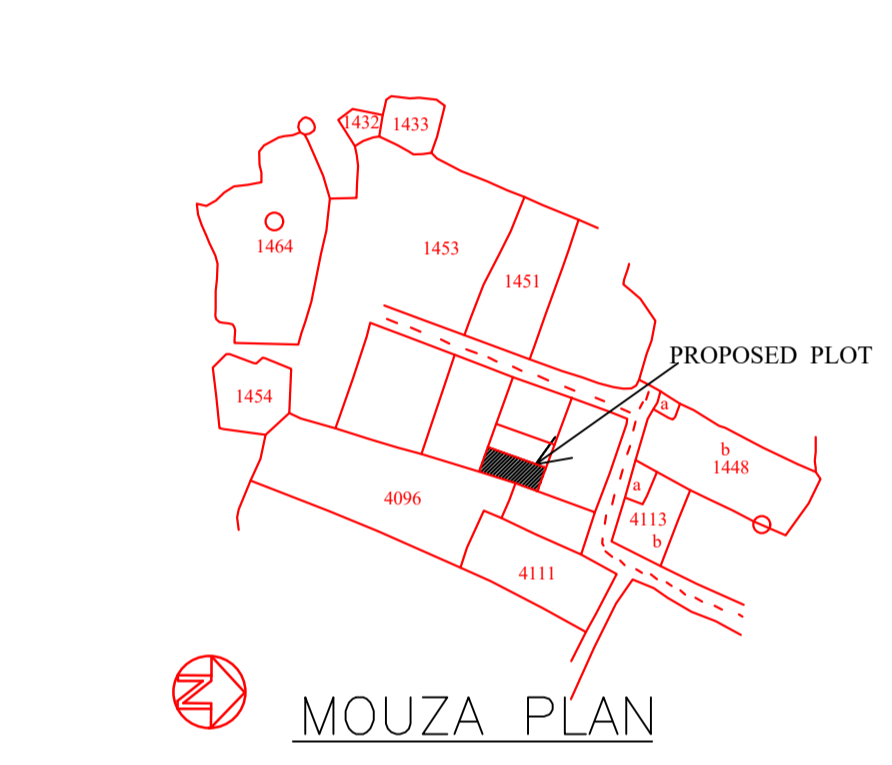
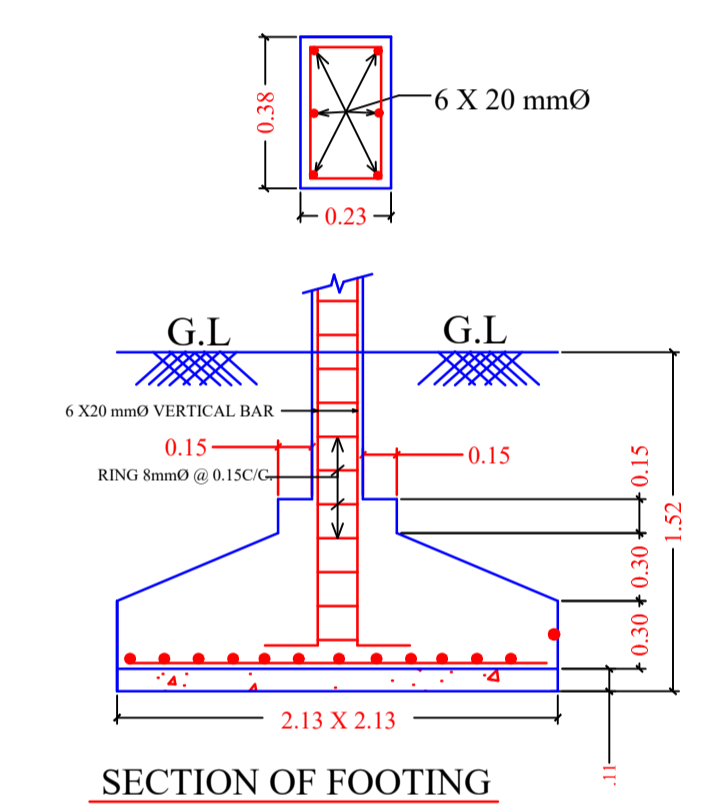
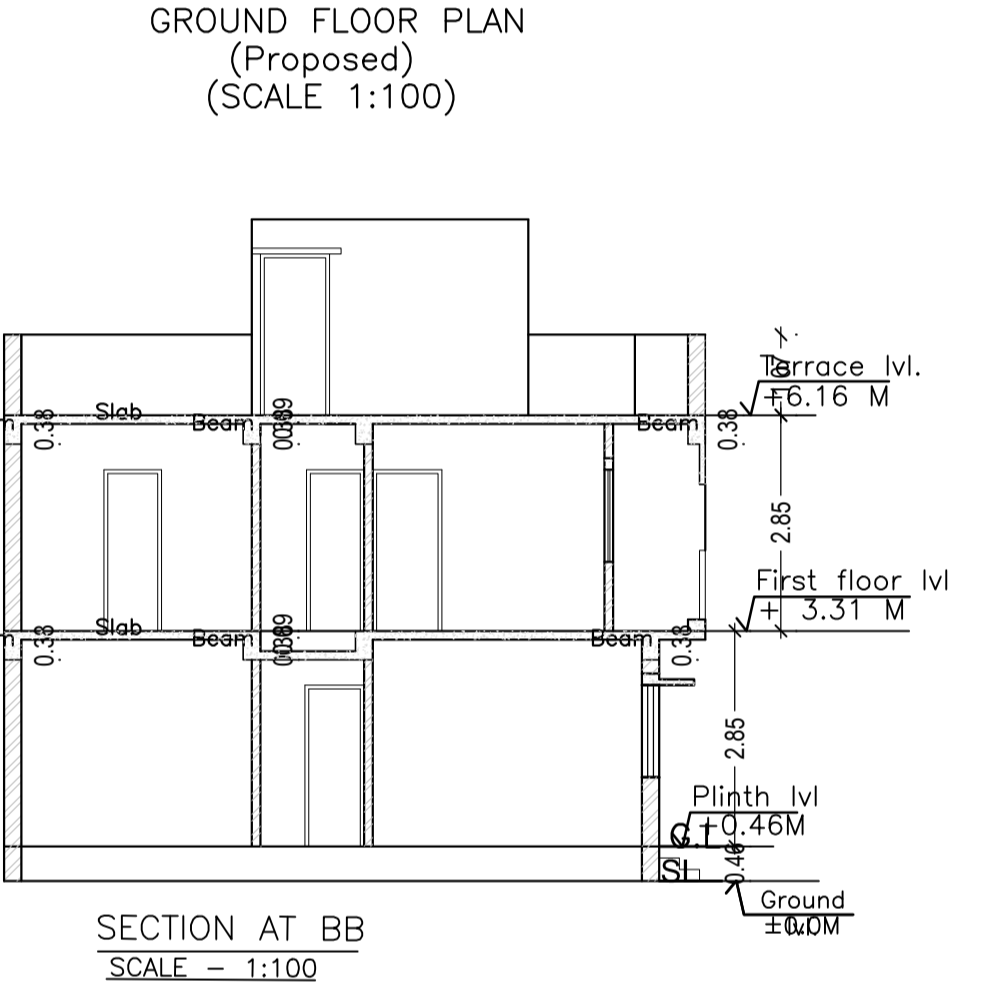
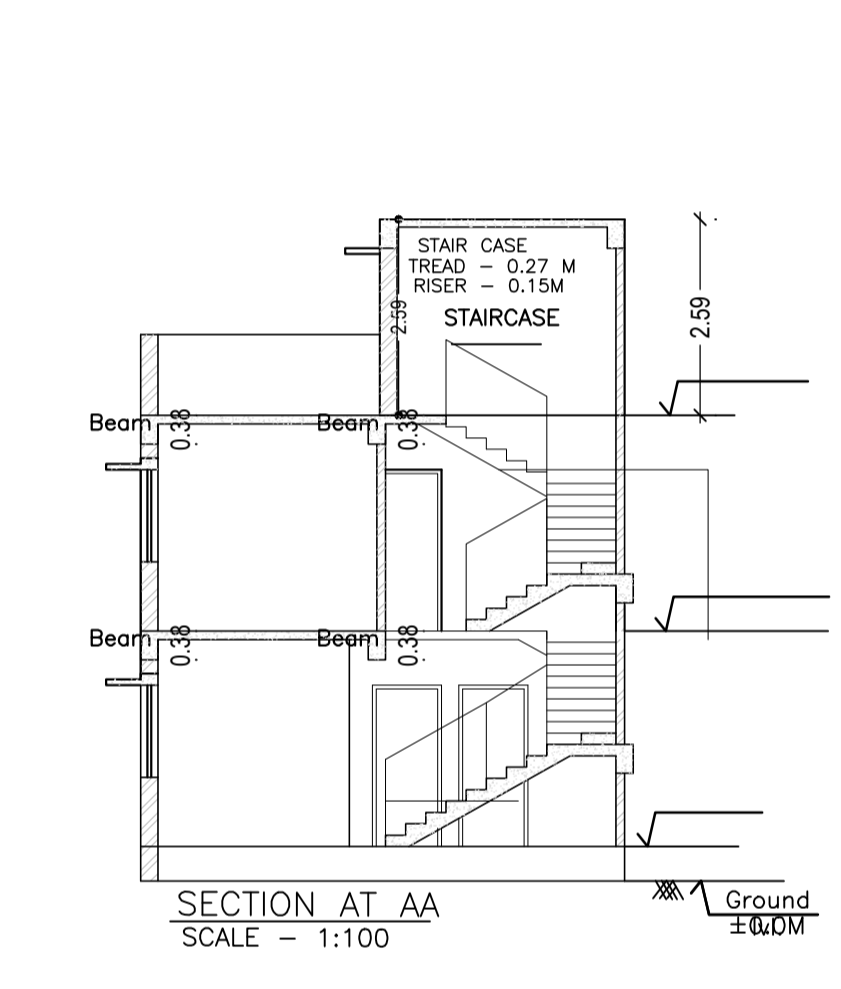

COLOR INDEX

PLOT BOUNDARY	Black
ABUTTING ROAD	Red
PROPOSED CONSTRUCTION	Green
COMMON PLOT	Yellow
ROAD WIDENING AREA	Blue
EXISTING (To be retained)	Light Blue
EXISTING (To be demolished)	Dark Blue

FAR & Tenement Details (Table 4c-1)

Building	No. of Same Bldg	Total Built Up Area (Sq.mt.)	Proposed FAR Area (Sq.mt.)	Total FAR Area (Sq.mt.)	Total Consumed Additional FAR Area (Sq.mt.)	Tnmt (No.)
A (BUILDING)	1	95.20	95.20	95.20	95.20	01
Grand Total :	1	95.20	95.20	95.20	95.20	01

UnitBUA Table for Building :A (BUILDING)

FLOOR	Name	UnitBUA Type	UnitBUA Area	Carpert Area	No. of Rooms	No. of Tenement
GROUND FLOOR PLAN	SPLIT HOUSE-1	FLAT	95.20	83.13	4	1
FIRST FLOOR PLAN	SPLIT HOUSE-1	FLAT	0.00	0.00	4	0
Total:	-	-	95.20	83.13	8	1

Proposal Basic Information

Proposal File No.	MNAC/BP/0010/W10/2021
Owner Name	ABHAY KUMAR
Khata No	425
Plot No	1453 (PART)
Village Name	Baliguma
Use	Residential
SubUse	Other Residential Building

AREA STATEMENT MANGO MUNICIPAL CORPORATION

VERSION NO.: 1.0.54
VERSION DATE: 16/10/2020

PROJECT DETAIL:
Region: JHARKHAND URBAN LOCAL BODIES
District: EAST SINGHBHUM
Authority: MANGO MUNICIPAL CORPORATION
Inward No: MNAC/BP/0010/W10/2021
Application Type: General Proposal
Project Type: Building Permission
Nature of Development: New
Location of Development Area: Old Area

Plot Use: Residential
Plot SubUse: Other Residential Building
PlotNearby/Religious/Structure: NA
Plot/SubPlot No: 1453 (PART)
North: Plot No. - SUB. PLOT NO. - 7
South: Plot No. - SUB. PLOT NO. - 4096
East: Road Width - 6.1
West: Plot No. - SUB. PLOT NO. - 15

AREA DETAILS:

AREA OF PLOT (Minimum)	(A)	SQ.MT.
NET AREA OF PLOT(Gross Plot Area)	(A-Deductions)	89.19
Deduction from Gross Plot area	(A-Deductions)	89.19
Deduction for Balance Plot Area(from Gross Plot Area)		
Common Plot		10.11
Total		10.11
BALANCE AREA OF PLOT(Net Plot Area - Recreational/Amenity space)	(A-Deductions)	79.07
PLOT AREA FOR COVERAGE(Net Plot Area)	(A-Deductions)	89.19
Plot Area for FAR (Net Plot Area + RoadWidening Area)	(A-Deductions)	89.19
COVERAGE CHECK		
Permissible Coverage area (70.00 %)		62.43
Proposed Coverage Area (53.37 %)		47.60
Total Prop. Coverage Area (53.37 %)		47.60
Balance coverage area (16.63 %)		14.83
FAR CHECK		
Perm. FAR Area (2.50)		222.98
Total Perm. FAR area		222.98
Residential FAR		95.20
Proposed FAR Area		95.20
Total Proposed FAR Area		95.20
Consumed FAR (Factor)		1.07
Balance FAR Area		127.78
BUILT UP AREA CHECK		
Total Proposed BuiltUp Area		95.20
ARCHITECT (Regd)		SATISH KUMAR
ENGINEER (Regd)		
SUPERVISOR (Regd)		
OWNER (Regd)		ABHAY KUMAR
DEVELOPMENT AUTHORITY		LOCAL BODY

SCHEDULE OF DOOR:

BUILDING NAME	NAME	LENGTH	HEIGHT	NOS
A (BUILDING)	D2	0.76	2.13	03
A (BUILDING)	D1	0.91	2.13	04
A (BUILDING)	D	1.06	2.13	01

SCHEDULE OF WINDOW/VENTILATION:

BUILDING NAME	NAME	LENGTH	HEIGHT	NOS
A (BUILDING)	V	0.61	0.61	03
A (BUILDING)	w	0.91	1.22	01
A (BUILDING)	w	1.22	1.22	01
A (BUILDING)	w	1.52	1.22	06

Buildingwise Floor FAR Details

Floor Name	Building Name		Total	
	Proposed Built Up Area (Sq.mt.)	Proposed FAR Area (Sq.mt.)	Total Proposed Built Up Area (Sq.mt.)	Total FAR Area (Sq.mt.)
Ground Floor	47.60	47.60	47.60	47.60
First Floor	47.60	47.60	47.60	47.60
Terrace Floor	0.00	0.00	0.00	0.00
Total :	95.20	95.20	95.20	95.20

Building :A (BUILDING)

Floor Name	Total Built Up Area (Sq.mt.)	Proposed FAR Area (Sq.mt.)	Total FAR Area (Sq.mt.)	Total Consumed Additional FAR Area (Sq.mt.)	Tnmt (No.)
Ground Floor	47.60	47.60	47.60	47.60	01
First Floor	47.60	47.60	47.60	47.60	00
Terrace Floor	0.00	0.00	0.00	0.00	00
Total :	95.20	95.20	95.20	95.20	01
Total Number of Same Buildings :	1				
Total :	95.20	95.20	95.20	95.20	01

Building USE/SUBUSE Details

Building Name	Building Use	Building SubUse	Building Structure
A (BUILDING)	Residential	Residential Bldg/Apartment	Non-Highrise

LTP NAME AND SIGNATURE	STRUCTURAL ENG'S NAME AND SIGNATURE	BUILDER NAME AND SIGNATURE	DIGITAL SIGNATURE
SATISH KUMAR MNAC/DFTMN/0001/2017			