

Proposal Basic Information

Proposal File No.	MNAC/BP/0060/W10/2021
Owner Name	Mr. Surendra Sharma
Khata No	210
Plot No	3862
Village Name	Mango
Use	Residential
SubUse	Bungalow/ Dwelling / Non Apartment

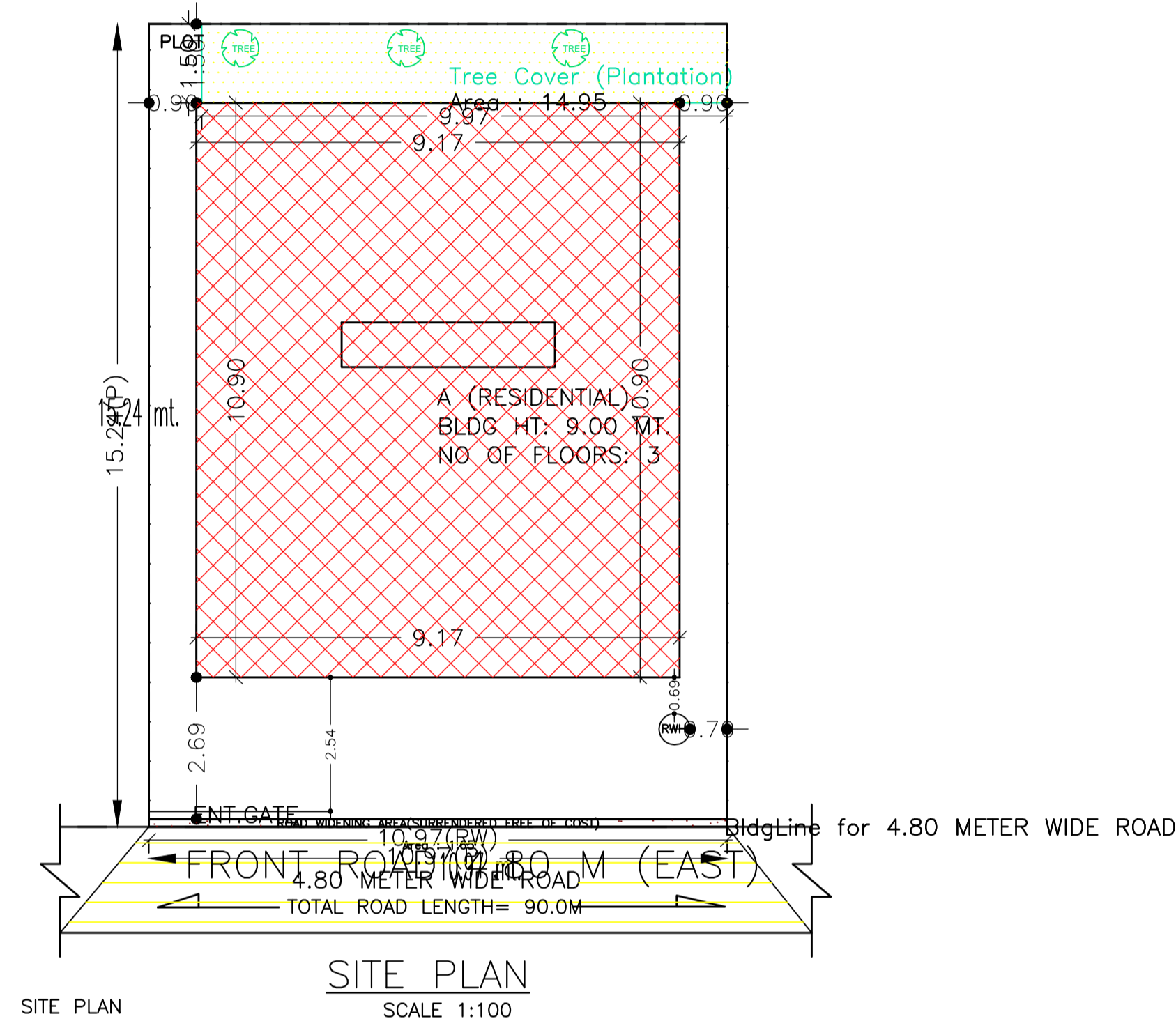

Buildingwise Floor FAR Details

Floor Name	Building Name A (RESIDENTIAL)		Total	
	Proposed Built Up Area (Sq.mt.)	Proposed FAR Area (Sq.mt.)	Total Proposed Built Up Area (Sq.mt.)	Total FAR Area (Sq.mt.)
Ground Floor	99.95	22.70	99.95	22.70
First Floor	99.95	99.95	99.95	99.95
Second Floor	99.95	99.95	99.95	99.95
Terrace Floor	0.00	0.00	0.00	0.00
Total :	299.85	222.60	299.85	222.60

COLOR INDEX	
PLOT BOUNDARY	Black
ABUTTING ROAD	Green
PROPOSED CONSTRUCTION	Red
COMMON PLOT	Yellow
ROAD WIDENING AREA	Orange
EXISTING (To be retained)	Blue
EXISTING (To be demolished)	Light Blue

Building USE/SUBUSE Details

Building Name	Building Use	Building SubUse	Building Structure
A (RESIDENTIAL)	Residential	Residential Bldg/Apartment	Non-Highrise

FAR & Tenement Details (Table 4c-1)

Building	No. of Same Bldg	Total Built Up Area (Sq.mt.)	Deductions (Area in Sq.mt.)	Proposed FAR Area (Sq.mt.)	Add Area in FAR (Sq.mt.)	Total FAR Area (Sq.mt.)	Total Consumed Additional FAR Area (Sq.mt.)	Tnmt (No.)
A (RESIDENTIAL)	1	299.85	77.25	213.60	9.00	222.60	222.60	01
Grand Total :	1	299.85	77.25	213.60	9.00	222.60	222.60	01

AREA STATEMENT MANGO MUNICIPAL CORPORATION	VERSION NO.: 1.0.61	
	VERSION DATE: 16/10/2020	
PROJECT DETAIL:		
Region: JHARKHAND	Plot Use: Residential	
URBAN LOCAL BODIES	Plot SubUse: Bungalow/ Dwelling / Non Apartment	
District: EAST SINGHBHUM	PlotNearbyReligiousStructure: NA	
Authority: MANGO MUNICIPAL CORPORATION	Plot/SubPlot No: 3862	
Inward_No: MNAC/BP/0060/W10/2021	North: Plot No. - 3863	
Application Type: General Proposal	South: Plot No. - 3860	
Project Type: Building Permission	East: Road Width - 4.80	
Nature of Development: New	West: Road Width - 2263	
Location of Development Area: Old Area		
AREA DETAILS:	SQ.MT.	
AREA OF PLOT (Minimum)	(A)	167.18
Deduction for NetPlot Area		
Surrender Free of Cost		1.65
Total		1.65
NET AREA OF PLOT(Gross Plot Area - Deduction from Gross Plot area)	(A-Deductions)	165.53
Deduction for Balance Plot Area(from Gross Plot Area)		
Surrender Free of Cost		1.65
Common Plot		14.96
Total		16.60
BALANCE AREA OF PLOT(Net Plot Area - Recreational/Amenity space)	(A-Deductions)	150.58
PLOT AREA FOR COVERAGE(Net Plot Area)	(A-Deductions)	165.53
Plot Area for FAR (Net Plot Area + RoadWidening Area)	(A-Deductions)	167.18
COVERAGE CHECK		
Permissible Coverage area (70.00 %)		115.87
Proposed Coverage Area (60.38 %)		99.95
Total Prop. Coverage Area (60.38 %)		99.95
Balance coverage area (9.62 %)		15.92
FAR CHECK		
Perm. FAR Area (1.80)		300.92
Total Perm. FAR area		300.92
Residential FAR		213.61
Proposed FAR Area		222.61
Total Proposed FAR Area		222.61
Consumed FAR (Factor)		1.33
Balance FAR Area		78.31
BUILT UP AREA CHECK		
Total Proposed BuiltUp Area		299.85
ARCHITECT (Regd)	Chandrika Sharma	
ENGINEER (Regd)		
SUPERVISOR (Regd)		
OWNER (Regd)	Mr. Surendra Sharma	
DEVELOPMENT AUTHORITY		LOCAL BODY

LTP NAME AND SIGNATURE	STRUCTURAL ENG'S NAME AND SIGNATURE	DESIGNER NAME AND SIGNATURE	REAL SIGNATURE
Chandrika Sharma MNAC/DFTMN/0017/2017			

Proposal Basic Information	
Proposal File No	MNAC/BP/0060/W10/2021
Owner Name	Mr. Surendra Sharma
Khata No	210
Plot No	3862
Village Name	Mango
Use	Residential
SubUse	Bungalow/ Dwelling / Non Apartment

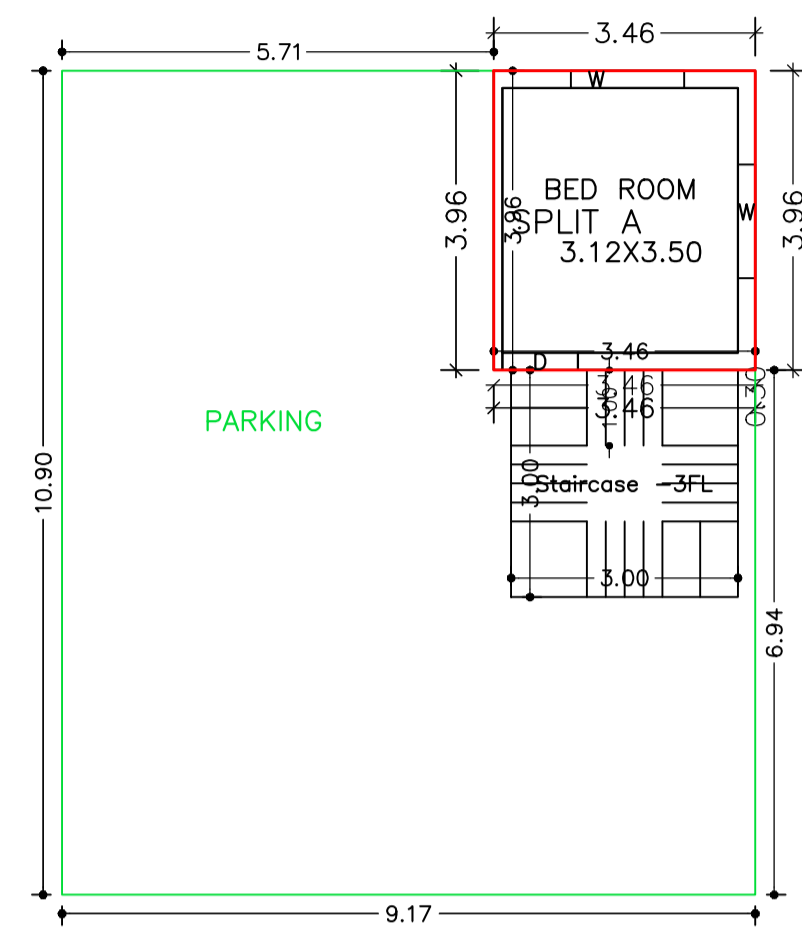

GROUND FLOOR PLAN
(Proposed)
(SCALE 1:100)

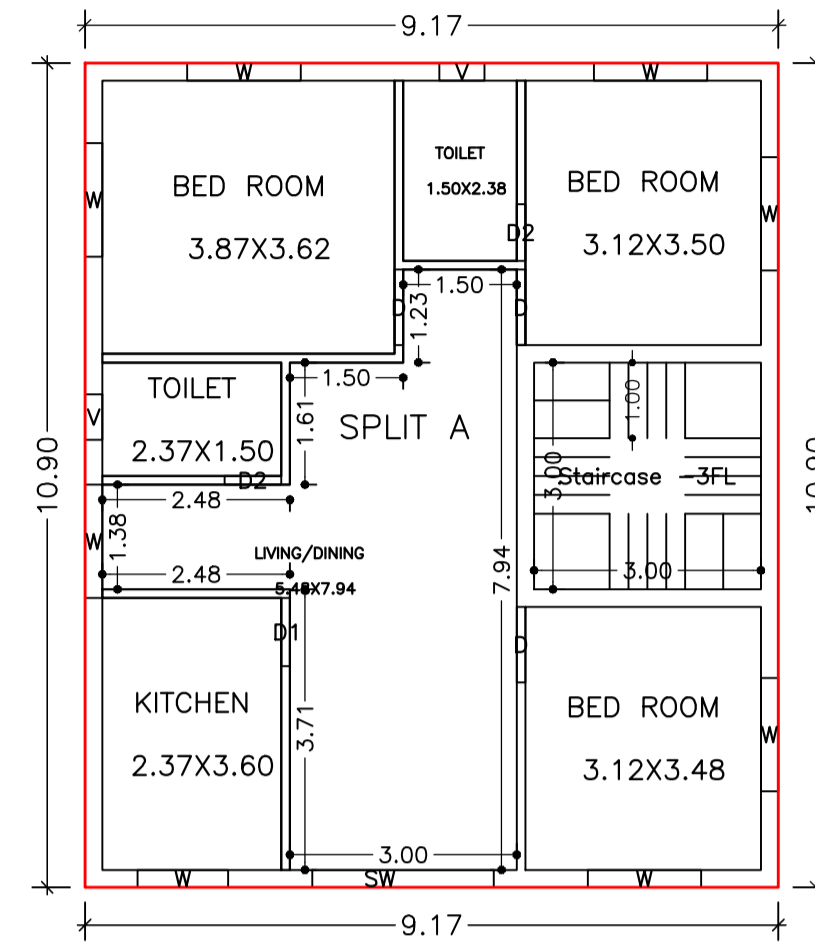

TYPICAL - 1& 2 FLOOR PLAN
(Proposed)
(SCALE 1:100)

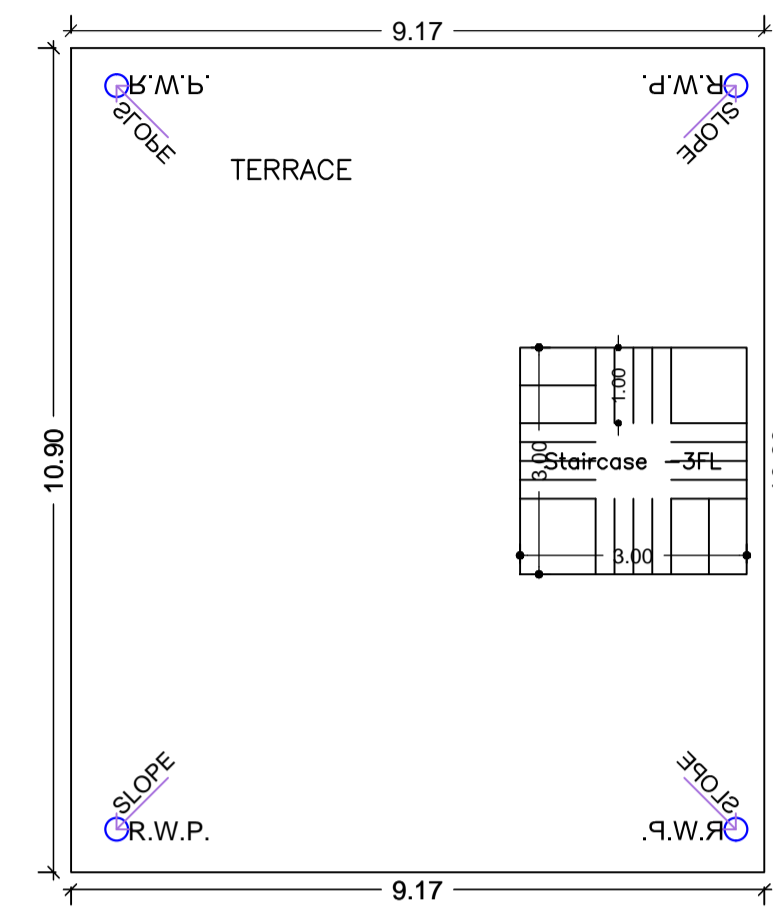

TERRACE FLOOR PLAN
(SCALE 1:100)

Building :A (RESIDENTIAL)

Floor Name	Total Built Up Area (Sq.mt.)	Deductions (Area in Sq.mt.)	Proposed FAR Area (Sq.mt.)	Add Area in FAR (Sq.mt.)	Total FAR Area (Sq.mt.)	Total Consumed Additional FAR Area (Sq.mt.)	Tnmt (No.)
Ground Floor	99.95	77.25	13.70	9.00	22.70	22.70	01
First Floor	99.95	0.00	99.95	0.00	99.95	99.95	00
Second Floor	99.95	0.00	99.95	0.00	99.95	99.95	00
Terrace Floor	0.00	0.00	0.00	0.00	0.00	0.00	00
Total :	299.85	77.25	213.60	9.00	222.60	222.60	01
Total Number of Same Buildings :	1						
Total :	299.85	77.25	213.60	9.00	222.60	222.60	01

SCHEDULE OF DOOR:

BUILDING NAME	NAME	LENGTH	HEIGHT	NOS
A (RESIDENTIAL)	D2	0.75	2.10	04
A (RESIDENTIAL)	D1	0.90	2.10	02
A (RESIDENTIAL)	D	1.00	2.10	07

SCHEDULE OF WINDOW/VENTILATION:

BUILDING NAME	NAME	LENGTH	HEIGHT	NOS
A (RESIDENTIAL)	V	0.60	0.75	04
A (RESIDENTIAL)	W	1.20	1.20	02
A (RESIDENTIAL)	W	1.50	1.20	16
A (RESIDENTIAL)	SW	2.40	2.10	02

UnitBUA Table for Building :A (RESIDENTIAL)

FLOOR	Name	UnitBUA Type	UnitBUA Area	Carpet Area	No. of Rooms	No. of Tenement
GROUND FLOOR PLAN	SPLIT A	FLAT	173.21	165.44	1	1
TYPICAL - 1& 2 FLOOR PLAN	SPLIT A	FLAT	0.00	0.00	7	0
Total:	-	-	173.21	165.44	15	1

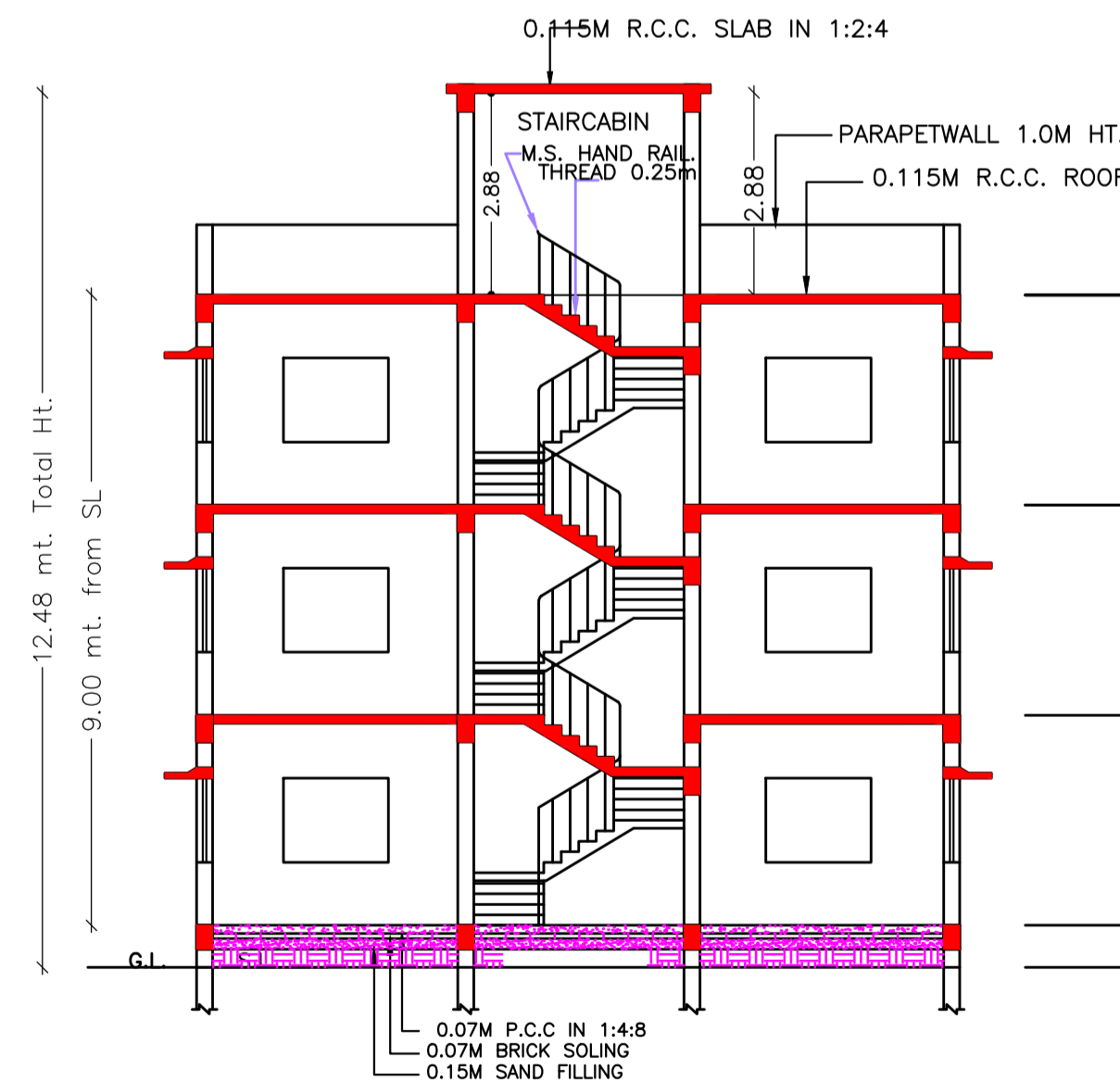

SECTION -AA
SCALE 1:100

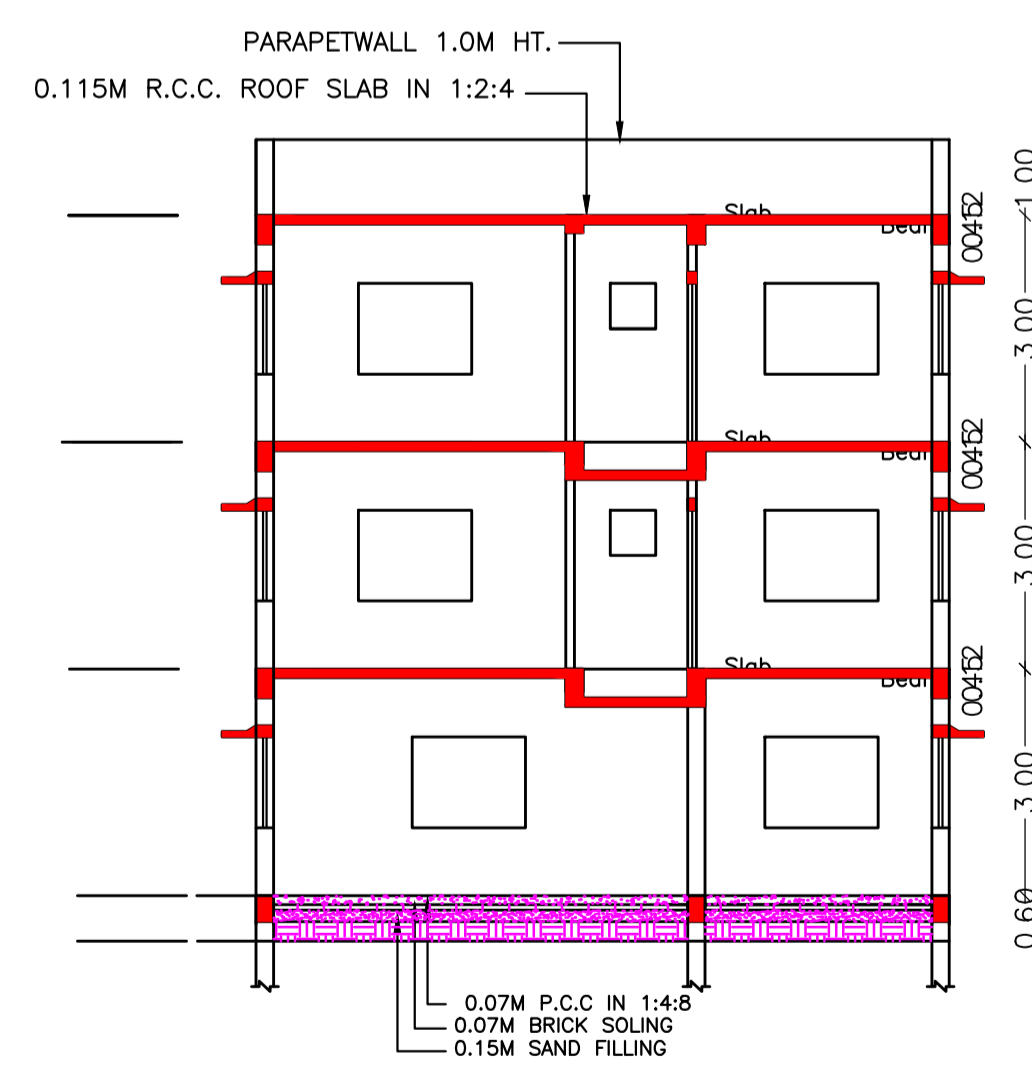

SECTION -BB
SCALE 1:100

LTP NAME AND SIGNATURE	STRUCTURAL ENG'S NAME AND SIGNATURE	SI/VA/DERNAME AND SIGNATURE	AUREAL SIGNATURE
Chandrika Sharma MNAC/DFTMN/0017/2017			

Proposal Basic Information	
Proposal File No	MNAC/BP/0060/W10/2021
Owner Name	Mr. Surendra Sharma
Khata No	210
Plot No	3862
Village Name	Mango
Use	Residential
SubUse	Bungalow/ Dwelling / Non Apartment

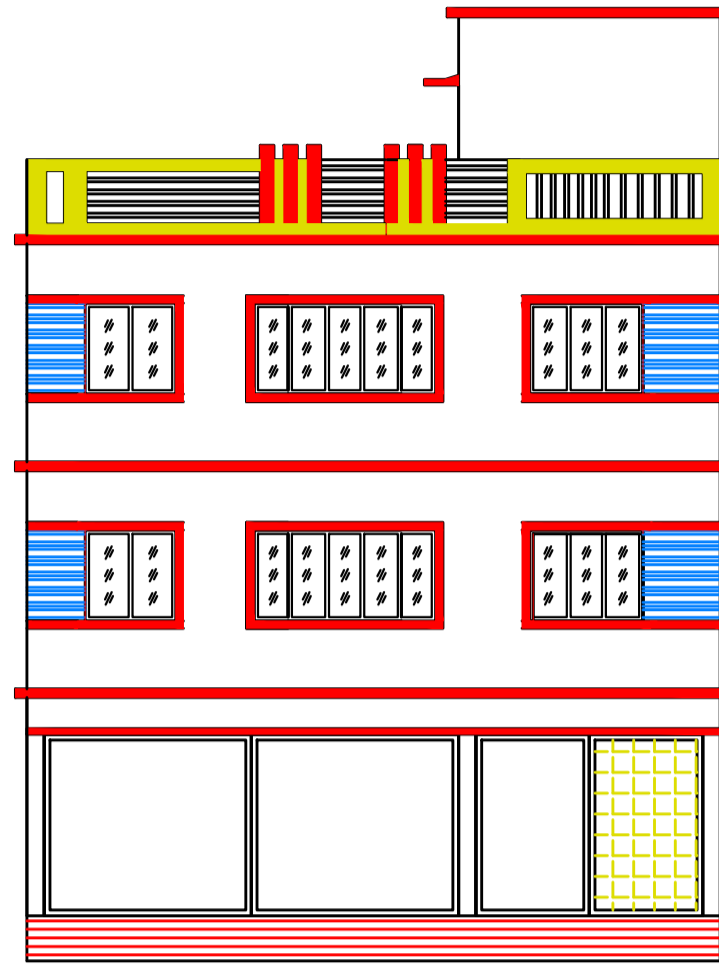

FRONT ELEVATION
SCALE 1:100

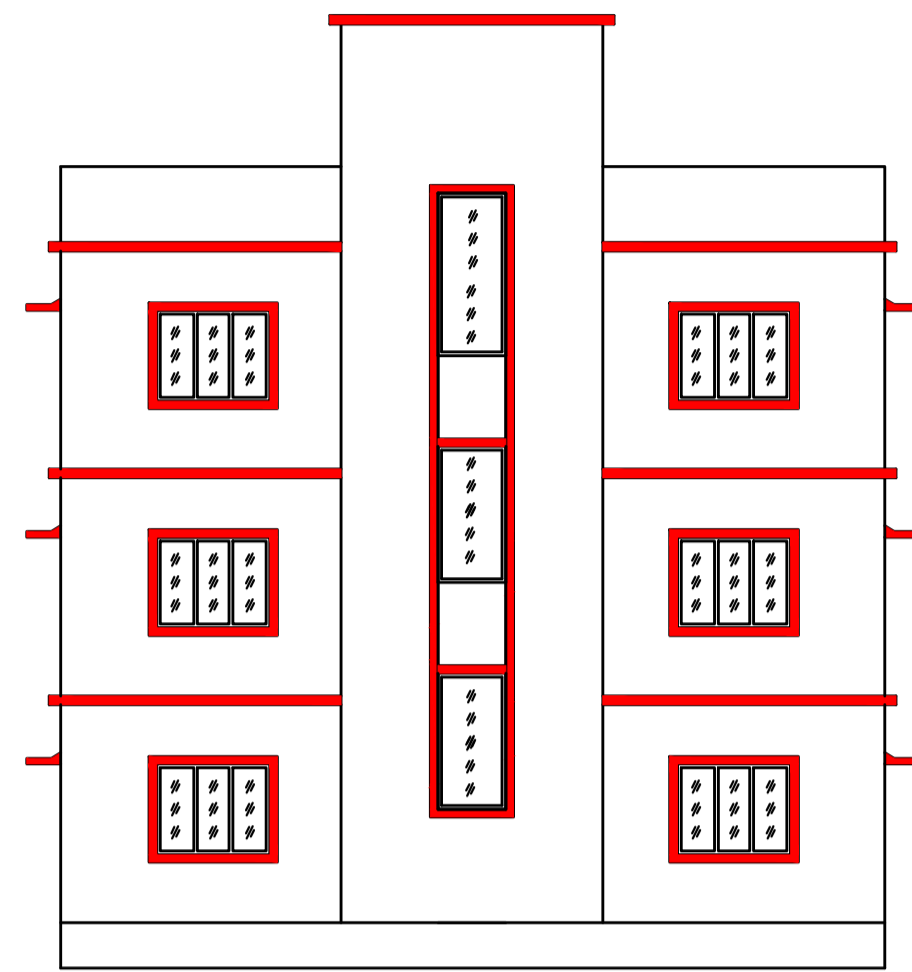

SIDE ELEVATION
SCALE 1:100

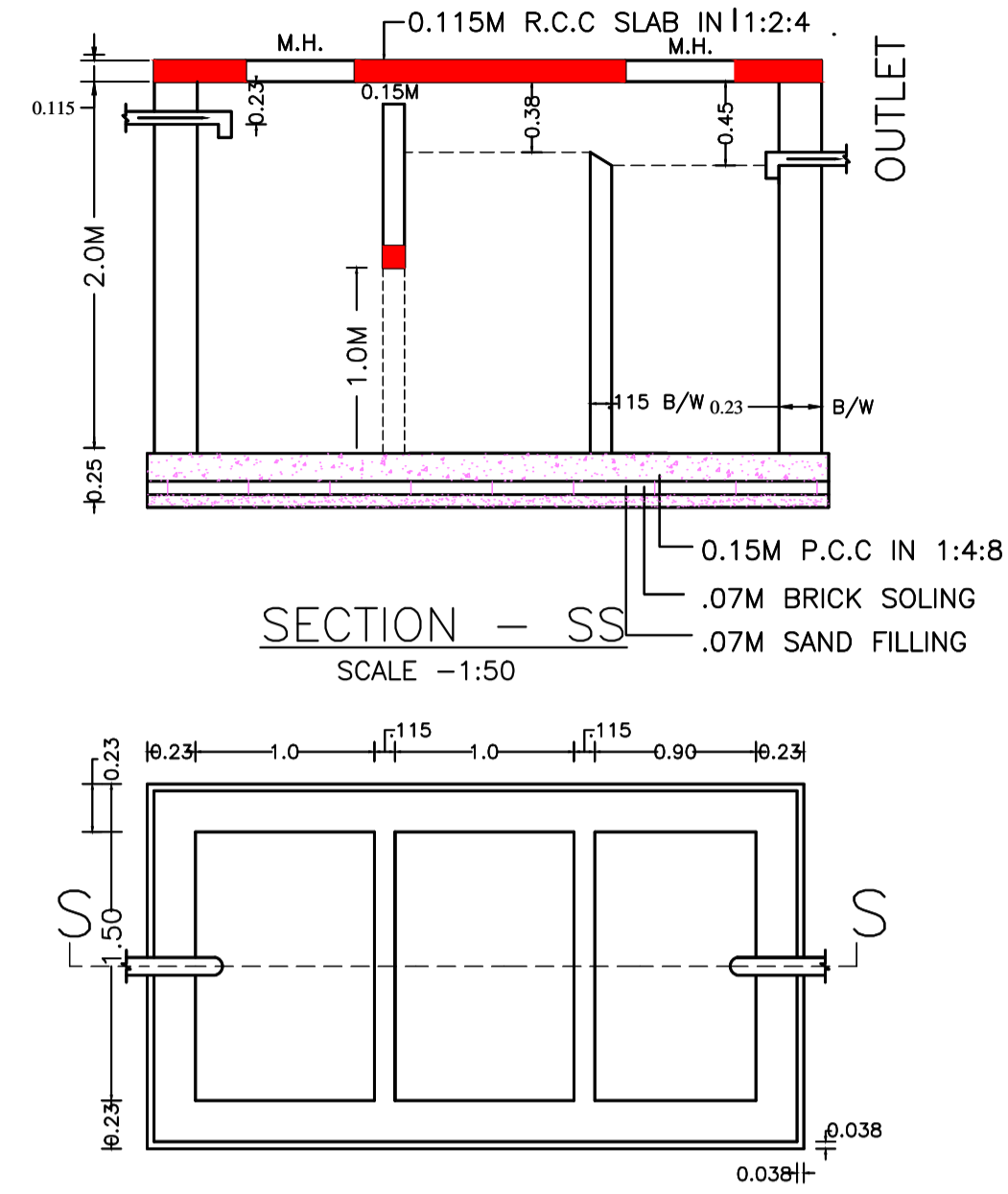

SECTION - SS
SCALE -1:50

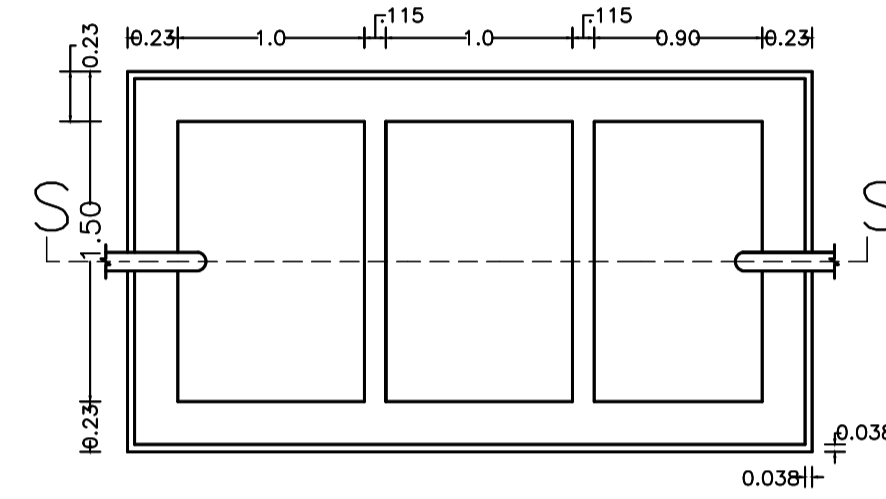

SEPTIC TANK PLAN
SCALE -1:50

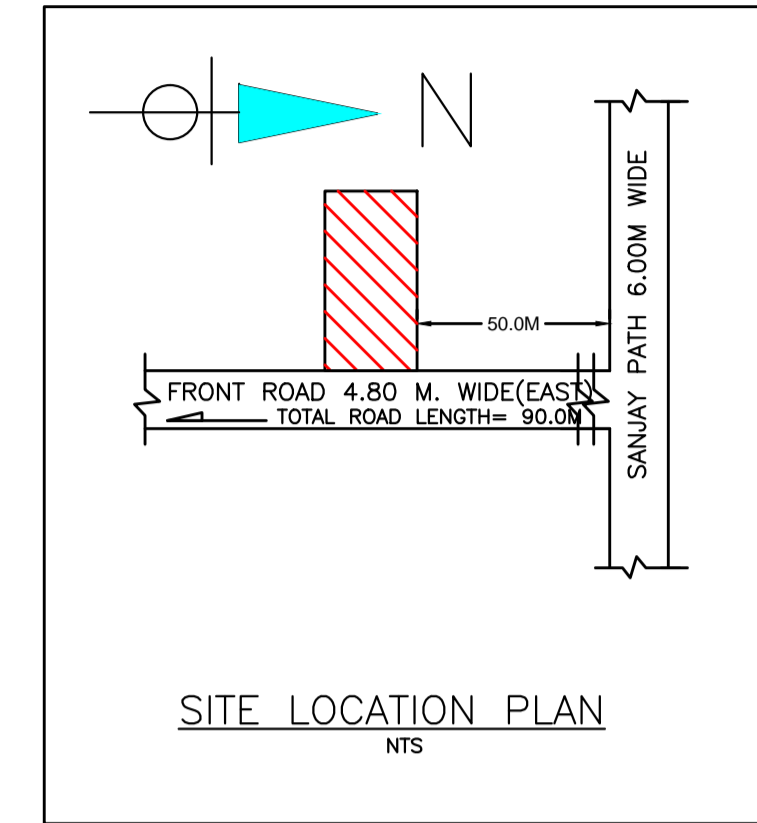

SITE LOCATION PLAN
NTS

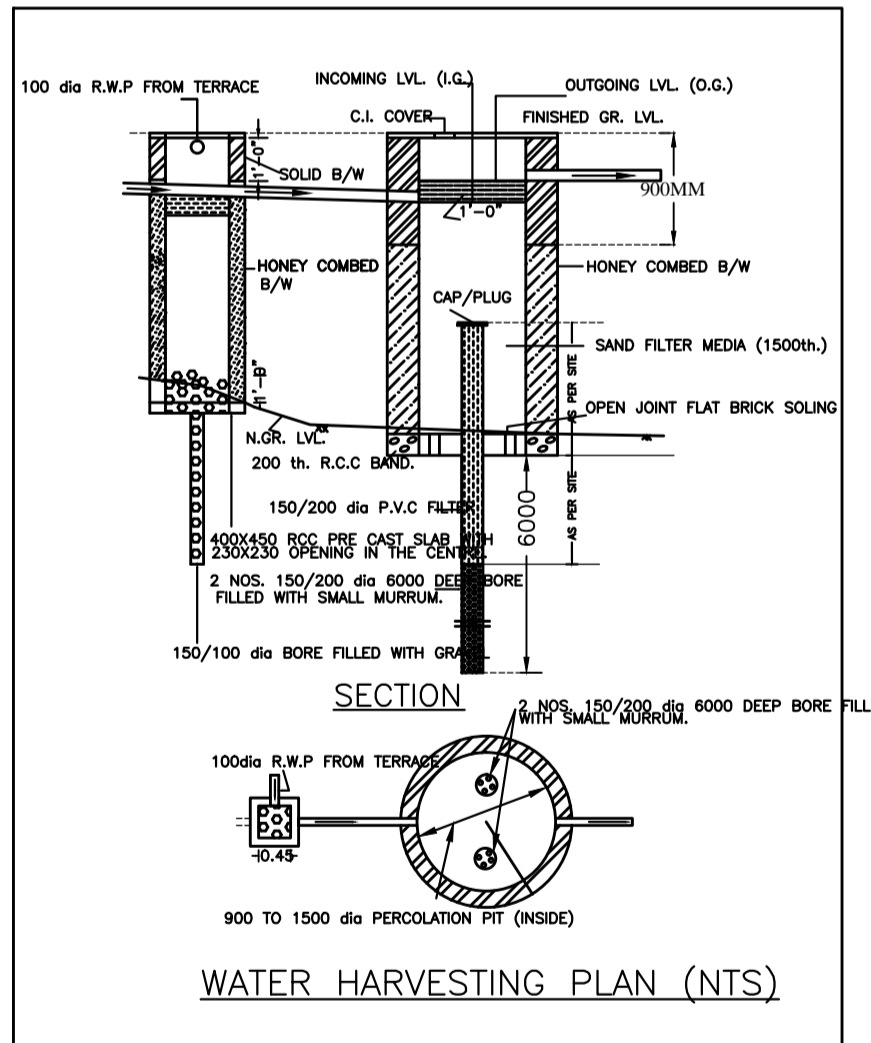

SECTION
WATER HARVESTING PLAN (NTS)

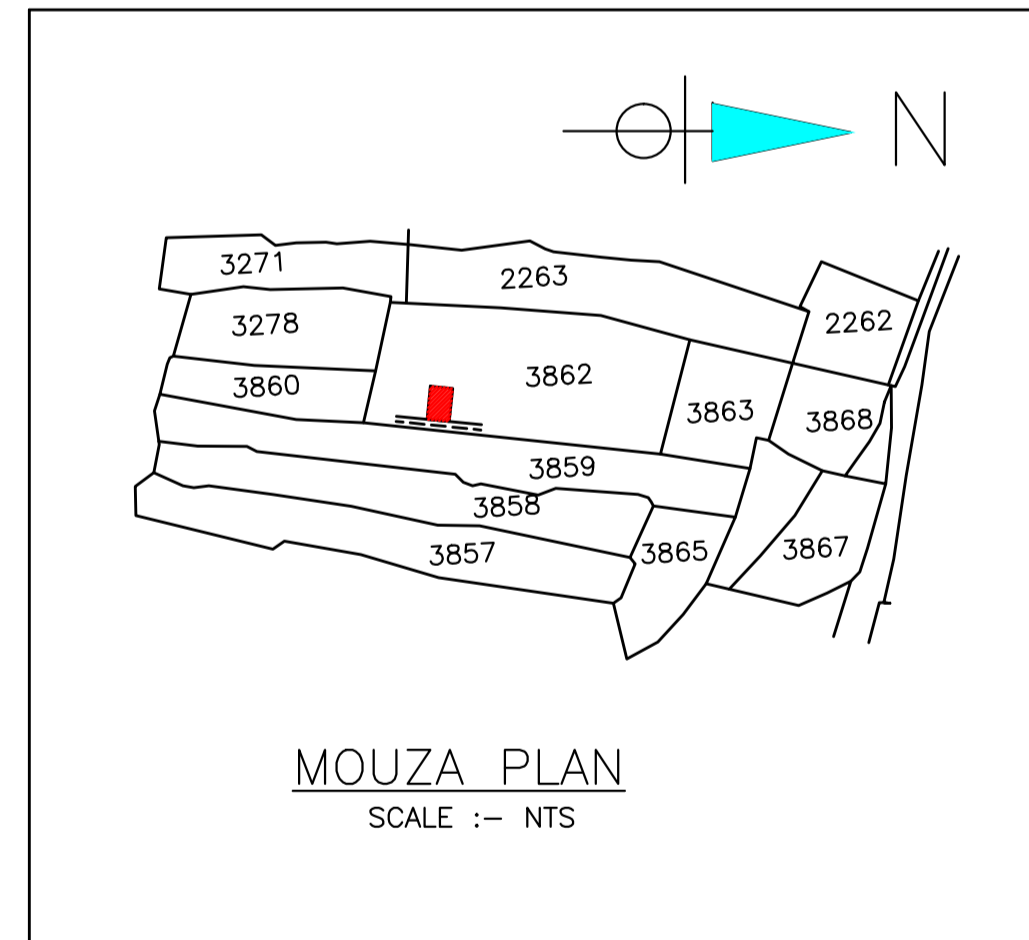

MOUZA PLAN
SCALE :- NTS

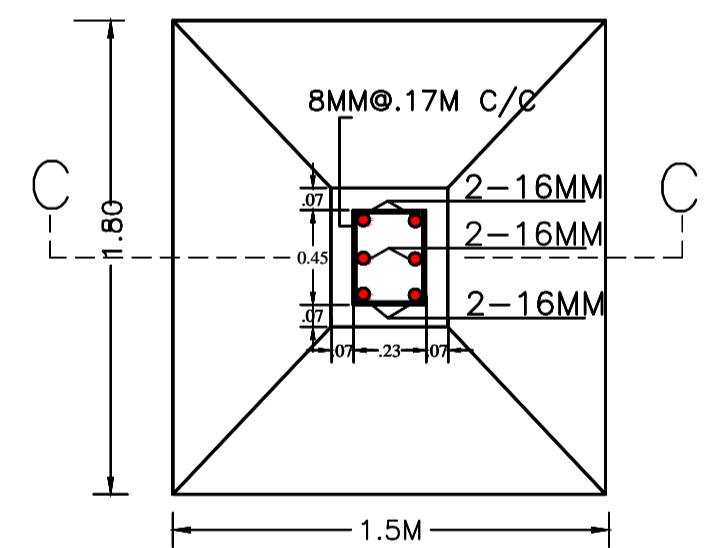

R.C.C. COL. FDN. PLAN
SCALE -1:25

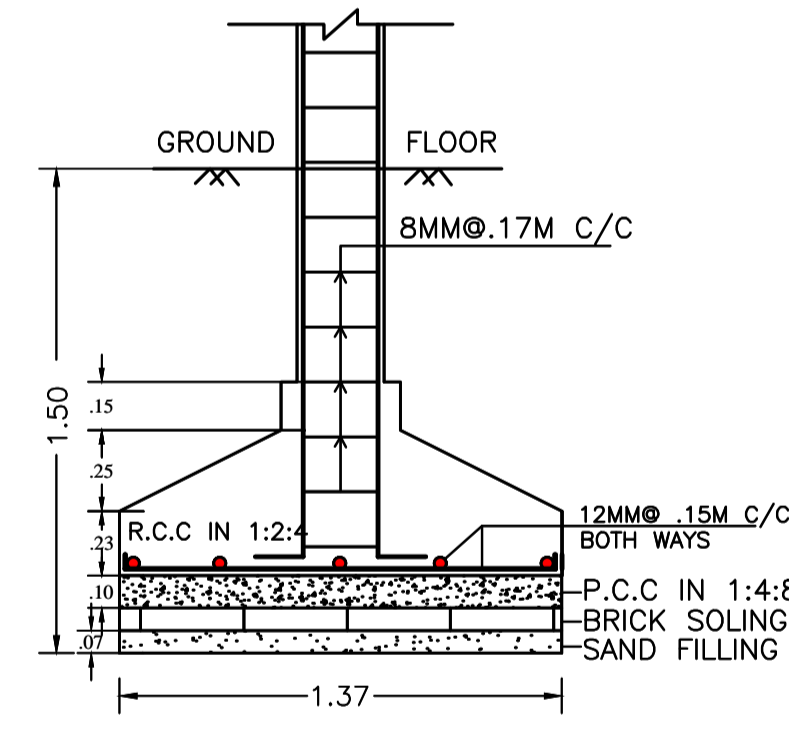

SECTION - CC
SCALE -1:25

LTP NAME AND SIGNATURE	STRUCTURAL ENG'S NAME AND SIGNATURE	DESIGNER NAME AND SIGNATURE	AUTHORIAL SIGNATURE
Chandrika Sharma MNAC/DFTMN/0017/2017			