

S/No	TYPE	LENGTH	HEIGHT	SILL LEV.	LINTEL LEV.	DESCRIPTION
1	D	1.20M	2.10M	0.00	2.1	SOLID CORE FLUSH DOOR
2	D1	0.90M	2.10M	0.00	2.1	SOLID CORE FLUSH DOOR
3	D2	0.75M	2.10M	0.00	2.1	SOLID CORE FLUSH DOOR
4	W6	1.80M	1.20M	0.90	2.1	FULLY GLASSED STEEL WINDOW
5	W4	1.20M	1.20M	0.90	2.1	FULLY GLASSED STEEL WINDOW
6	W3	0.90M	1.20M	0.90	2.1	FULLY GLASSED STEEL WINDOW
7	Wk	0.90M	1.20M	0.90	2.1	FULLY GLASSED STEEL WINDOW
8	V	0.60M	0.60M	1.50	2.1	FULLY GLASSED VENTILATION

Note- this detail is applicable in all floor.

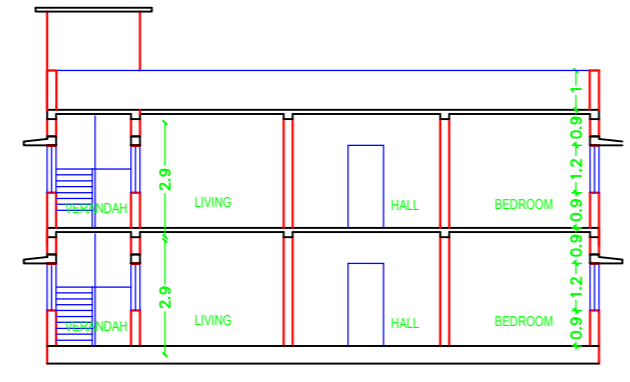

SECTION -X-X'
SCALE : 1:100

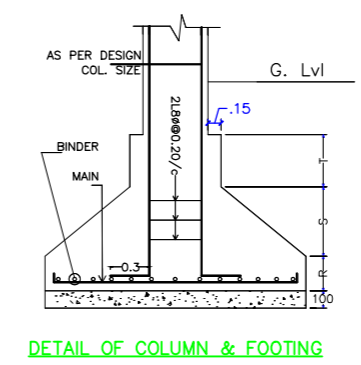
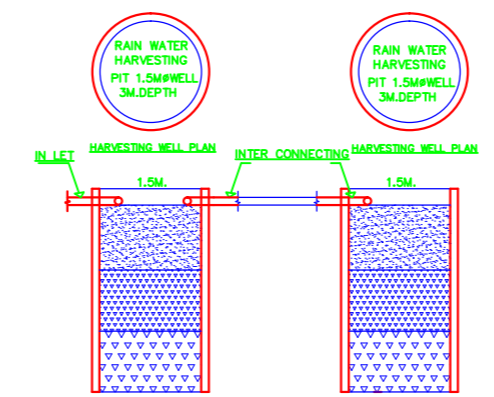
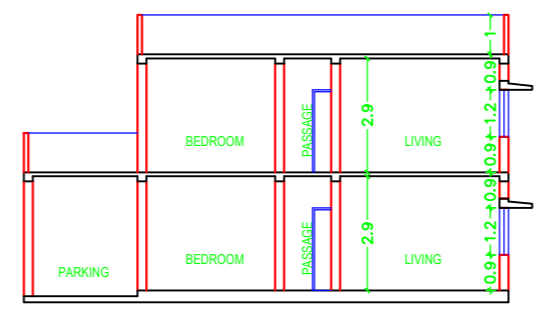

SECTION -Y-Y'
SCALE : 1:100

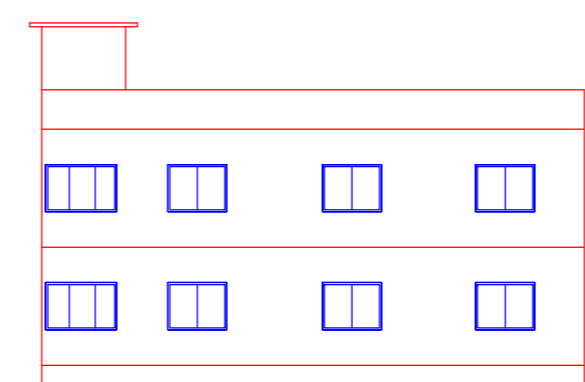

FRONT ELEVATION
SCALE : 1:100

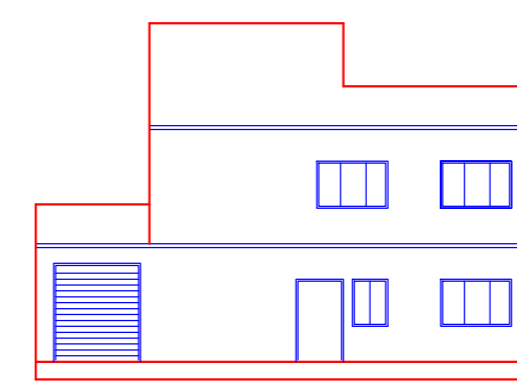

REAR ELEVATION
SCALE : 1:100

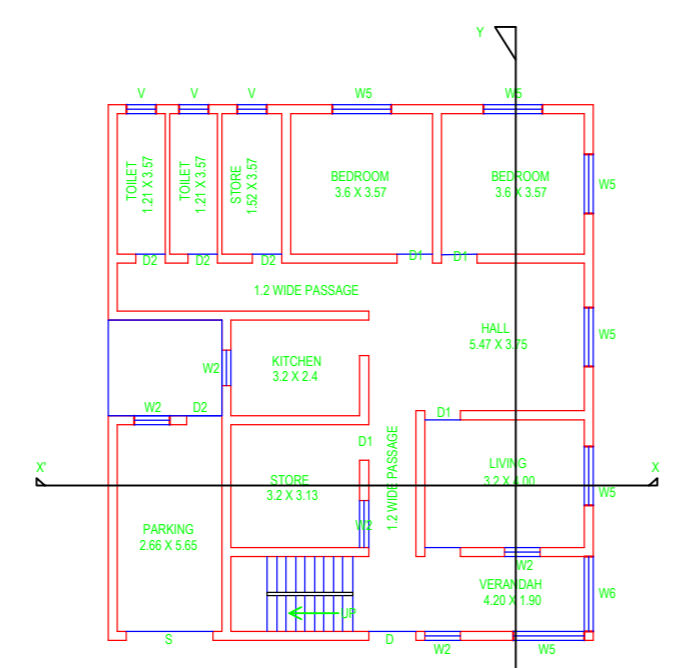
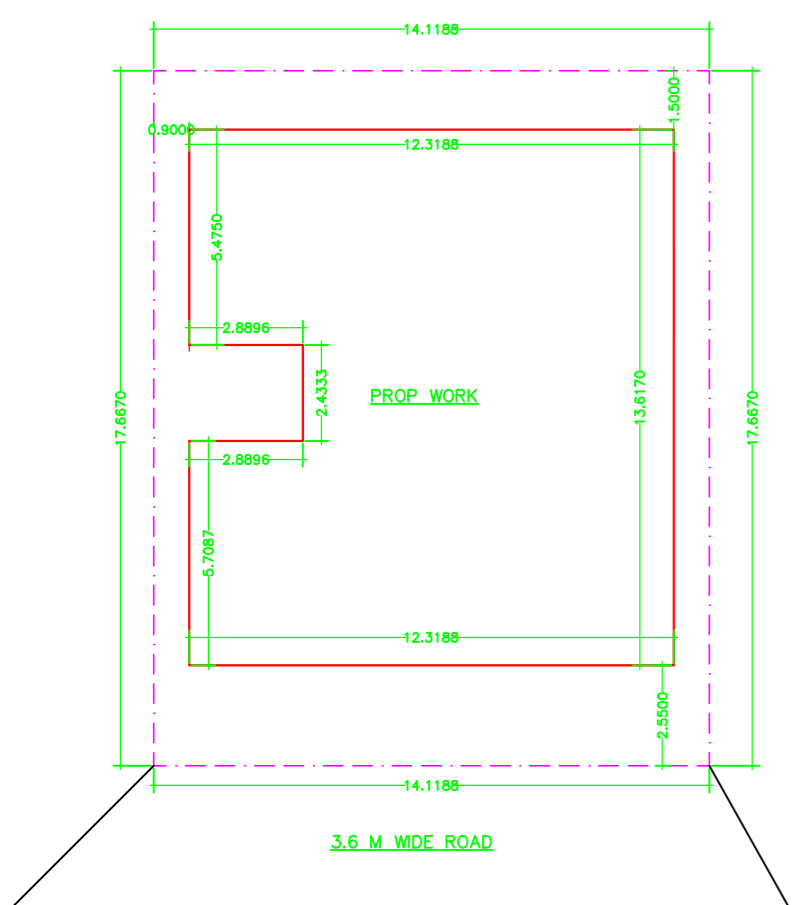

EXISTING GROUND FLOOR PLAN
SCALE : 1:100

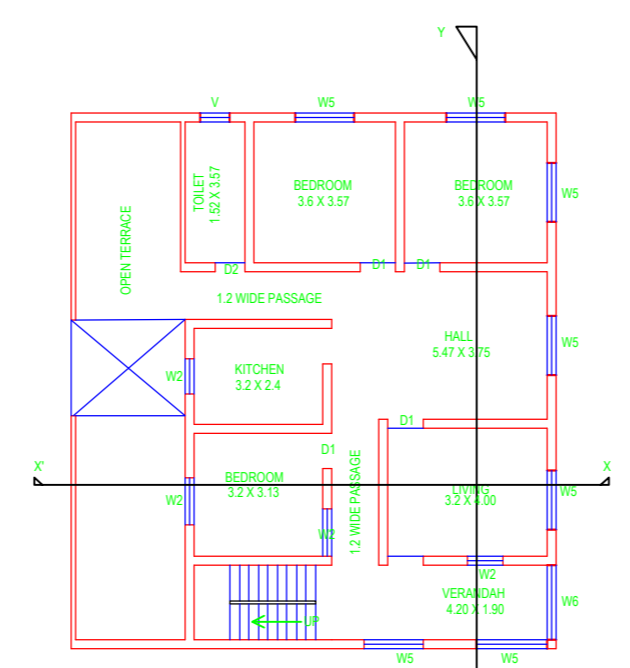

EXISTING 1ST FLOOR PLAN
SCALE : 1:100

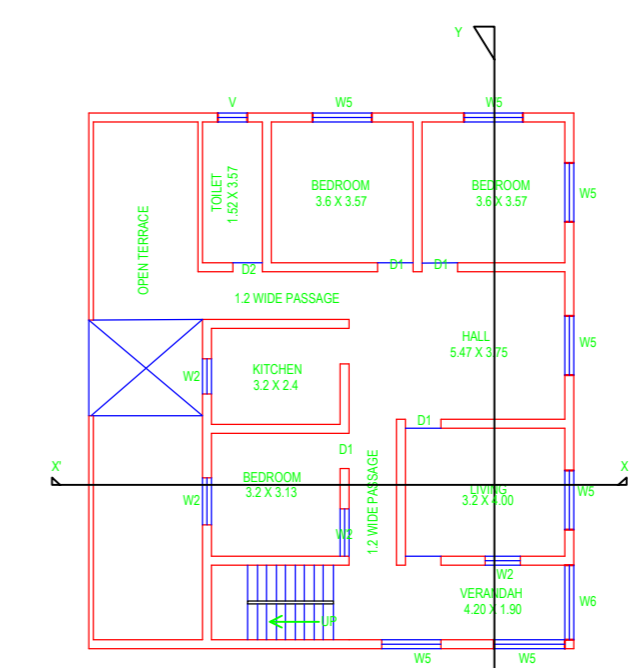

PROPOSED FIRST FLOOR PLAN
SCALE : 1:100

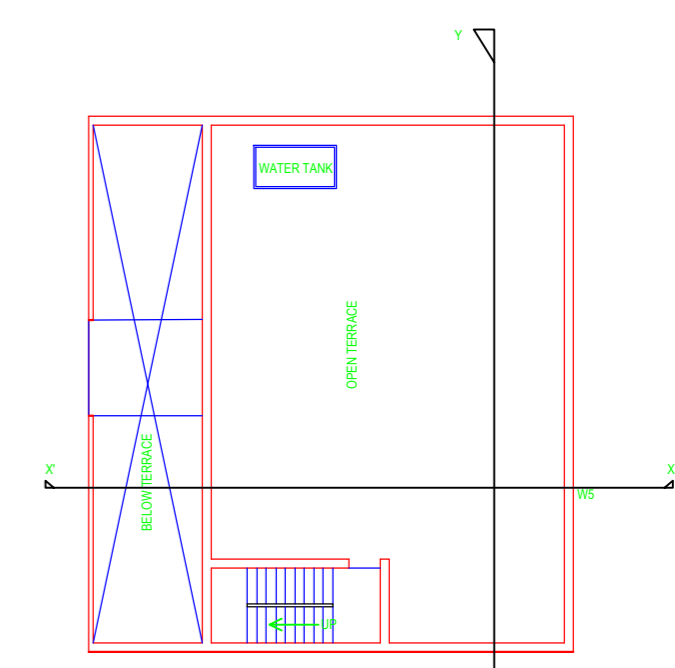

ROOF PLAN
SCALE : 1:100