

SCHEDULE OF DOOR:

BUILDING NAME	NAME	LENGTH	HEIGHT	NOS
A (RESIDENTIAL)	D2	0.75	2.10	06
A (RESIDENTIAL)	D3	0.90	2.10	02
A (RESIDENTIAL)	D1	0.95	2.10	04
A (RESIDENTIAL)	D0	1.05	2.10	02

SCHEDULE OF WINDOW/VENTILATION:

BUILDING NAME	NAME	LENGTH	HEIGHT	NOS
A (RESIDENTIAL)	V	0.60	0.75	04
A (RESIDENTIAL)	W4	1.20	1.20	04
A (RESIDENTIAL)	W5	1.50	1.20	12

Building :A (RESIDENTIAL)

Floor Name	Total Built Up Area (Sq.mt.)	Deductions (Area in Sq.mt.)	Proposed FAR Area (Sq.mt.)	Add Area In FAR (Sq.mt.)	Total FAR Area (Sq.mt.)	Total Consumed Additional FAR Area (Sq.mt.)	Tnmt (No.)
Ground Floor	77.05	69.22	0.00	7.83	7.83	7.83	00
First Floor	76.45	0.00	76.45	0.00	76.45	76.45	01
Second Floor	76.45	0.00	76.45	0.00	76.45	76.45	01
Terrace Floor	0.00	0.00	0.00	0.00	0.00	0.00	00
Total :	229.95	69.22	152.90	7.83	160.73	160.73	02
Total Number of Same Buildings :	1						
Total :	229.95	69.22	152.90	7.83	160.73	160.73	02

Required Parking (Table 7a)

Building Name	Type	SubUse	Area (Sq.mt.)	Units		Car		Visitors Car			
				Reqd.	Prop.	Reqd./Unit	Reqd.	Prop.	Reqd./Unit	Reqd.	Prop.
A (RESIDENTIAL)	Residential	Bungalow/ Dwelling / Non Apartment	> 0	1	2.00	1.00	2	-	-	-	-
			> 0	1	2.00	-	-	-	1	1	-
Total :			-	-	-	-	2	2	-	1	1

Parking Check (Table 7b)

Vehicle Type	Reqd.		Prop.	
	No.	Area	No.	Area
Car	-	-	2	25.00
Total Car	2	25.00	2	25.00
Visitor's Car Parking	-	-	1	12.50
Total Visitor Parking	1	12.50	1	12.50
Other Parking	-	-	-	31.72
Total	37.50		69.22	

Buildingwise Floor FAR Details

Floor Name	Building Name A (RESIDENTIAL)		Total	
	Proposed Built Up Area (Sq.mt.)	Proposed FAR Area (Sq.mt.)	Total Proposed Built Up Area (Sq.mt.)	Total FAR Area (Sq.mt.)
Ground Floor	77.05	7.83	77.05	7.83
First Floor	76.45	76.45	76.45	76.45
Second Floor	76.45	76.45	76.45	76.45
Terrace Floor	0.00	0.00	0.00	0.00
Total :	229.95	160.73	229.95	160.73

FAR & Tenement Details (Table 4c-1)

Building	No. of Same Bldg	Total Built Up Area (Sq.mt.)	Deductions (Area in Sq.mt.)	Proposed FAR Area (Sq.mt.)	Add Area In FAR (Sq.mt.)	Total FAR Area (Sq.mt.)	Total Consumed Additional FAR Area (Sq.mt.)	Tnmt (No.)
A (RESIDENTIAL)	1	229.95	69.22	152.90	7.83	160.73	160.73	02
Grand Total	1	229.95	69.22	152.90	7.83	160.73	160.73	02

UnitBUA Table for Building :A (RESIDENTIAL)

FLOOR	Name	UnitBUA Type	UnitBUA Area	Carpet Area	No. of Rooms	No. of Tenement
TYPICAL - 1& 2 FLOOR PLAN	SPLIT A	FLAT	61.12	57.42	7	2
Total:	-	-	122.23	114.84	14	2

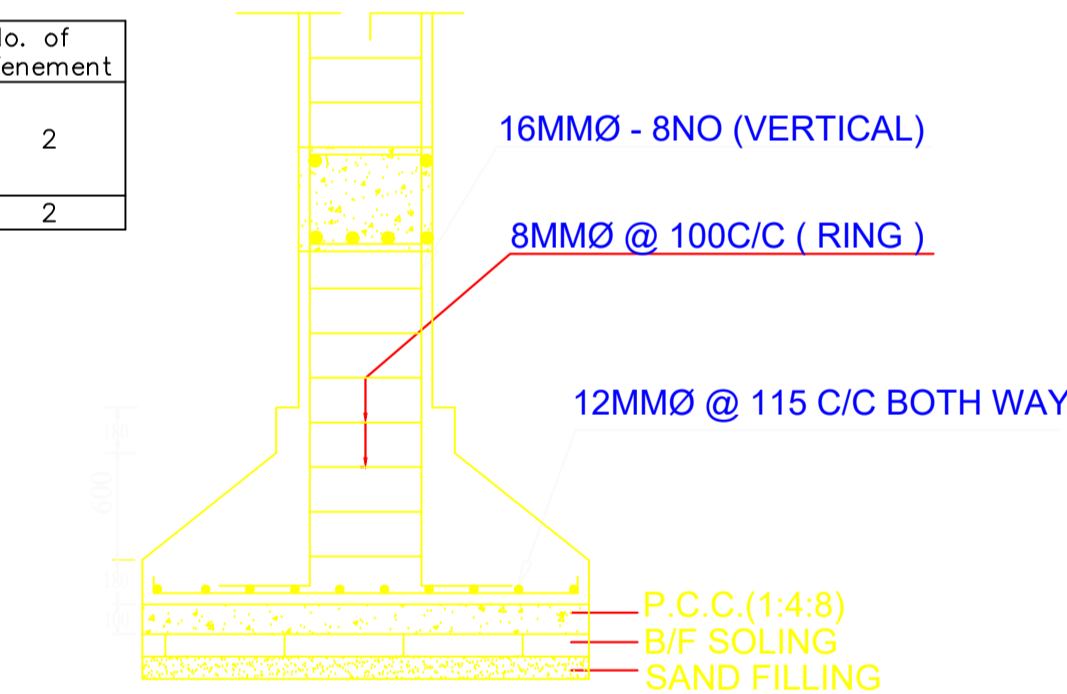

SECTION OF FOUNDATION

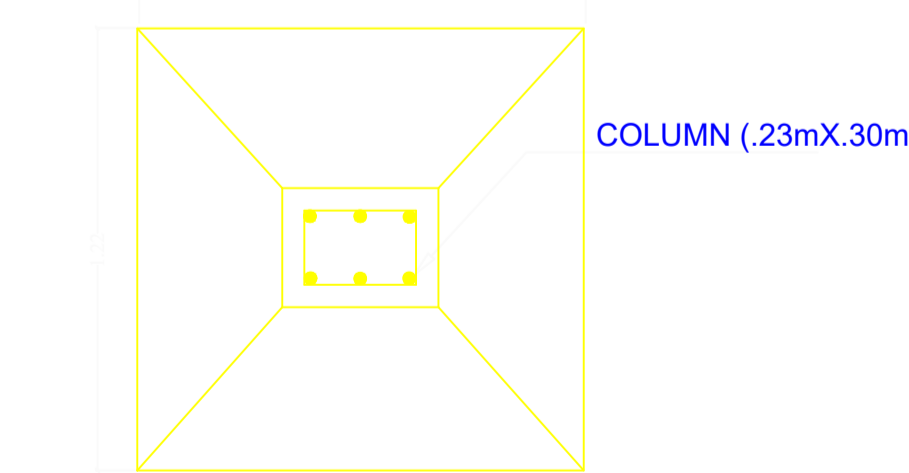

PLAN OF FOUNDATION

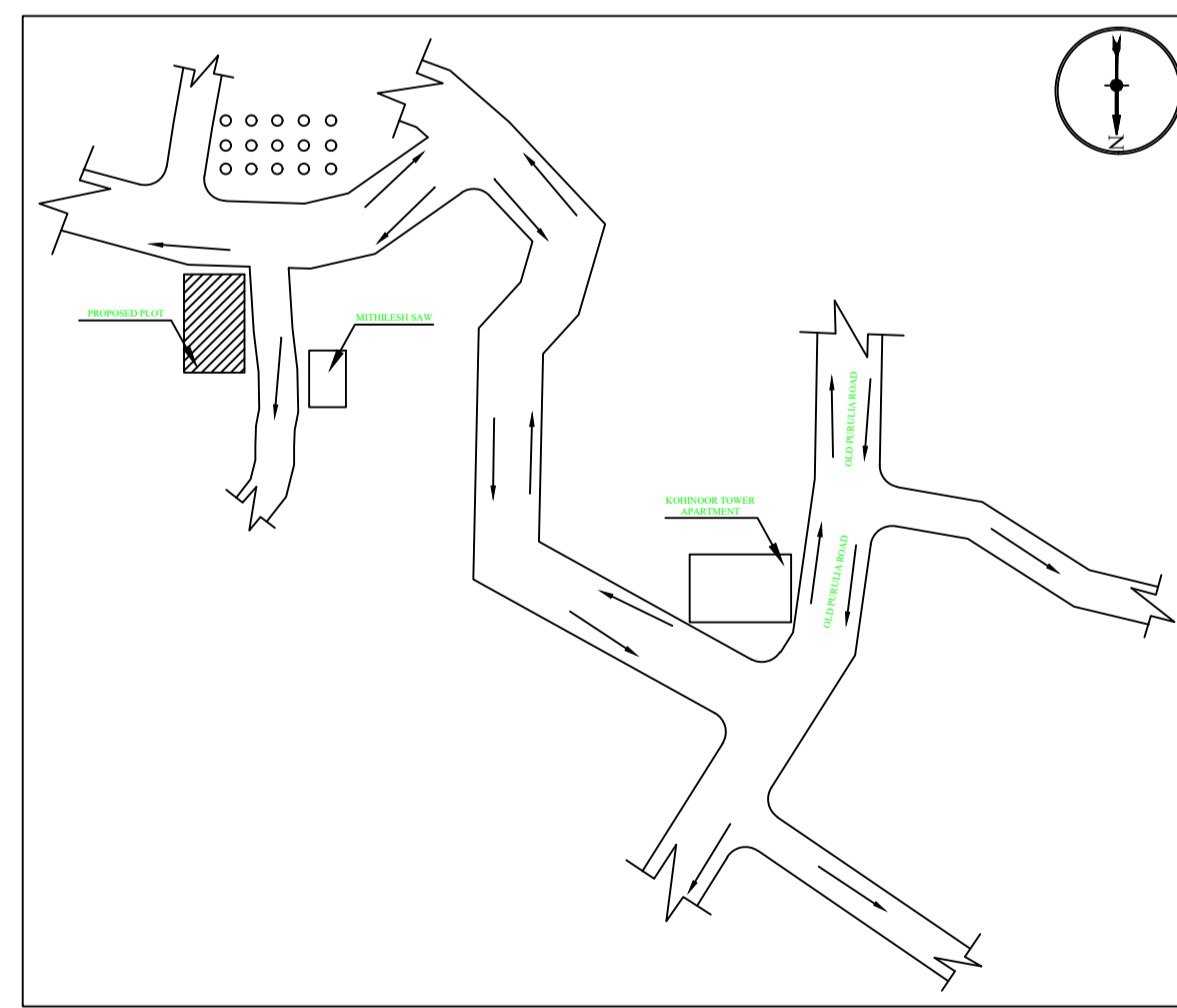
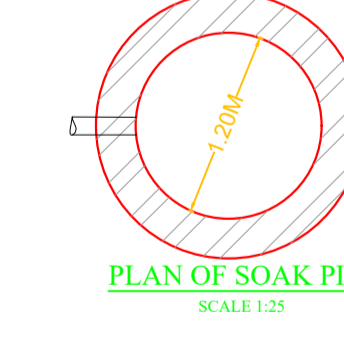
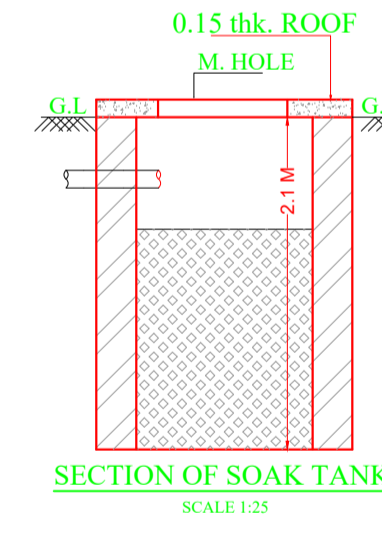
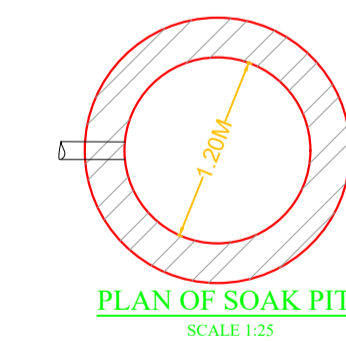
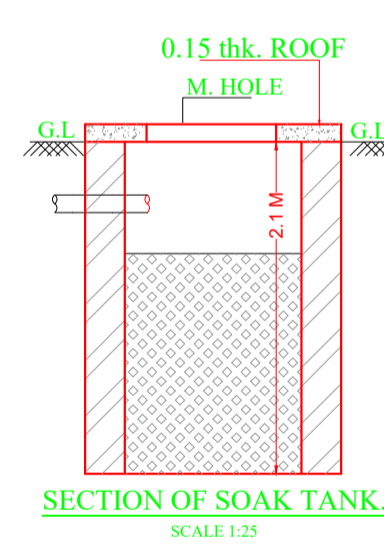

LOCATION PLAN

Proposal Basic Information

Proposal File No	MNAC/BP/0059/W08/2021
Owner Name	smt. rita kumari and others
Khata No	378
Plot No	3091
Village Name	Mango
Use	Residential
SubUse	Bungalow/ Dwelling / Non Apartment

AREA STATEMENT MANGO MUNICIPAL CORPORATION	VERSION NO.: 1.0.62	VERSION DATE: 16/10/2020		
PROJECT DETAIL:	Region: JHARKHAND URBAN LOCAL BODIES	Plot Use: Residential		
District: EAST SINGHBHUM	Plot SubUse: Bungalow/ Dwelling / Non Apartment	PlotNearbyReligiousStructure: NA		
Authority: MANGO MUNICIPAL CORPORATION	Inward_No: MNAC/BP/0059/W08/2021	Plot/SubPlot No: 3091		
Application Type: General Proposal	North: Plot No. - sub plot no-25	South: Road Width - 6.10		
Project Type: Building permission	East: Road Width - 4.5	West: Plot No. - sub plot no-34		
Nature of Development: New	Location of Development Area: New Area	AREA DETAILS:		
		AREA OF PLOT (Minimum)	(A)	130.52
		NET AREA OF PLOT (Gross Plot Area - Deduction from Gross Plot area)	(A-Deductions)	130.52
		Deduction for Balance Plot Area (from Gross Plot Area)		
		Common Plot		7.80
		Total		7.80
		BALANCE AREA OF PLOT (Net Plot Area - Recreational/Amenity space)	(A-Deductions)	122.72
		PLOT AREA FOR COVERAGE (Net Plot Area)	(A-Deductions)	130.52
		Plot Area for FAR (Net Plot Area + Road Widening Area)	(A-Deductions)	130.52
		COVERAGE CHECK		
		Permissible Coverage area (70.00 %)		91.36
		Proposed Coverage Area (59.03 %)		77.05
		Total Prop. Coverage Area (59.03 %)		77.05
		Balance coverage area (10.96 %)		14.31
		FAR CHECK		
		Perm. FAR Area (2.00)		261.04
		Total Perm. FAR area		261.04
		Residential FAR		152.89
		Proposed FAR Area		160.73
		Total Proposed FAR Area		160.73
		Consumed FAR (Factor)		1.23
		Balance FAR Area		100.31
		BUILT UP AREA CHECK		
		Total Proposed BuiltUp Area		229.95
		ARCHITECT (Regd)	sm shahreyar	
		ENGINEER (Regd)		
		SUPERVISOR (Regd)		
		OWNER (Regd)	smt. rita kumari and others	
		DEVELOPMENT AUTHORITY	LOCAL BODY	

Building USE/SUBUSE Details

Building Name	Building Use	Building SubUse	Building Structure
A (RESIDENTIAL)	Residential	Bungalow/ Dwelling / Non Apartment	Non-Highrise

COLOR INDEX	
PLOT BOUNDARY	Black
ABUTTING ROAD	Green
PROPOSED CONSTRUCTION	Red
COMMON PLOT	Yellow
ROAD WIDENING AREA	Blue
EXISTING (To be retained)	Light Blue
EXISTING (To be demolished)	Dark Blue

LTP NAME AND SIGNATURE	STRUCTURAL ENG'S NAME AND SIGNATURE	SIGNATURE AND SIGNATURE	DEVELOPER SIGNATURE
sm shahreyar MNAC/ARC/0026/2017			

Proposal Basic Information

Proposal File No	MNAC/BP/0059/W08/2021
Owner Name	smt. rita kumari and others
Khata No	378
Plot No	3091
Village Name	Mango
Use	Residential
SubUse	Bungalow/ Dwelling / Non Apartment

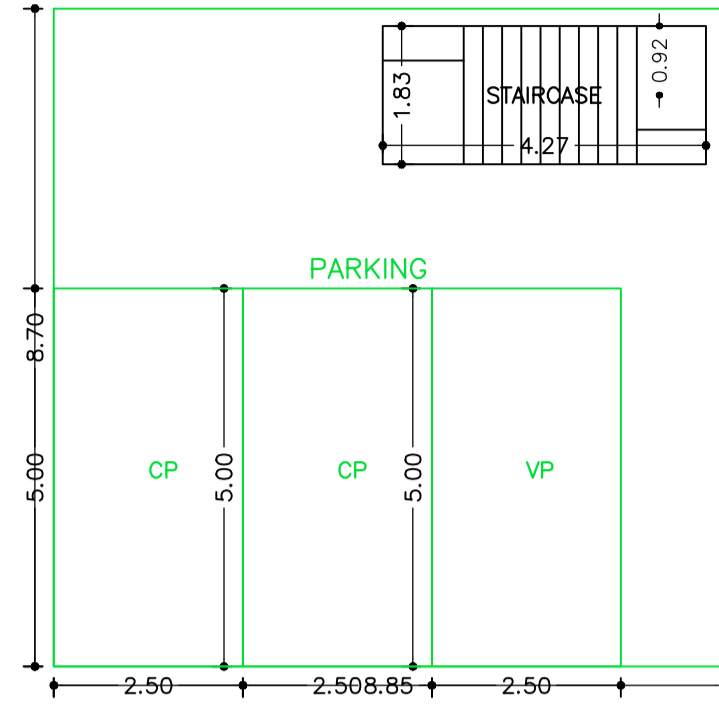

GROUND FLOOR PLAN
(SCALE 1:100)

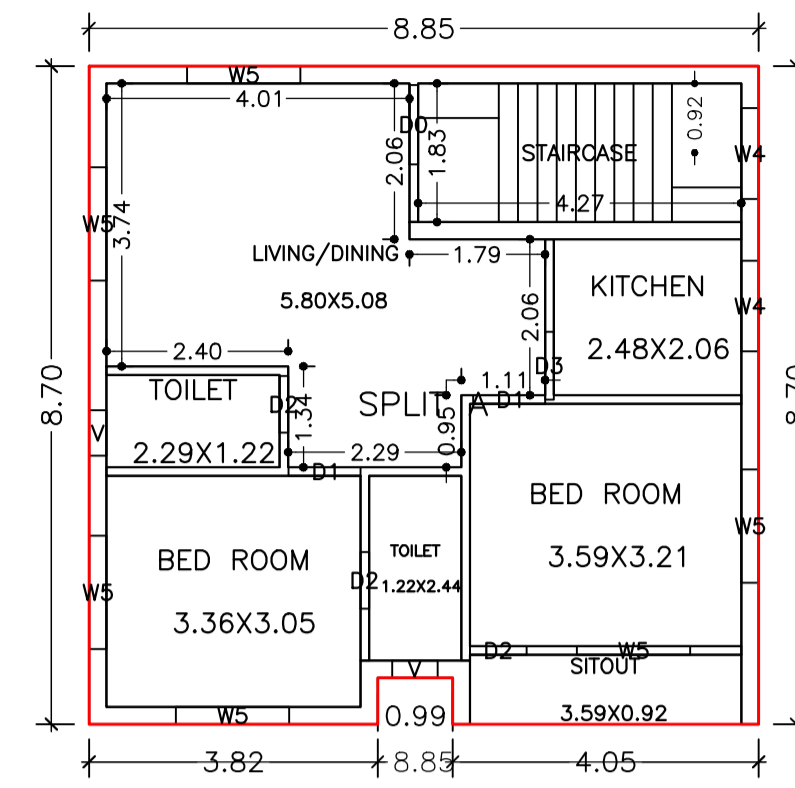

TYPICAL - 1& 2 FLOOR PLAN
(Proposed)
(SCALE 1:100)

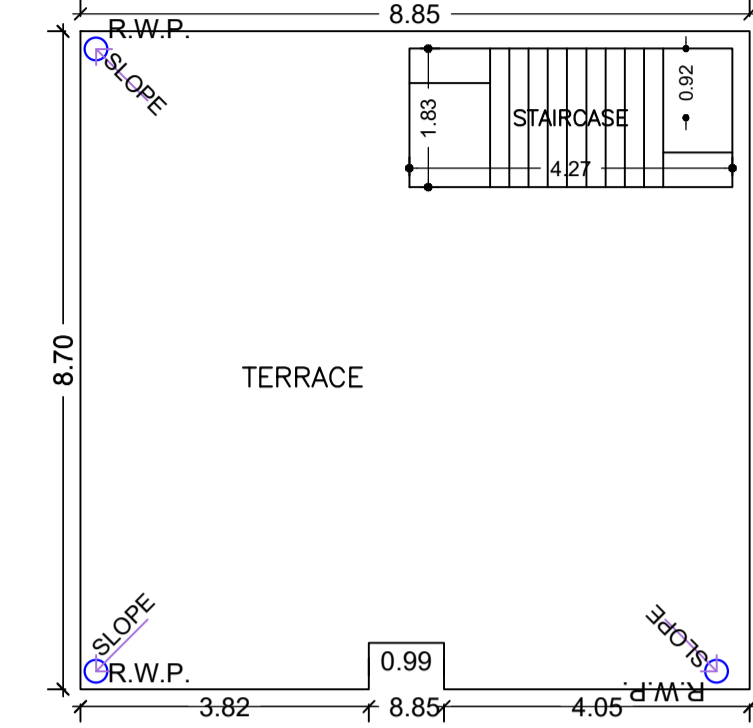

TERRACE FLOOR PLAN
(SCALE 1:100)

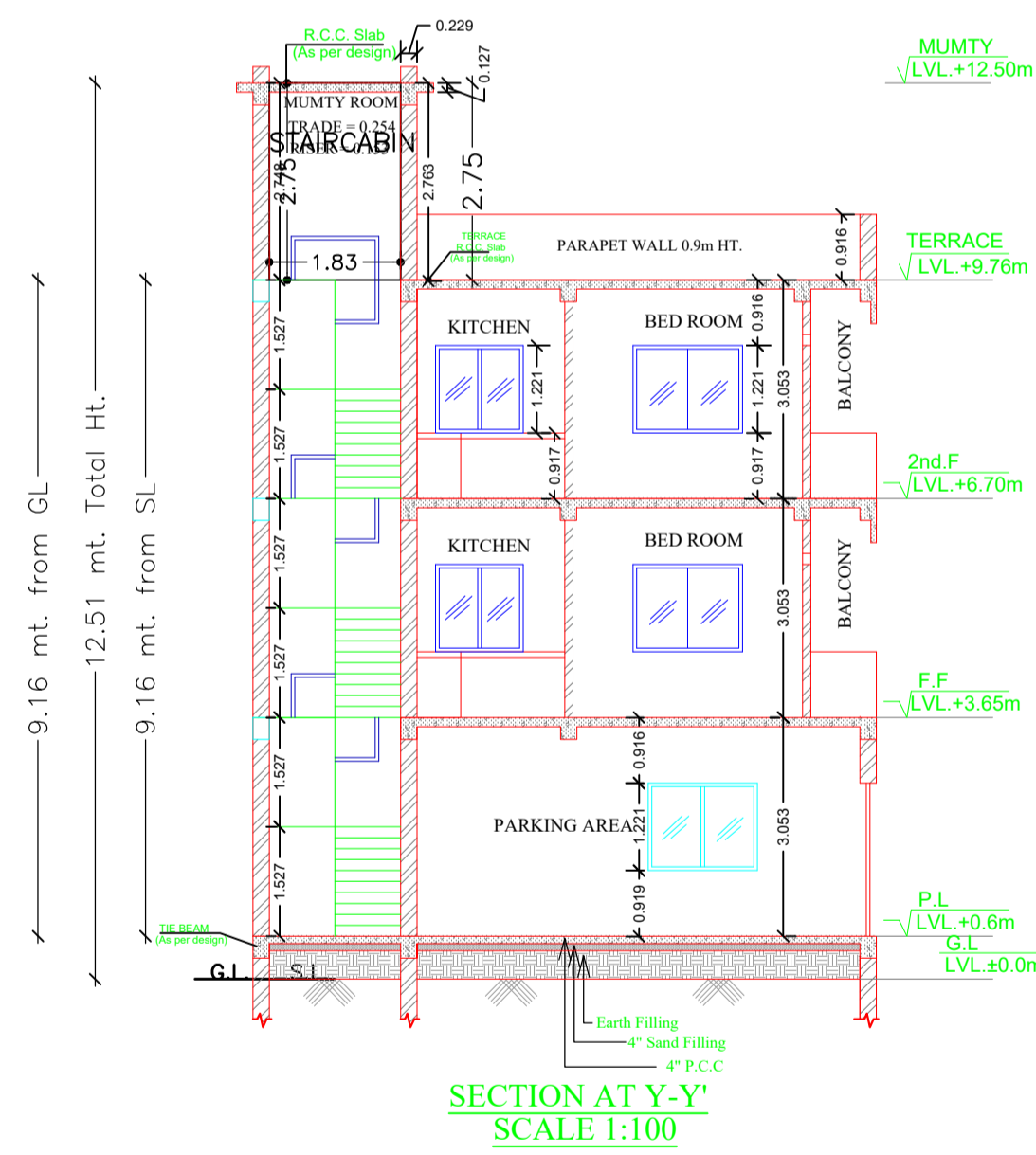

SECTION AT 'Y-Y'
SCALE 1:100

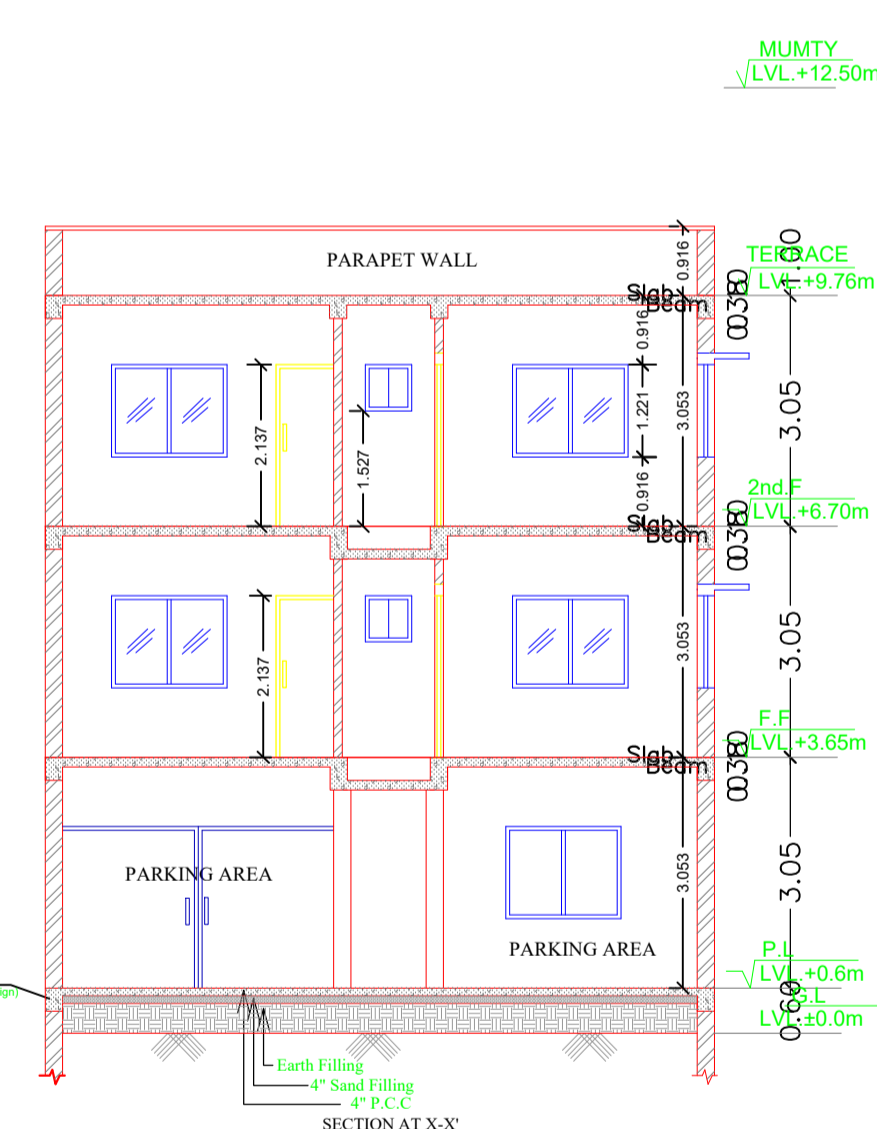

SECTION AT 'X-X'
SCALE 1:100

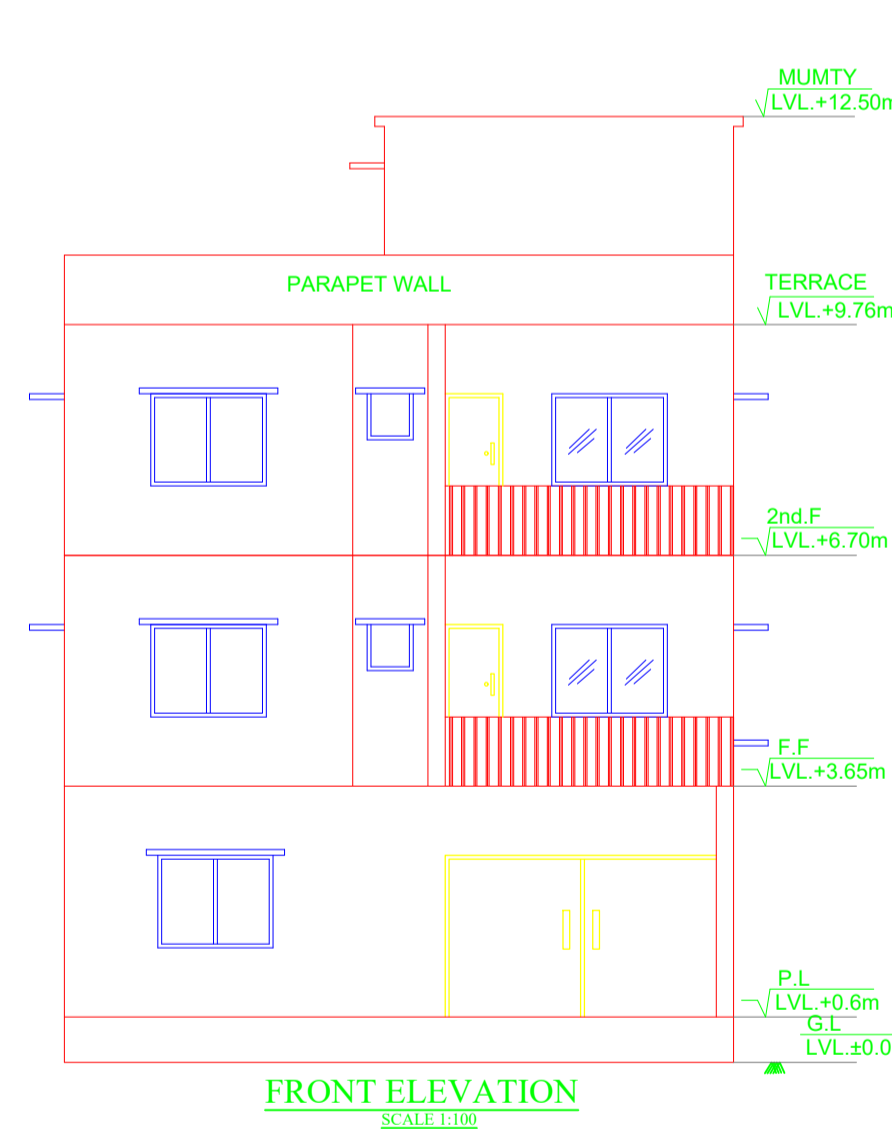

FRONT ELEVATION
SCALE 1:100

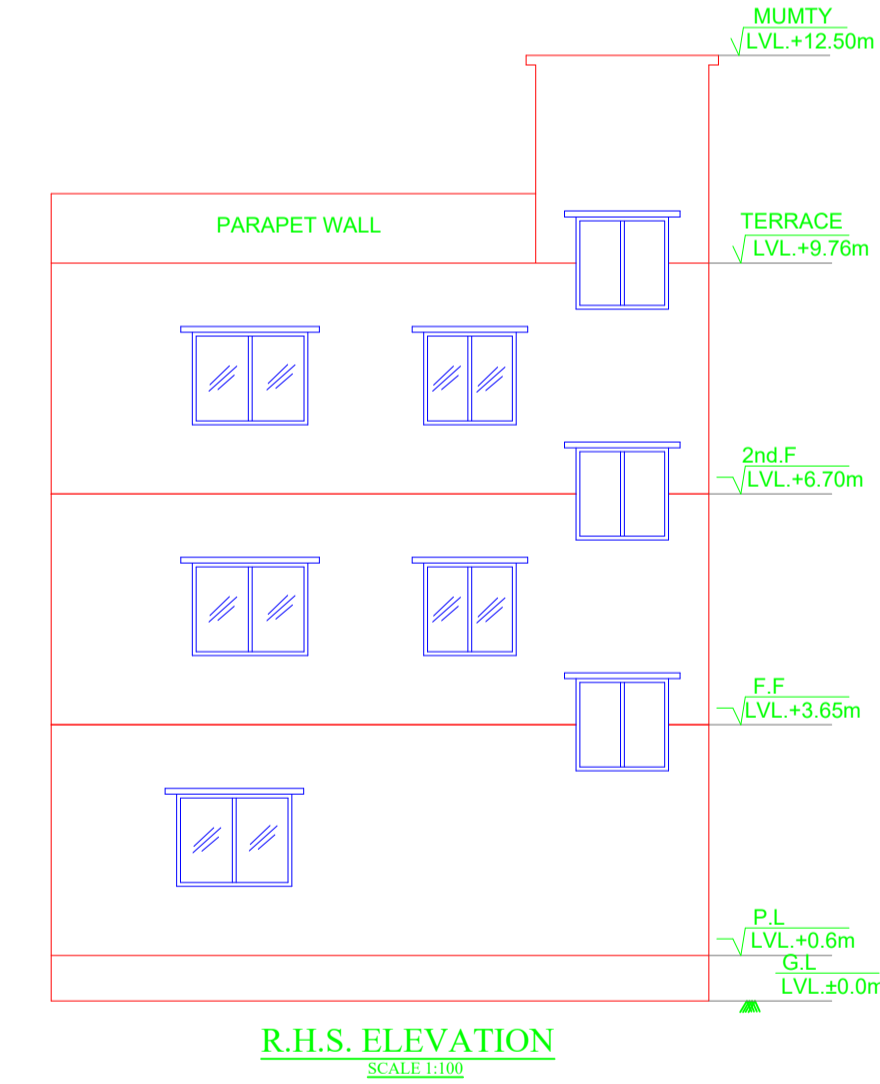

R.H.S. ELEVATION
SCALE 1:100

LTP NAME AND SIGNATURE	STRUCTURAL ENG'S NAME AND SIGNATURE	OWNER NAME AND SIGNATURE	REAL SIGNATURE
sm shahreyar MNAC/ARC/0026/2017			