

SITE PLAN

Building USE/SUBUSE Details

Building Name	Building Use	Building SubUse	Building Structure
A (RESIDENTIAL)	Residential	Residential Bldg/Apartment	Non-Highrise

Proposal Basic Information

Proposal File No.	MNAC/BP/0024/W10/2022
Owner Name	MRS. USHA YADAV
Khata No	276
Plot No	262
Village Name	Baliguma
Use	Residential
SubUse	Bungalow/ Dwelling / Non Apartment

FAR & Tenement Details (Table 4c-1)

Building	No. of Same Bldg	Total Built Up Area (Sq.mt.)	Deductions (Area in Sq.mt.)	Proposed FAR Area (Sq.mt.)	Total FAR Area (Sq.mt.)	Total Consumed Additional FAR Area (Sq.mt.)	Tnmt (No.)
A (RESIDENTIAL)	1	215.54	49.03	166.51	166.51	166.51	01
Grand Total :	1	215.54	49.03	166.51	166.51	166.51	01

AREA STATEMENT MANGO MUNICIPAL CORPORATION	VERSION NO.: 1.0.62	VERSION DATE: 16/10/2020
PROJECT DETAIL:	MUNICIPAL CORPORATION	
Region: JHARKHAND URBAN LOCAL BODIES	Plot Use: Residential	
District: EAST SINGHBHUM	Plot SubUse: Bungalow/ Dwelling / Non Apartment	
Authority: MANGO MUNICIPAL CORPORATION	PlotNearbyReligiousStructure: NA	
Inward_No: MNAC/BP/0024/W10/2022	Plot/SubPlot No: 262	
Application Type: General Proposal	North: Road Width - 5.48	
Project Type: Building Permission	South: Plot No. - 262	
Nature of Development: New	East: Road Width - 5.48	
Location of Development Area: Old Area	West: Plot No. - 262	
AREA DETAILS:	SQ.MT.	
AREA OF PLOT (Minimum)	(A)	178.72
Deduction for NetPlot Area		
Surrender Free of Cost	6.40	
Total	6.40	
NET AREA OF PLOT(Gross Plot Area - Deduction from Gross Plot area)	(A-Deductions)	172.32
Deduction for Balance Plot Area(from Gross Plot Area)		
Surrender Free of Cost	6.40	
Common Plot	26.94	
Total	33.34	
BALANCE AREA OF PLOT(Net Plot Area - Recreational/Amenity space)	(A-Deductions)	145.38
PLOT AREA FOR COVERAGE(Net Plot Area)	(A-Deductions)	172.32
Plot Area for FAR (Net Plot Area + RoadWidening Area)	(A-Deductions)	178.72
COVERAGE CHECK		
Permissible Coverage area (70.00 %)	120.62	
Proposed Coverage Area (62.54 %)	107.77	
Total Prop. Coverage Area (62.54 %)	107.77	
Balance coverage area (7.46 %)	12.85	
FAR CHECK		
Perm. FAR Area (1.80)	321.70	
Total Perm. FAR area	321.70	
Residential FAR	166.51	
Proposed FAR Area	166.51	
Total Proposed FAR Area	166.51	
Consumed FAR (Factor)	0.93	
Balance FAR Area	155.19	
BUILT UP AREA CHECK		
Total Proposed BuiltUp Area	215.54	
ARCHITECT (Regd)	Chandrika Sharma	
ENGINEER (Regd)		
SUPERVISOR (Regd)		
OWNER (Regd)	MRS. USHA YADAV	
DEVELOPMENT AUTHORITY	LOCAL BODY	

COLOR INDEX	
PLOT BOUNDARY	Black
ABUTTING ROAD	Green
PROPOSED CONSTRUCTION	Red
COMMON PLOT	Yellow
ROAD WIDENING AREA	Blue
EXISTING (To be retained)	Blue
EXISTING (To be demolished)	Yellow

Buildingwise Floor FAR Details

Floor Name	Building Name		Total	
	Proposed Built Up Area (Sq.mt.)	Proposed FAR Area (Sq.mt.)	Total Proposed Built Up Area (Sq.mt.)	Total FAR Area (Sq.mt.)
Ground Floor	107.77	58.74	107.77	58.74
First Floor	107.77	107.77	107.77	107.77
Terrace Floor	0.00	0.00	0.00	0.00
Total :	215.54	166.51	215.54	166.51

LTP NAME AND SIGNATURE	STRUCTURAL ENG'S NAME AND SIGNATURE	DESIGNER NAME AND SIGNATURE	PREPARED SIGNATURE
Chandrika Sharma MNAC/DFTMN/0017/2017			

Proposal Basic Information	
Proposal File No	MNAC/BP/0024/W10/2022
Owner Name	MRS. USHA YADAV
Khata No	276
Plot No	262
Village Name	Baliguma
Use	Residential
SubUse	Bungalow/ Dwelling / Non Apartment

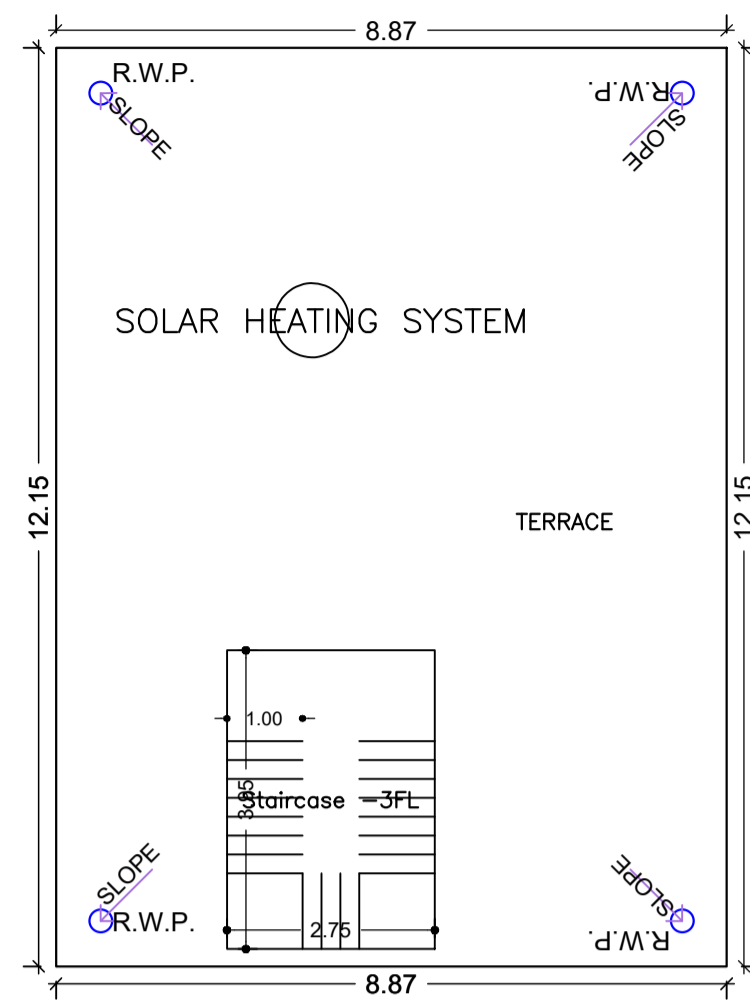
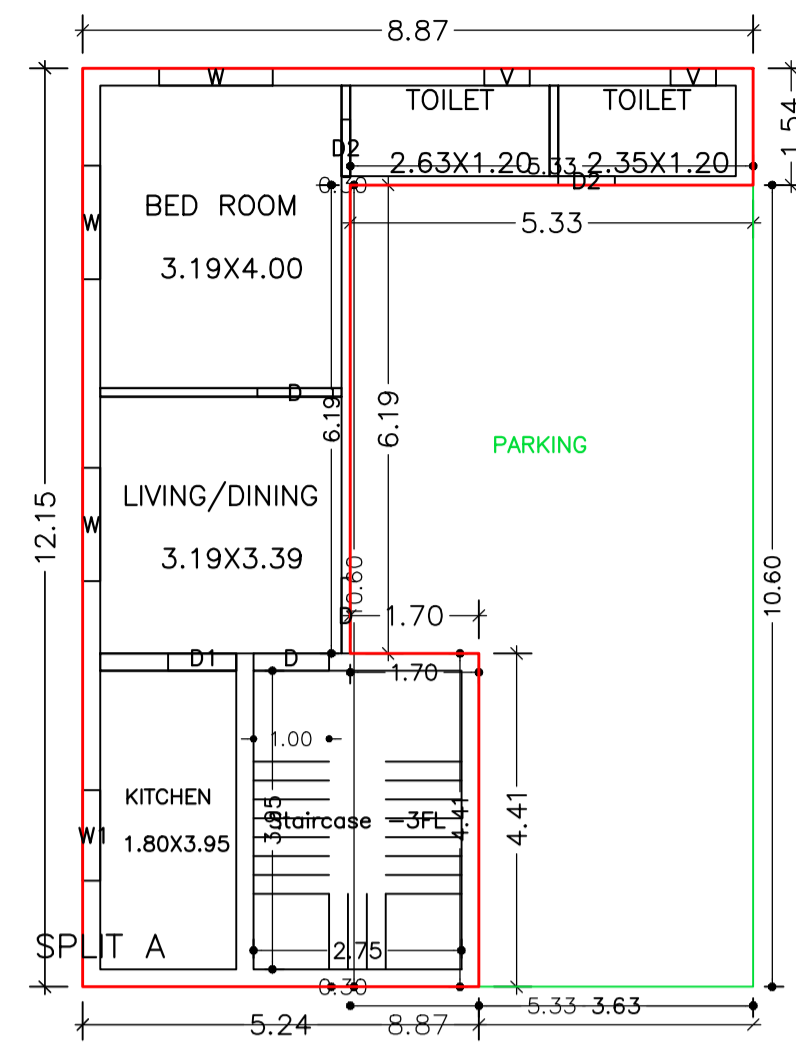

TERRACE FLOOR PLAN (SCALE 1:100)

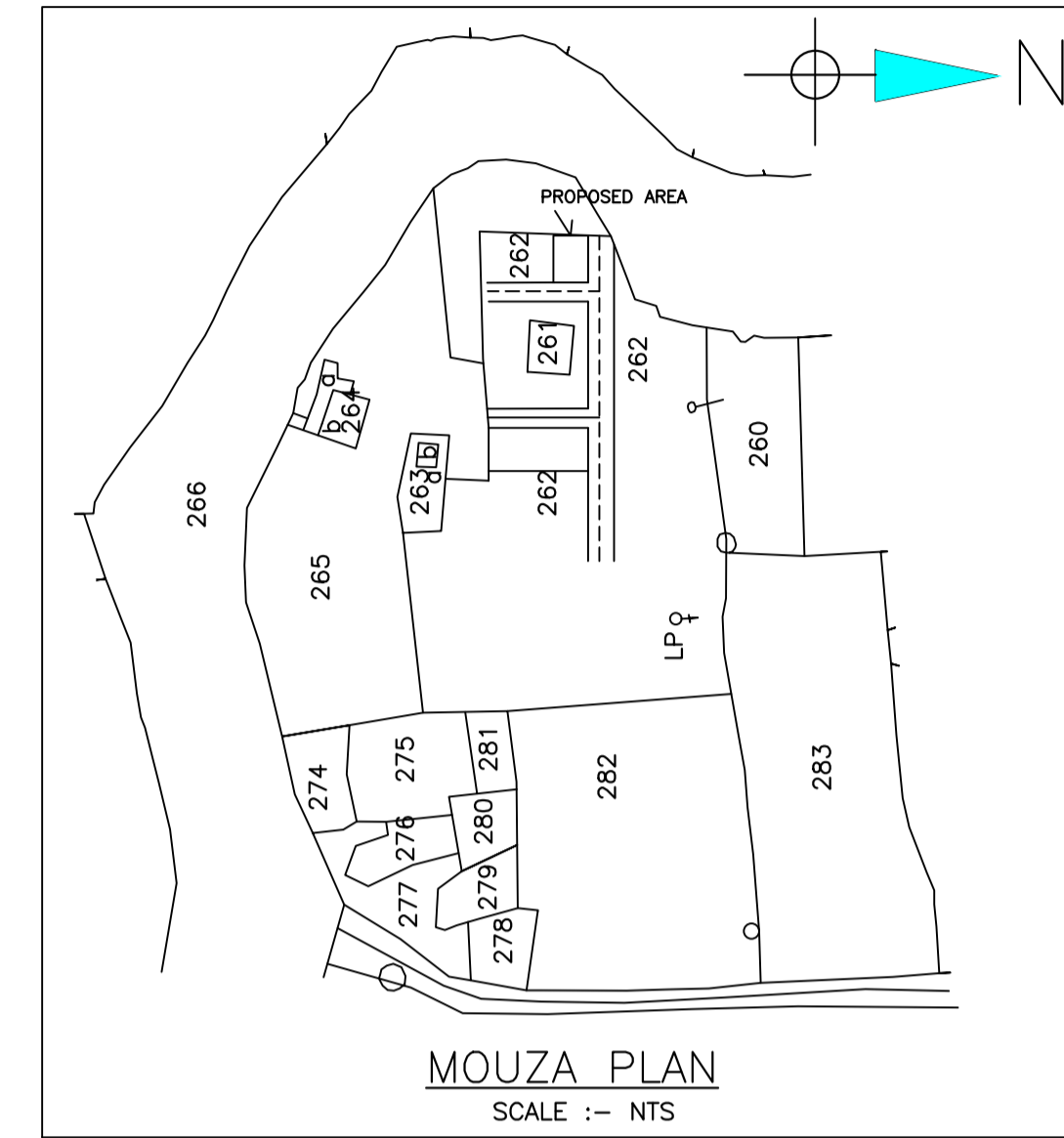

MOUZA PLAN (SCALE :- NTS)

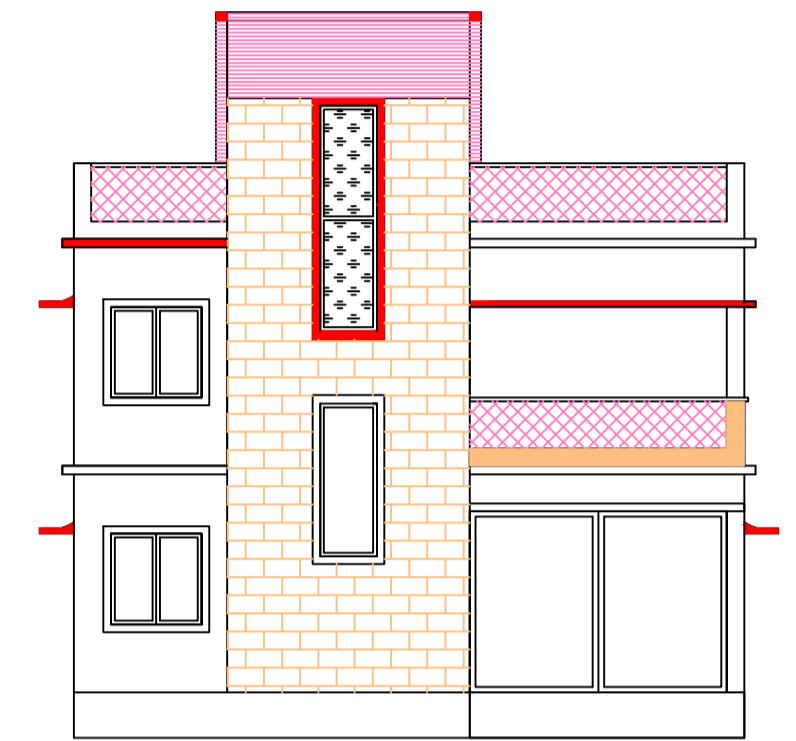

FRONT ELEVATION (SCALE 1:100)

GROUND FLOOR PLAN (Proposed) (SCALE 1:100)

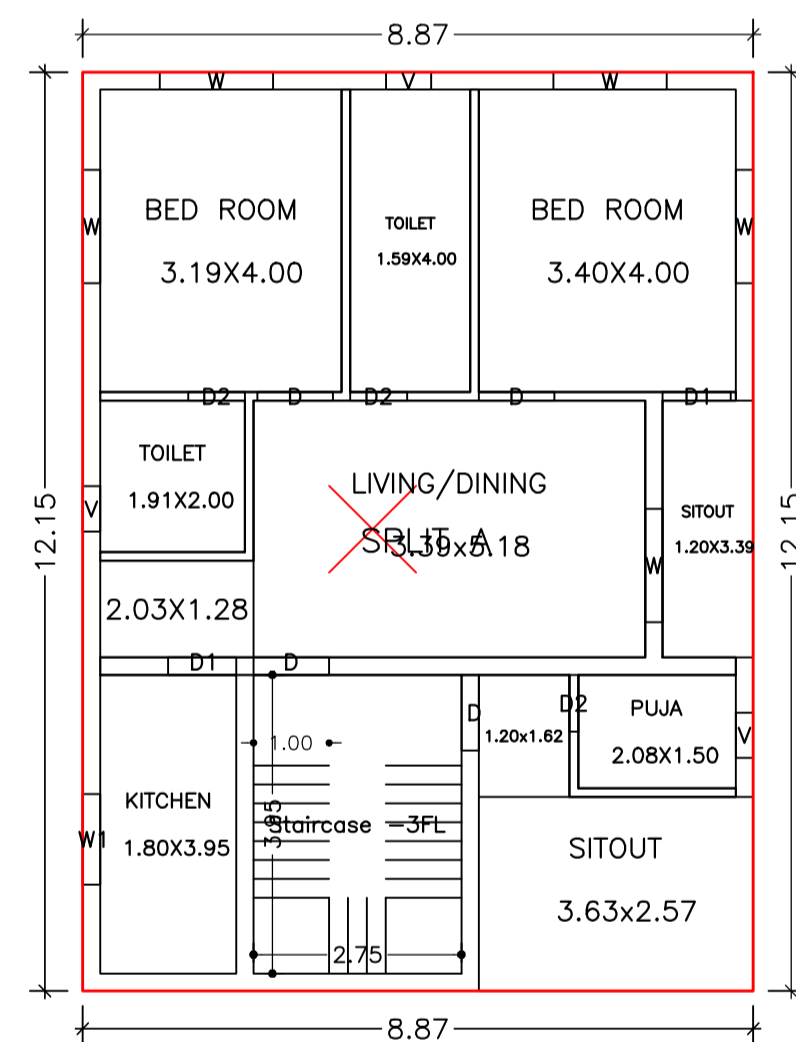

FIRST FLOOR PLAN (Proposed) (SCALE 1:100)

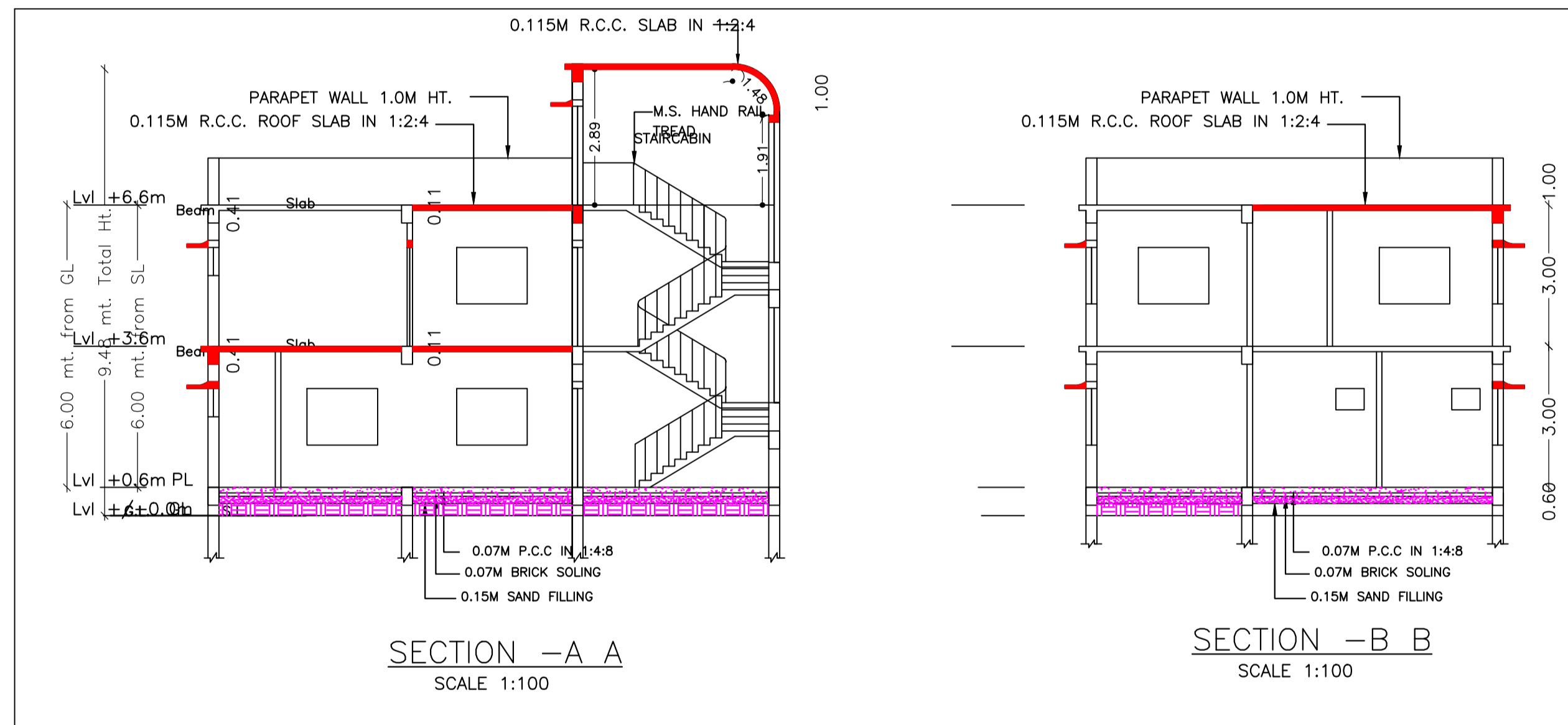
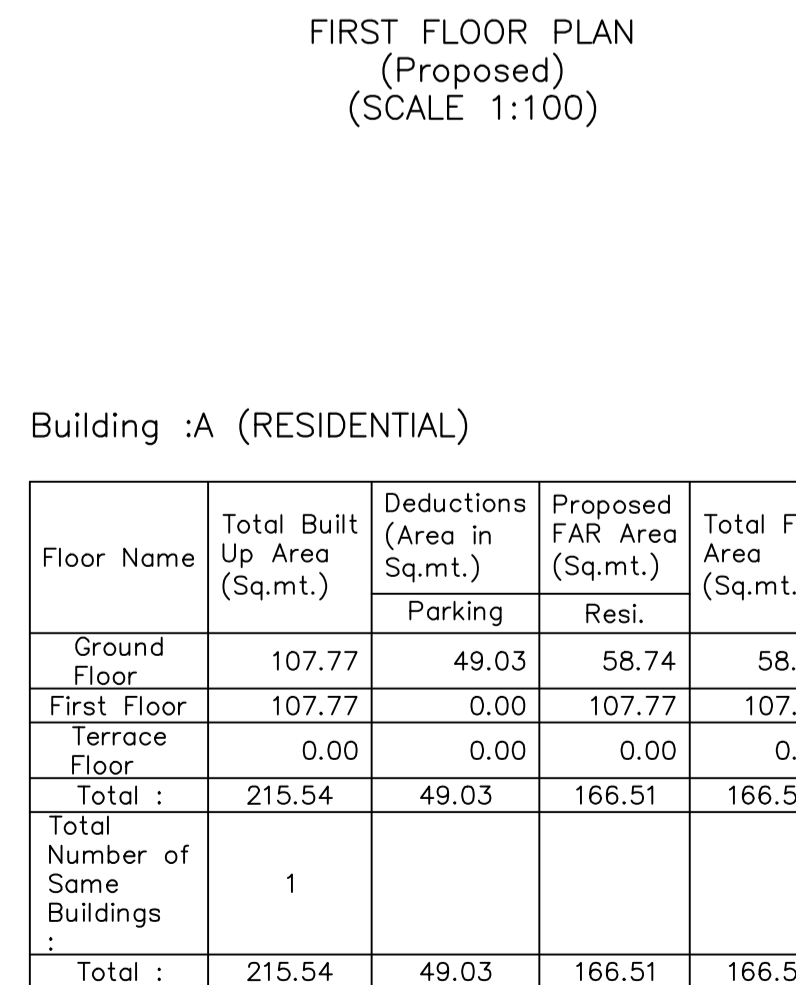

SECTION -A A (SCALE 1:100)

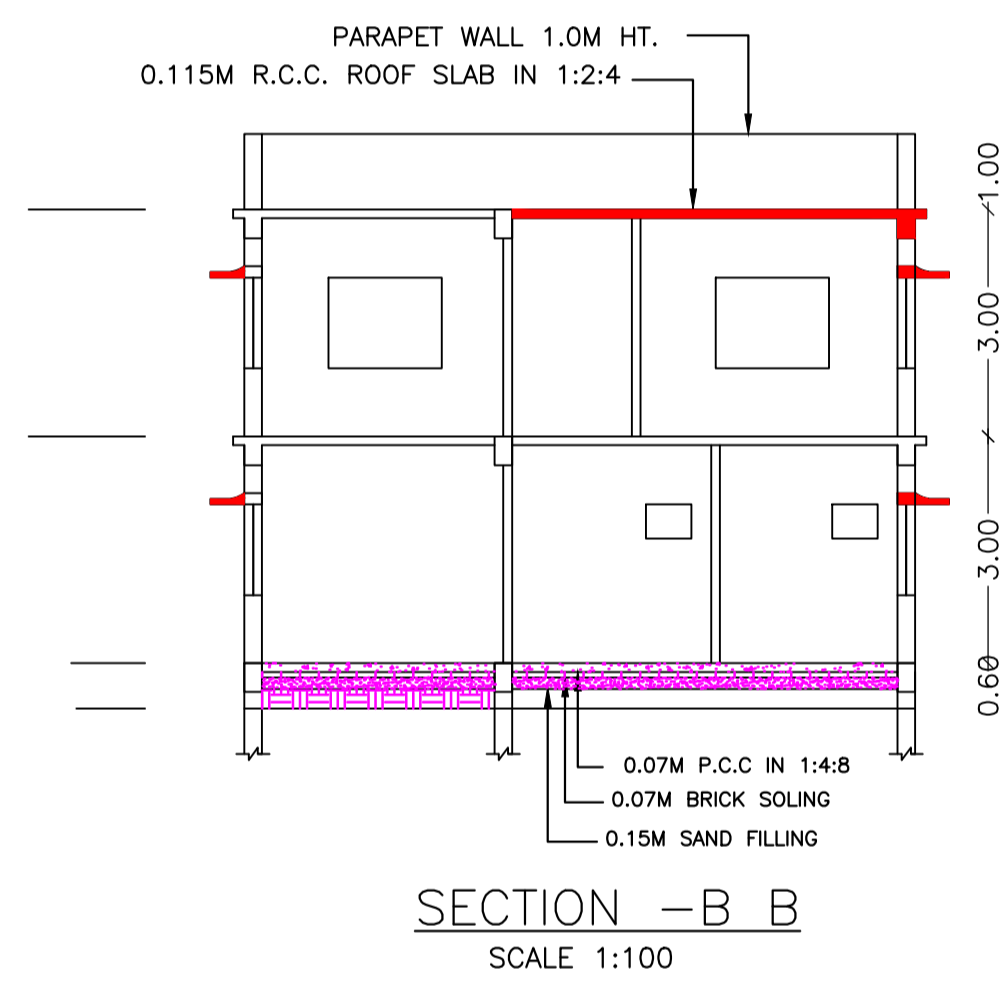

SECTION -B B (SCALE 1:100)

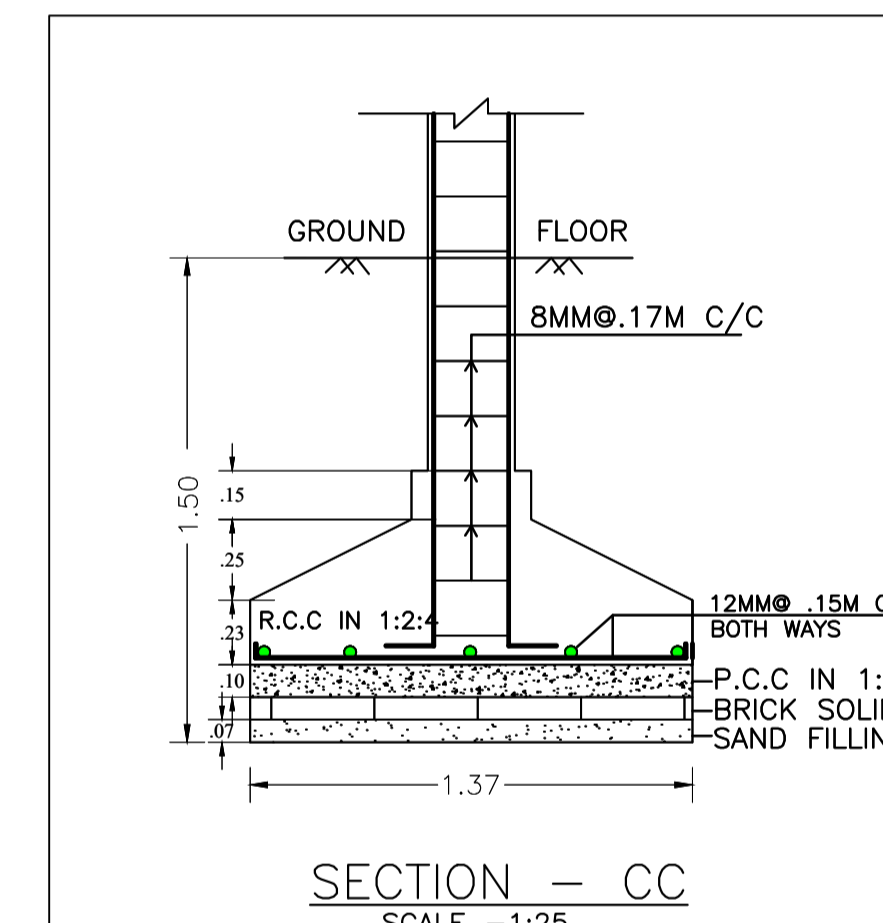

SECTION -C C (SCALE -1:25)

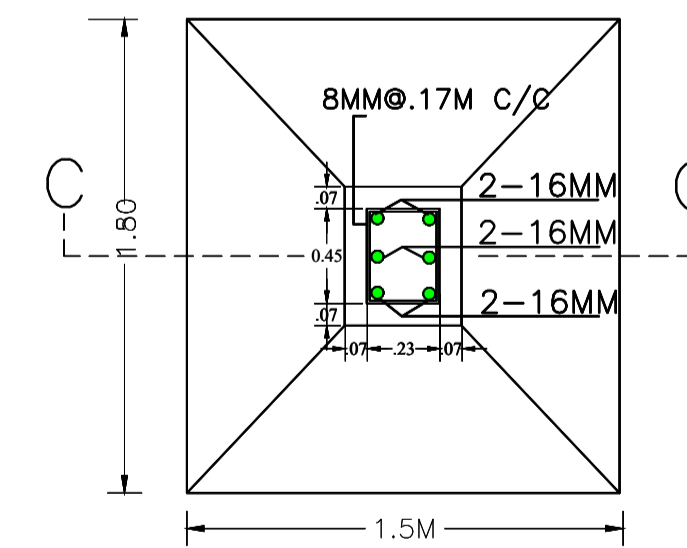

R.C.C. COL. FDN. PLAN (SCALE -1:25)

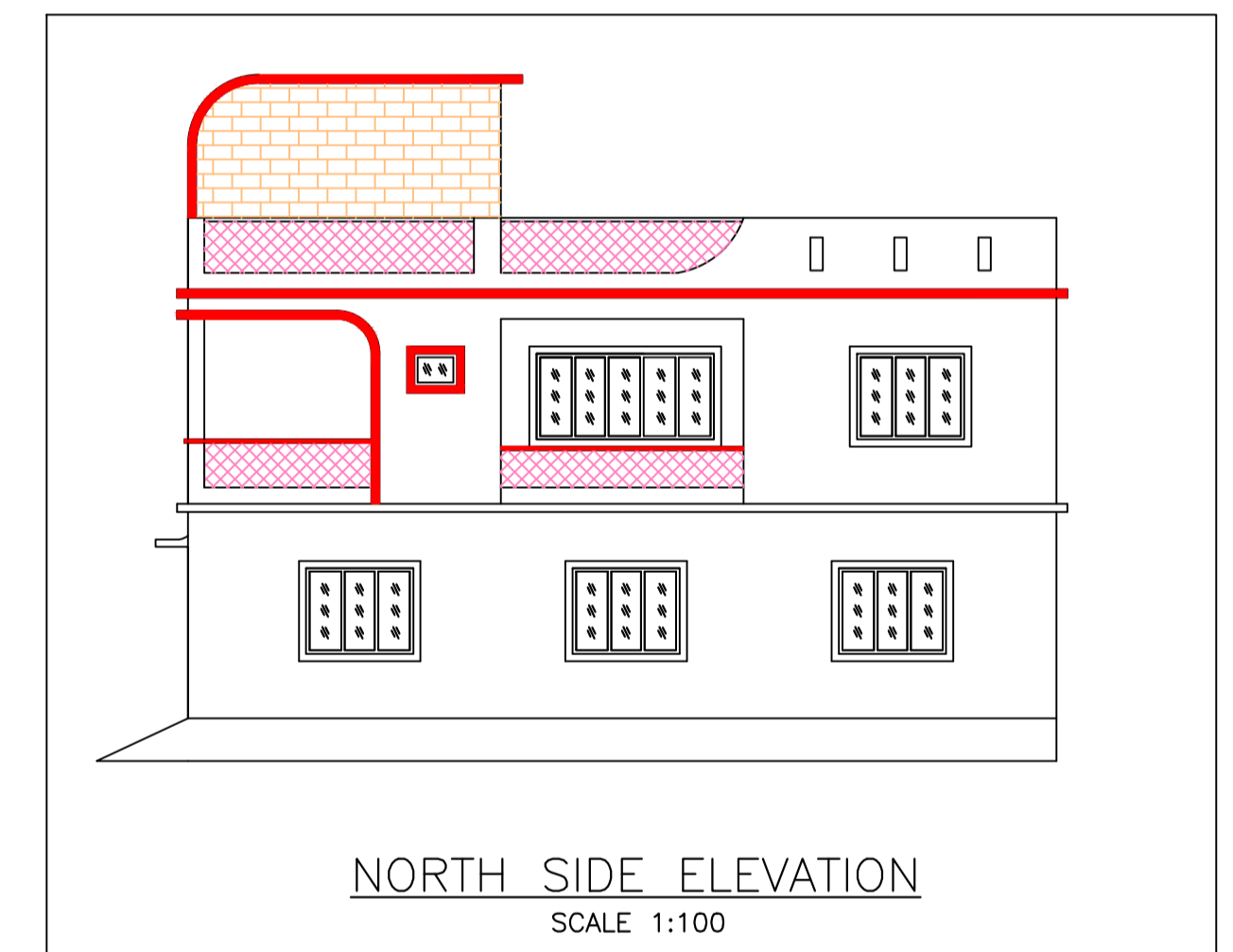

NORTH SIDE ELEVATION (SCALE 1:100)

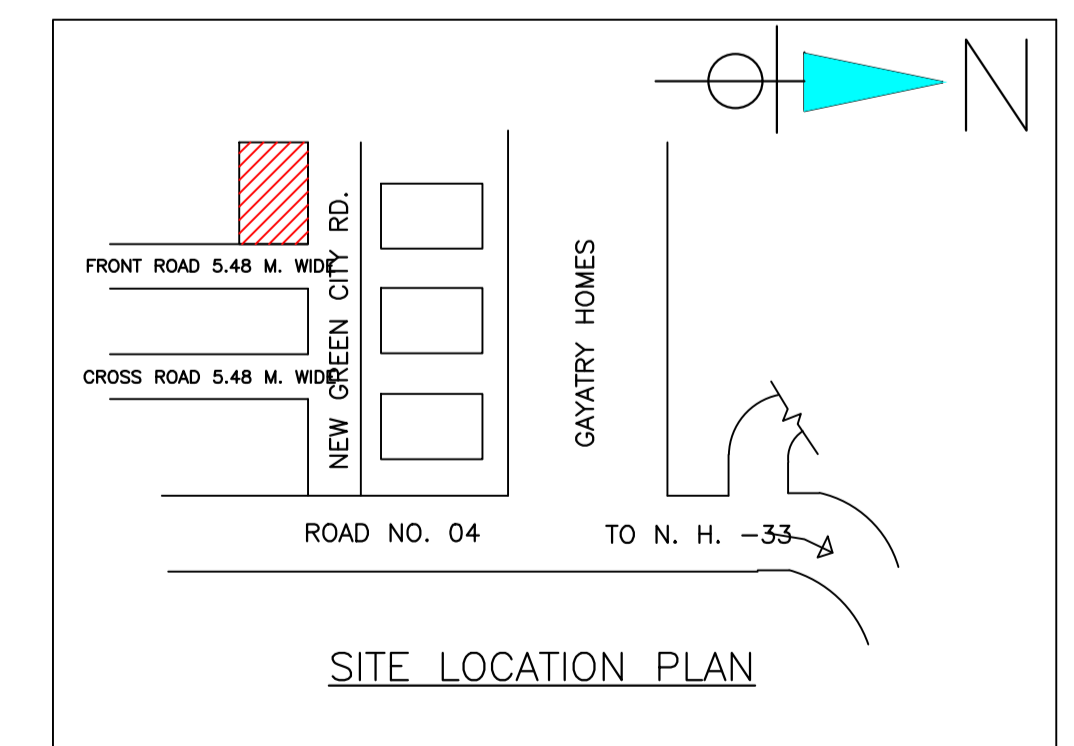

SITE LOCATION PLAN

Building :A (RESIDENTIAL)

Floor Name	Total Built Up Area (Sq.mt.)	Deductions (Area in Sq.mt.)	Proposed FAR Area (Sq.mt.)	Total FAR Area (Sq.mt.)	Total Consumed Additional FAR Area (Sq.mt.)	Tnmt (No.)
Ground Floor	107.77	49.03	58.74	58.74	58.74	01
First Floor	107.77	0.00	107.77	107.77	107.77	00
Terrace Floor	0.00	0.00	0.00	0.00	0.00	00
Total :	215.54	49.03	166.51	166.51	166.51	01
Total Number of Same Buildings :	1					
Total :	215.54	49.03	166.51	166.51	166.51	01

SCHEDULE OF DOOR:

BUILDING NAME	NAME	LENGTH	HEIGHT	NOS
A (RESIDENTIAL)	D2	0.75	2.10	05
A (RESIDENTIAL)	D1	0.90	2.10	03
A (RESIDENTIAL)	D	1.00	2.10	07

SCHEDULE OF WINDOW/VENTILATION:

BUILDING NAME	NAME	LENGTH	HEIGHT	NOS
A (RESIDENTIAL)	V	0.60	0.90	05
A (RESIDENTIAL)	W1	1.20	1.20	02
A (RESIDENTIAL)	W	1.50	1.20	08

UnitBUA Table for Building :A (RESIDENTIAL)

FLOOR	Name	UnitBUA Type	UnitBUA Area	Carpet Area	No. of Rooms	No. of Tenement
GROUND FLOOR PLAN	SPLIT A	FLAT	125.56	119.01	5	1
FIRST FLOOR PLAN	SPLIT A	FLAT	0.00	0.00	9	0
Total:	-	-	125.56	119.01	14	1

LTP NAME AND SIGNATURE Chandrika Sharma MNAC/DFTMN/0017/2017	STRUCTURAL ENG'S NAME AND SIGNATURE	SUBVENER NAME AND SIGNATURE	AUDITOR'S NAME AND SIGNATURE
--	-------------------------------------	-----------------------------	------------------------------

Proposal Basic Information	
Proposal File No	MNAC/BP/0024/W10/2022
Owner Name	MRS. USHA YADAV
Khata No	276
Plot No	262
Village Name	Baliguma
Use	Residential
SubUse	Bungalow/ Dwelling / Non Apartment

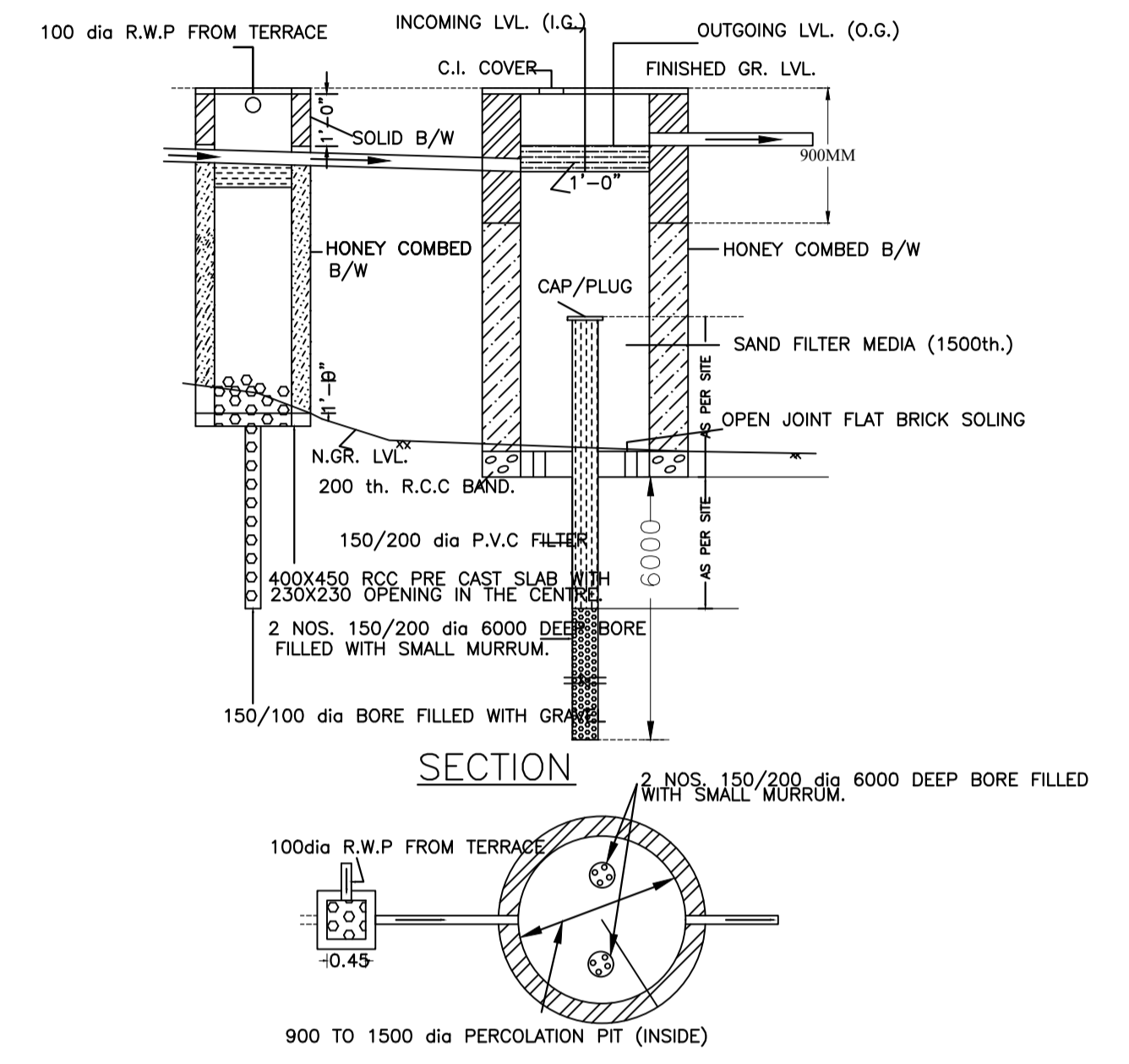

WATER HARVESTING PLAN (NTS)

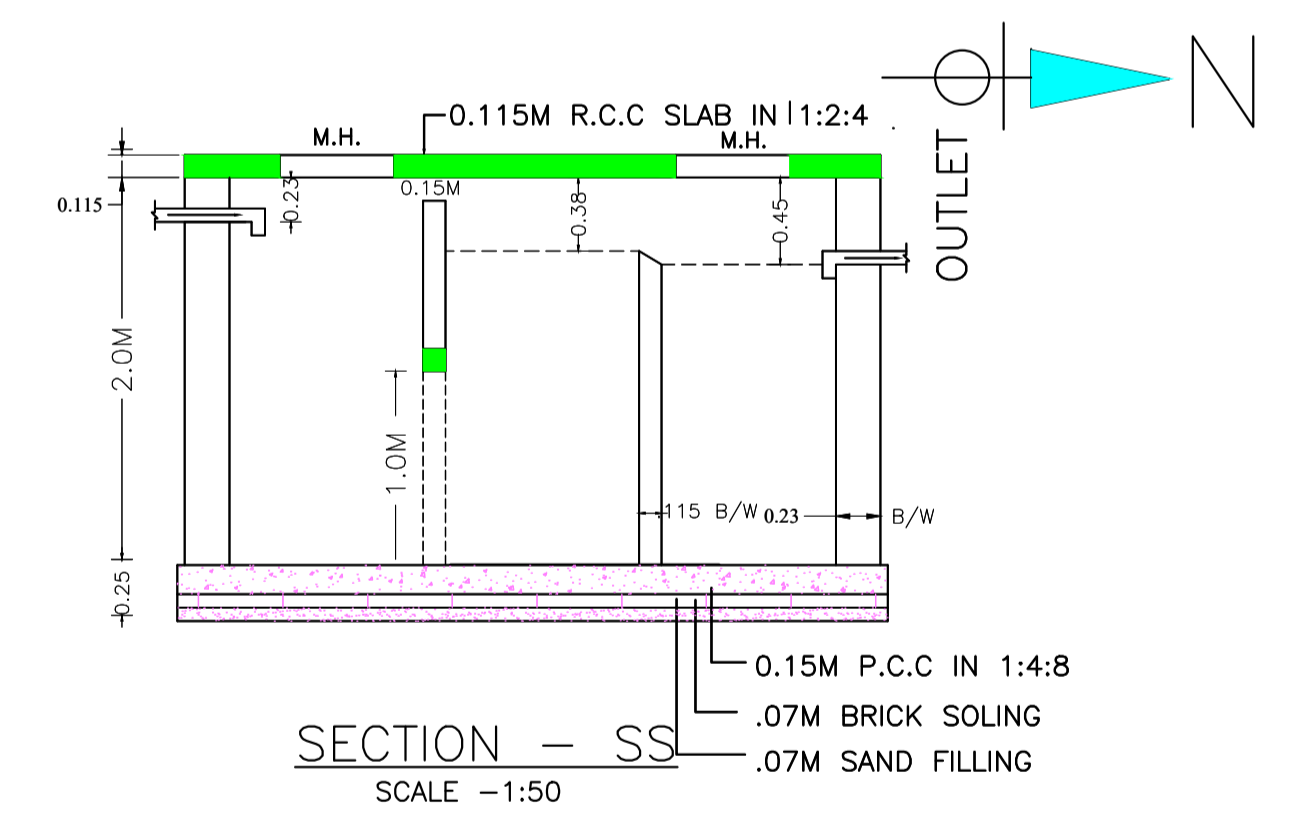

SEPTIC TANK PLAN

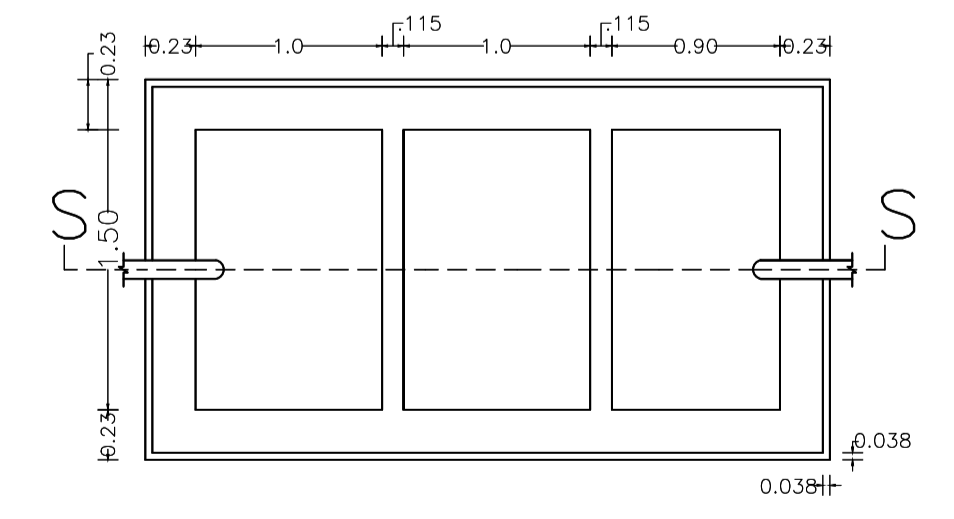

LTP NAME AND SIGNATURE	STRUCTURAL ENG'S NAME AND SIGNATURE	DESIGNER NAME AND SIGNATURE	AUTHOR NAME AND SIGNATURE
Chandrika Sharma MNAC/DFTMN/0017/2017			