

SITE - PLAN
SCALE 1:100

SITE PLAN

FAR & Tenement Details (Table 4c-1)

Building	No. of Same Bldg	Gross Built Up Area (Sq.mt.)	Deductions From Gross BUA(Area in Sq.mt.)	Total Built Up Area (Sq.mt.)	Deductions (Area in Sq.mt.)		Proposed FAR Area (Sq.mt.)	Add Area In FAR (Sq.mt.)	Total FAR Area (Sq.mt.)	Total Consumed Additional FAR Area (Sq.mt.)	Tnmt (No.)
					Cutout	Lift Parking Resi. Stair					
A (RESIDENTIAL)	1	655.06	13.17	641.89	12.92	101.13	503.30	9.19	512.49	512.49	01
Grand Total	1	655.06	13.17	641.89	12.92	101.13	503.30	9.19	512.49	512.49	01

Proposal Basic Information

Proposal File No.	MNAC/SP/0042/W09/2022
Owner Name	MRS VIBHA OJHA
Khata No	440
Plot No	1849
Village Name	Dimna
Use	Residential
SubUse	Bungalow/ Dwelling / Non Apartment

AREA STATEMENT MANGO MUNICIPAL CORPORATION	VERSION NO: 1.0.64
	VERSION DATE: 16/10/2020
PROJECT DETAIL:	
Region: JHARKHAND URBAN LOCAL BODIES	Plot Use: Residential
District: EAST SINGHBHUM	Plot SubUse: Bungalow/ Dwelling / Non Apartment
Authority: MANGO MUNICIPAL CORPORATION	PlotNearbyReligiousStructure: NA
Inward No: MNAC/SP/0042/W09/2022	PlotSubPlot No: 1849
Application Type: General Proposal	North: Road Width - 13.1
Project Type: Building Permission	South: -
Nature of Development: New	East: -
Location of Development Area: Old Area	West: -
AREA DETAILS:	
AREA OF PLOT (Minimum)	(A) 240.42
NET AREA OF PLOT(Gross Plot Area - Deduction from Gross Plot area)	(A-Deductions) 240.42
Deduction for Balance Plot Area(from Gross Plot Area)	
Common Plot	19.16
Total	19.16
BALANCE AREA OF PLOT(Net Plot Area - Recreational/Amenity space)	(A-Deductions) 221.27
PLOT AREA FOR COVERAGE(Net Plot Area)	(A-Deductions) 240.42
Plot Area for FAR (Net Plot Area + Road Widening Area)	(A-Deductions) 240.42
COVERAGE CHECK	
Permissible Coverage area (60.00 %)	144.25
Proposed Coverage Area (48.14 %)	115.73
Total Prop. Coverage Area (48.14 %)	115.73
Balance coverage area (11.86 %)	28.52
FAR CHECK	
Perm. FAR Area (2.500)	601.05
Total Perm. FAR area	601.05
Residential FAR	503.31
Proposed FAR Area	512.50
Total Proposed FAR Area	512.50
Consumed FAR (Factor)	2.13
Balance FAR Area	88.55
BUILT UP AREA CHECK	
Total Proposed BuiltUp Area	641.89
ARCHITECT (Regd)	EJAZ AHMAD
ENGINEER (Regd)	
SUPERVISOR (Regd)	
OWNER (Regd)	MRS VIBHA OJHA
DEVELOPMENT AUTHORITY	LOCAL BODY

COLOR INDEX	
PLOT BOUNDARY	Black
ABUTTING ROAD	Green
PROPOSED CONSTRUCTION	Red
COMMON PLOT	Yellow
ROAD WIDENING AREA	Light Yellow
EXISTING (To be retained)	Blue
EXISTING (To be demolished)	Light Blue

Buildingwise Floor FAR Details

Floor Name	Building Name A (RESIDENTIAL)		Total	
	Proposed Built Up Area (Sq.mt.)	Proposed FAR Area (Sq.mt.)	Total Proposed Built Up Area (Sq.mt.)	Total FAR Area (Sq.mt.)
Basement Floor	128.90	9.19	128.90	9.19
Ground Floor	115.73	115.73	115.73	115.73
First Floor	132.42	129.19	132.42	129.19
Second Floor	132.42	129.19	132.42	129.19
Third Floor	132.42	129.19	132.42	129.19
Terrace Floor	0.00	0.00	0.00	0.00
Total	641.89	512.49	641.89	512.49

Building USE/SUBUSE Details

Building Name	Building Use	Building SubUse	Building Structure
A (RESIDENTIAL)	Residential	Bungalow/ Dwelling / Non Apartment	Non-Highrise

LTP NAME AND SIGNATURE	STRUCTURAL ENG'S NAME AND SIGNATURE	BUILDER NAME AND SIGNATURE	DIGITAL SIGNATURE
EJAZ AHMAD MNAC/DFTMN/0008/2020			

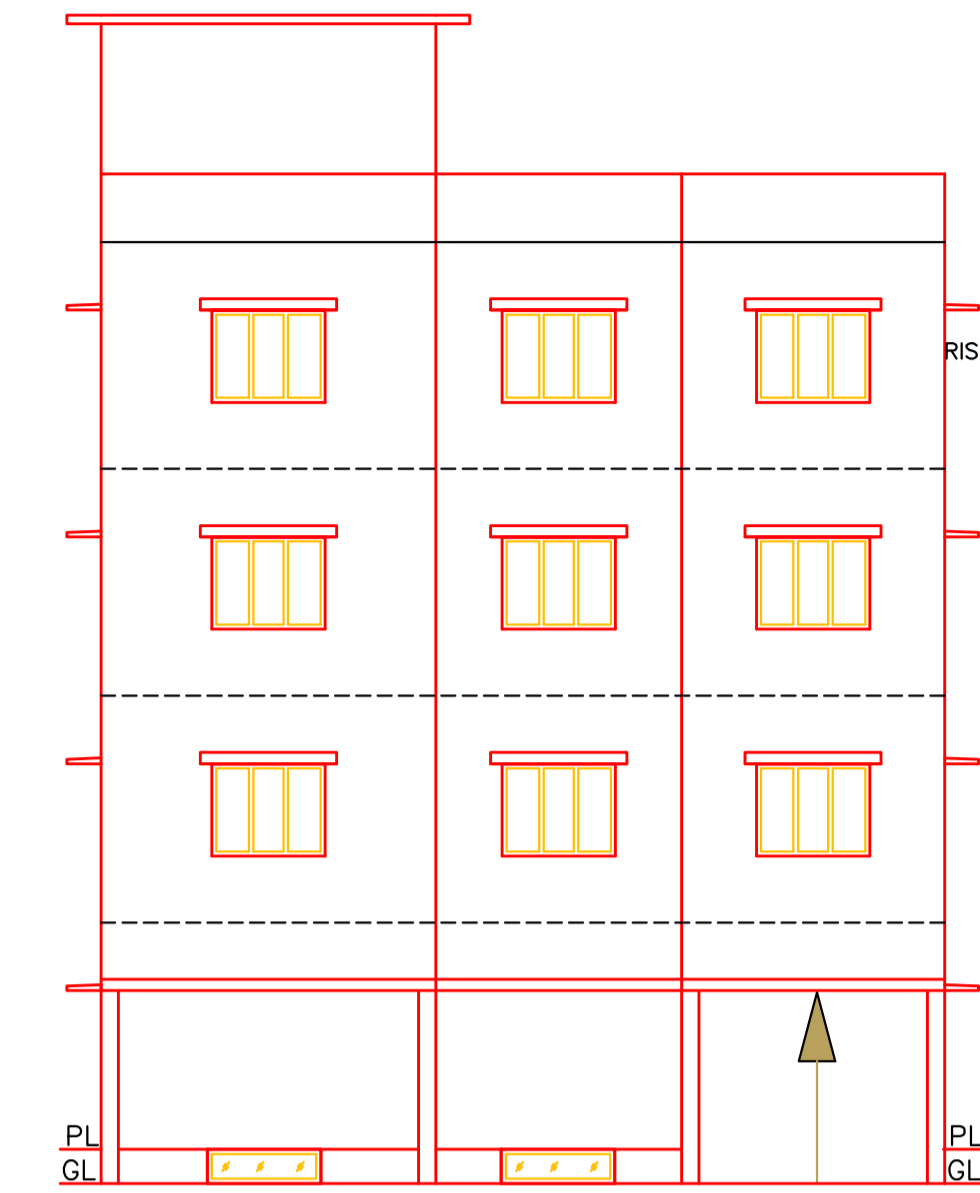
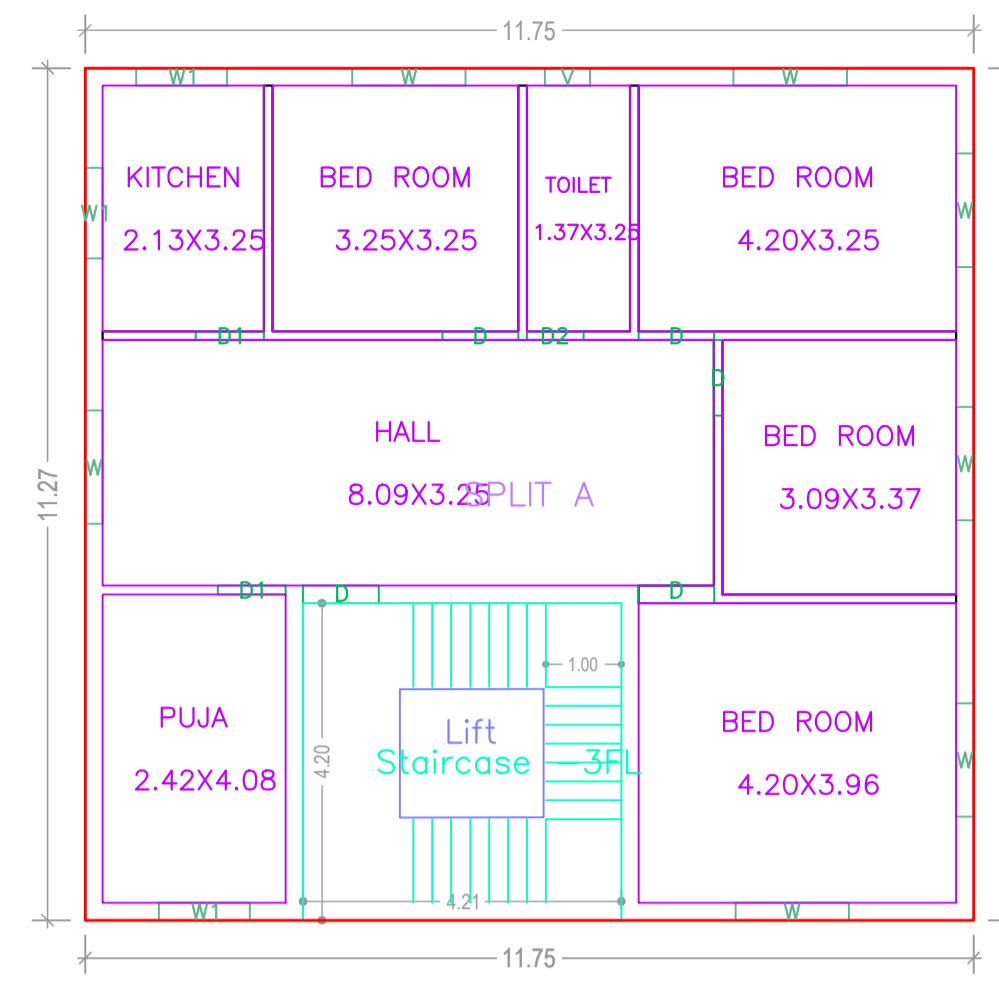
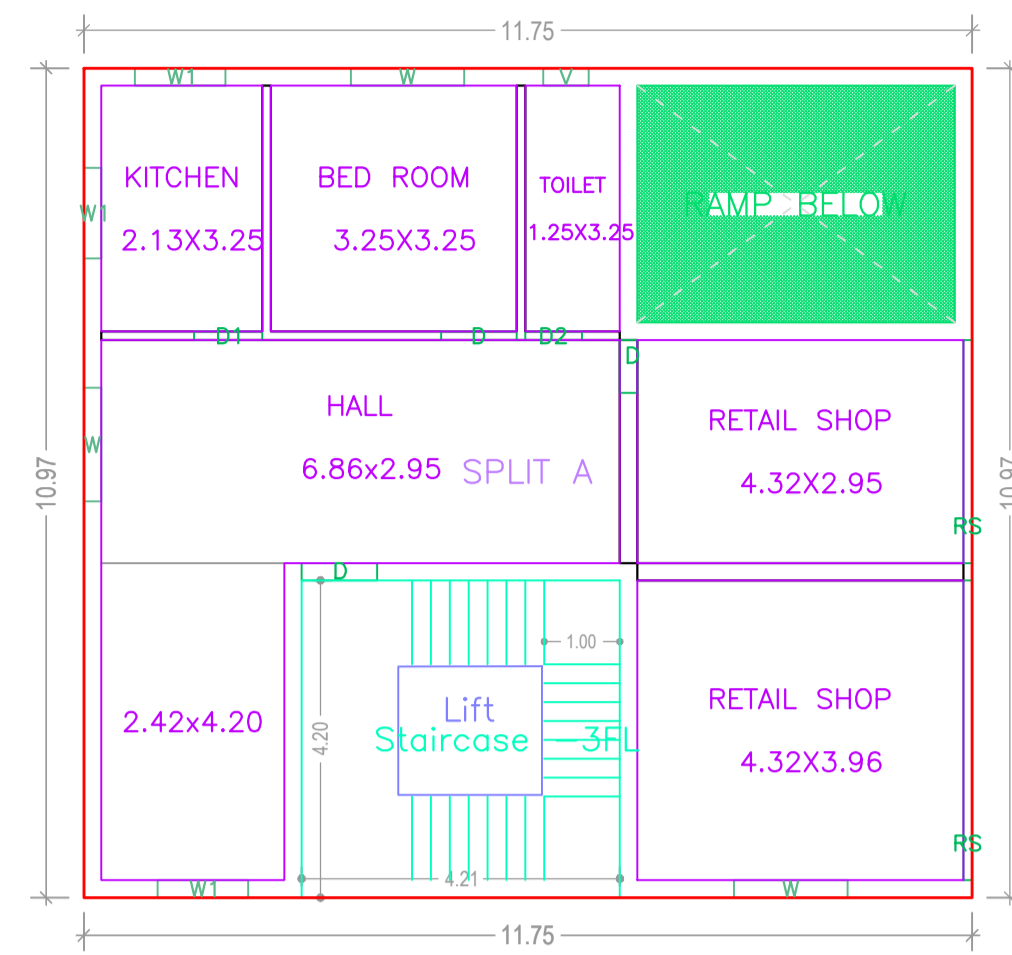
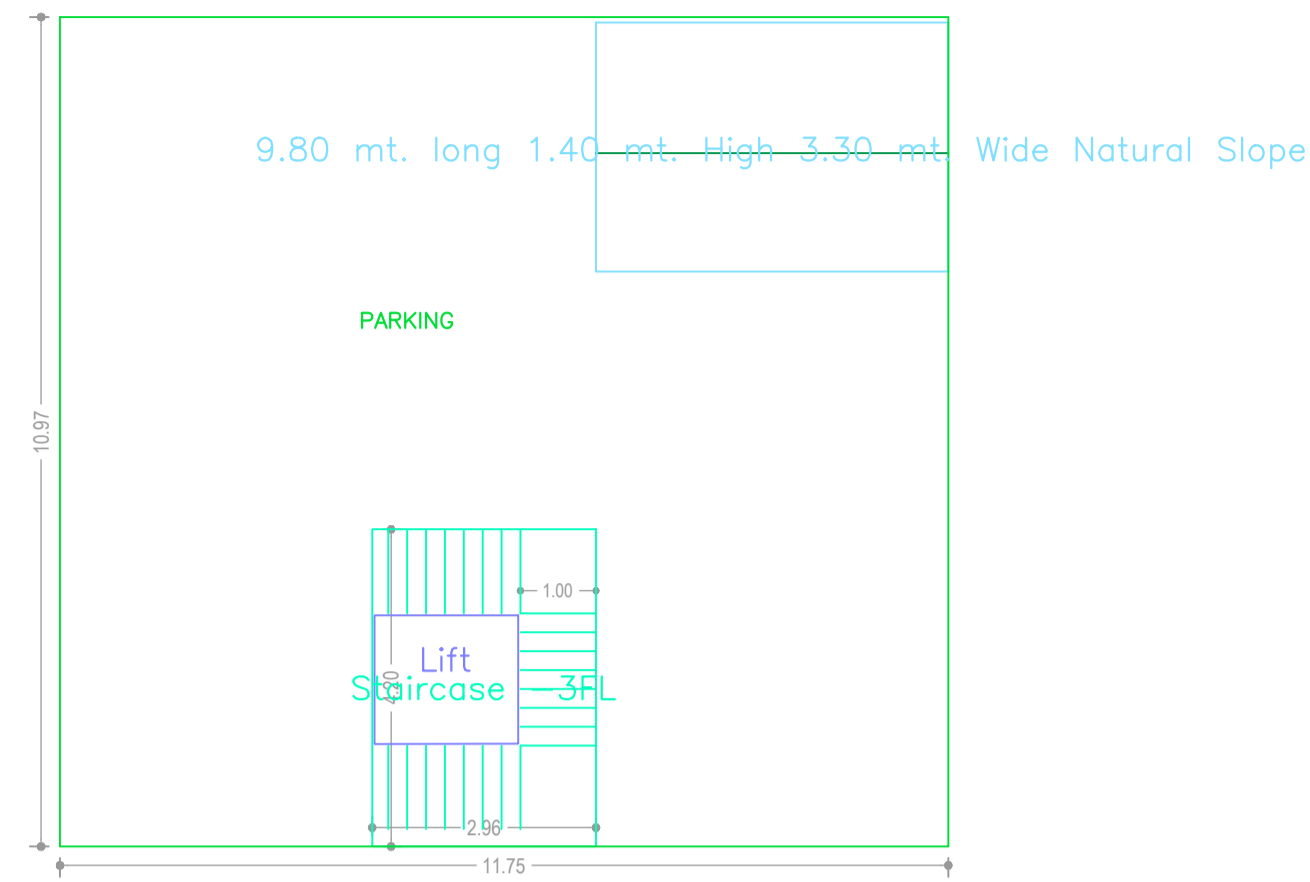

TYPICAL - 1- 3 FLOOR PLAN
(Proposed)
(SCALE 1:100)

BASEMENT FLOOR PLAN
(SCALE 1:100)

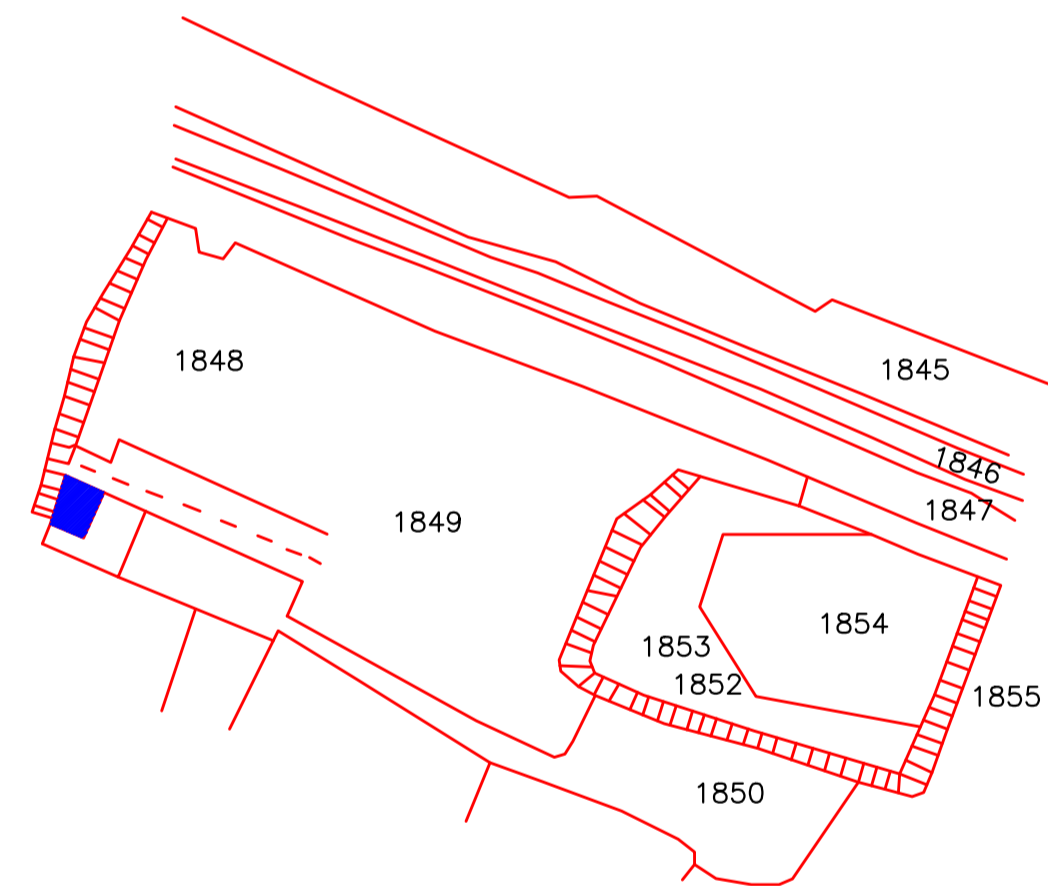

GROUND FLOOR PLAN
(Proposed)
(SCALE 1:100)

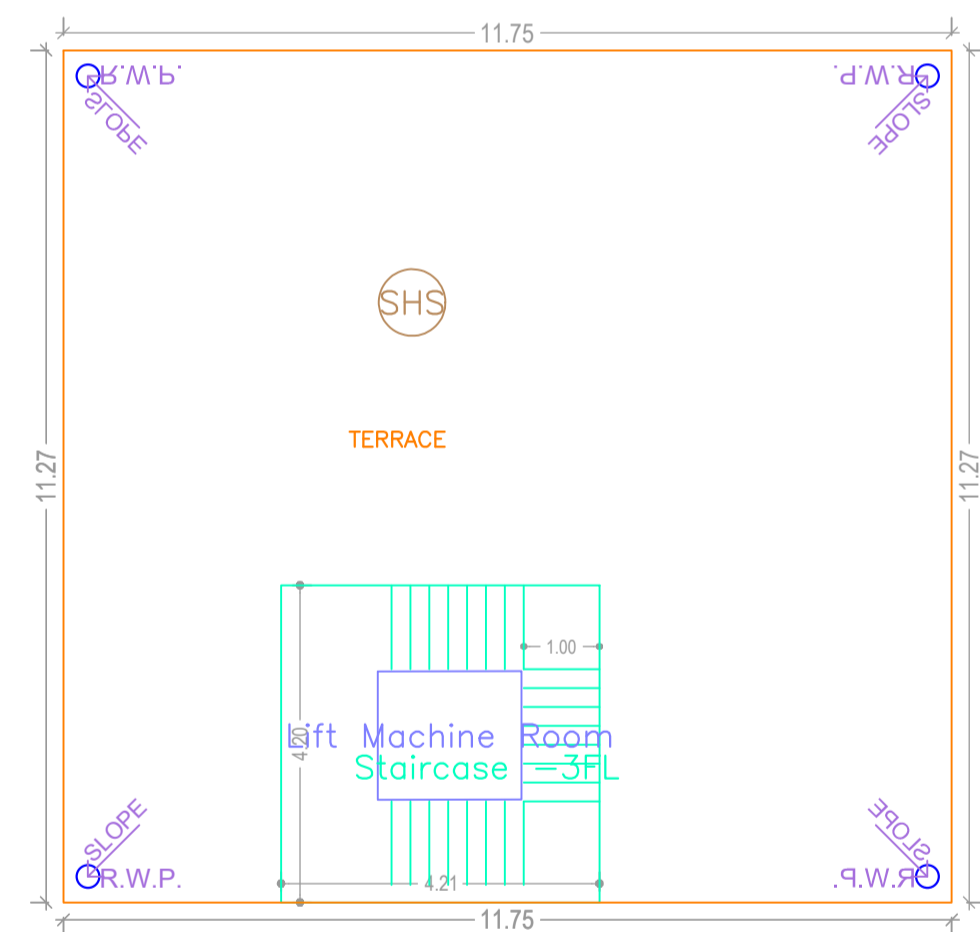

TERRACE FLOOR PLAN
(SCALE 1:100)

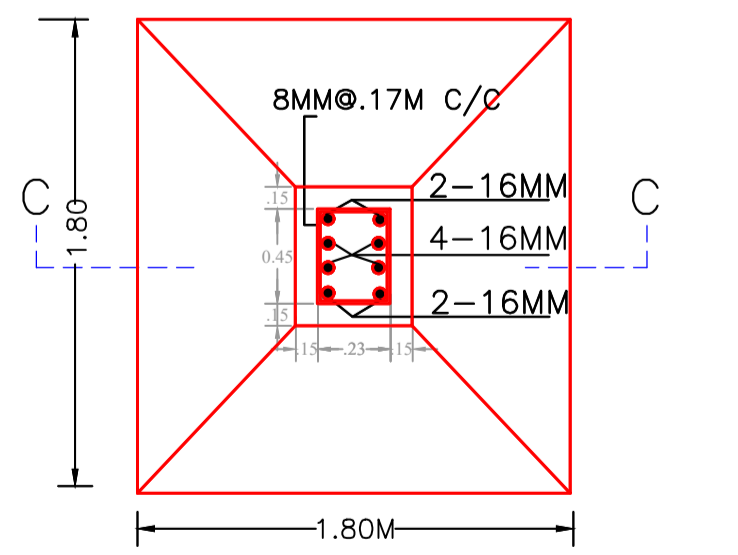
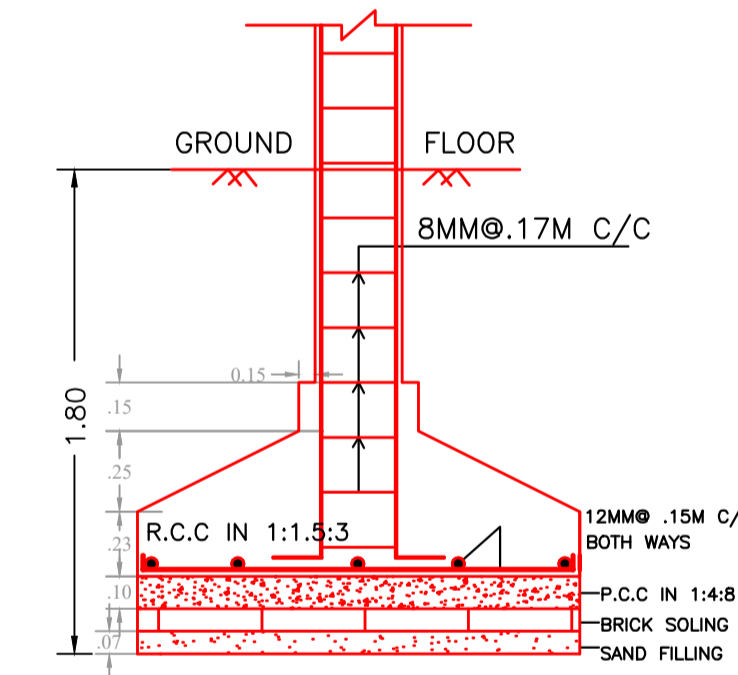
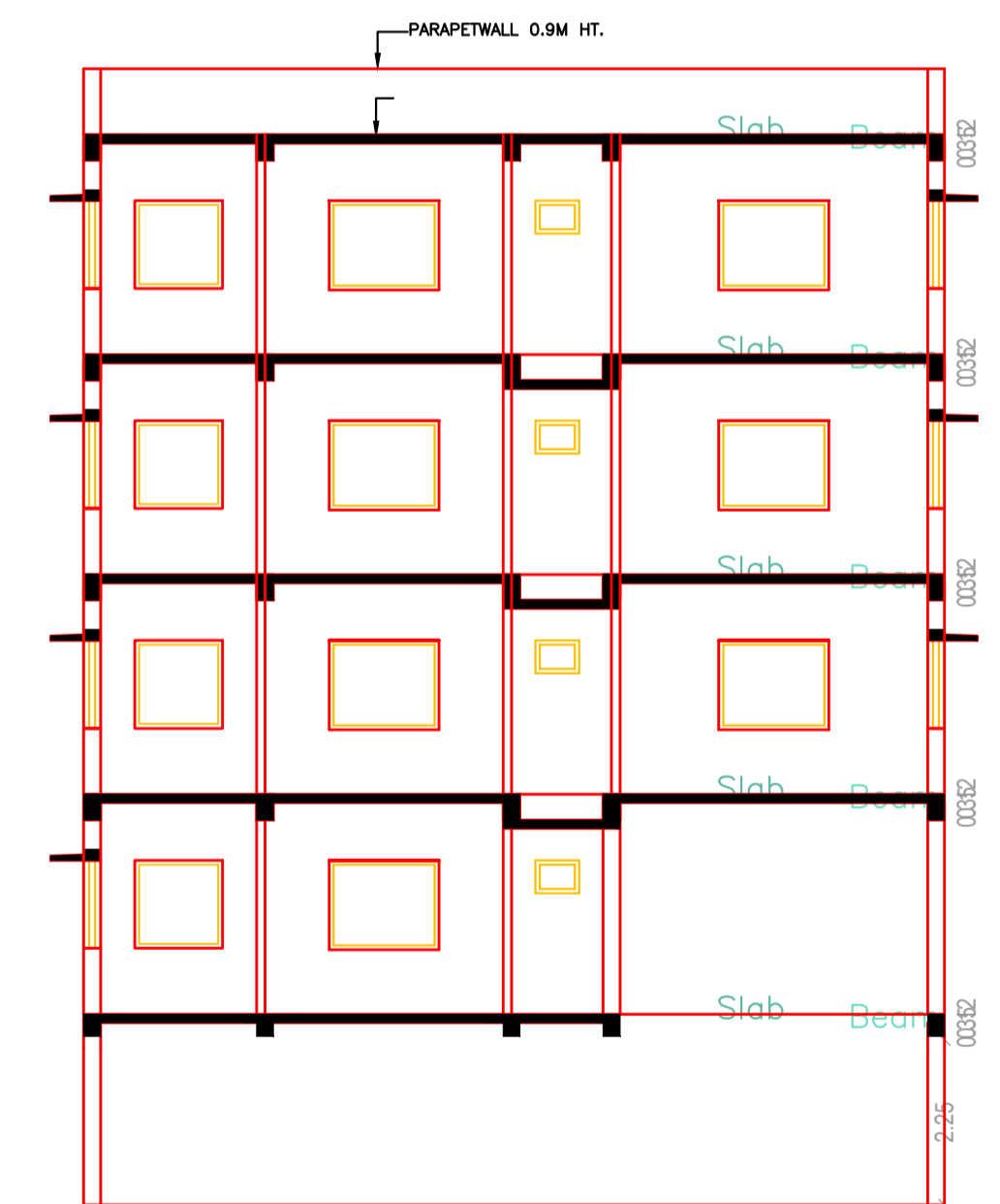
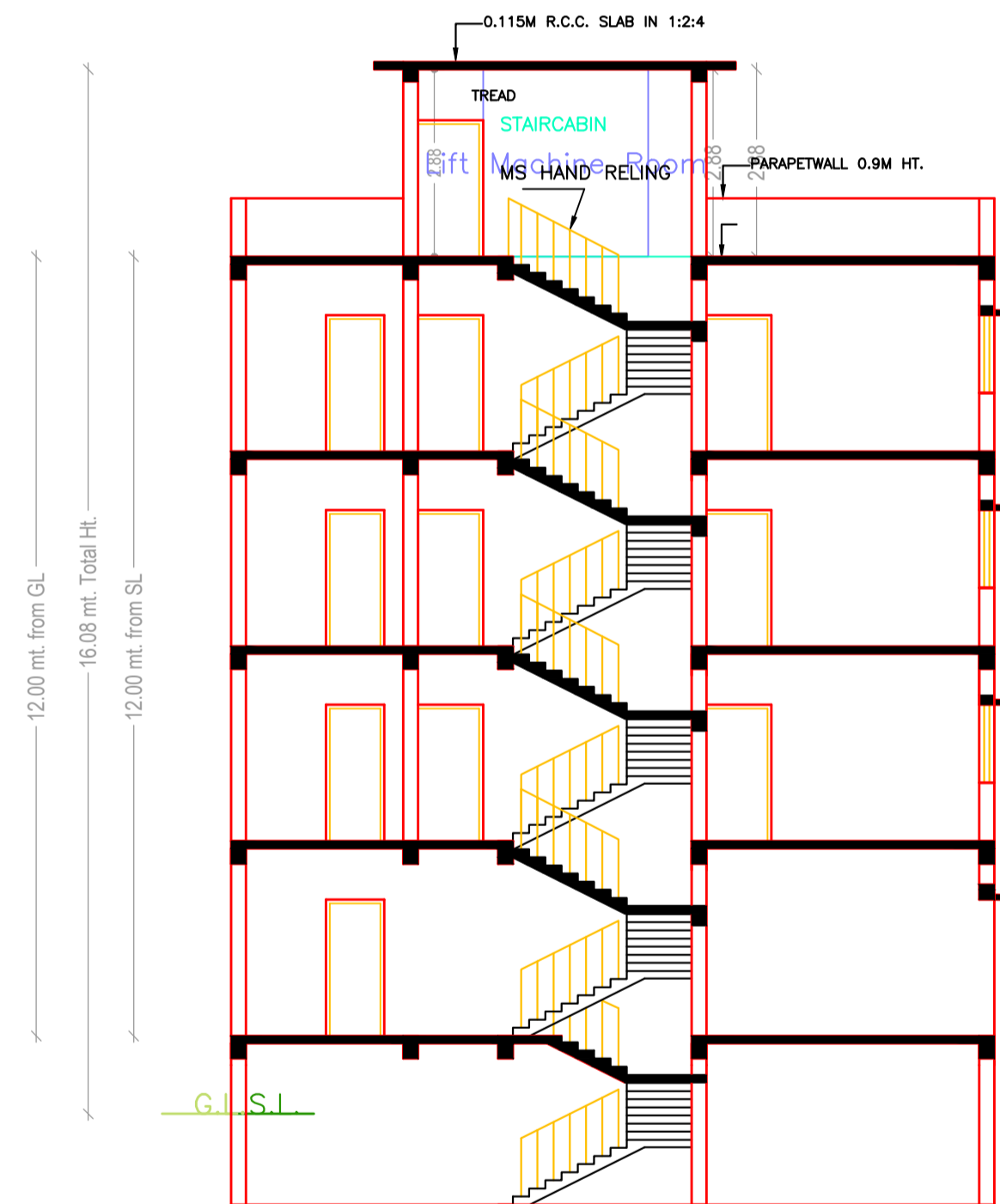

Building :A (RESIDENTIAL)

Floor Name	Gross Builtup Area	Deductions From Gross BUA (Area in Sq.mt.)	Total Built Up Area (Sq.mt.)	Deductions (Area in Sq.mt.)		Proposed FAR Area (Sq.mt.)	Add Area In FAR (Sq.mt.)	Total FAR Area (Sq.mt.)	Total Consumed Additional FAR Area (Sq.mt.)	Trmt (No.)
				Lift	Parking					
Basement Floor	128.90	0.00	128.90	3.23	101.13	0.00	9.19	9.19	9.19	00
Ground Floor	128.90	13.17	115.73	0.00	0.00	115.73	0.00	115.73	115.73	01
First Floor	132.42	0.00	132.42	3.23	0.00	129.19	0.00	129.19	129.19	00
Second Floor	132.42	0.00	132.42	3.23	0.00	129.19	0.00	129.19	129.19	00
Third Floor	132.42	0.00	132.42	3.23	0.00	129.19	0.00	129.19	129.19	00
Terrace Floor	0.00	0.00	0.00	0.00	0.00	0.00	0.00	0.00	0.00	00
Total :	655.06	13.17	641.89	12.92	101.13	503.30	9.19	512.49	512.49	01
Total Number of Same Buildings :	1									
Total :	655.06	13.17	641.89	12.92	101.13	503.30	9.19	512.49	512.49	01

SCHEDULE OF DOOR:

BUILDING NAME	NAME	LENGTH	HEIGHT	NOS
A (RESIDENTIAL)	D	0.70	2.10	01
A (RESIDENTIAL)	D2	0.75	2.10	04
A (RESIDENTIAL)	D1	0.90	2.10	07
A (RESIDENTIAL)	D	1.00	2.10	17
A (RESIDENTIAL)	RS	2.95	2.10	01
A (RESIDENTIAL)	RS	3.96	2.10	01

SCHEDULE OF WINDOW/VENTILATION:

BUILDING NAME	NAME	LENGTH	HEIGHT	NOS
A (RESIDENTIAL)	V	0.60	0.75	04
A (RESIDENTIAL)	W1	1.20	1.20	12
A (RESIDENTIAL)	W	1.50	1.50	24

UnitBUA Table for Building :A (RESIDENTIAL)

FLOOR	Name	UnitBUA Type	UnitBUA Area	Carpet Area	No. of Rooms	No. of Tenement
GROUND FLOOR PLAN	SPLIT A	FLAT	392.34	378.93	6	1
TYPICAL - 1- 3 FLOOR PLAN	SPLIT A	FLAT	0.00	0.00	8	0
Total:	-	-	392.34	378.93	30	1

LTP NAME AND SIGNATURE	STRUCTURAL ENG'S NAME AND SIGNATURE	BUILDER NAME AND SIGNATURE	DIGITAL SIGNATURE
EJAZ AHMAD MNAC/DFTMN/0008/2020			

