

TERRACE FLOOR PLAN (SCALE 1:100)

FAR & Tenement Details (Table 4c-1)

Building	No. of Same Bldg	Total Built Up Area (Sq.mt.)	Proposed FAR Area (Sq.mt.) Resi.	Total FAR Area (Sq.mt.)	Total Consumed Additional FAR Area (Sq.mt.)	Tnmt (No.)
DUPLEX (26)	1	86.94	86.94	86.94	86.94	01
Grand Total :	1	86.94	86.94	86.94	86.94	01

Proposal Basic Information

Proposal File No.	MNAC/BP/0076/W10/2022
Owner Name	SHRI NETRA MOHAN PRADHAN
Khata No	319
Plot No	3966
Village Name	Mango
Use	Residential
SubUse	Other Residential Building

AREA STATEMENT MANGO MUNICIPAL CORPORATION

VERSION NO. : 1.0.64
VERSION DATE: 16/10/2020

PROJECT DETAIL:

Region : JHARKHAND URBAN LOCAL BODIES	Plot Use: Residential
District: EAST SINGHBHUM	Plot SubUse: Other Residential Building
Authority: MANGO MUNICIPAL CORPORATION	PlotNearby/ReligiousStructure: NA
Inward No: MNAC/BP/0076/W10/2022	Plot/SubPlot No: 3966
Application Type: General Proposal	North: Plot No. - 3974
Project Type: Building Permission	South: Road Width - 6.1
Nature of Development: New	East: Plot No. - NIJ BOUNDRY
Location of Development Area: Old Area	West: Plot No. - NIJ PLOT

AREA DETAILS:

AREA OF PLOT (Minimum)	(A)	SQ.MT.
NET AREA OF PLOT(Gross Plot Area - Deduction from Gross Plot area)	(A-Deductions)	83.12
Deduction for Balance Plot Area(from Gross Plot Area)		
Common Plot		13.32
Total		13.32
BALANCE AREA OF PLOT(Net Plot Area - Recreational/Amenity space)	(A-Deductions)	69.80
PLOT AREA FOR COVERAGE(Net Plot Area)	(A-Deductions)	83.12
Plot Area for FAR (Net Plot Area + Road Widening Area)	(A-Deductions)	83.12

COVERAGE CHECK

Permissible Coverage area (70.00 %)	58.18
Proposed Coverage Area (47.78 %)	39.71
Total Prop. Coverage Area (47.78 %)	39.71
Balance coverage area (22.22 %)	18.47

FAR CHECK

Perm. FAR Area (2.500)	207.80
Total Perm. FAR area	207.80
Residential FAR	86.94
Proposed FAR Area	86.94
Total Proposed FAR Area	86.94
Consumed FAR (Factor)	1.05
Balance FAR Area	120.86

BUILT UP AREA CHECK

Total Proposed BuiltUp Area	86.94
ARCHITECT (Regd)	SATISH KUMAR
ENGINEER (Regd)	
SUPERVISOR (Regd)	
OWNER (Regd)	SHRI NETRA MOHAN PRADHAN
DEVELOPMENT AUTHORITY	LOCAL BODY

SITE PLAN

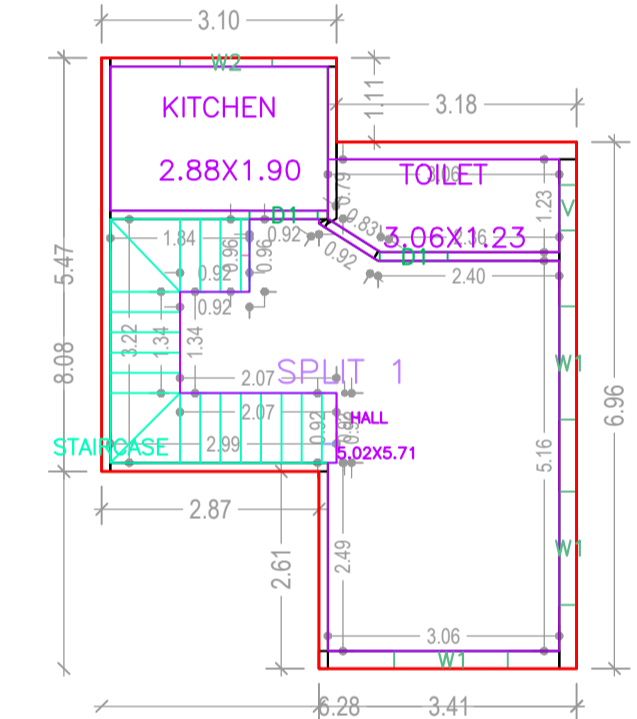

GROUND FLOOR PLAN (Proposed) (SCALE 1:100)

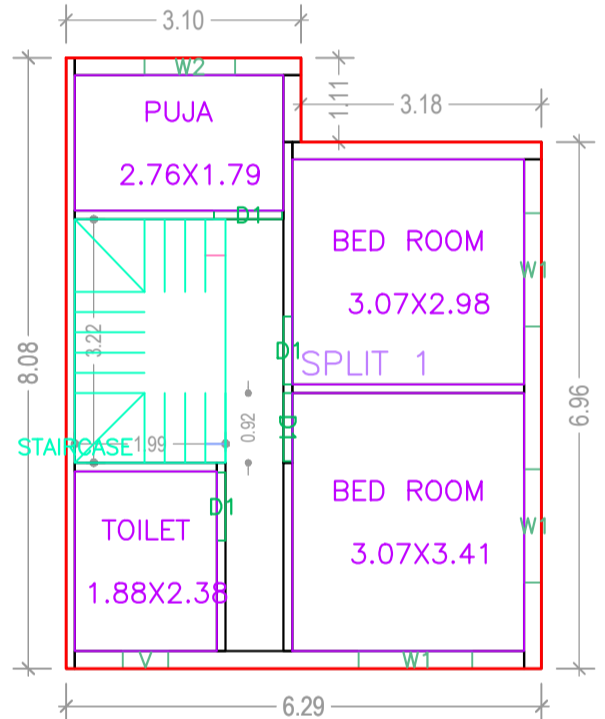

FIRST FLOOR PLAN (Proposed) (SCALE 1:100)

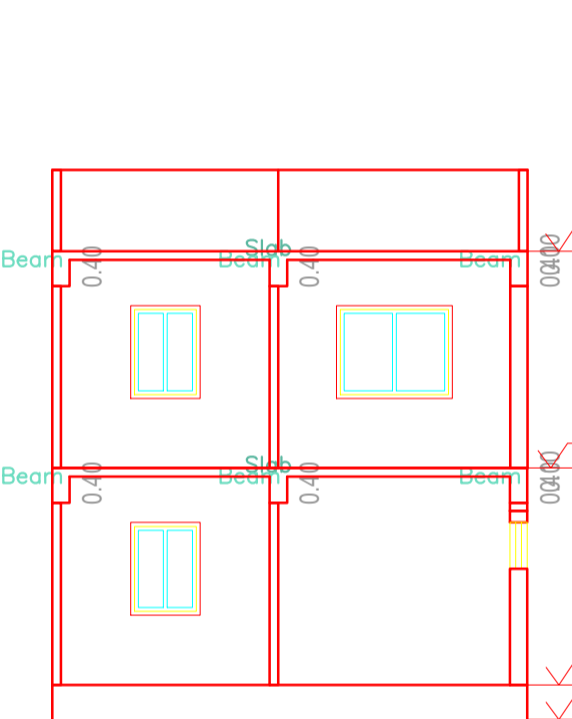

SECTION AT A - A (SCALE : 1:100)

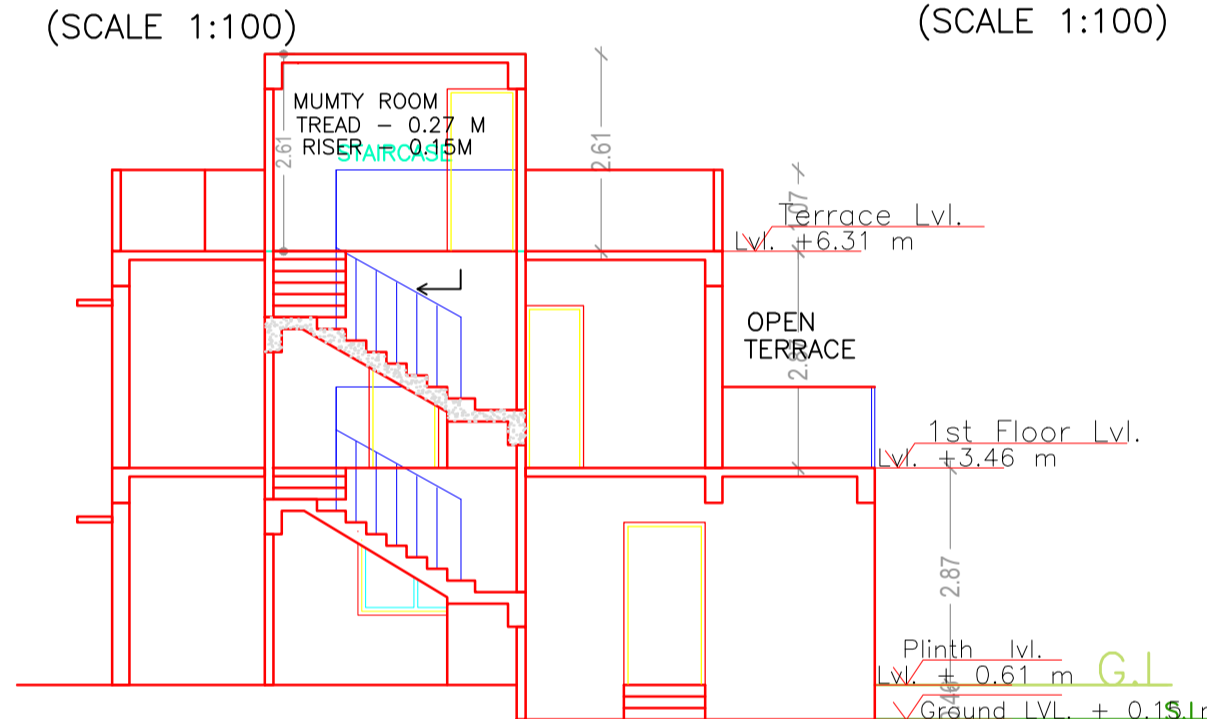

SECTION AT B - B (SCALE : 1:100)

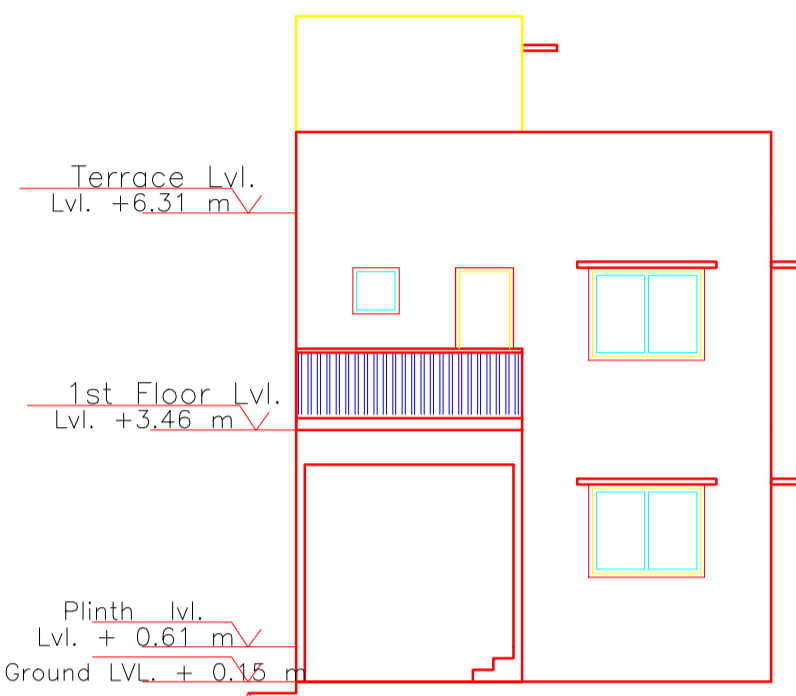

FRONT ELEVATION (SCALE - 1:100)

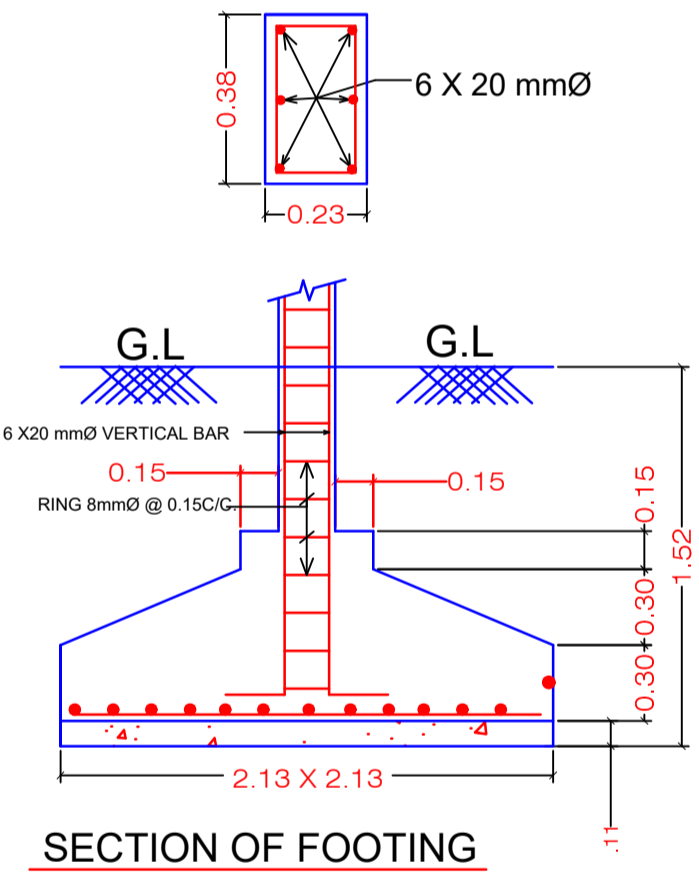

SECTION OF FOOTING

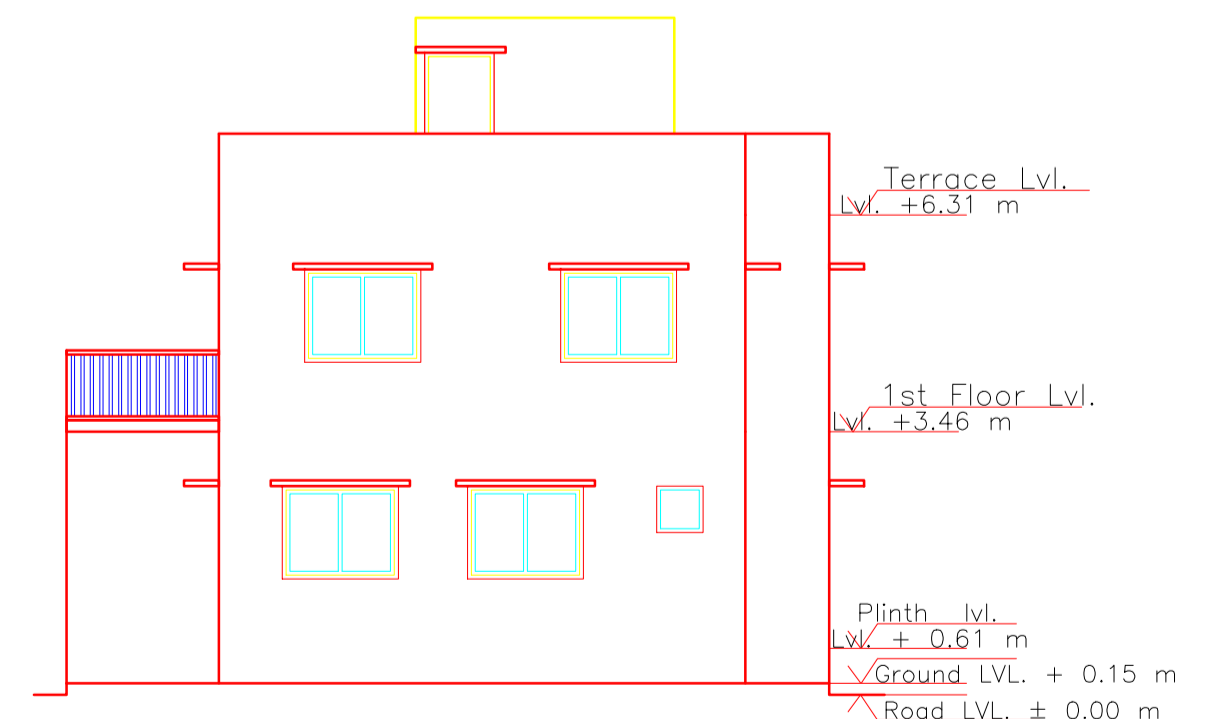

RIGHT SIDE ELEVATION (SCALE - 1:100)

COLOR INDEX

PLOT BOUNDARY	Black
ABUTTING ROAD	Green
PROPOSED CONSTRUCTION	Red
COMMON PLOT	Yellow
ROAD WIDENING AREA	Blue
EXISTING (To be retained)	Orange
EXISTING (To be demolished)	Light Blue

Buildingwise Floor FAR Details

Floor Name	Building Name DUPLEX (26)		Total	
	Proposed Built Up Area (Sq.mt.)	Proposed FAR Area (Sq.mt.)	Total Proposed Built Up Area (Sq.mt.)	Total FAR Area (Sq.mt.)
Ground Floor	39.71	39.71	39.71	39.71
First Floor	47.23	47.23	47.23	47.23
Terrace Floor	0.00	0.00	0.00	0.00
Total :	86.94	86.94	86.94	86.94

Building USE/SUBUSE Details

Building Name	Building Use	Building SubUse	Building Structure
DUPLEX (26)	Residential	Other Residential Building	Non-Highrise

Building :DUPLEX (26)

Floor Name	Total Built Up Area (Sq.mt.)	Proposed FAR Area (Sq.mt.) Resi.	Total FAR Area (Sq.mt.)	Total Consumed Additional FAR Area (Sq.mt.)	Tnmt (No.)
Ground Floor	39.71	39.71	39.71	39.71	01
First Floor	47.23	47.23	47.23	47.23	00
Terrace Floor	0.00	0.00	0.00	0.00	00
Total :	86.94	86.94	86.94	86.94	01
Total Number of Same Buildings	1				
Total :	86.94	86.94	86.94	86.94	01

SCHEDULE OF DOOR:

BUILDING NAME	NAME	LENGTH	HEIGHT	NOS
DUPLEX (26)	D1	0.90	2.10	06

SCHEDULE OF WINDOW/VENTILATION:

BUILDING NAME	NAME	LENGTH	HEIGHT	NOS
DUPLEX (26)	V	0.60	0.60	02
DUPLEX (26)	W2	1.20	1.20	01
DUPLEX (26)	W2	1.22	1.20	01
DUPLEX (26)	W1	1.50	1.20	06

UnitBUA Table for Building :DUPLEX (26)

FLOOR	Name	UnitBUA Type	UnitBUA Area	Carpet Area	No. of Rooms	No. of Tenement
GROUND FLOOR PLAN	SPLIT 1	FLAT	86.94	73.95	3	1
FIRST FLOOR PLAN	SPLIT 1	FLAT	0.00	0.00	4	0
Total:	-	-	86.94	73.95	7	1

LTP NAME AND SIGNATURE	STRUCTURAL ENG'S NAME AND SIGNATURE	BUILDER NAME AND SIGNATURE	DIGITAL SIGNATURE
SATISH KUMAR MNAC/DFTMN/0001/2017			