

Project Title: MRS MALIADI

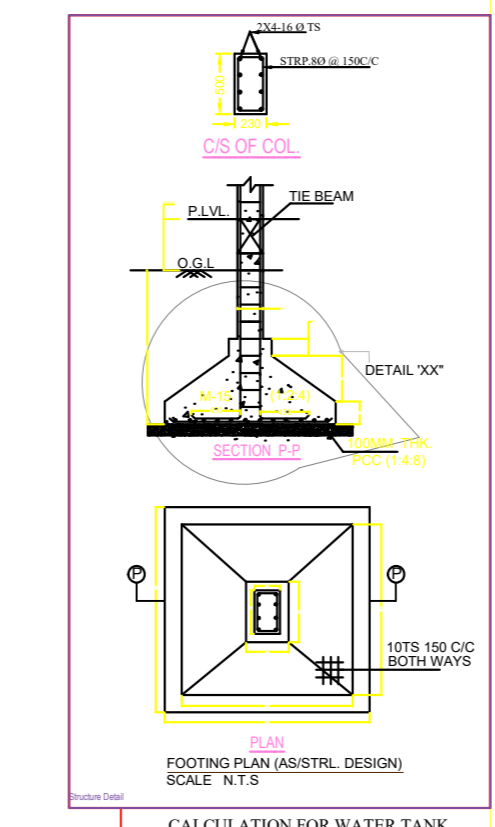
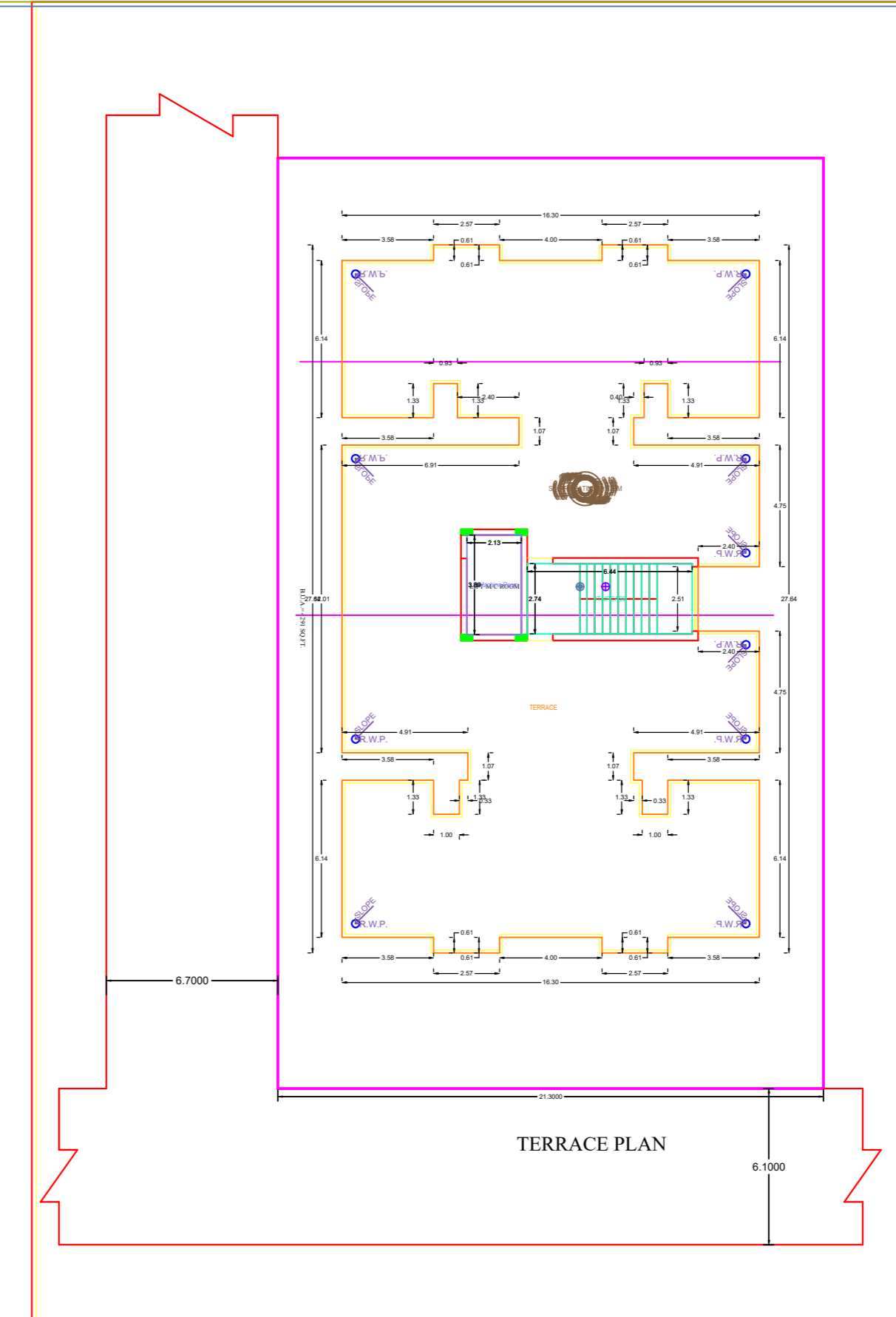
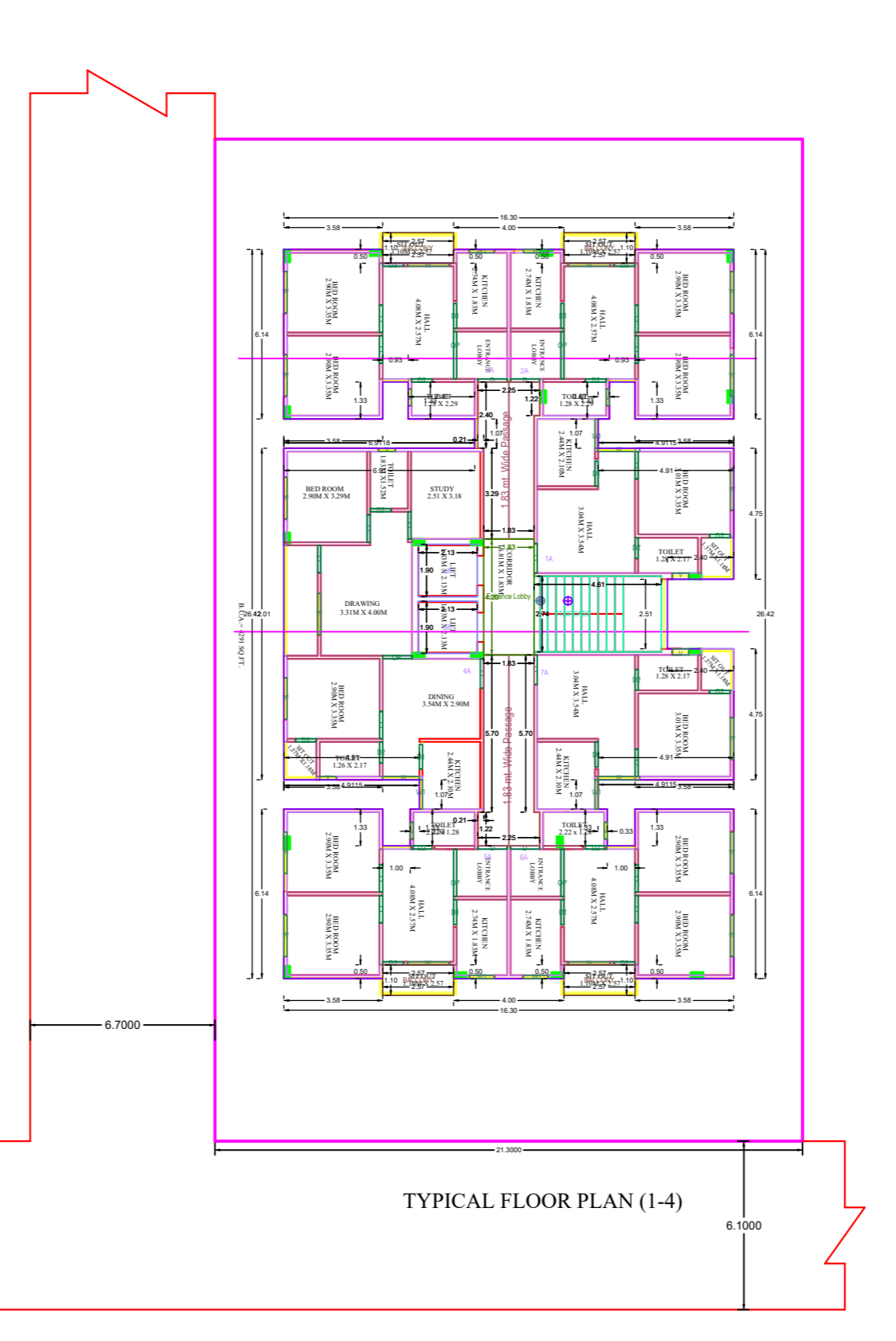
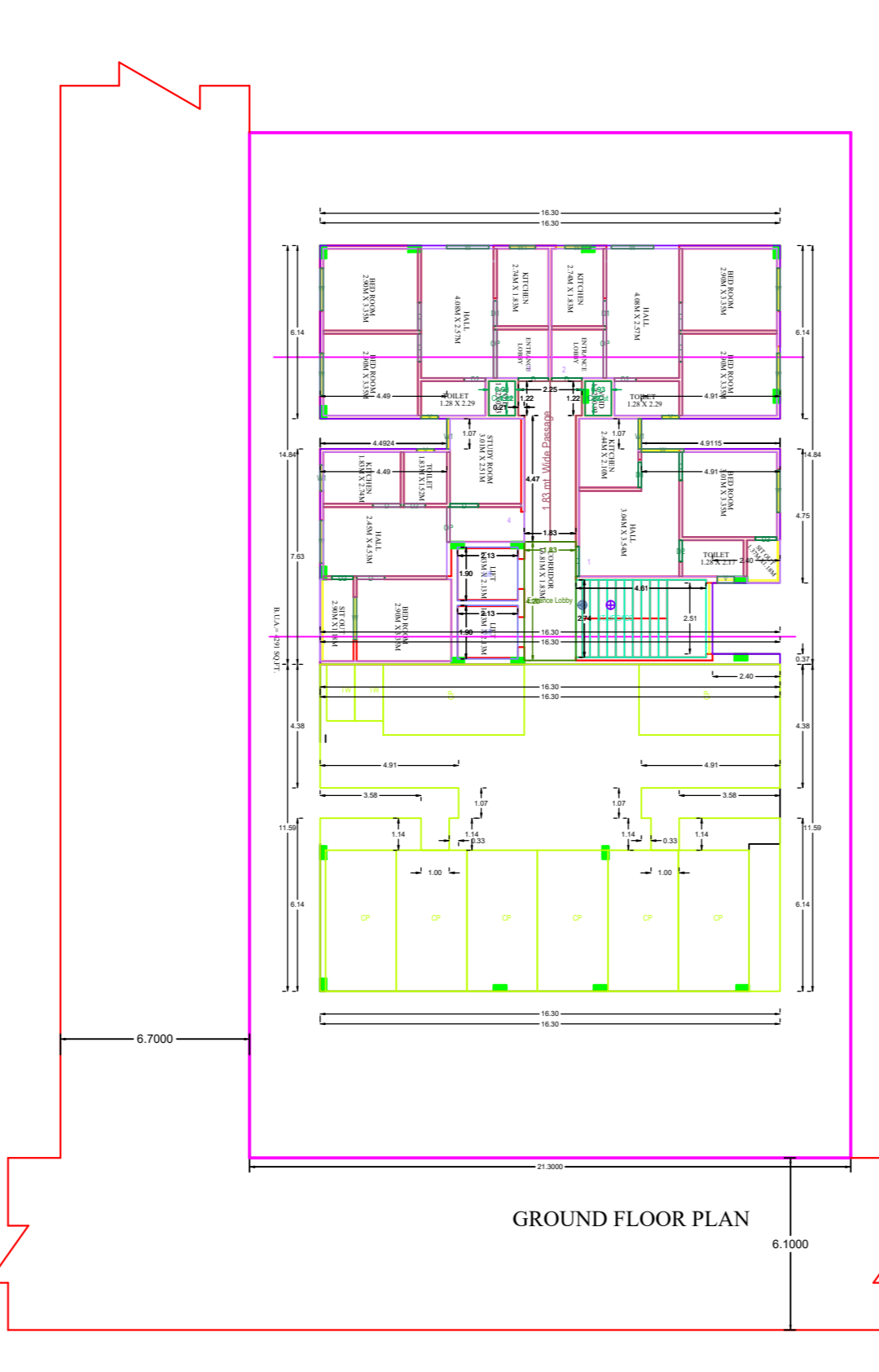
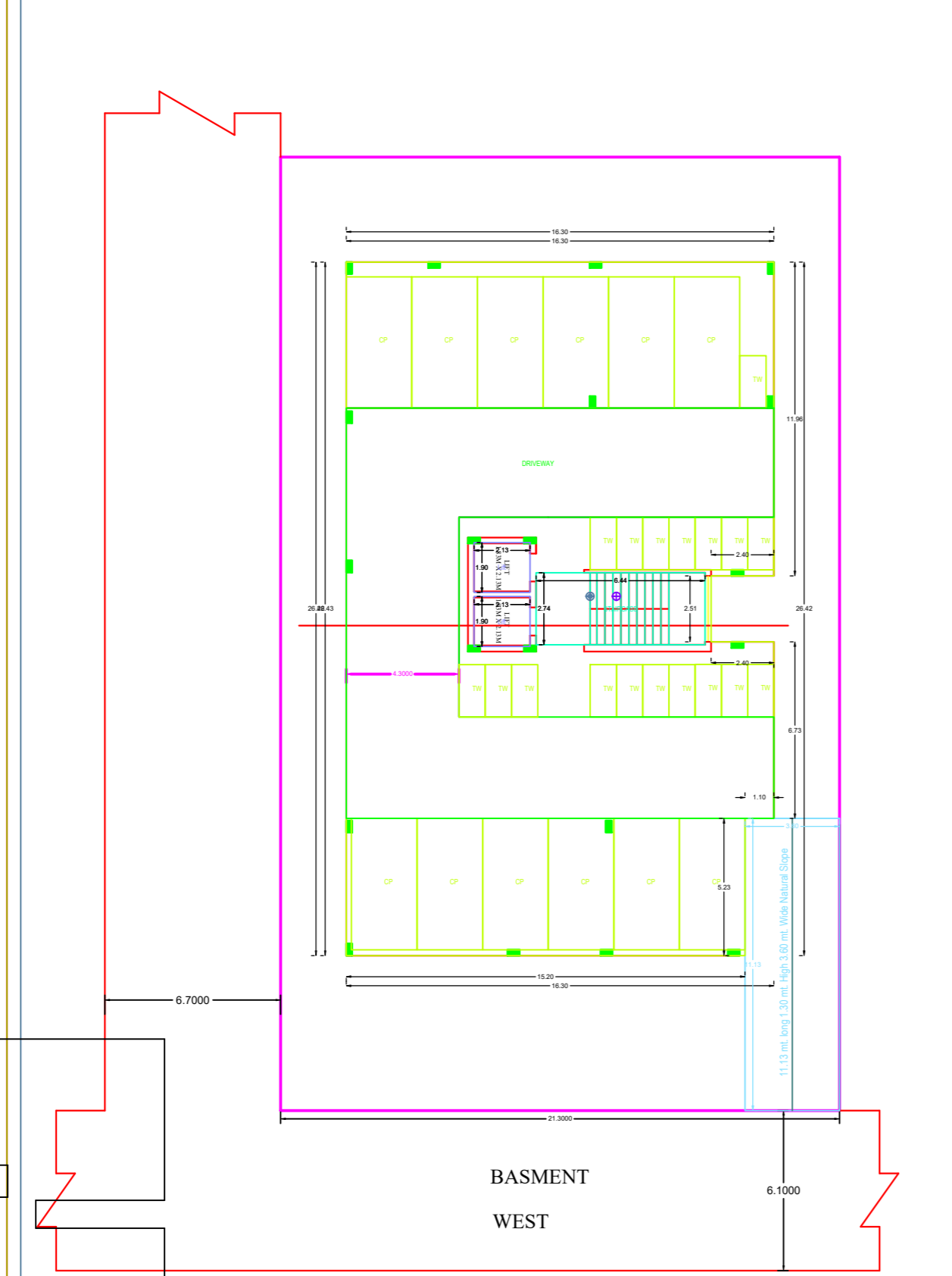
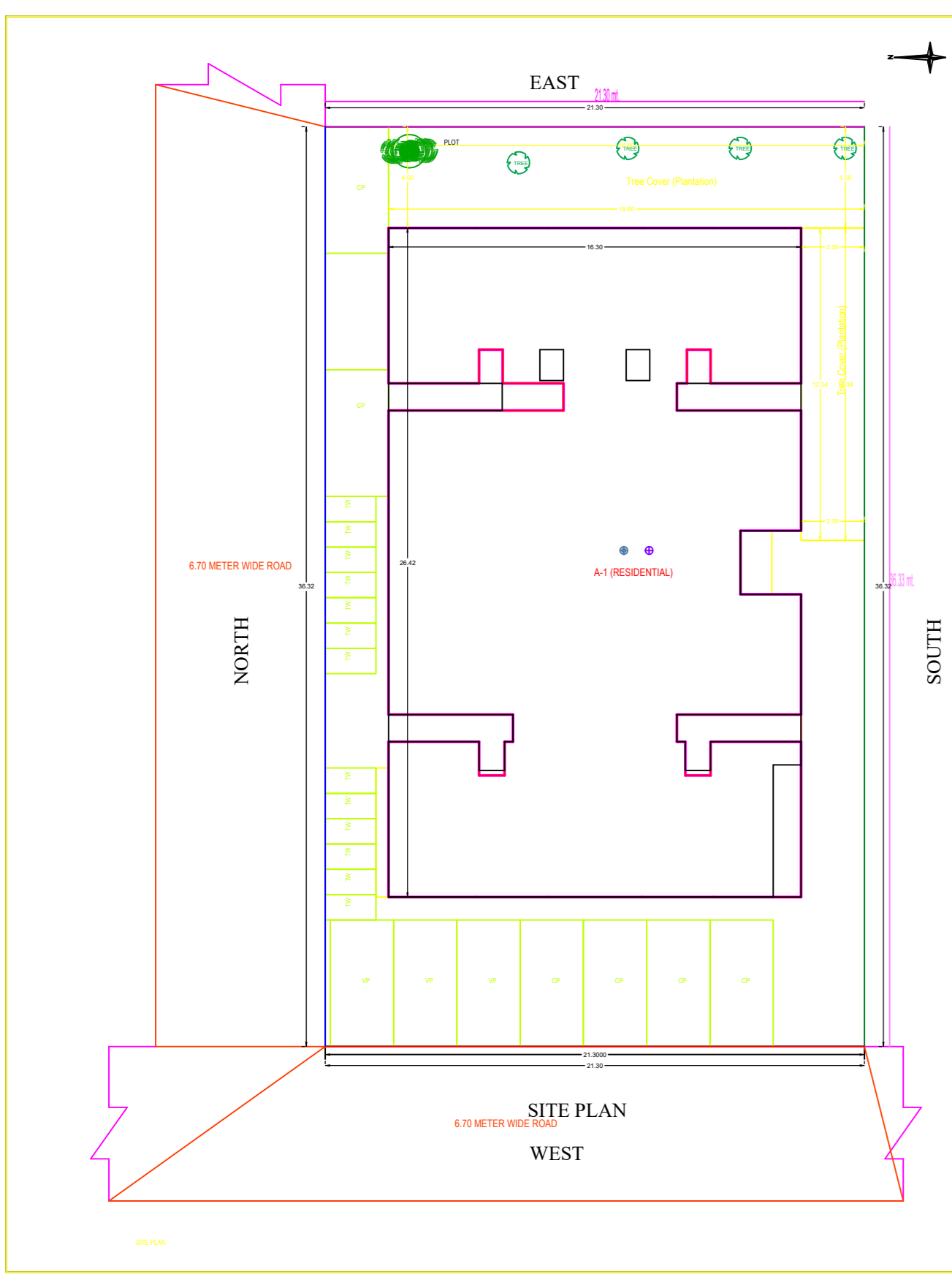
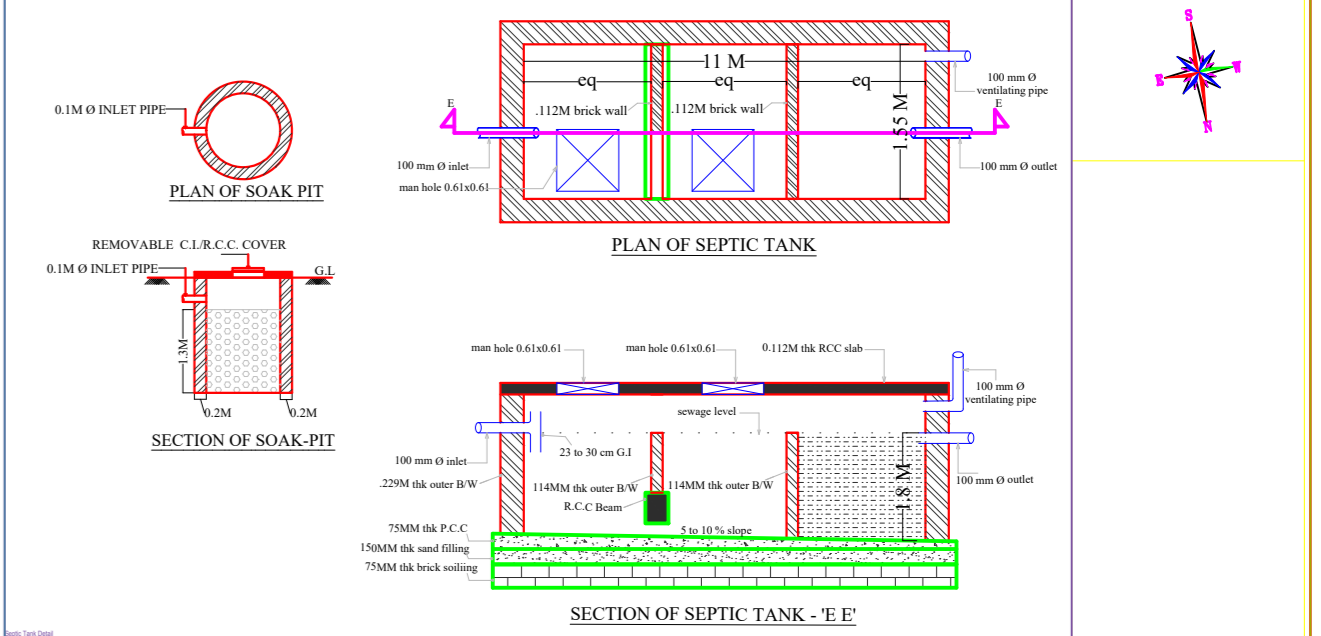
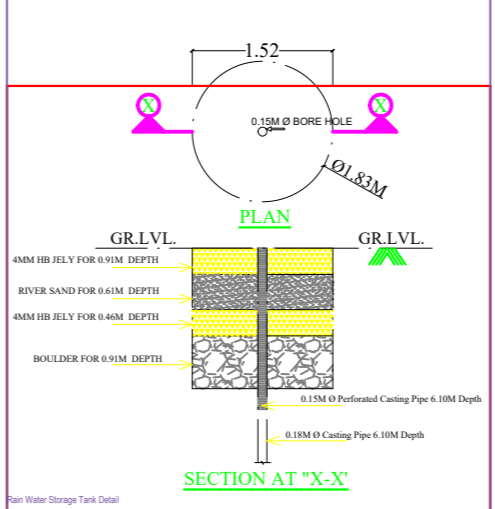
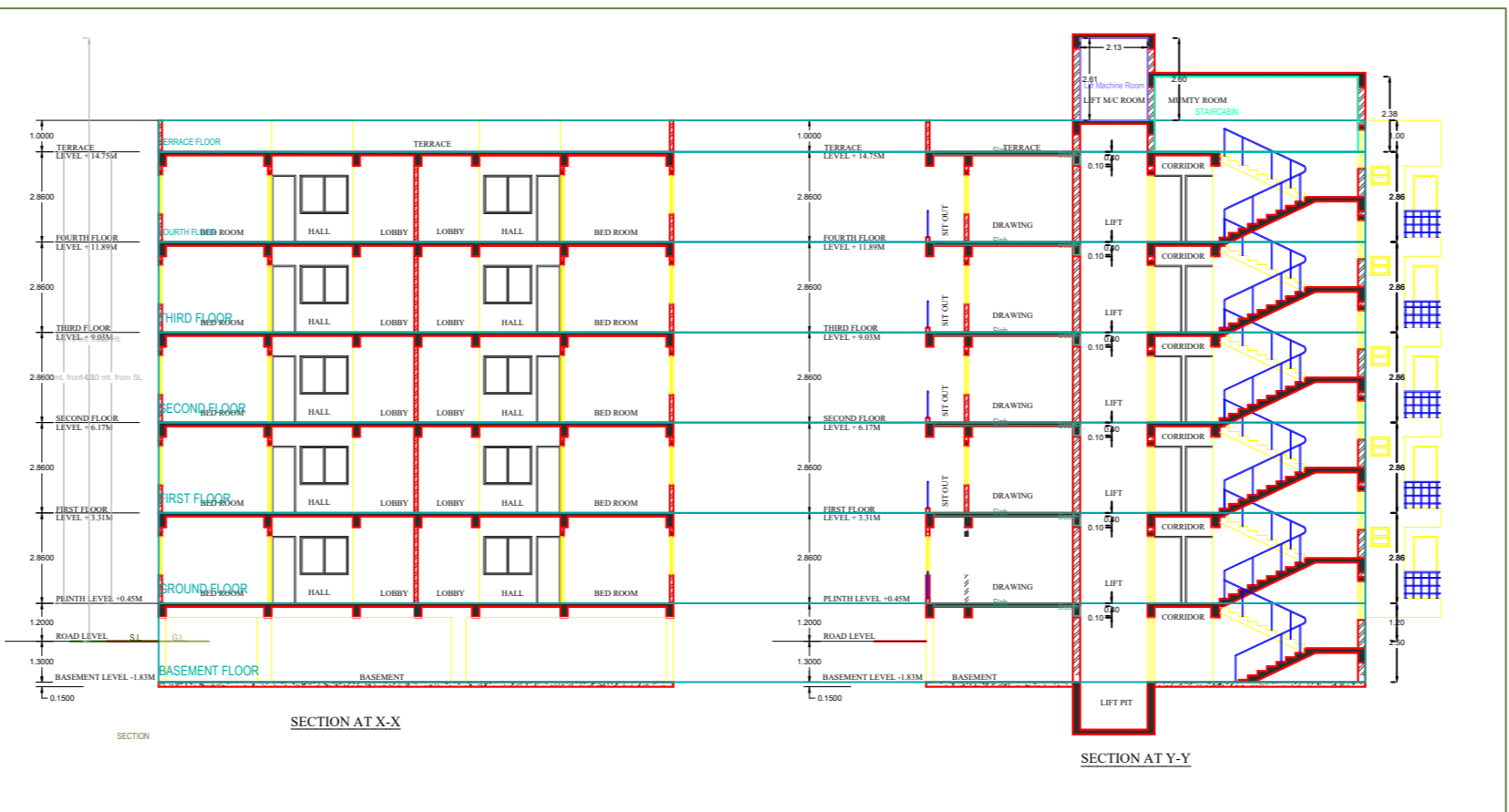

CALCULATION FOR WATER TANK

ASSUMPTIONS:

- 1. 10% OF TOTAL FLOOR AREA
- 2. 10% OF TOTAL FLOOR AREA
- 3. 10% OF TOTAL FLOOR AREA
- 4. 10% OF TOTAL FLOOR AREA
- 5. 10% OF TOTAL FLOOR AREA
- 6. 10% OF TOTAL FLOOR AREA
- 7. 10% OF TOTAL FLOOR AREA
- 8. 10% OF TOTAL FLOOR AREA
- 9. 10% OF TOTAL FLOOR AREA
- 10. 10% OF TOTAL FLOOR AREA

DATE: 10/10/2023

SCALE: 1:100

APPROVED:

