

Proposal Basic Information

Proposal File No.	MNAC/BP/0092/W09/2022
Owner Name	MRS. NANDA KUMARI w.o MR. SAILESH YADAV
Khata No	136
Plot No	1523
Village Name	Pardih
Use	Residential
SubUse	Bungalow/ Dwelling / Non Apartment

FAR & Tenement Details (Table 4c-1)

Building	No. of Same Bldg	Total Built Up Area (Sq.mt.)	Deductions (Area in Sq.mt.)		Proposed FAR Area (Sq.mt.)	Add Area In FAR (Sq.mt.)	Total FAR Area (Sq.mt.)	Total Consumed Additional FAR Area (Sq.mt.)	Trmnt (No.)
			Parking	Resi.					
A (RESIDENTIAL)	1	159.57	42.64	106.38	106.38	10.55	116.93	116.93	01
Grand Total :	1	159.57	42.64	106.38	106.38	10.55	116.93	116.93	01

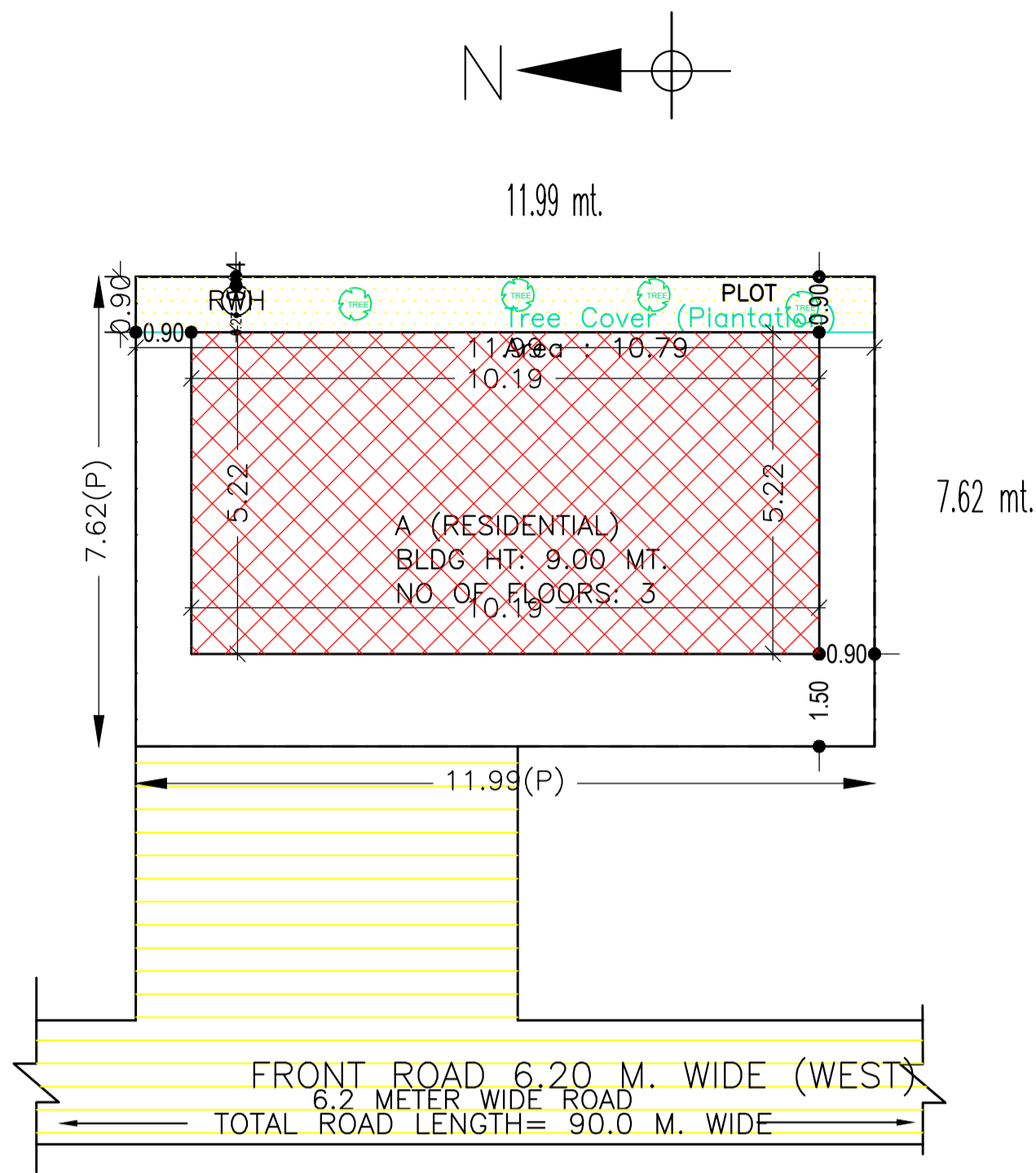

SITE PLAN
SCALE 1:100

AREA STATEMENT MANGO MUNICIPAL CORPORATION	VERSION NO. : 1.0.65	VERSION DATE: 16/10/2020
PROJECT DETAIL:		
Region: JHARKHAND URBAN LOCAL BODIES	Plot Use: Residential	
District: EAST SINGHBHUM	Plot SubUse: Bungalow/ Dwelling / Non Apartment	
Authority: MANGO MUNICIPAL CORPORATION	PlotNearbyReligiousStructure: NA	
Inward No: MNAC/BP/0092/W09/2022	PlotSubPlot No: 1523	
Application Type: General Proposal	North: Plot No. - 1523	
Project Type: Building Permission	South: Plot No. - 1523	
Nature of Development: New	East: Plot No. - 1523	
Location of Development Area: Old Area	West: Road Width - 6.20	
AREA DETAILS:		
AREA OF PLOT (Minimum)	(A)	SQ.MT. 91.36
NET AREA OF PLOT(Gross Plot Area - Deduction from Gross Plot area)	(A-Deductions)	91.36
Deduction for Balance Plot Area(from Gross Plot Area)		
Common Plot		10.79
Total		10.79
BALANCE AREA OF PLOT(Net Plot Area - Recreational/Armenity space)	(A-Deductions)	80.57
PLOT AREA FOR COVERAGE(Net Plot Area)	(A-Deductions)	91.36
Plot Area for FAR (Net Plot Area + Road Widening Area)	(A-Deductions)	91.36
COVERAGE CHECK		
Permissible Coverage area (70.00 %)		63.95
Proposed Coverage Area (58.22 %)		53.19
Total Prop. Coverage Area (58.22 %)		53.19
Balance coverage area (11.78 %)		10.76
FAR CHECK		
Perm. FAR Area (2.500)		228.40
Total Perm. FAR area		228.40
Residential FAR		106.38
Proposed FAR Area		116.94
Total Proposed FAR Area		116.94
Consumed FAR (Factor)		1.28
Balance FAR Area		111.46
BUILT UP AREA CHECK		
Total Proposed BuiltUp Area		159.57
ARCHITECT (Regd)	Chandrika Sharma	
ENGINEER (Regd)		
SUPERVISOR (Regd)		
OWNER (Regd)	MRS. NANDA KUMARI w.o MR. SAILESH YADAV	
DEVELOPMENT AUTHORITY	LOCAL BODY	

COLOR INDEX	
PLOT BOUNDARY	Black
ABUTTING ROAD	Green
PROPOSED CONSTRUCTION	Red
COMMON PLOT	Yellow
ROAD WIDENING AREA	Orange
EXISTING (To be retained)	Blue
EXISTING (To be demolished)	Light Blue

Buildingwise Floor FAR Details

Floor Name	Building Name A (RESIDENTIAL)		Total	
	Proposed Built Up Area (Sq.mt.)	Proposed FAR Area (Sq.mt.)	Total Proposed Built Up Area (Sq.mt.)	Total FAR Area (Sq.mt.)
Ground Floor	53.19	10.55	53.19	10.55
First Floor	53.19	53.19	53.19	53.19
Second Floor	53.19	53.19	53.19	53.19
Terrace Floor	0.00	0.00	0.00	0.00
Total :	159.57	116.93	159.57	116.93

Building USE/SUBUSE Details

Building Name	Building Use	Building SubUse	Building Structure
A (RESIDENTIAL)	Residential	Bungalow/ Dwelling / Non Apartment	Non-Highrise

LTP NAME AND SIGNATURE	STRUCTURAL ENG'S NAME AND SIGNATURE	BUILDER NAME AND SIGNATURE	DIGITAL SIGNATURE
Chandrika Sharma MNAC/DFTMN/0017/2017			

Proposal Basic Information	
Proposal File No.	MNAC/BP/0092/W09/2022
Owner Name	MRS. NANDA KUMARI w.o MR. SAILESH YADAV
Khata No	136
Plot No	1523
Village Name	Pardih
Use	Residential
SubUse	Bungalow/ Dwelling / Non Apartment

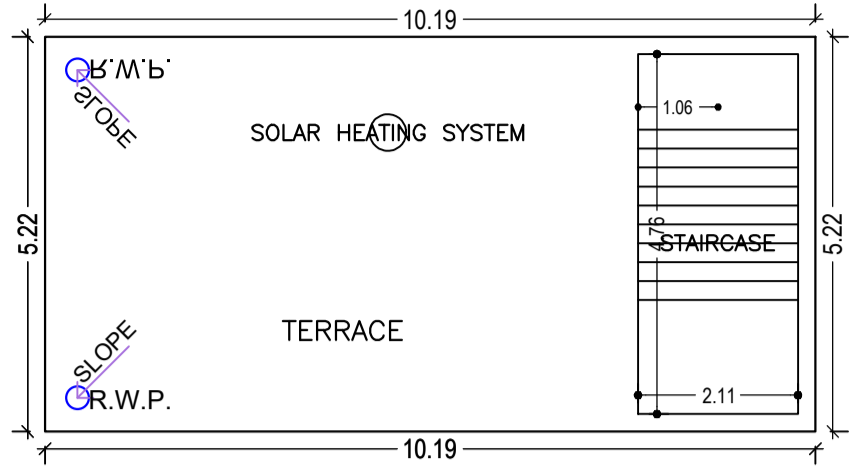
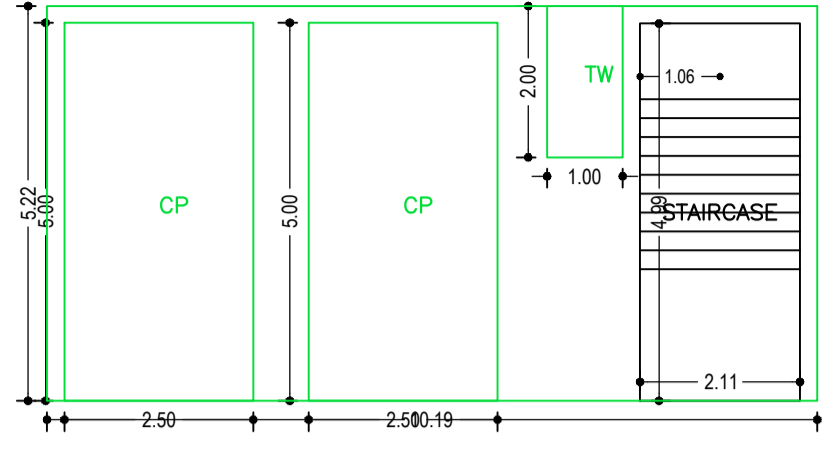

TERRACE FLOOR PLAN (SCALE 1:100)

GROUND FLOOR PLAN (SCALE 1:100)

SECOND FLOOR PLAN (Proposed) (SCALE 1:100)

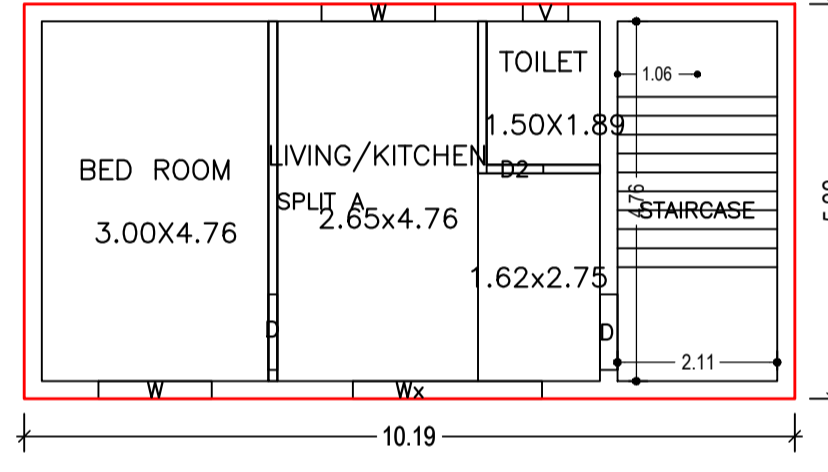

FIRST FLOOR PLAN (Proposed) (SCALE 1:100)

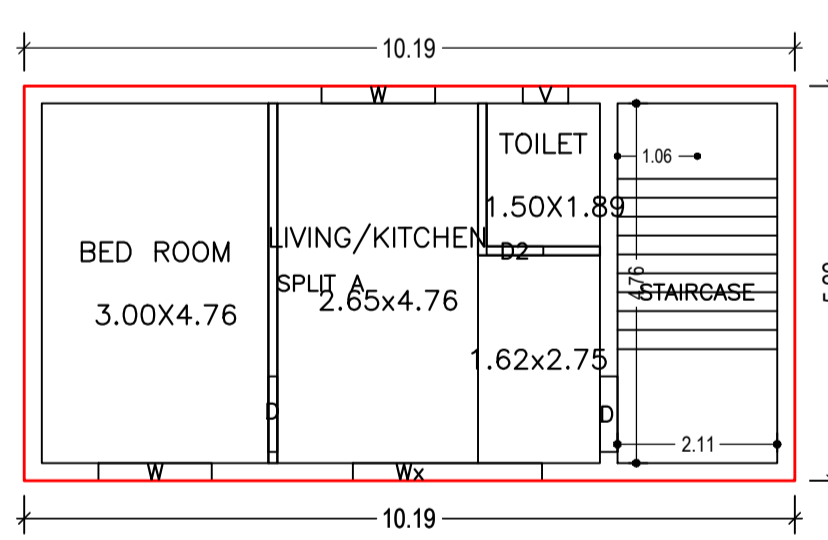

SECOND FLOOR PLAN (Proposed) (SCALE 1:100)

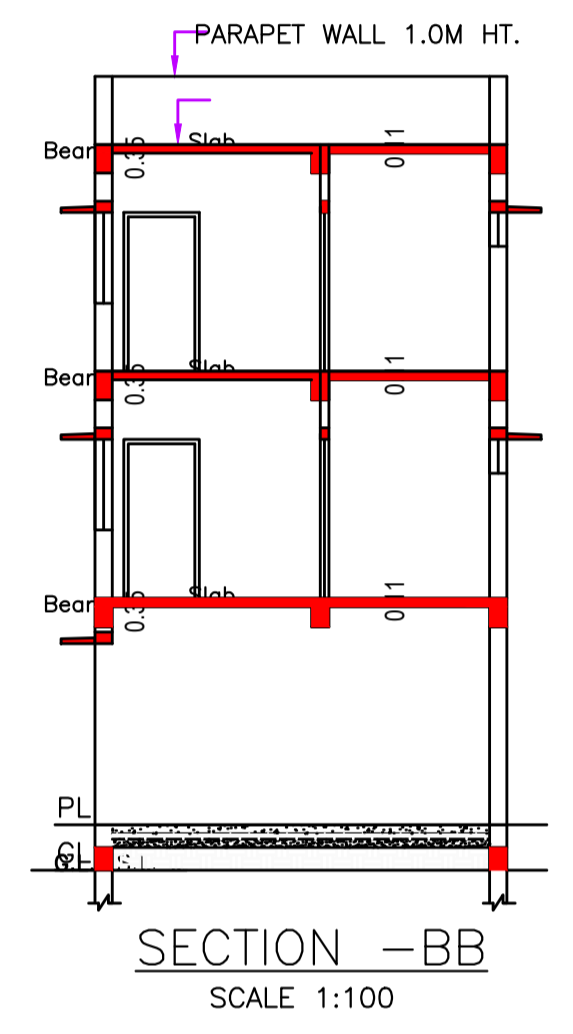

SECTION - BB (SCALE 1:100)

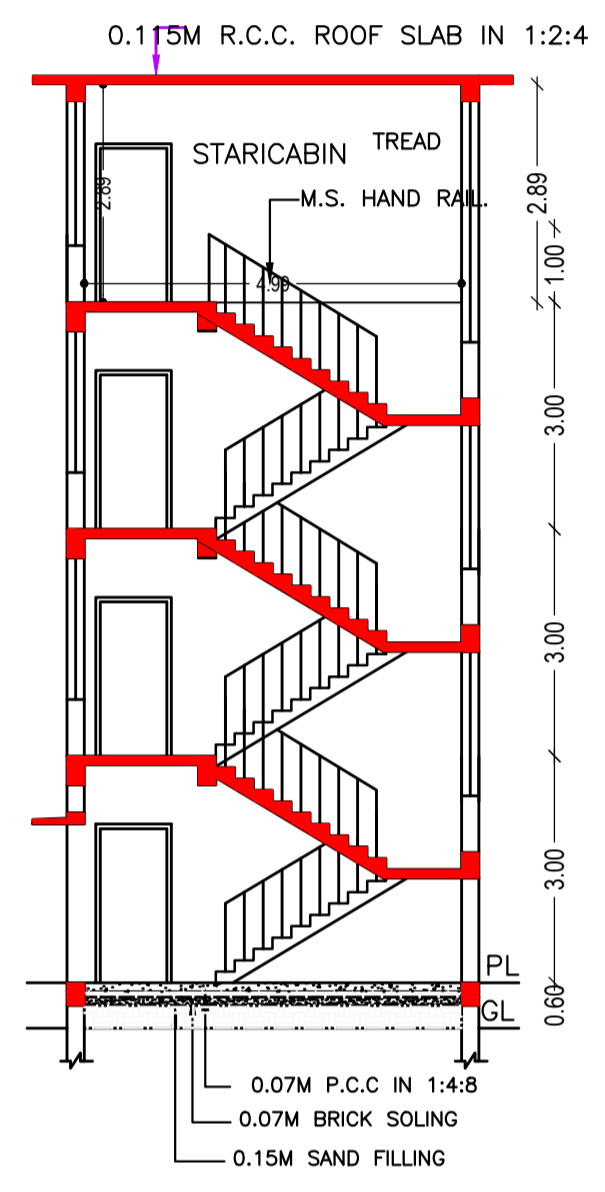

SECTION - A A (SCALE 1:100)

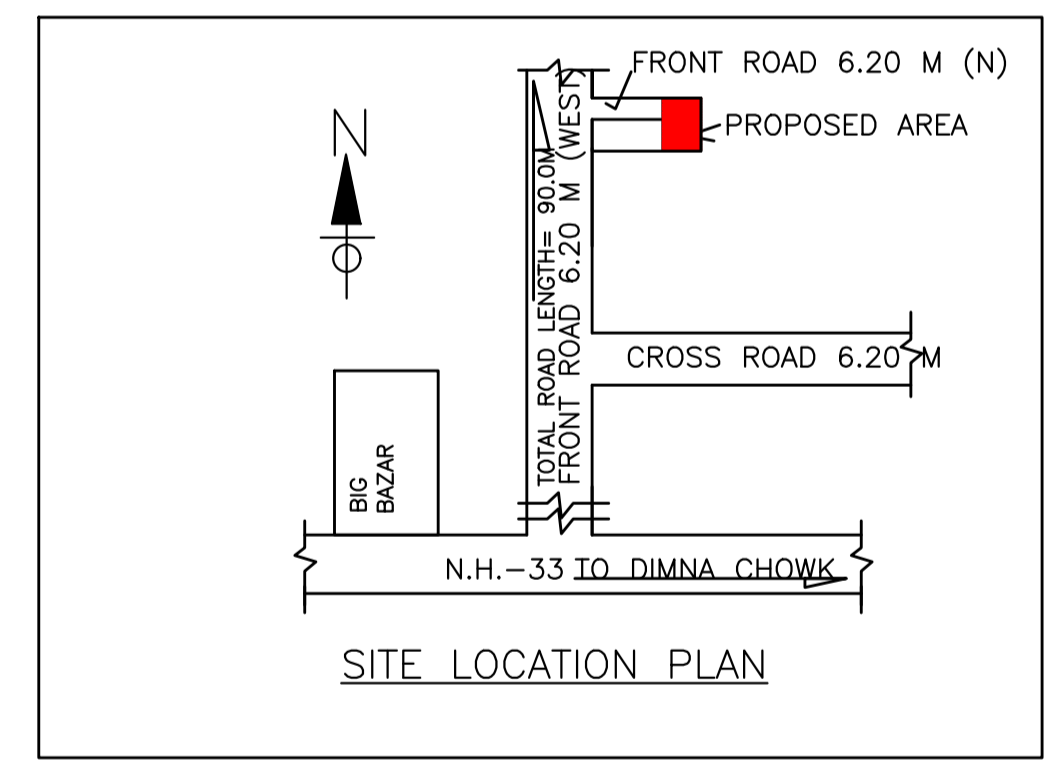

SITE LOCATION PLAN

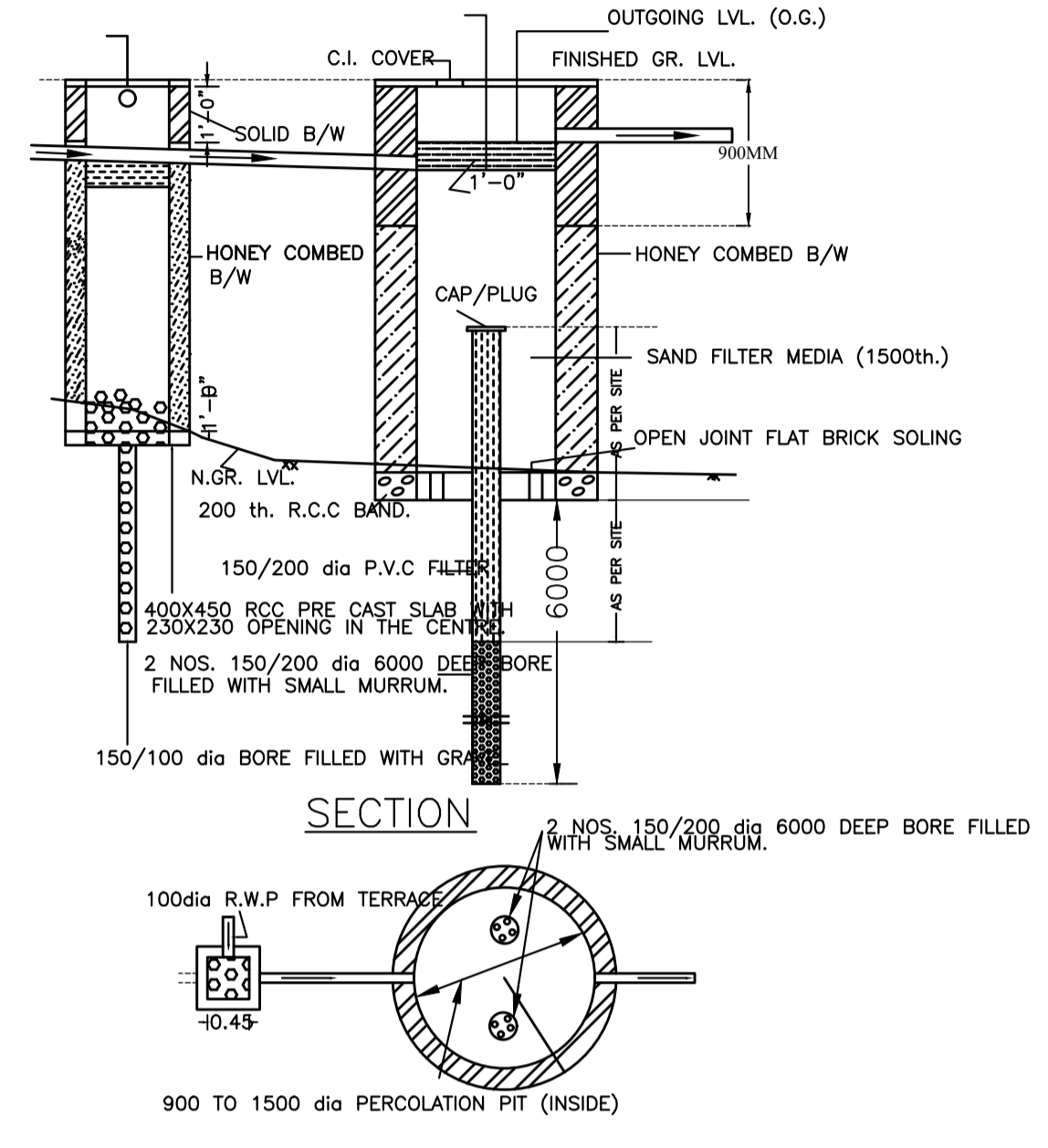

WATER HARVESTING PLAN (NTS)

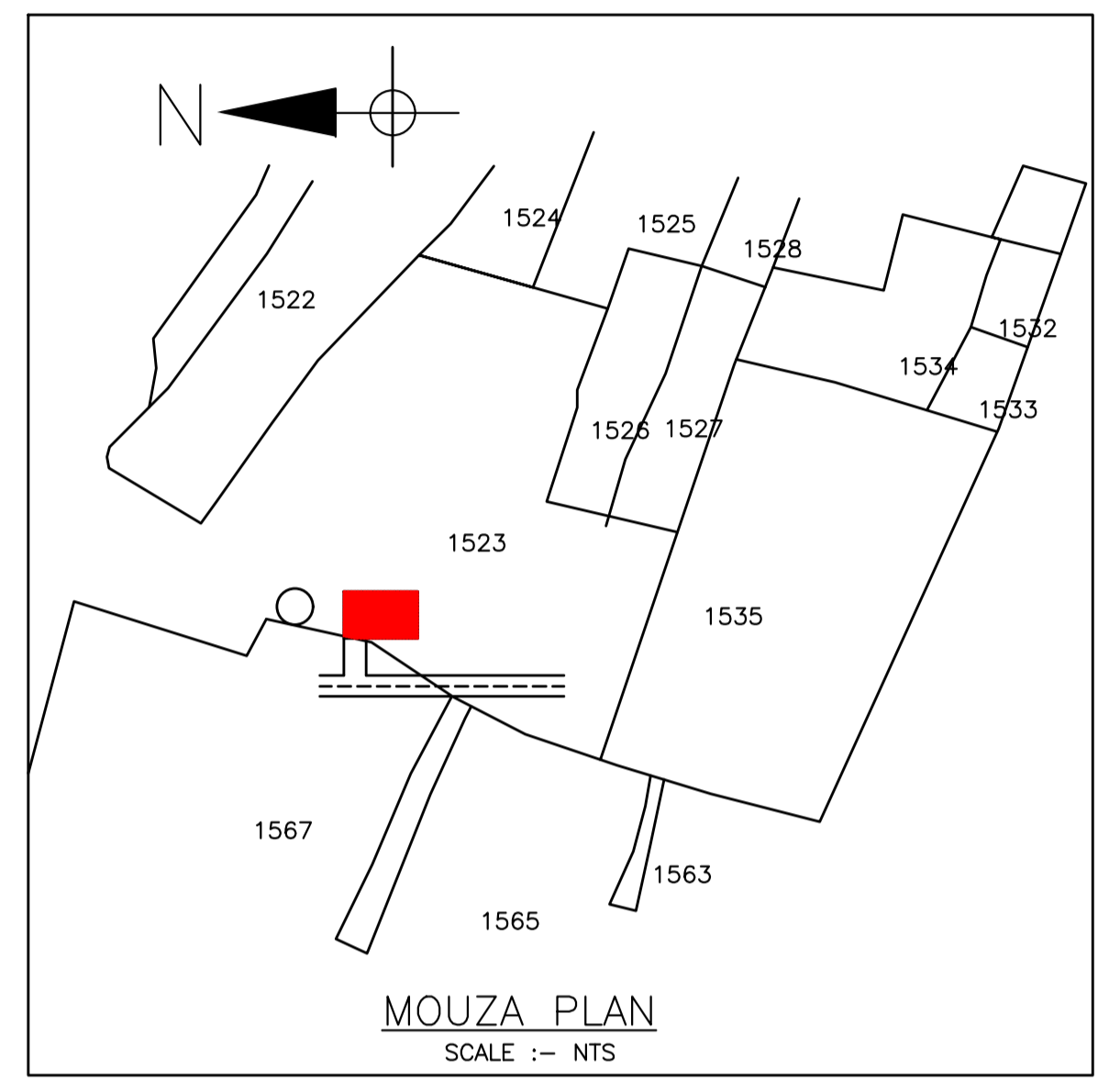

MOUZA PLAN (SCALE :- NTS)

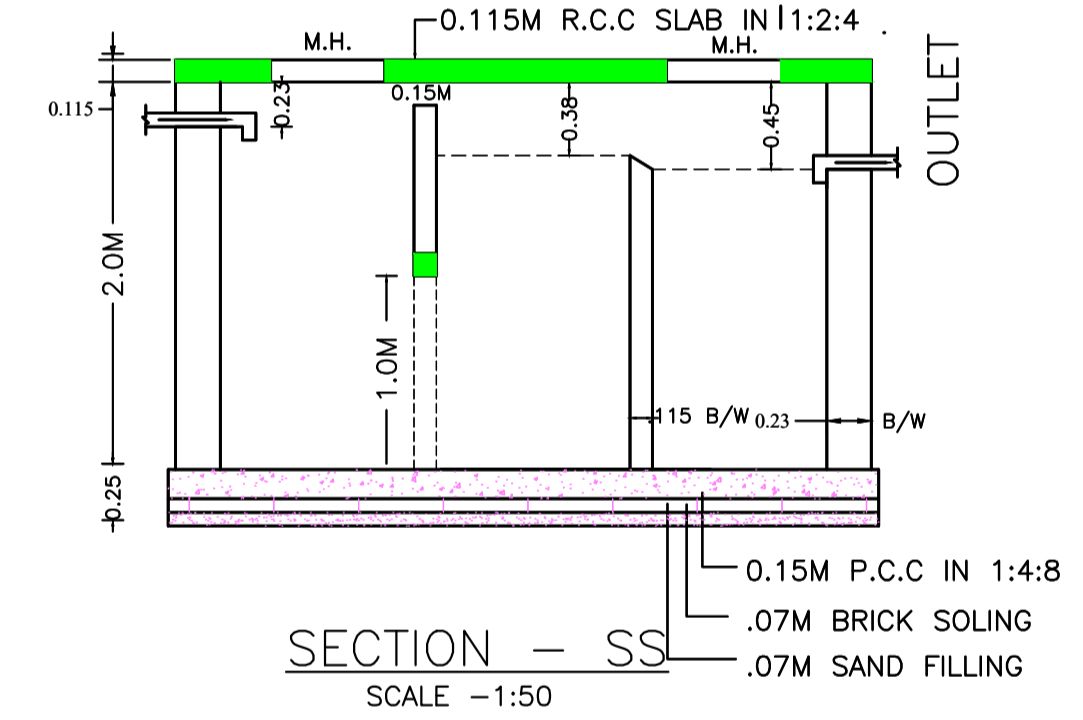

SECTION - SS (SCALE -1:50)

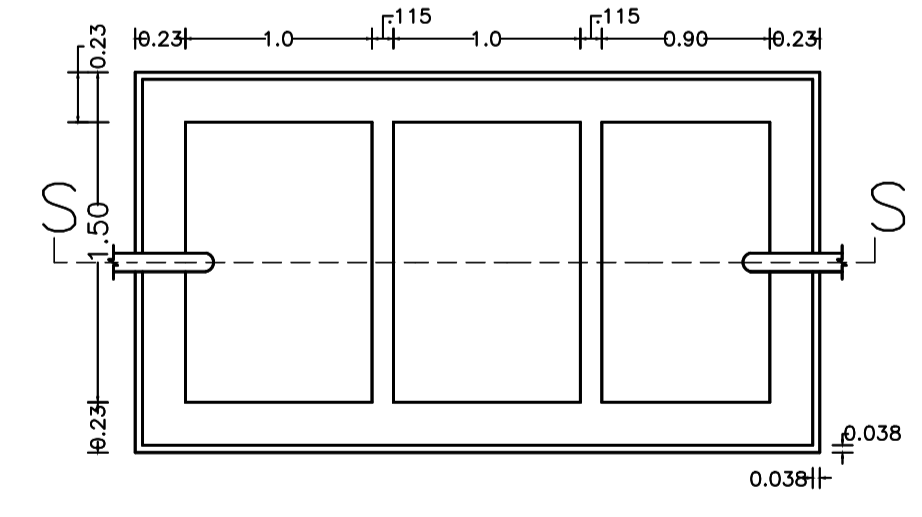

SEPTIC TANK PLAN

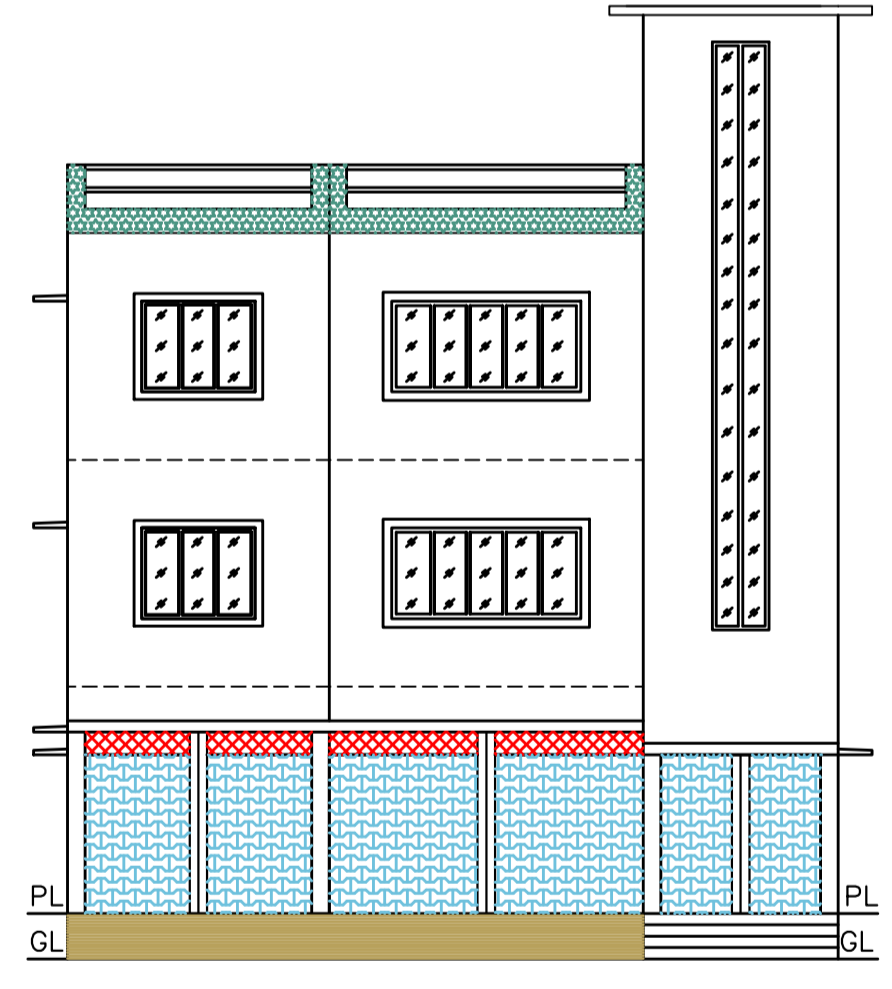

FRONT ELEVATION (SCALE 1:100)

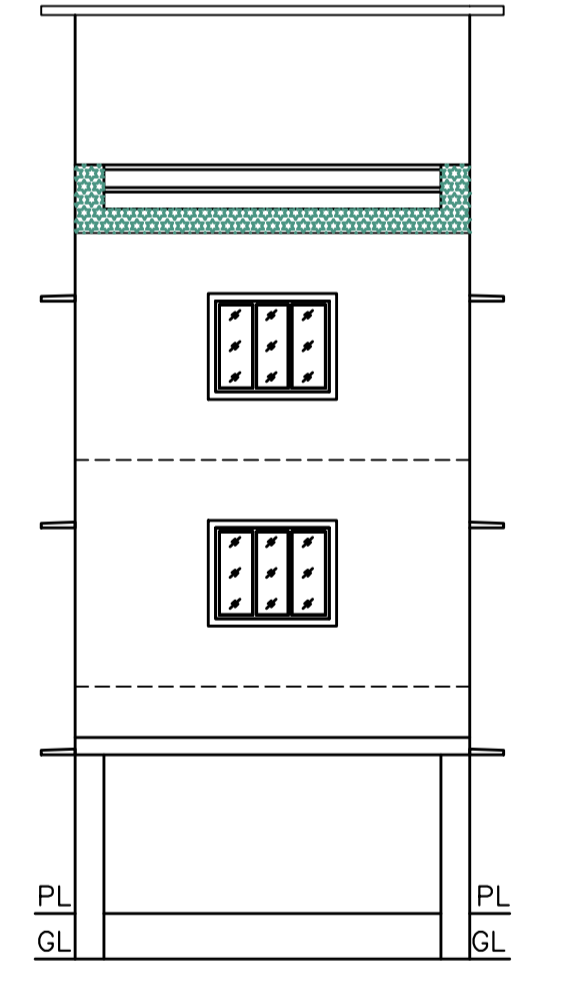

NORTH SIDE ELEVATION (SCALE 1:100)

Building :A (RESIDENTIAL)

Floor Name	Total Built Up Area (Sq.mt.)	Deductions (Area in Sq.mt.)	Proposed FAR Area (Sq.mt.)	Add Area in FAR (Sq.mt.)	Total FAR Area (Sq.mt.)	Total Consumed Additional FAR Area (Sq.mt.)	Trmt (No.)
Ground Floor	53.19	42.64	0.00	10.55	10.55	0.00	00
First Floor	53.19	0.00	53.19	0.00	53.19	53.19	01
Second Floor	53.19	0.00	53.19	0.00	53.19	53.19	00
Terrace Floor	0.00	0.00	0.00	0.00	0.00	0.00	00
Total :	159.57	42.64	106.38	10.55	116.93	116.93	01
Total Number of Same Buildings	1						
Total :	159.57	42.64	106.38	10.55	116.93	116.93	01

SCHEDULE OF DOOR:

BUILDING NAME	NAME	LENGTH	HEIGHT	NOS
A (RESIDENTIAL)	D2	0.75	2.10	02
A (RESIDENTIAL)	D	1.00	2.10	04

SCHEDULE OF WINDOW/VENTILATION:

BUILDING NAME	NAME	LENGTH	HEIGHT	NOS
A (RESIDENTIAL)	V	0.60	0.90	02
A (RESIDENTIAL)	W	1.50	1.20	04
A (RESIDENTIAL)	Wx	2.50	1.20	02

UnitBUA Table for Building :A (RESIDENTIAL)

FLOOR	Name	UnitBUA Type	UnitBUA Area	Carpet Area	No. of Rooms	No. of Tenement
SECOND FLOOR PLAN	SPLIT A	FLAT	0.00	0.00	3	0
FIRST FLOOR PLAN	SPLIT A	FLAT	70.31	68.40	3	1
Total:	-	-	70.31	68.40	6	1

LTP NAME AND SIGNATURE	STRUCTURAL ENG'S NAME AND SIGNATURE	BUILDER NAME AND SIGNATURE	DIGITAL SIGNATURE
Chandrika Sharma MNAC/DFTMN/0017/2017			

Proposal Basic Information	
Proposal File No.	MNAC/BP/0092/W09/2022
Owner Name	MRS. NANDA KUMARI w.o MR. SAILESH YADAV
Khata No	136
Plot No	1523
Village Name	Pardih
Use	Residential
SubUse	Bungalow/ Dwelling / Non Apartment

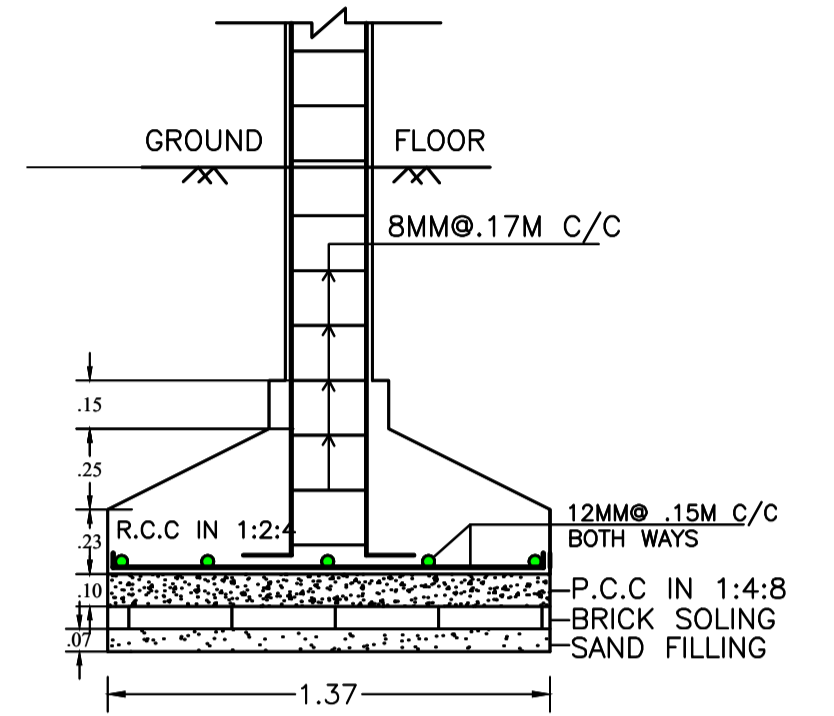

SECTION - CC
SCALE - 1:25

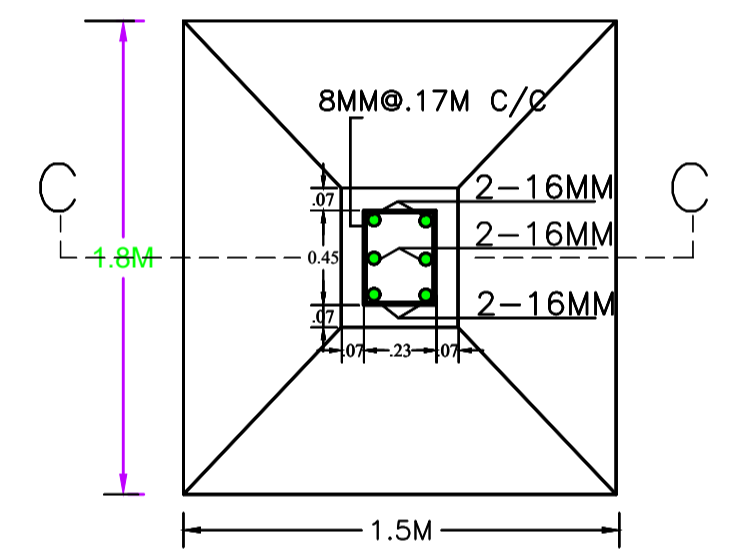

R.C.C. COL. FDN. PLAN
SCALE - 1:25

LTP NAME AND SIGNATURE	STRUCTURAL ENG'S NAME AND SIGNATURE	BUILDER NAME AND SIGNATURE	DIGITAL SIGNATURE
Chandrika Sharma MNAC/DFTMN/0017/2017			