

SITE - PLAN
SCALE 1:100

SITE PLAN

Building USE/SUBUSE Details

Building Name	Building Use	Building SubUse	Building Structure
A (RESIDENTIAL)	Residential	Bungalow/ Dwelling / Non Apartment	Non-Highrise

Proposal Basic Information

Proposal File No	MNAC/BP/0013/W08/2022
Owner Name	MRS SHAZIA ADEEL
Khata No	266
Plot No	3600
Village Name	Pardih
Use	Residential
SubUse	Bungalow/ Dwelling / Non Apartment

FAR & Tenement Details (Table 4c-1)

Building	No. of Same Bldg	Total Built Up Area (Sq.mt.)	Deductions (Area in Sq.mt.)	Proposed FAR Area (Sq.mt.)	Total FAR Area (Sq.mt.)	Total Consumed Additional FAR Area (Sq.mt.)	Tnmt (No.)
A (RESIDENTIAL)	1	265.68	Parking 33.66	232.02	232.02	232.02	01
Grand Total	1	265.68	33.66	232.02	232.02	232.02	01

AREA STATEMENT MANGO MUNICIPAL CORPORATION	VERSION NO.: 1.0.62
	VERSION DATE: 16/10/2020
PROJECT DETAIL:	
Region: JHARKHAND URBAN LOCAL BODIES	Plot Use: Residential
District: EAST SINGHBHUM	Plot SubUse: Bungalow/ Dwelling / Non Apartment
Authority: MANGO MUNICIPAL CORPORATION	Plot/Nearby/Religious/Structure: NA
Inward_No: MNAC/BP/0013/W08/2022	Plot/SubPlot No: 3600
Application Type: General Proposal	North: -
Project Type: Building Permission	South: -
Nature of Development: New	East: -
Location of Development Area: Old Area	West: -
AREA DETAILS:	
AREA OF PLOT (Minimum)	(A) 156.16
NET AREA OF PLOT(Gross Plot Area - Deduction from Gross Plot area)	(A-Deductions) 156.16
Deduction for Balance Plot Area(from Gross Plot Area)	
Common Plot Total	16.20
BALANCE AREA OF PLOT(Net Plot Area - Deductions)	139.96
Recreational/Amenity space	
PLOT AREA FOR COVERAGE(Net Plot Area)	(A-Deductions) 156.16
Plot Area for FAR (Net Plot Area + Road Widening Area)	(A-Deductions) 156.16
COVERAGE CHECK	
Permissible Coverage area (70.00 %)	109.31
Proposed Coverage Area (56.71 %)	88.56
Total Prop. Coverage Area (56.71 %)	88.56
Balance coverage area (13.29 %)	20.75
FAR CHECK	
Perm. FAR Area (1.80)	281.09
Total Perm. FAR area	281.09
Residential FAR	232.02
Proposed FAR Area	232.02
Total Proposed FAR Area	232.02
Consumed FAR (Factor)	1.49
Balance FAR Area	49.07
BUILT UP AREA CHECK	
Total Proposed BuiltUp Area	265.68
ARCHITECT (Regd)	EJAZ AHMAD
ENGINEER (Regd)	
SUPERVISOR (Regd)	
OWNER (Regd)	MRS SHAZIA ADEEL
DEVELOPMENT AUTHORITY	LOCAL BODY

COLOR INDEX	
PLOT BOUNDARY	Black
ABUTTING ROAD	Green
PROPOSED CONSTRUCTION	Red
COMMON PLOT	Yellow
ROAD WIDENING AREA	Blue
EXISTING (To be retained)	Blue
EXISTING (To be demolished)	Yellow

Buildingwise Floor FAR Details

Floor Name	Building Name		Total	
	Proposed Built Up Area (Sq.mt.)	Proposed FAR Area (Sq.mt.)	Total Proposed Built Up Area (Sq.mt.)	Total FAR Area (Sq.mt.)
Ground Floor	88.56	54.90	88.56	54.90
First Floor	88.56	88.56	88.56	88.56
Second Floor	88.56	88.56	88.56	88.56
Terrace Floor	0.00	0.00	0.00	0.00
Total :	265.68	232.02	265.68	232.02

LTP NAME AND SIGNATURE	STRUCTURAL ENG'S NAME AND SIGNATURE	DESIGNER NAME AND SIGNATURE	AUTHOR NAME AND SIGNATURE
EJAZ AHMAD MNAC/DFTMN/0008/2020			

Proposal Basic Information	
Proposal File No	MNAC/BP/0013/W08/2022
Owner Name	MRS SHAZIA ADEEL
Khata No	266
Plot No	3600
Village Name	Pardih
Use	Residential
SubUse	Bungalow/ Dwelling / Non Apartment

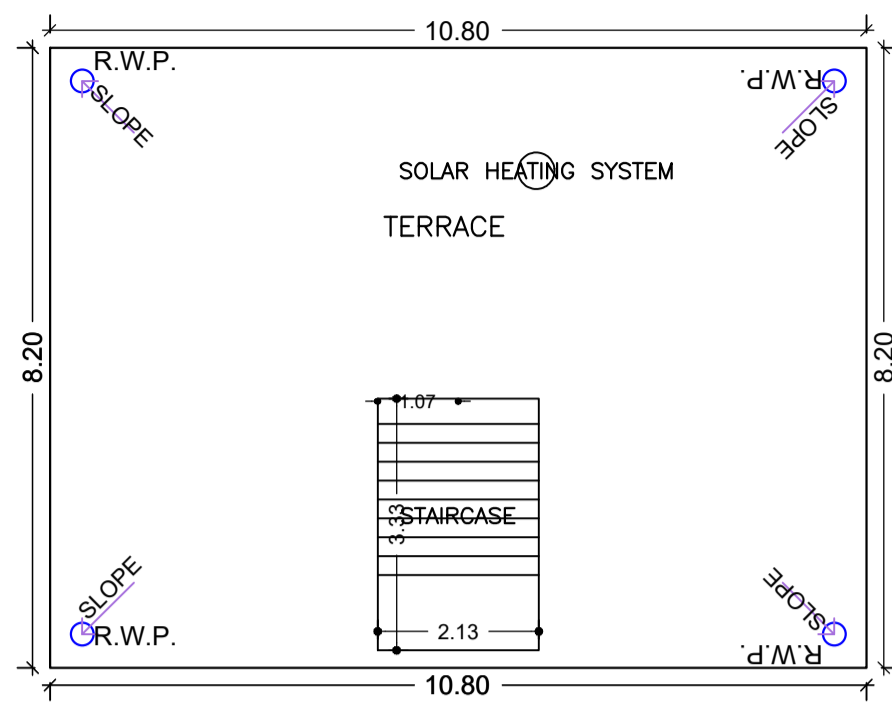
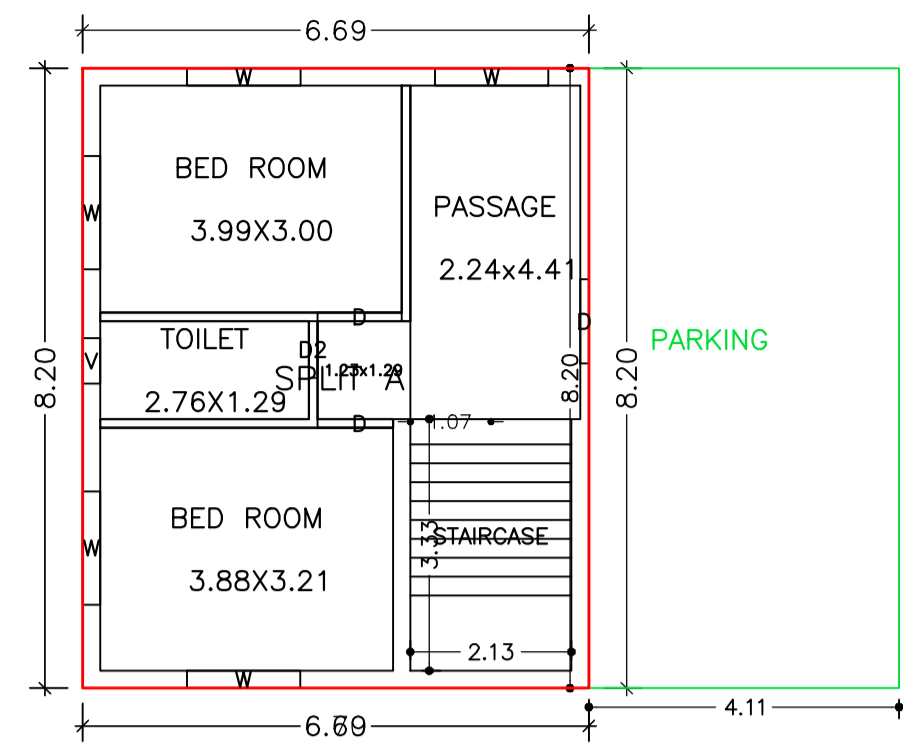

GROUND FLOOR PLAN (Proposed) (SCALE 1:100)

TERRACE FLOOR PLAN (SCALE 1:100)

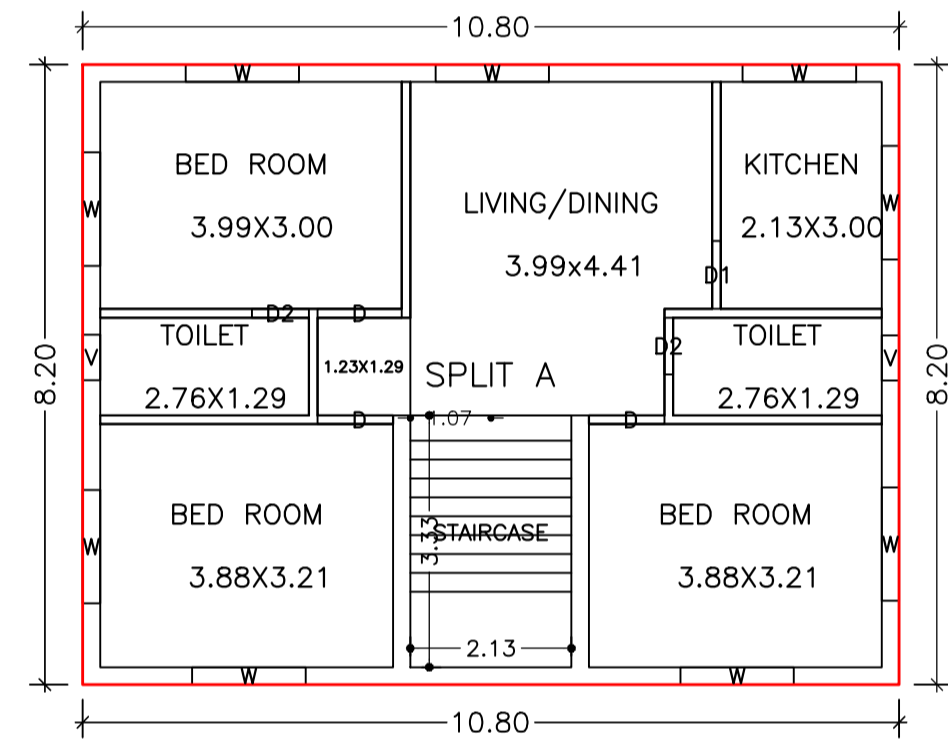

TYPICAL - 1 & 2 FLOOR PLAN (Proposed) (SCALE 1:100)

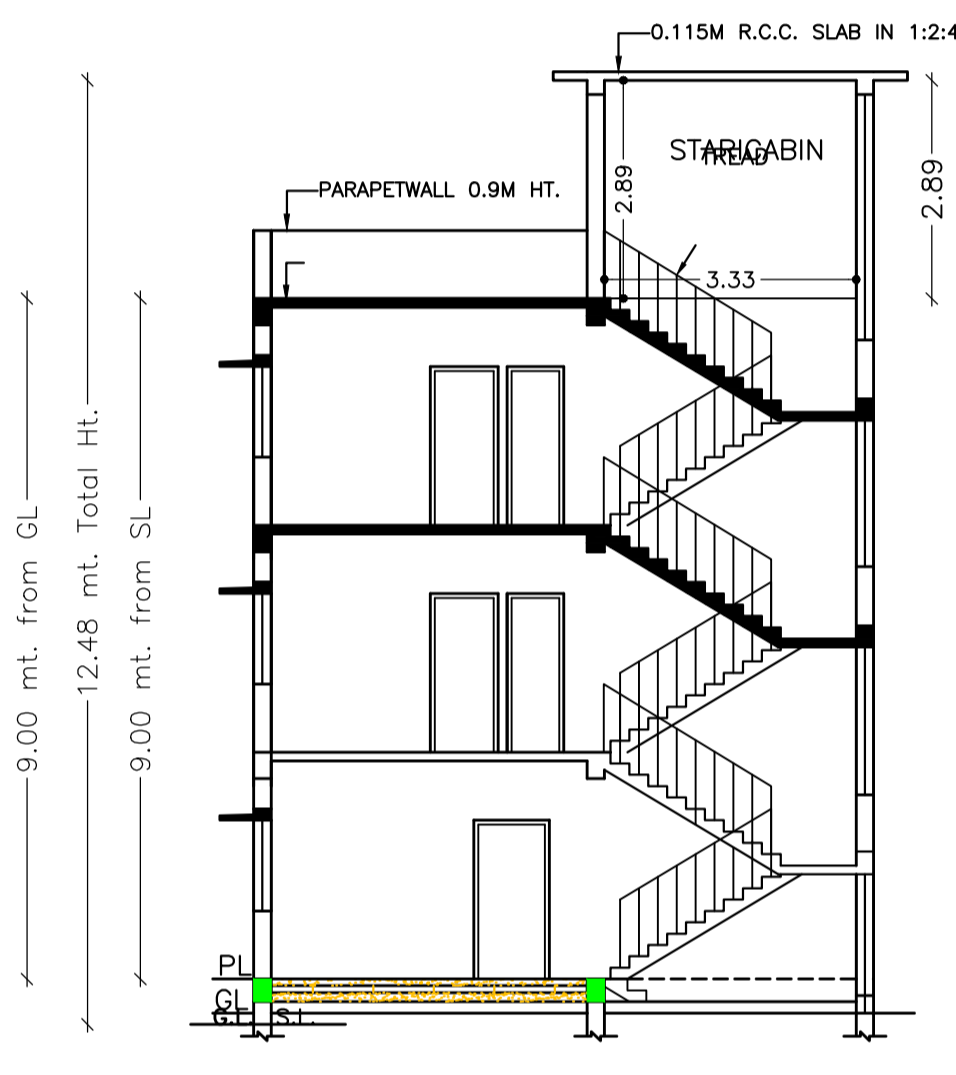

SECTION- AA (SCALE 1:100)

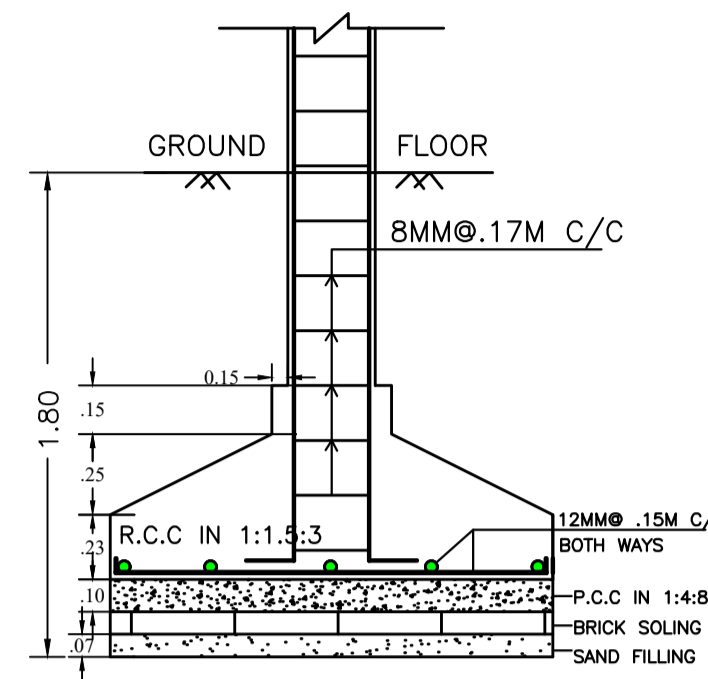
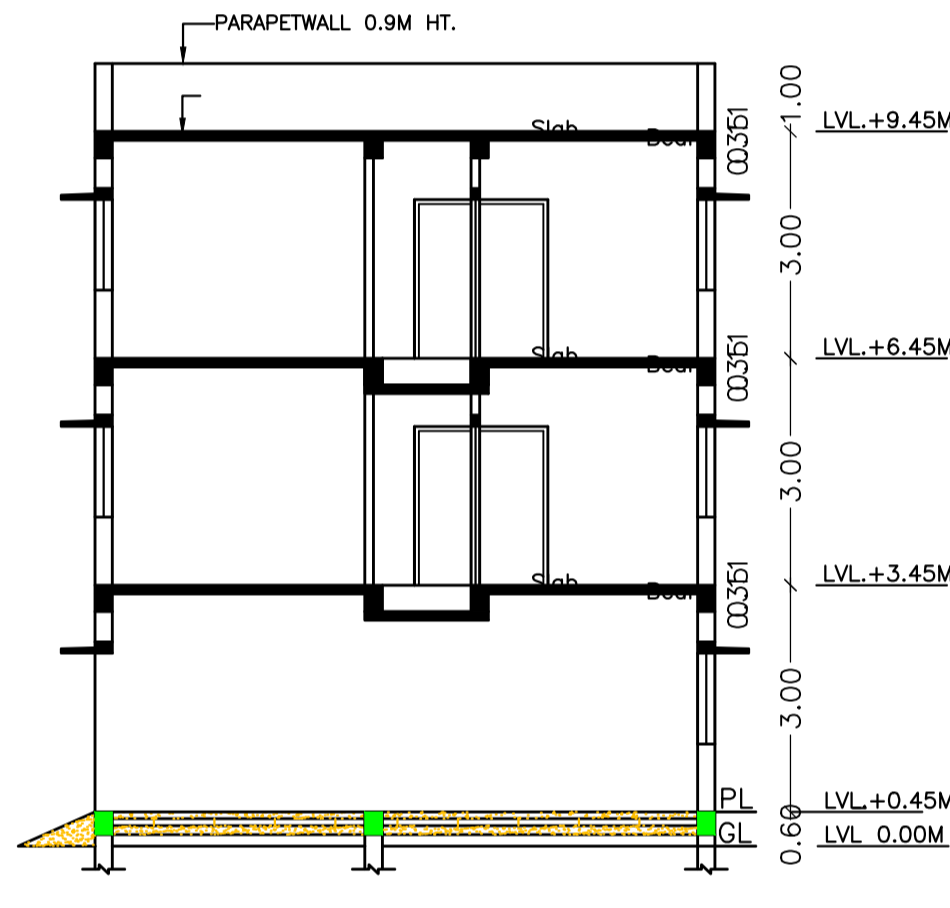

SECTION - CC (SCALE -1:25)

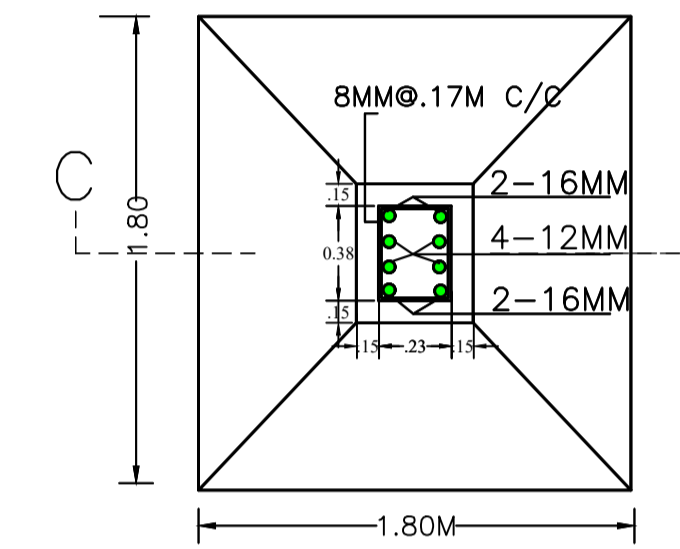

R.C.C. COL. FDN. PLAN (SCALE -1:25)



MOUZA PLAN (NTS)

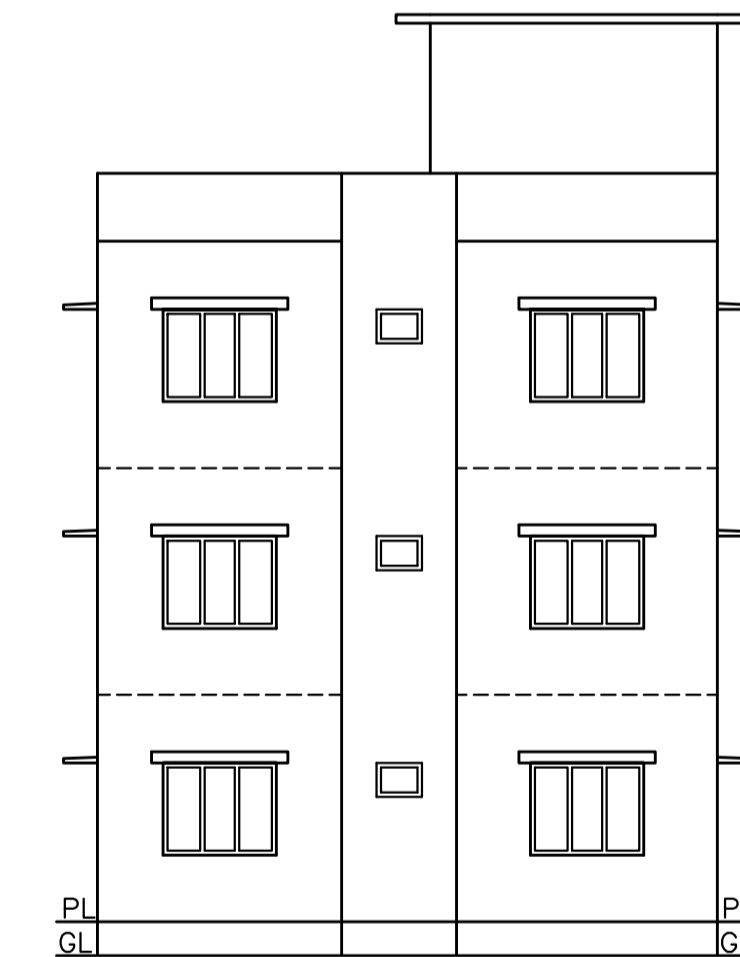

SOUTH SIDE ELEVATION (SCALE 1:100)

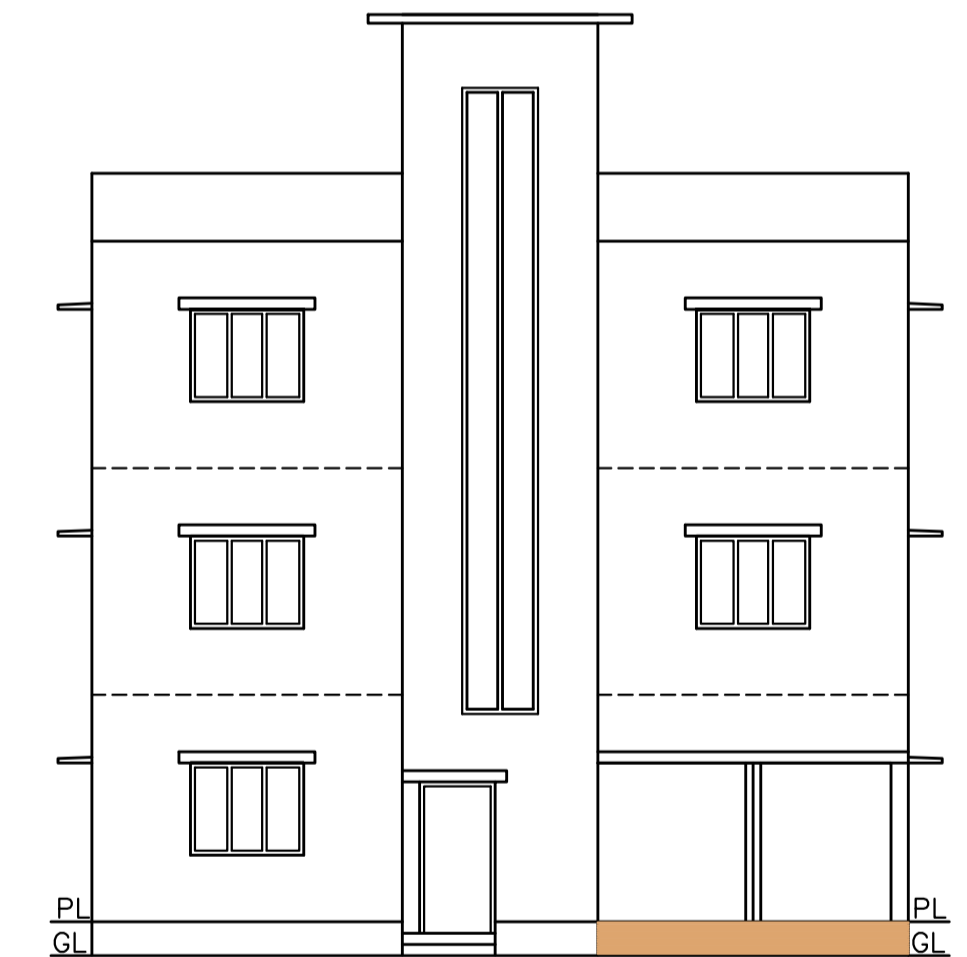

FRONT ELEVATION (SCALE 1:100)

Building :A (RESIDENTIAL)

Floor Name	Total Built Up Area (Sq.mt.)	Deductions (Area in Sq.mt.)	Proposed FAR Area (Sq.mt.)	Total FAR Area (Sq.mt.)	Total Consumed Additional FAR Area (Sq.mt.)	Tnmt (No.)
Ground Floor	88.56	33.66	54.90	54.90	54.90	01
First Floor	88.56	0.00	88.56	88.56	88.56	00
Second Floor	88.56	0.00	88.56	88.56	88.56	00
Terrace Floor	0.00	0.00	0.00	0.00	0.00	00
Total :	265.68	33.66	232.02	232.02	232.02	01
Total Number of Same Buildings :	1					
Total :	265.68	33.66	232.02	232.02	232.02	01

SCHEDULE OF DOOR:

BUILDING NAME	NAME	LENGTH	HEIGHT	NOS
A (RESIDENTIAL)	D2	0.75	2.10	05
A (RESIDENTIAL)	D1	0.90	2.10	02
A (RESIDENTIAL)	D	1.00	2.10	05
A (RESIDENTIAL)	D	1.12	2.10	04

SCHEDULE OF WINDOW/VENTILATION:

BUILDING NAME	NAME	LENGTH	HEIGHT	NOS
A (RESIDENTIAL)	V	0.60	0.90	05
A (RESIDENTIAL)	W	1.50	1.50	23

UnitBUA Table for Building :A (RESIDENTIAL)

FLOOR	Name	UnitBUA Type	UnitBUA Area	Carpet Area	No. of Rooms	No. of Tenement
GROUND FLOOR PLAN	SPLIT A	FLAT	183.72	176.95	4	1
TYPICAL - 1 & 2 FLOOR PLAN	SPLIT A	FLAT	0.00	0.00	7	0
Total:	-	-	183.72	176.95	18	1

LTP NAME AND SIGNATURE	STRUCTURAL ENG'S NAME AND SIGNATURE	SEAL/DERNAME AND SIGNATURE	AUREAL SIGNATURE
EJAZ AHMAD MNAC/DFTMN/0008/2020			

Proposal Basic Information	
Proposal File No	MNAC/BP/0013/W08/2022
Owner Name	MRS SHAZIA ADEEL
Khata No	266
Plot No	3600
Village Name	Pardih
Use	Residential
SubUse	Bungalow/ Dwelling / Non Apartment

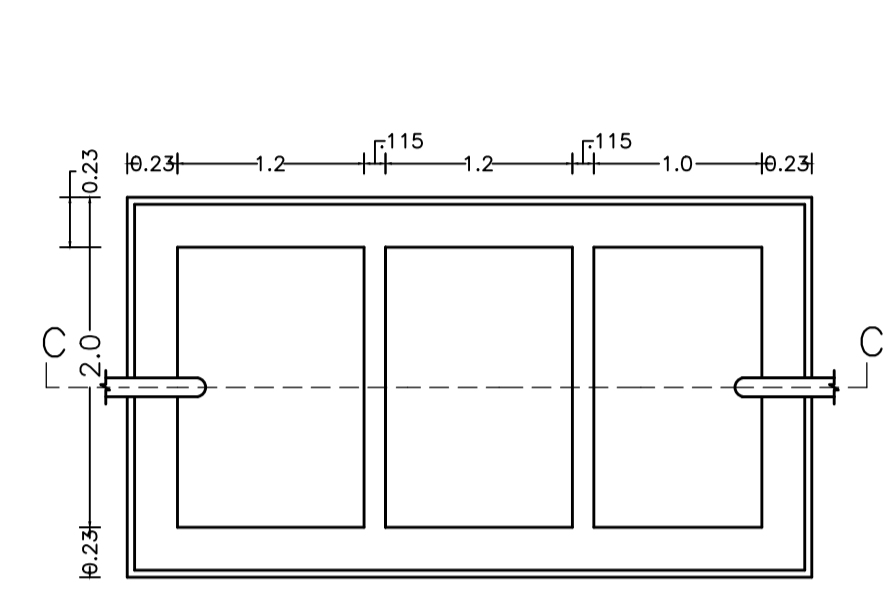

SEPTIC TANK PLAN
SCALE - 1:50

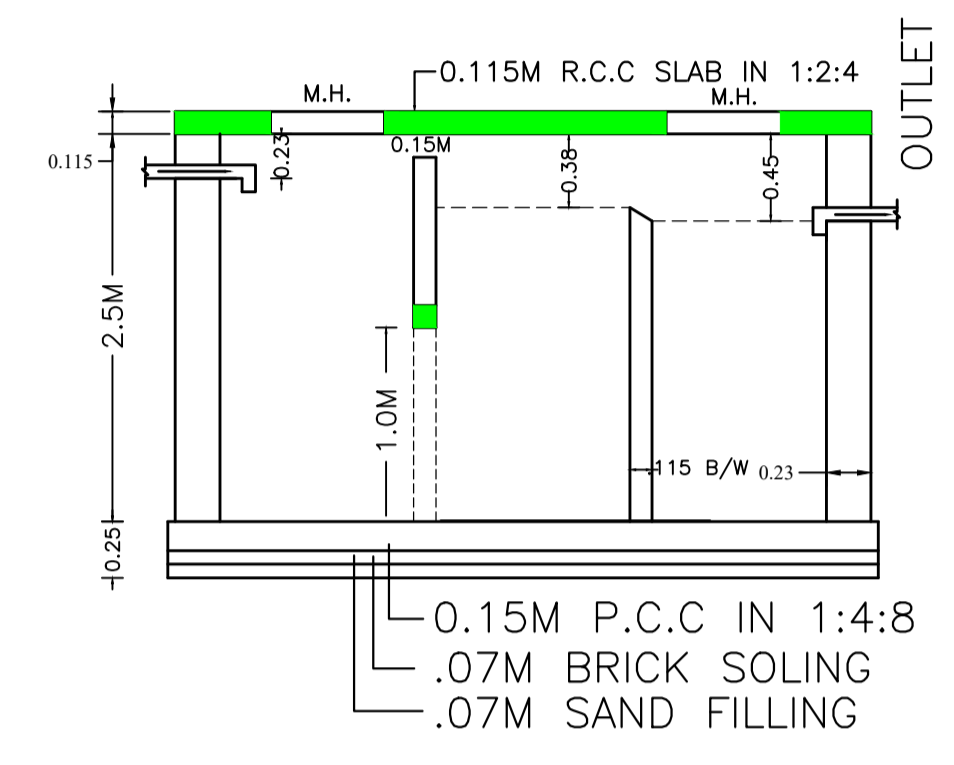

SECTION - SS
SCALE - 1:50

CALCULATION FOR SEPTIC TANK
 TOTAL NOS. OF UNIT = 3 (COM.)
 TOTAL PERSON = 3X5 = 15 PERSONS
 15 PERSONS X 0.085CMT = 1.275 CMT
 1.275+10% EXTRA = 1.40 CMT
 AREA OF SEPTIC TANK PROVIDED
 = 2.0Mx1.5Mx1.5M = 4.50M CMT

CALCULATION OF OVER HEAD WATER TANK
 TOTAL NOS. OF UNIT = 3
 TOTAL PERSON = 3X5 = 15 PERSONS
 15 PERSONS X 135 LTR = 2025.0 LTR
 2025.0 +10% EXTRA = 2227.50 LTR
 AREA OF WATER TANK PROVIDED
 = 2.0Mx1.5Mx1.0M = 3.0 CMT

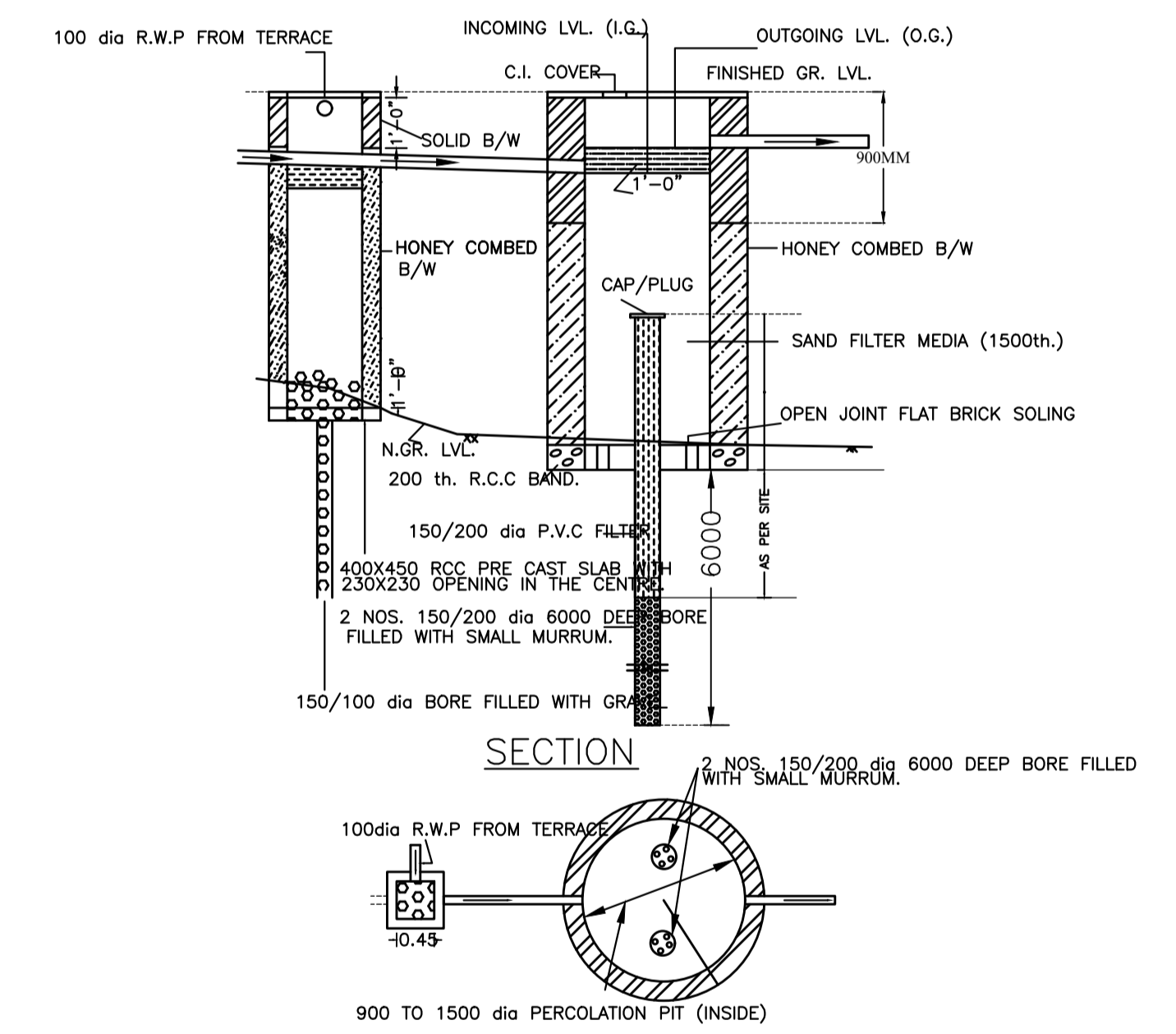

SECTION
WATER HARVESTING PLAN (NTS)

LTP NAME AND SIGNATURE	STRUCTURAL ENG'S NAME AND SIGNATURE	DESIGNER NAME AND SIGNATURE	AUTOMATIC SIGNATURE
EJAZ AHMAD MNAC/DFTMN/0008/2020			