

Proposal Basic Information

Proposal File No.	MNAC/BP/0037/W10/2022
Owner Name	MRS. NANDA DEVI w.o MR. BIJENDRA SHARMA , MR. PAPPU KUMAR s.o MR. BIJENDRA SHARMA
Khata No	425
Plot No	1455
Village Name	Baliguma
Use	Residential
SubUse	Bungalow/ Dwelling / Non Apartment

Buildingwise Floor FAR Details

Floor Name	Building Name A (RESIDENTIAL)		Total	
	Proposed Built Up Area (Sq.mt.)	Proposed FAR Area (Sq.mt.)	Total Proposed Built Up Area (Sq.mt.)	Total FAR Area (Sq.mt.)
Ground Floor	90.29	13.90	90.29	13.90
First Floor	90.29	90.29	90.29	90.29
Terrace Floor	0.00	0.00	0.00	0.00
Total :	180.58	104.19	180.58	104.19

COLOR INDEX	
PLOT BOUNDARY	
ABUTTING ROAD	
PROPOSED CONSTRUCTION	
COMMON PLOT	
ROAD WIDENING AREA	
EXISTING (To be retained)	
EXISTING (To be demolished)	

Building USE/SUBUSE Details

Building Name	Building Use	Building SubUse	Building Structure
A (RESIDENTIAL)	Residential	Bungalow/ Dwelling / Non Apartment	Non-Highrise

FAR & Tenement Details (Table 4c-1)

Building	No. of Same Bldg	Total Built Up Area (Sq.mt.)	Deductions (Area in Sq.mt.)	Proposed FAR Area (Sq.mt.)	Add Area In FAR (Sq.mt.)	Total FAR Area (Sq.mt.)	Total Consumed Additional FAR Area (Sq.mt.)	Tnmt (No.)
A (RESIDENTIAL)	1	180.58	76.39	94.40	9.79	104.19	104.19	01
Grand Total :	1	180.58	76.39	94.40	9.79	104.19	104.19	01

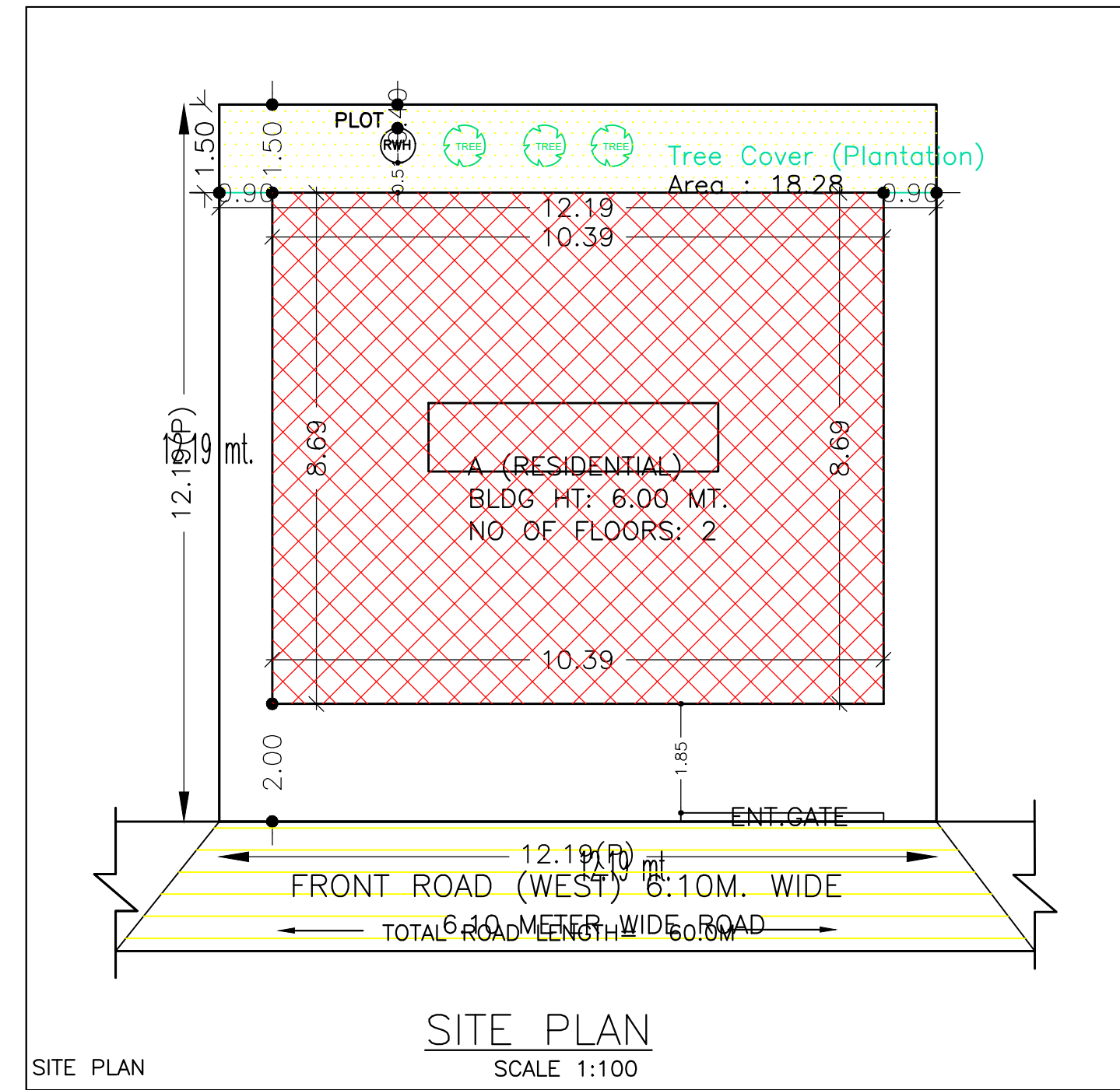

SITE PLAN SCALE 1:100

AREA STATEMENT MANGO MUNICIPAL CORPORATION	VERSION NO.: 1.0.64	
PROJECT DETAIL:	VERSION DATE: 16/10/2020	
Region: JHARKHAND URBAN LOCAL BODIES	Plot Use: Residential	
District: EAST SINGHBHUM	Plot SubUse: Bungalow/ Dwelling / Non Apartment	
Authority: MANGO MUNICIPAL CORPORATION	PlotNearbyReligiousStructure: NA	
Inward_No: MNAC/BP/0037/W10/2022	Plot/SubPlot No: 1455	
Application Type: General Proposal	North: Plot No. - 1452	
Project Type: Building Permission	South: Plot No. - 1456	
Nature of Development: New	East: Plot No. - 1455	
Location of Development Area: Old Area	West: Road Width - 6.10	
AREA DETAILS:	SQ.MT.	
AREA OF PLOT (Minimum)	(A)	148.60
NET AREA OF PLOT (Gross Plot Area - Deduction from Gross Plot area)	(A-Deductions)	148.60
Deduction for Balance Plot Area (from Gross Plot Area)		
Common Plot		18.29
Total		18.29
BALANCE AREA OF PLOT (Net Plot Area)	(A-Deductions)	130.31
Recreational/Amenity space		
PLOT AREA FOR COVERAGE (Net Plot Area)	(A-Deductions)	148.60
Plot Area for FAR (Net Plot Area + Road Widening Area)	(A-Deductions)	148.60
COVERAGE CHECK		
Permissible Coverage area (70.00 %)		104.02
Proposed Coverage Area (60.76 %)		90.29
Total Prop. Coverage Area (60.76 %)		90.29
Balance coverage area (9.24 %)		13.73
FAR CHECK		
Perm. FAR Area (2.500)		371.50
Total Perm. FAR area		371.50
Residential FAR		94.40
Proposed FAR Area		104.19
Total Proposed FAR Area		104.19
Consumed FAR (Factor)		0.70
Balance FAR Area		267.31
BUILT UP AREA CHECK		
Total Proposed BuiltUp Area		180.58
ARCHITECT (Regd)		Chandrika Sharma
ENGINEER (Regd)		
SUPERVISOR (Regd)		
OWNER (Regd)		MRS. NANDA DEVI w.o MR. BIJENDRA SHARMA , MR. PAPPU KUMAR s.o MR. BIJENDRA SHARMA
DEVELOPMENT AUTHORITY		LOCAL BODY

LTP NAME AND SIGNATURE	STRUCTURAL ENG'S NAME AND SIGNATURE	DESIGNER NAME AND SIGNATURE	REAL SIGNATURE
Chandrika Sharma MNAC/DFTMN/0017/2017			

Proposal Basic Information	
Proposal File No	MNAC/BP/0037/W10/2022
Owner Name	MRS. NANDA DEVI w.o MR. BIJENDRA SHARMA , MR. PAPPU KUMAR s.o MR. BIJENDRA SHARMA
Khata No	425
Plot No	1455
Village Name	Baliguma
Use	Residential
SubUse	Bungalow/ Dwelling / Non Apartment

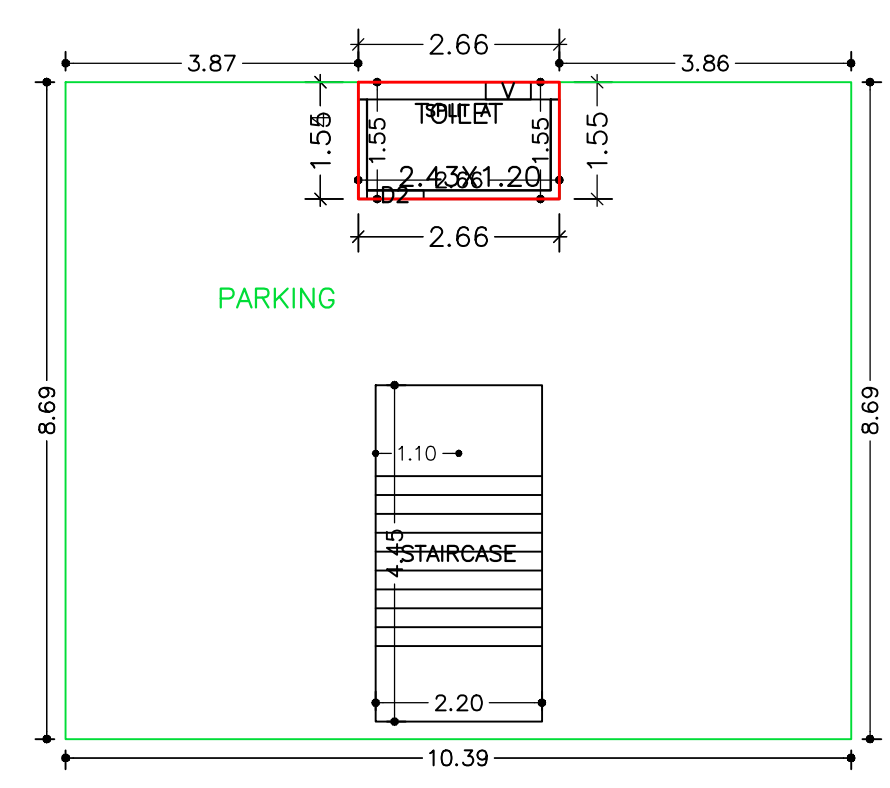

GROUND FLOOR PLAN
(Proposed)
(SCALE 1:100)

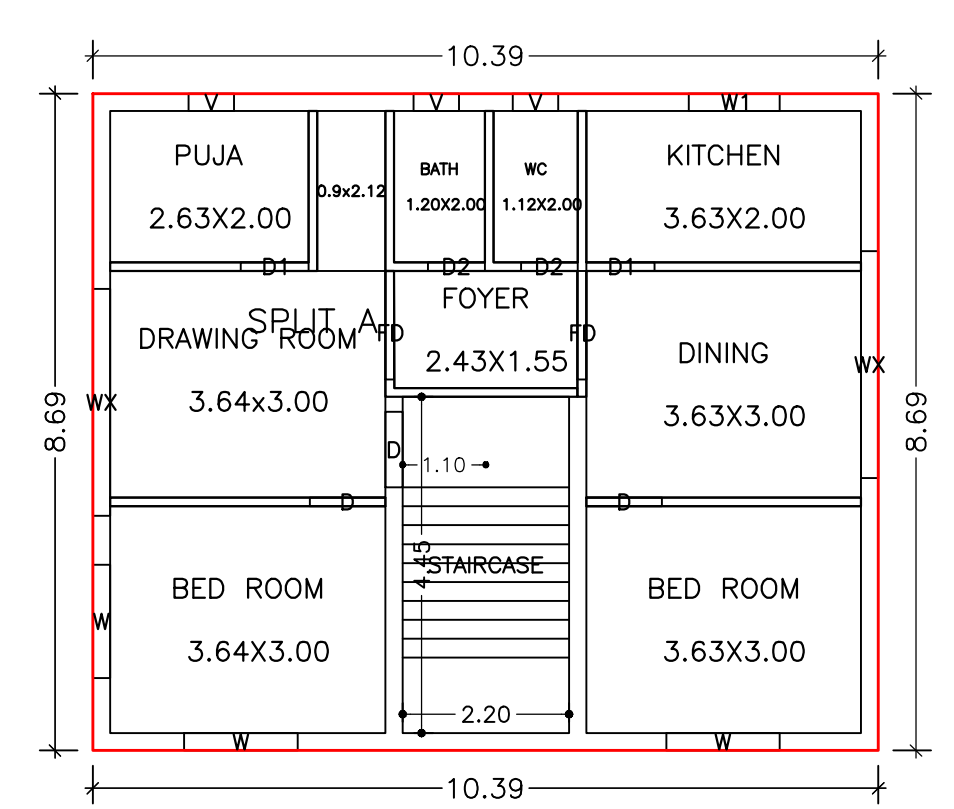

FIRST FLOOR PLAN
(Proposed)
(SCALE 1:100)

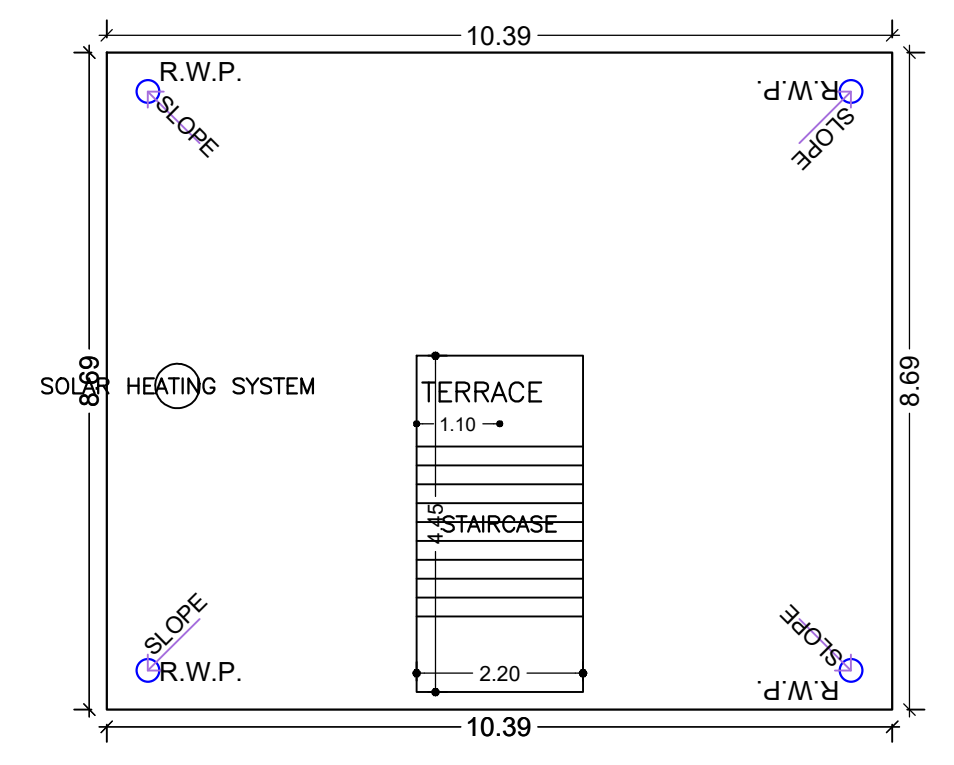

TERRACE FLOOR PLAN
(SCALE 1:100)

Building :A (RESIDENTIAL)

Floor Name	Total Built Up Area (Sq.mt.)	Deductions (Area in Sq.mt.)		Proposed FAR Area (Sq.mt.)	Add Area In FAR (Sq.mt.)	Total FAR Area (Sq.mt.)	Total Consumed Additional FAR Area (Sq.mt.)	Tnmt (No.)
		Parking	Resi.					
Ground Floor	90.29	76.39	4.11	9.79	13.90	13.90	01	
First Floor	90.29	0.00	90.29	0.00	90.29	90.29	00	
Terrace Floor	0.00	0.00	0.00	0.00	0.00	0.00	00	
Total :	180.58	76.39	94.40	9.79	104.19	104.19	01	
Total Number of Same Buildings :	1							
Total :	180.58	76.39	94.40	9.79	104.19	104.19	01	

SCHEDULE OF DOOR:

BUILDING NAME	NAME	LENGTH	HEIGHT	NOS
A (RESIDENTIAL)	D2	0.75	2.10	03
A (RESIDENTIAL)	D1	0.90	2.10	02
A (RESIDENTIAL)	D	1.00	2.10	03
A (RESIDENTIAL)	FD	1.44	2.10	02

SCHEDULE OF WINDOW/VENTILATION:

BUILDING NAME	NAME	LENGTH	HEIGHT	NOS
A (RESIDENTIAL)	V	0.60	0.90	04
A (RESIDENTIAL)	W1	1.20	1.20	01
A (RESIDENTIAL)	W	1.50	1.20	03
A (RESIDENTIAL)	WX	3.00	1.20	02

UnitBUA Table for Building :A (RESIDENTIAL)

FLOOR	Name	UnitBUA Type	UnitBUA Area	Carpet Area	No. of Rooms	No. of Tenement
GROUND FLOOR PLAN	SPLIT A	FLAT	73.38	69.34	1	1
FIRST FLOOR PLAN	SPLIT A	FLAT	0.00	0.00	9	0
Total:	-	-	73.38	69.34	10	1

LTP NAME AND SIGNATURE	STRUCTURAL ENG'S NAME AND SIGNATURE	SENDER NAME AND SIGNATURE	RECEIVER NAME AND SIGNATURE
Chandrika Sharma MNAC/DFTMN/0017/2017			

Proposal Basic Information	
Proposal File No	MNAC/BP/0037/W10/2022
Owner Name	MRS. NANDA DEVI w.o MR. BIJENDRA SHARMA , MR. PAPPU KUMAR s.o MR. BIJENDRA SHARMA
Khata No	425
Plot No	1455
Village Name	Baliguma
Use	Residential
SubUse	Bungalow/ Dwelling / Non Apartment

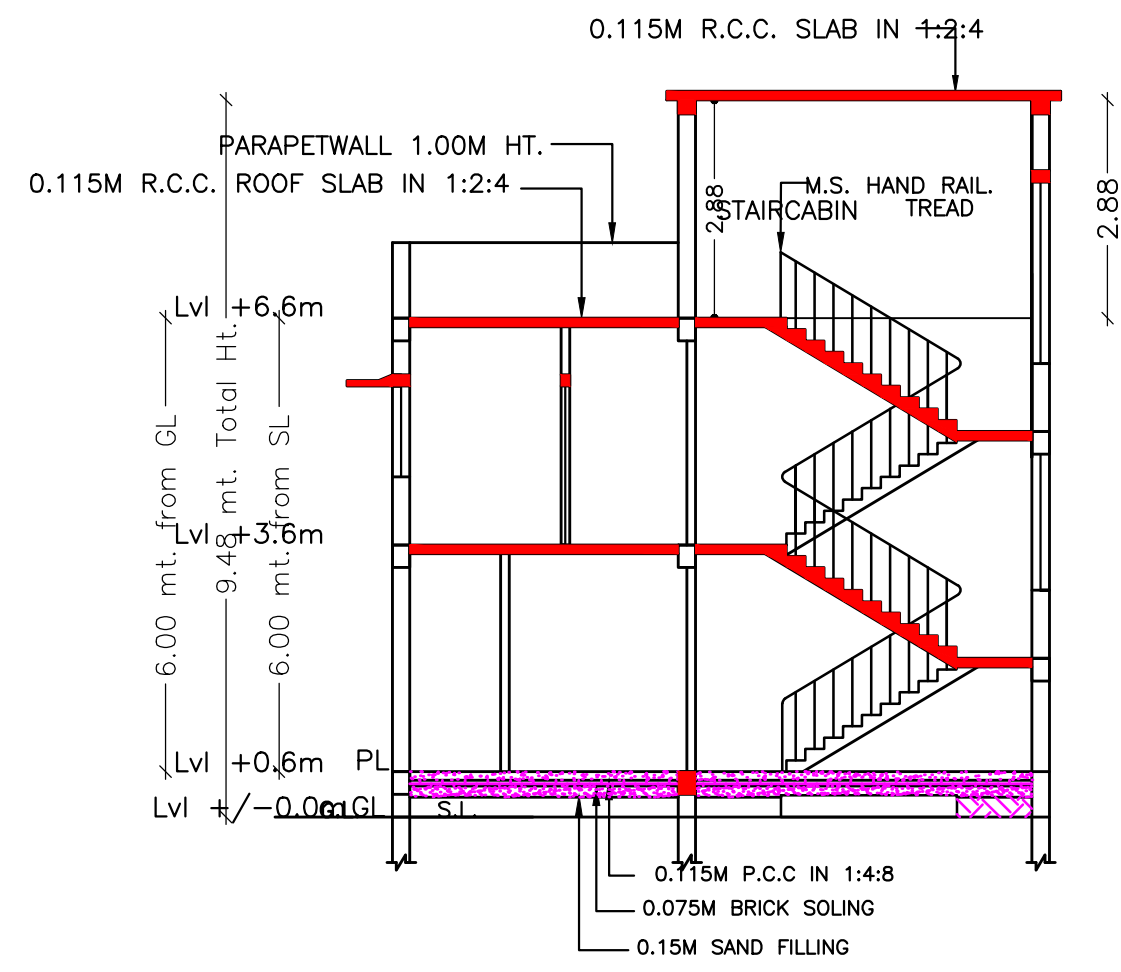

SECTION - A A

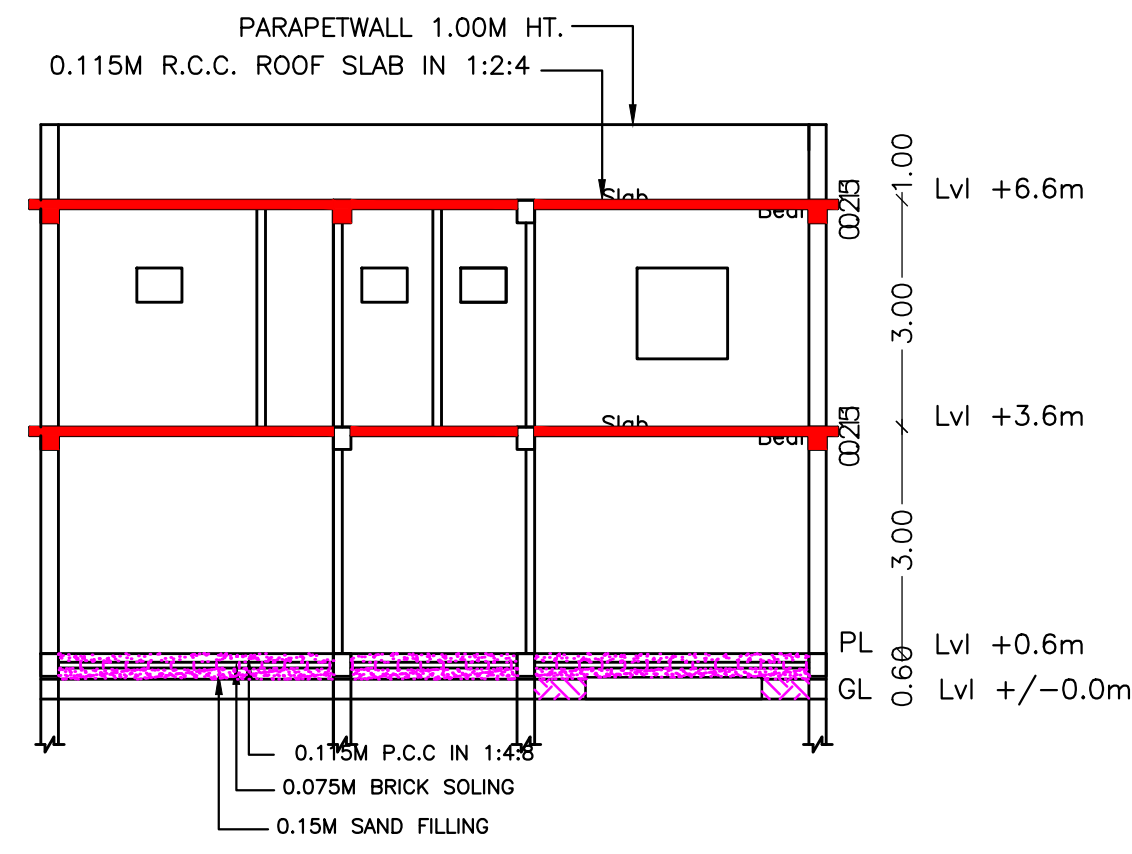

SECTION - B B
SCALE 1:100

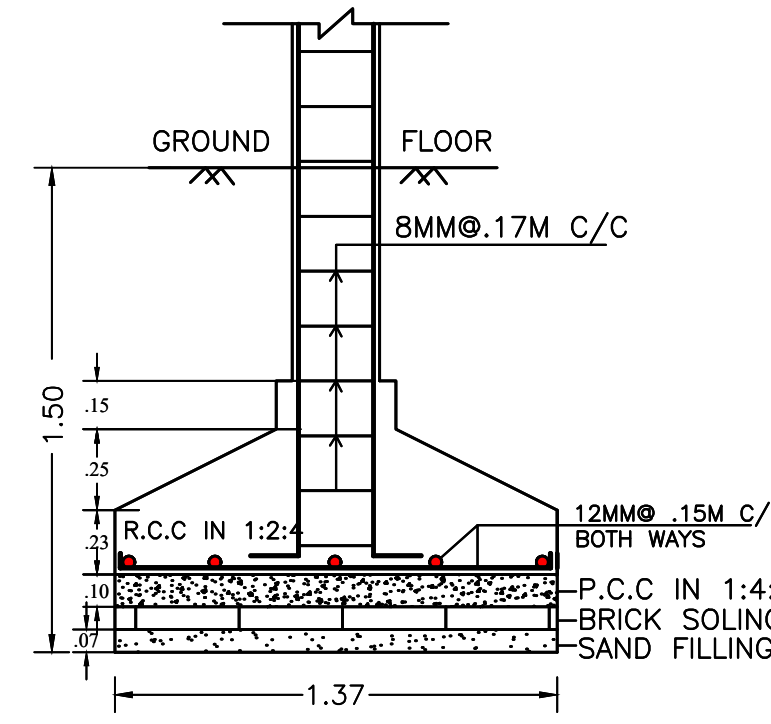

SECTION - CC
SCALE -1:25

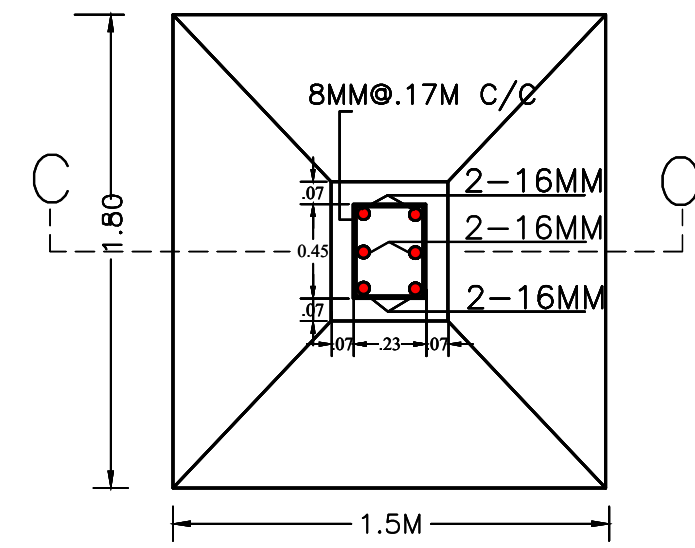
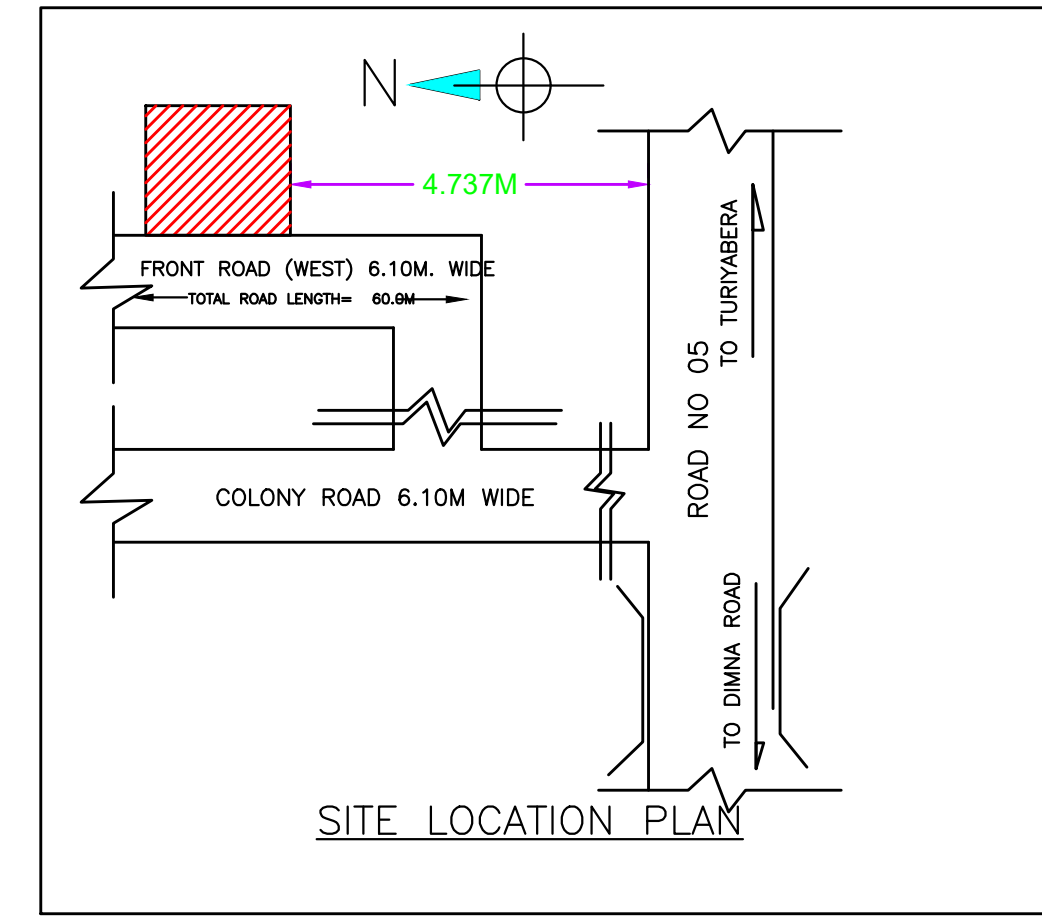

R.C.C. COL. FDN. PLAN
SCALE -1:25

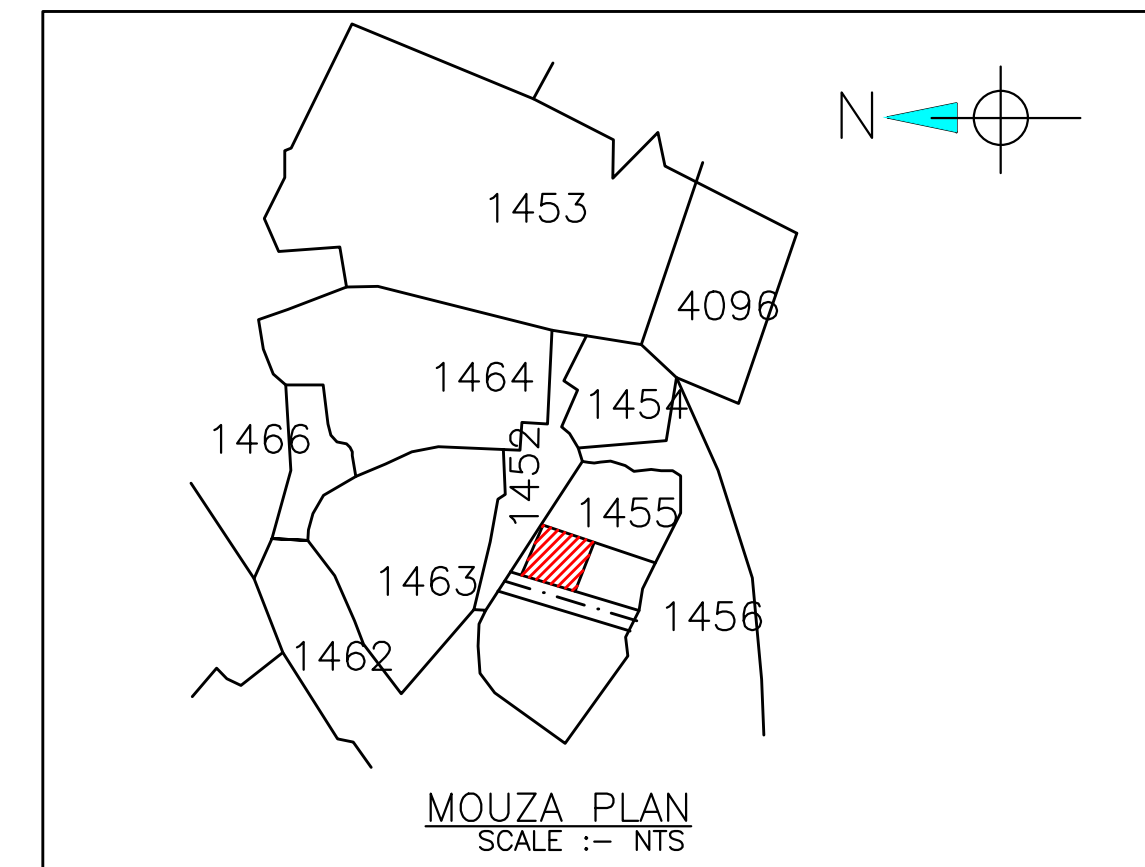

MOUZA PLAN
SCALE :- NTS

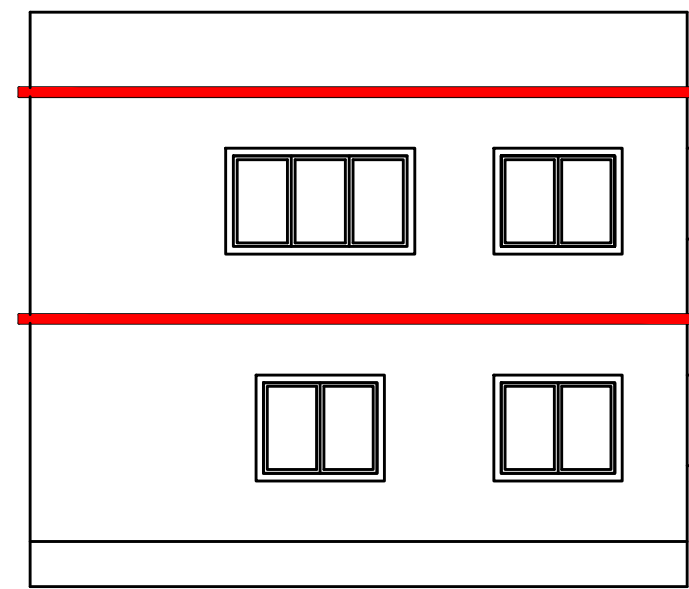

SIDE ELEVATION
SCALE 1:100

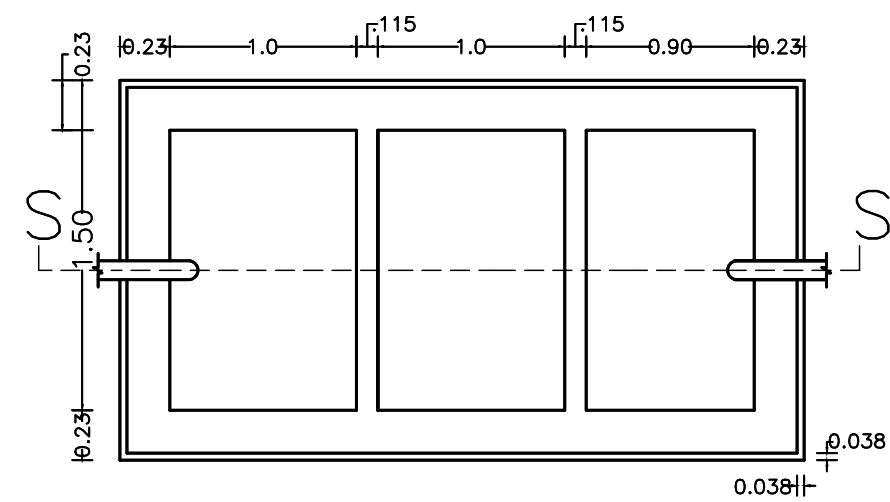

SEPTIC TANK PLAN

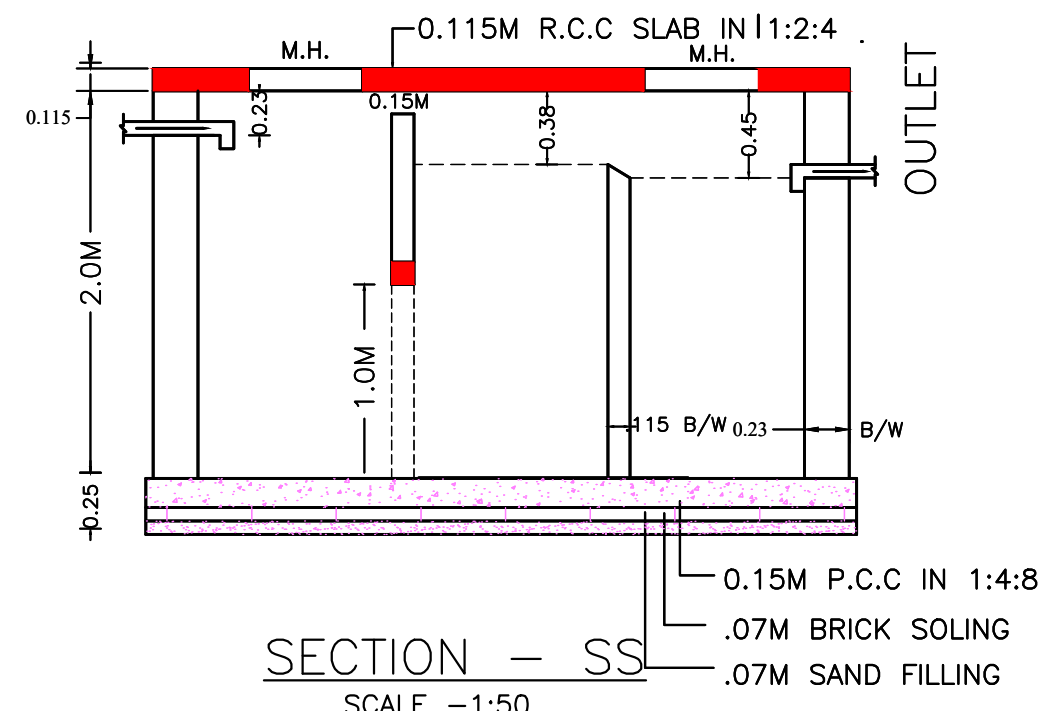

SECTION - SS
SCALE -1:50

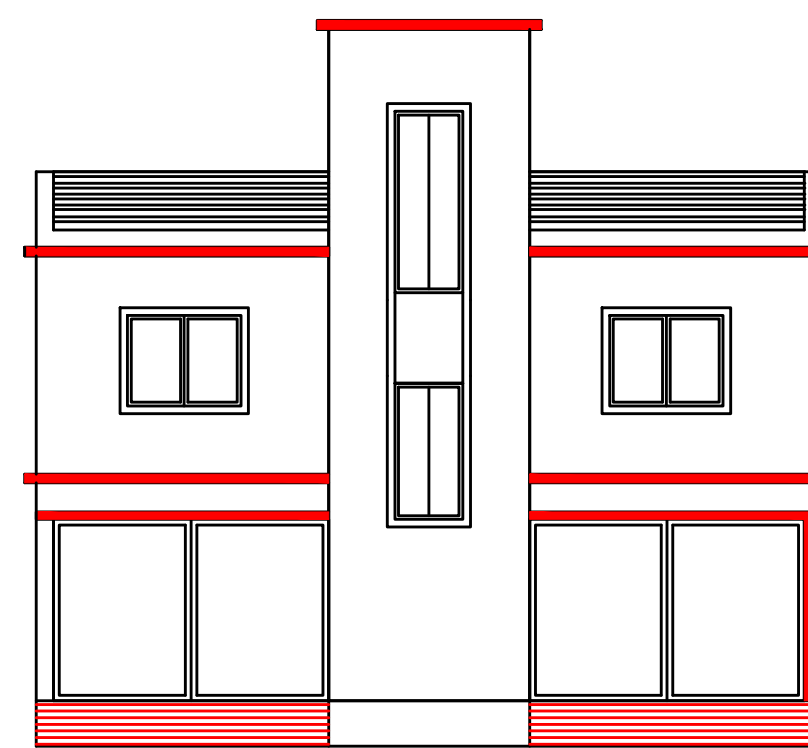

FRONT ELEVATION
SCALE 1:100

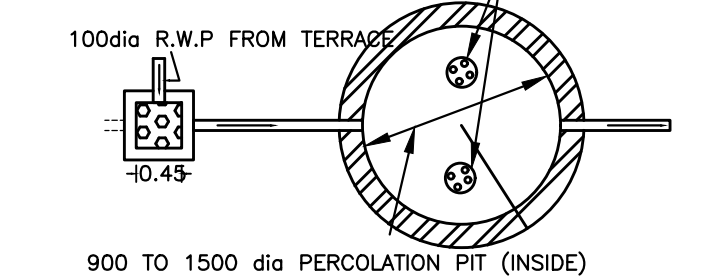
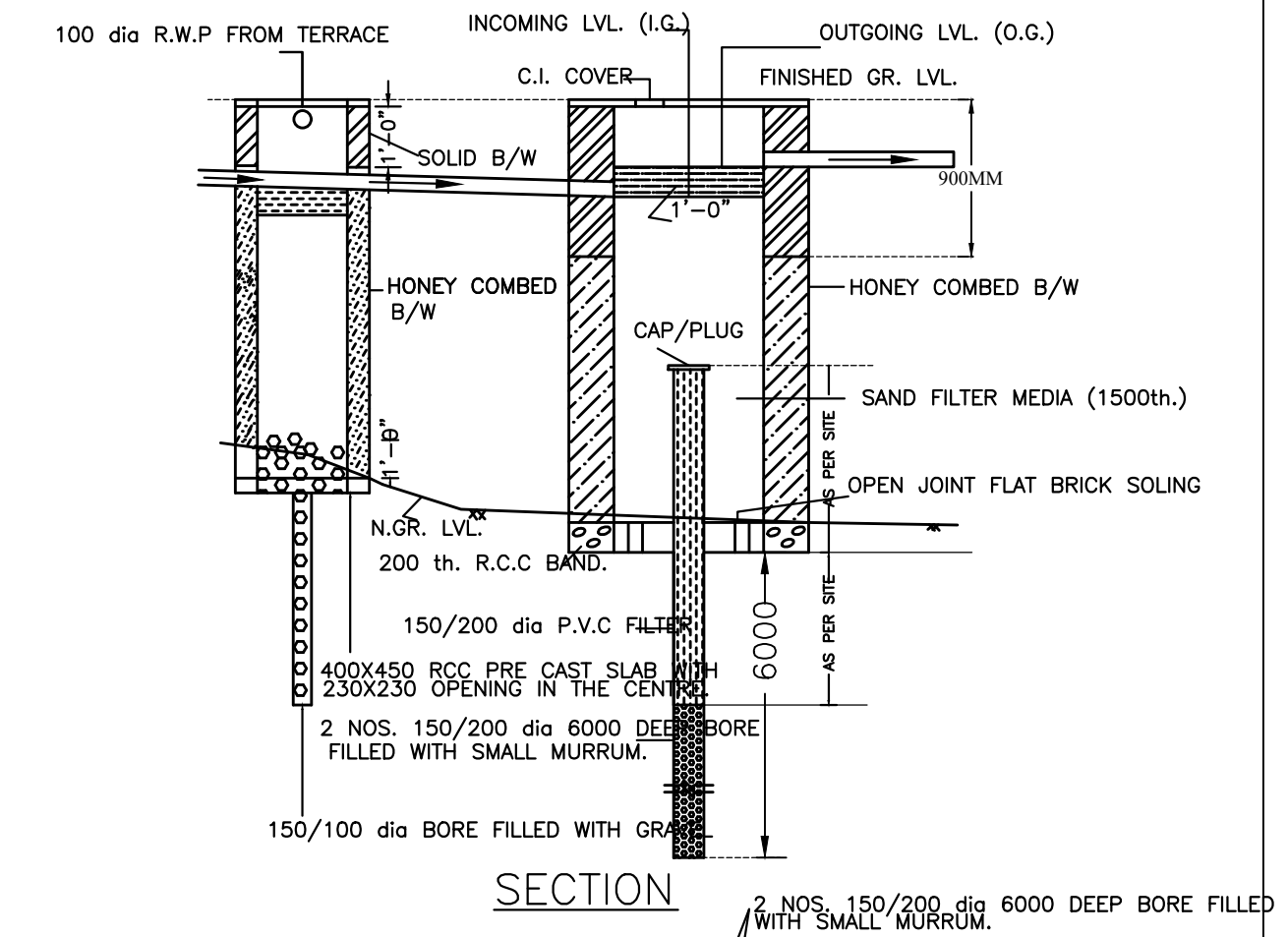

WATER HARVESTING PLAN (NTS)

LTP NAME AND SIGNATURE	STRUCTURAL ENG'S NAME AND SIGNATURE	DESIGNER NAME AND SIGNATURE	AUDITOR NAME AND SIGNATURE
Chandrika Sharma MNAC/DFTMN/0017/2017			