

SITE PLAN

FAR & Tenement Details (Table 4c-1)

Building	No. of Same Bldg	Total Built Up Area (Sq.mt.)	Deductions (Area in Sq.mt.)		Proposed FAR Area (Sq.mt.)	Total FAR Area (Sq.mt.)	Total Consumed Additional FAR Area (Sq.mt.)	Trmnt (No.)
			Lift	Parking				
A (RESIDENTIAL)	1	507.96	9.69	61.33	436.94	436.94	436.94	01
Grand Total :	1	507.96	9.69	61.33	436.94	436.94	436.94	01

Proposal Basic Information

Proposal File No.	MNAC/BP/0036/W09/2022
Owner Name	DR. SHRI MANOJ KUMAR
Khata No	311
Plot No	1405
Village Name	Dimna
Use	Residential
SubUse	Bungalow/ Dwelling / Non Apartment

AREA STATEMENT MANGO MUNICIPAL CORPORATION		VERSION NO: 1.0.64
		VERSION DATE: 16/10/2020
PROJECT DETAIL:		
Region: JHARKHAND URBAN LOCAL BODIES	Plot Use: Residential	
District: EAST SINGHBHUM	Plot SubUse: Bungalow/ Dwelling / Non Apartment	
Authority: MANGO MUNICIPAL CORPORATION	PlotNearbyReligiousStructure: NA	
Inward No: MNAC/BP/0036/W09/2022	PlotSubPlot No: 1405	
Application Type: General Proposal	North: -	
Project Type: Building Permission	South: -	
Nature of Development: New	East: -	
Location of Development Area: Old Area	West: -	
AREA DETAILS:		
AREA OF PLOT (Minimum)	(A)	SQ.MT. 249.59
NET AREA OF PLOT(Gross Plot Area - Deduction from Gross Plot area)	(A-Deductions)	249.59
Deduction for Balance Plot Area(from Gross Plot Area)		
Common Plot		36.55
Total		36.55
BALANCE AREA OF PLOT(Net Plot Area - Recreational/Amenity space)	(A-Deductions)	213.04
PLOT AREA FOR COVERAGE(Net Plot Area)	(A-Deductions)	249.59
Plot Area for FAR (Net Plot Area + Road Widening Area)	(A-Deductions)	249.59
COVERAGE CHECK		
Permissible Coverage area (60.00 %)		149.75
Proposed Coverage Area (50.57 %)		126.21
Total Prop. Coverage Area (50.57 %)		126.21
Balance coverage area (9.43 %)		23.54
FAR CHECK		
Perm. FAR Area (2.500)		623.97
Total Perm. FAR area		623.97
Residential FAR		436.94
Proposed FAR Area		436.94
Total Proposed FAR Area		436.94
Consumed FAR (Factor)		1.75
Balance FAR Area		187.03
BUILT UP AREA CHECK		
Total Proposed BuiltUp Area		507.96
ARCHITECT (Regd)	EJAZ AHMAD	
ENGINEER (Regd)		
SUPERVISOR (Regd)		
OWNER (Regd)	DR. SHRI MANOJ KUMAR	
DEVELOPMENT AUTHORITY		LOCAL BODY

COLOR INDEX	
PLOT BOUNDARY	
ABUTTING ROAD	
PROPOSED CONSTRUCTION	
COMMON PLOT	
ROAD WIDENING AREA	
EXISTING (To be retained)	
EXISTING (To be demolished)	

Buildingwise Floor FAR Details

Floor Name	Building Name A (RESIDENTIAL)		Total	
	Proposed Built Up Area (Sq.mt.)	Proposed FAR Area (Sq.mt.)	Total Proposed Built Up Area (Sq.mt.)	Total FAR Area (Sq.mt.)
Ground Floor	126.21	64.88	126.21	64.88
First Floor	127.25	124.02	127.25	124.02
Second Floor	127.25	124.02	127.25	124.02
Third Floor	127.25	124.02	127.25	124.02
Terrace Floor	0.00	0.00	0.00	0.00
Total :	507.96	436.94	507.96	436.94

Building USE/SUBUSE Details

Building Name	Building Use	Building SubUse	Building Structure
A (RESIDENTIAL)	Residential	Bungalow/ Dwelling / Non Apartment	Non-Highrise

LTP NAME AND SIGNATURE	STRUCTURAL ENG'S NAME AND SIGNATURE	BUILDER NAME AND SIGNATURE	DIGITAL SIGNATURE
EJAZ AHMAD MNAC/DFTMN/0008/2020			

DATE 28-11-2022 SHEET NO. 2	
Proposal Basic Information	
Proposal File No.	MNAC/BP/0036/W09/2022
Owner Name	DR. SHRI MANOJ KUMAR
Khata No	311
Plot No	1405
Village Name	Dimna
Use	Residential
SubUse	Bungalow/ Dwelling / Non Apartment

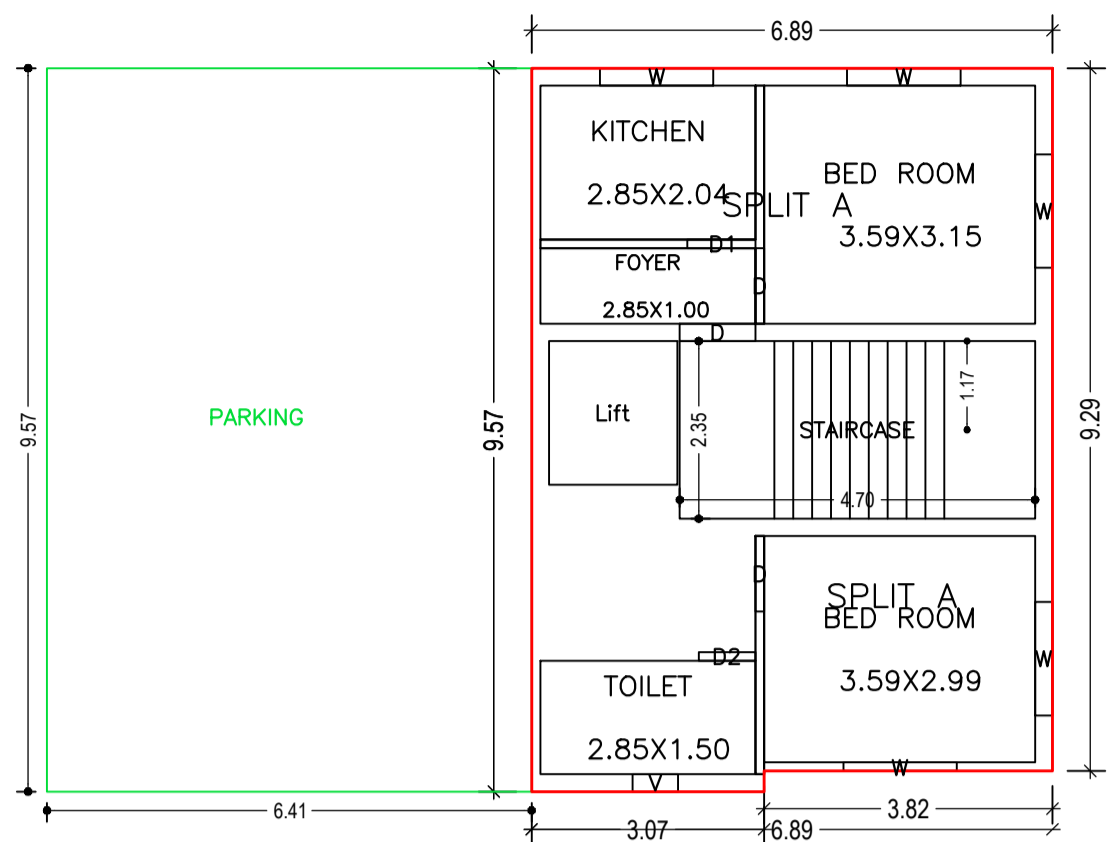

TERRACE FLOOR PLAN
(SCALE 1:100)

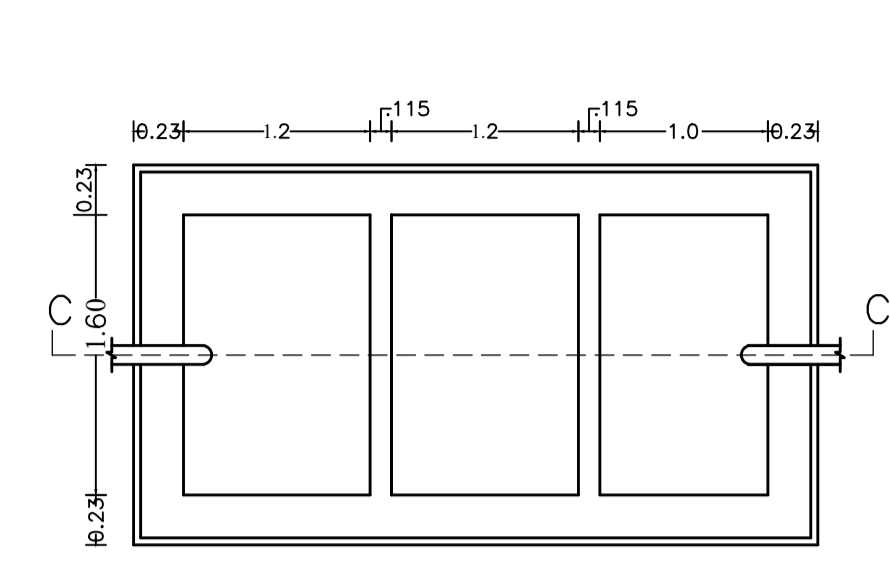

SEPTIC TANK PLAN
SCALE -1:50

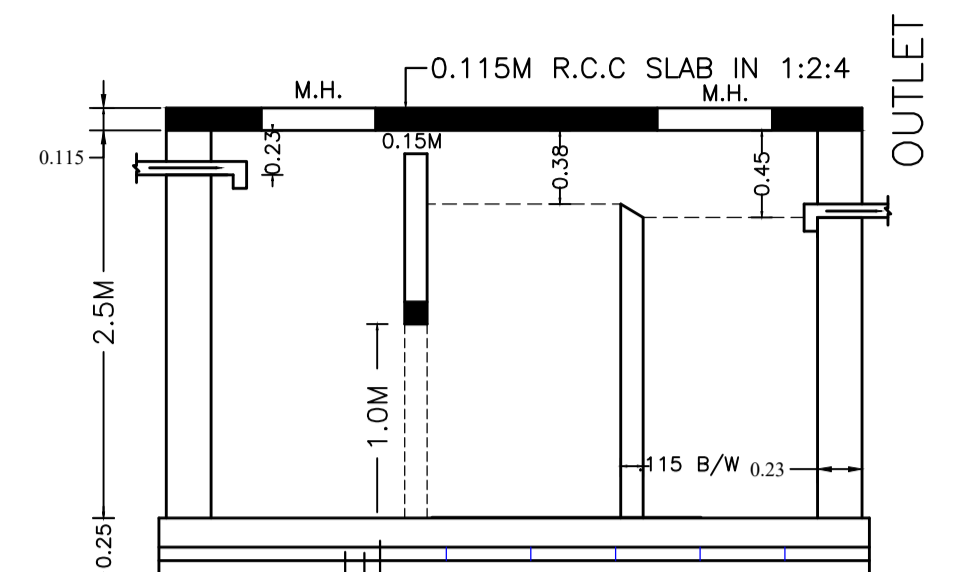

SECTION - SS
SCALE -1:50

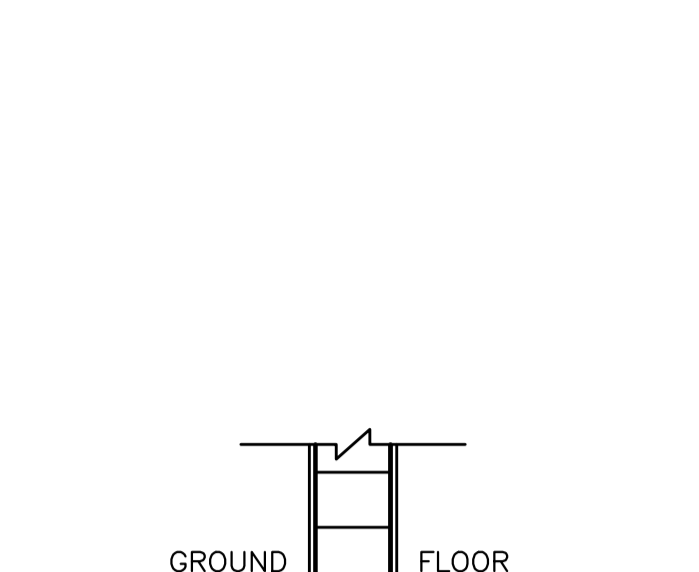

SECTION - CC
SCALE -1:25

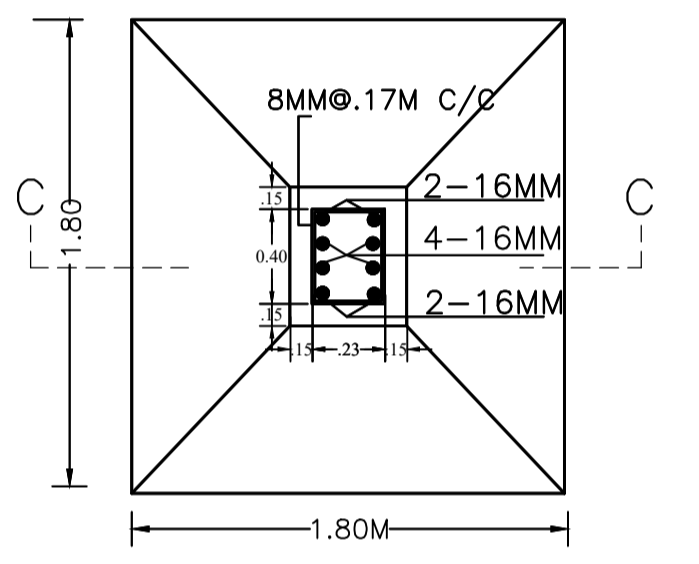

R.C.C. COL. FDN. PLAN
SCALE -1:25

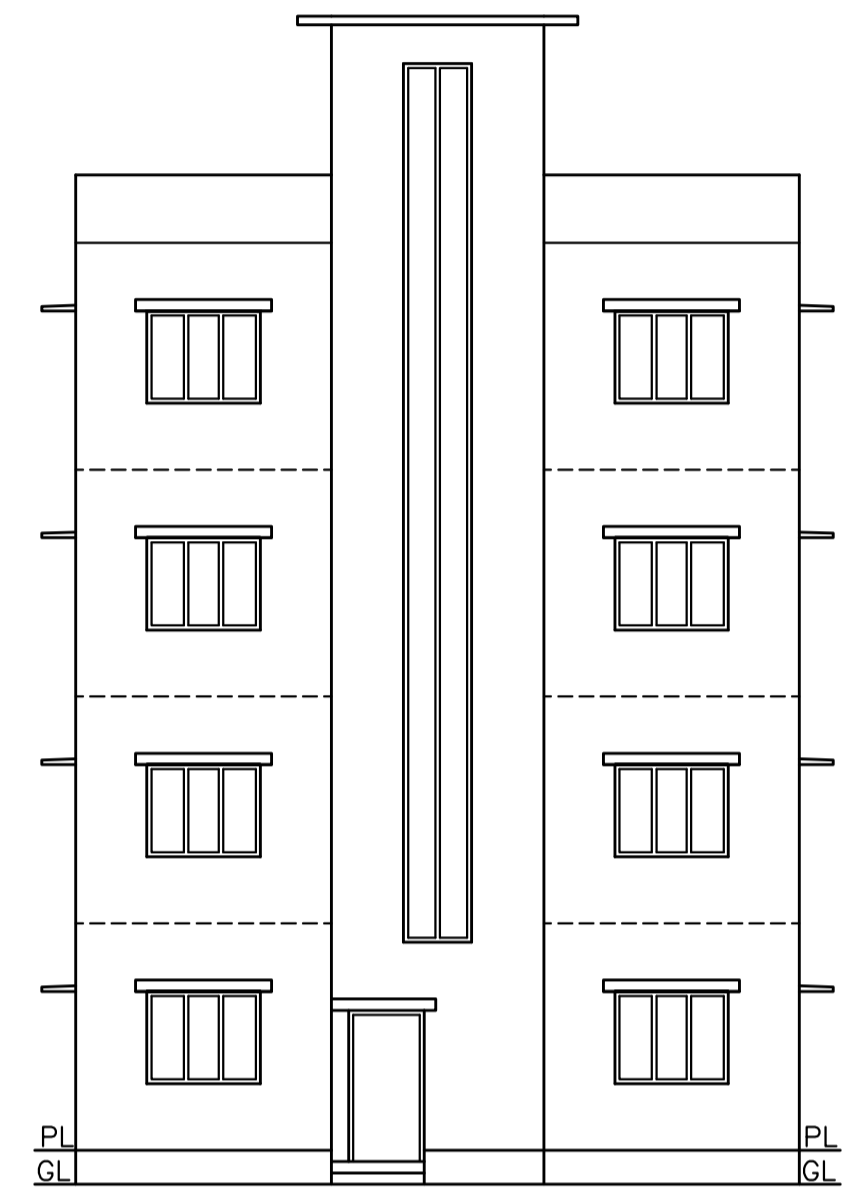

SOUTH SIDE ELEVATION
SCALE 1:100

GROUND FLOOR PLAN
(Proposed)
(SCALE 1:100)

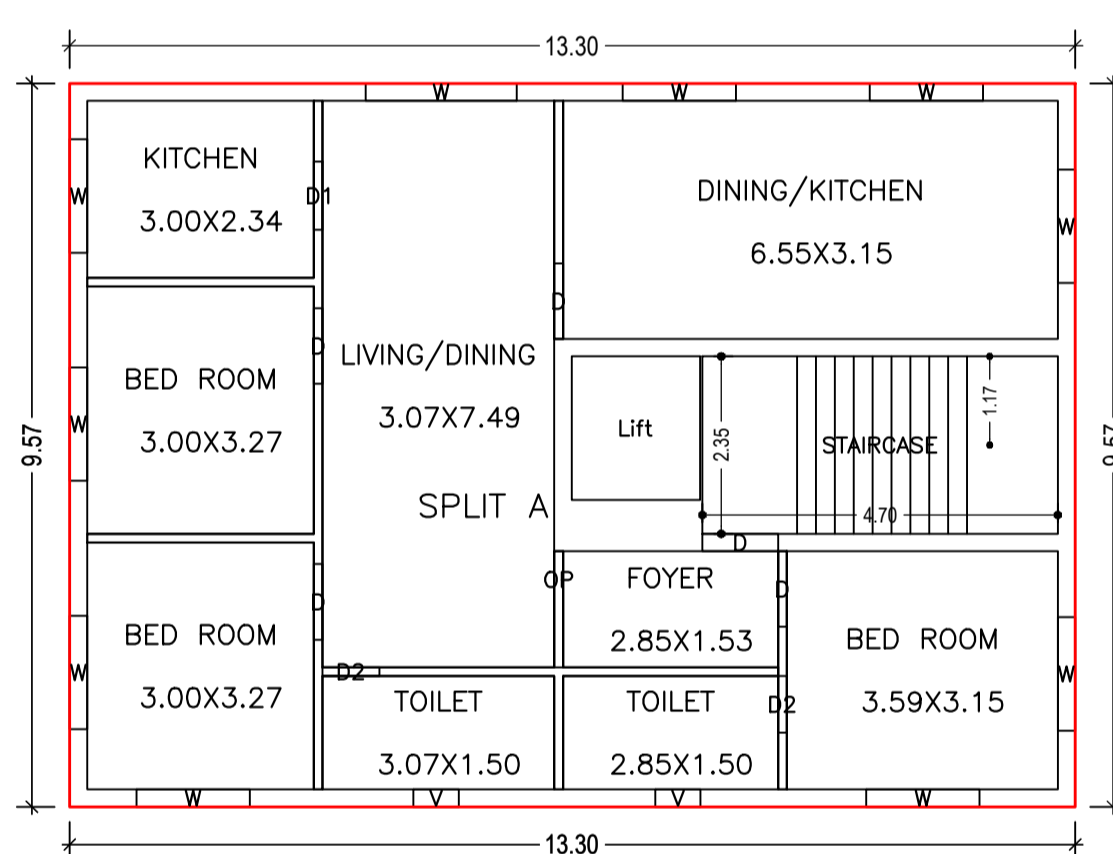

SECTION - AA
SCALE 1:100

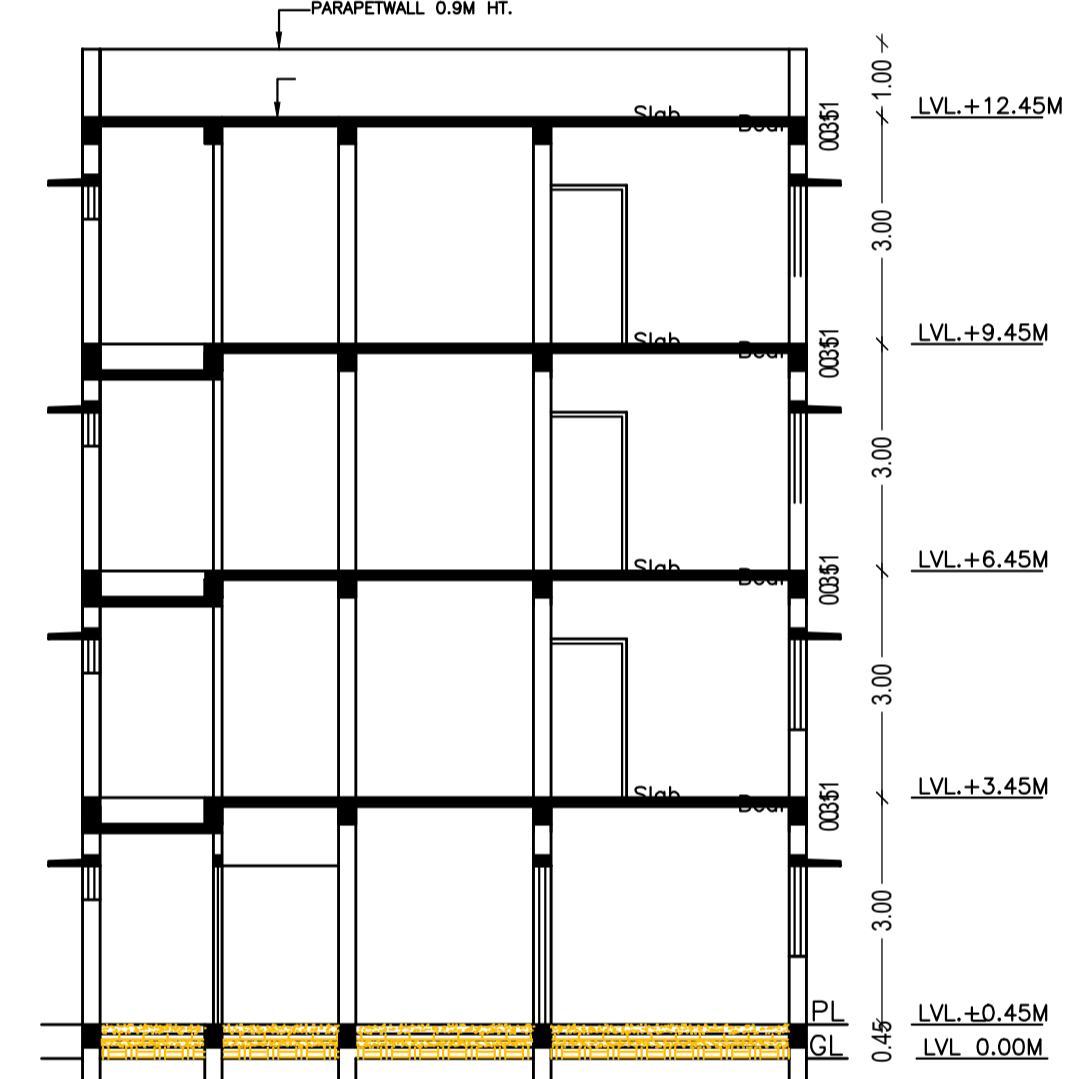

SECTION - BB
SCALE 1:100

TYPICAL - 1-3 FLOOR PLAN
(Proposed)
(SCALE 1:100)

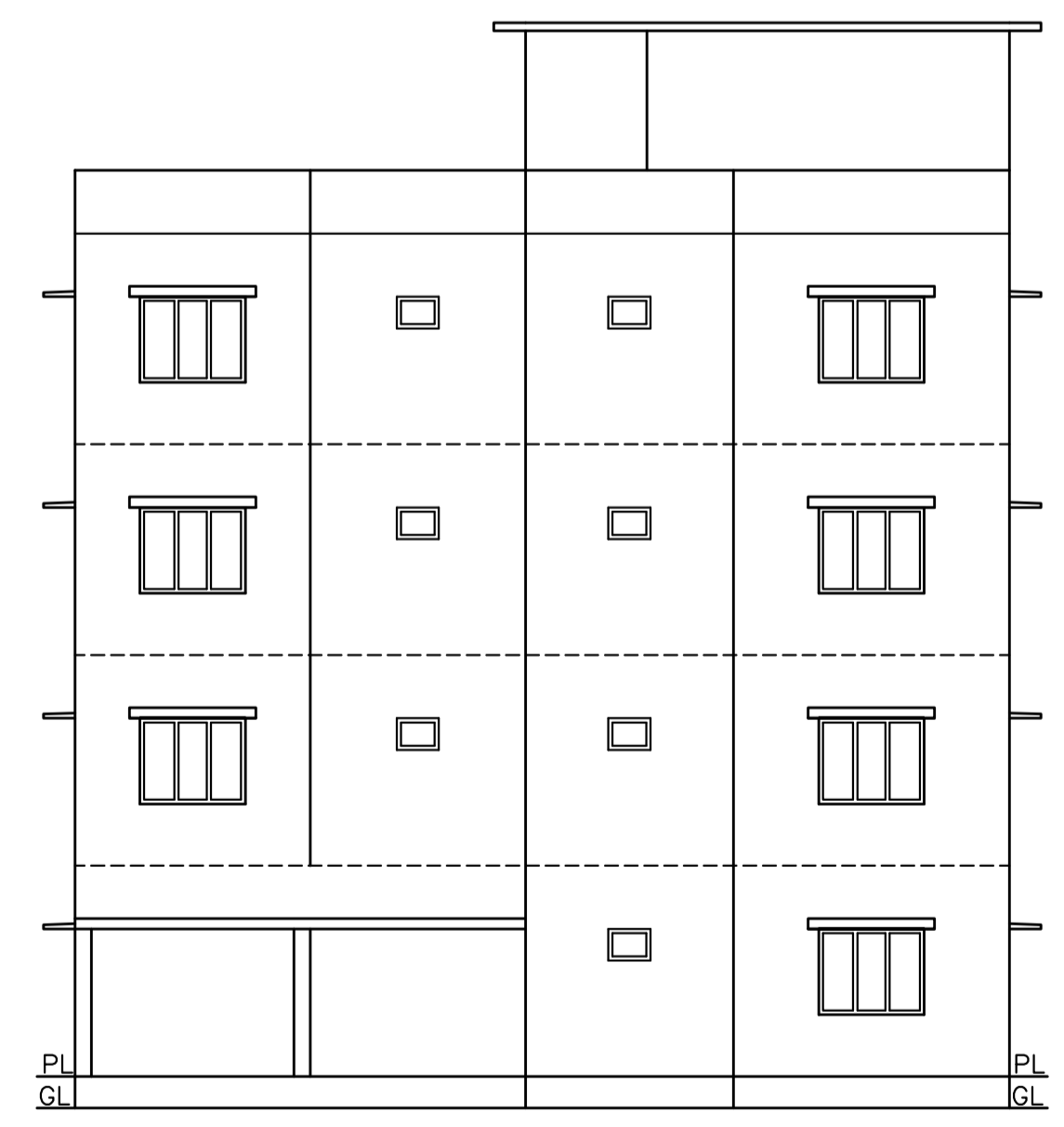

FRONT ELEVATION
SCALE 1:100

Floor Name	Total Built Up Area (Sq.mt.)	Deductions (Area in Sq.mt.)		Proposed FAR Area (Sq.mt.)		Total Consumed Additional FAR Area (Sq.mt.)	Trmt (No.)
		Lift	Parking	Resi.	Total FAR Area (Sq.mt.)		
Ground Floor	126.21	0.00	61.33	64.88	64.88	64.88	01
First Floor	127.25	3.23	0.00	124.02	124.02	124.02	00
Second Floor	127.25	3.23	0.00	124.02	124.02	124.02	00
Third Floor	127.25	3.23	0.00	124.02	124.02	124.02	00
Terrace Floor	0.00	0.00	0.00	0.00	0.00	0.00	00
Total :	507.96	9.69	61.33	436.94	436.94	436.94	01
Total Number of Same Buildings	1						
Total :	507.96	9.69	61.33	436.94	436.94	436.94	01

SCHEDULE OF DOOR:

BUILDING NAME	NAME	LENGTH	HEIGHT	NOS
A (RESIDENTIAL)	D2	0.75	2.10	07
A (RESIDENTIAL)	D1	0.90	2.10	04
A (RESIDENTIAL)	D	1.00	2.10	18
A (RESIDENTIAL)	OP	1.54	2.10	03

SCHEDULE OF WINDOW/VENTILATION:

BUILDING NAME	NAME	LENGTH	HEIGHT	NOS
A (RESIDENTIAL)	V	0.60	0.90	07
A (RESIDENTIAL)	W	1.50	1.20	32
A (RESIDENTIAL)	W	2.00	1.20	03

UnitBUA Table for Building :A (RESIDENTIAL)

FLOOR	Name	UnitBUA Type	UnitBUA Area	Carpet Area	No. of Rooms	No. of Tenement
GROUND FLOOR PLAN	SPLIT A	FLAT	330.70	319.14	3	1
TYPICAL - 1-3 FLOOR PLAN	SPLIT A	FLAT	0.00	0.00	2	0
Total:	-	-	330.70	319.14	32	1

LTP NAME AND SIGNATURE	STRUCTURAL ENG'S NAME AND SIGNATURE	BUILDER NAME AND SIGNATURE	DIGITAL SIGNATURE
EJAZ AHMAD MNAC/DFTMN/0008/2020			

Proposal Basic Information	
Proposal File No.	MNAC/BP/0036/W09/2022
Owner Name	DR. Shri MANOJ KUMAR
Khata No	311
Plot No	1405
Village Name	Dimna
Use	Residential
SubUse	Bungalow/ Dwelling / Non Apartment

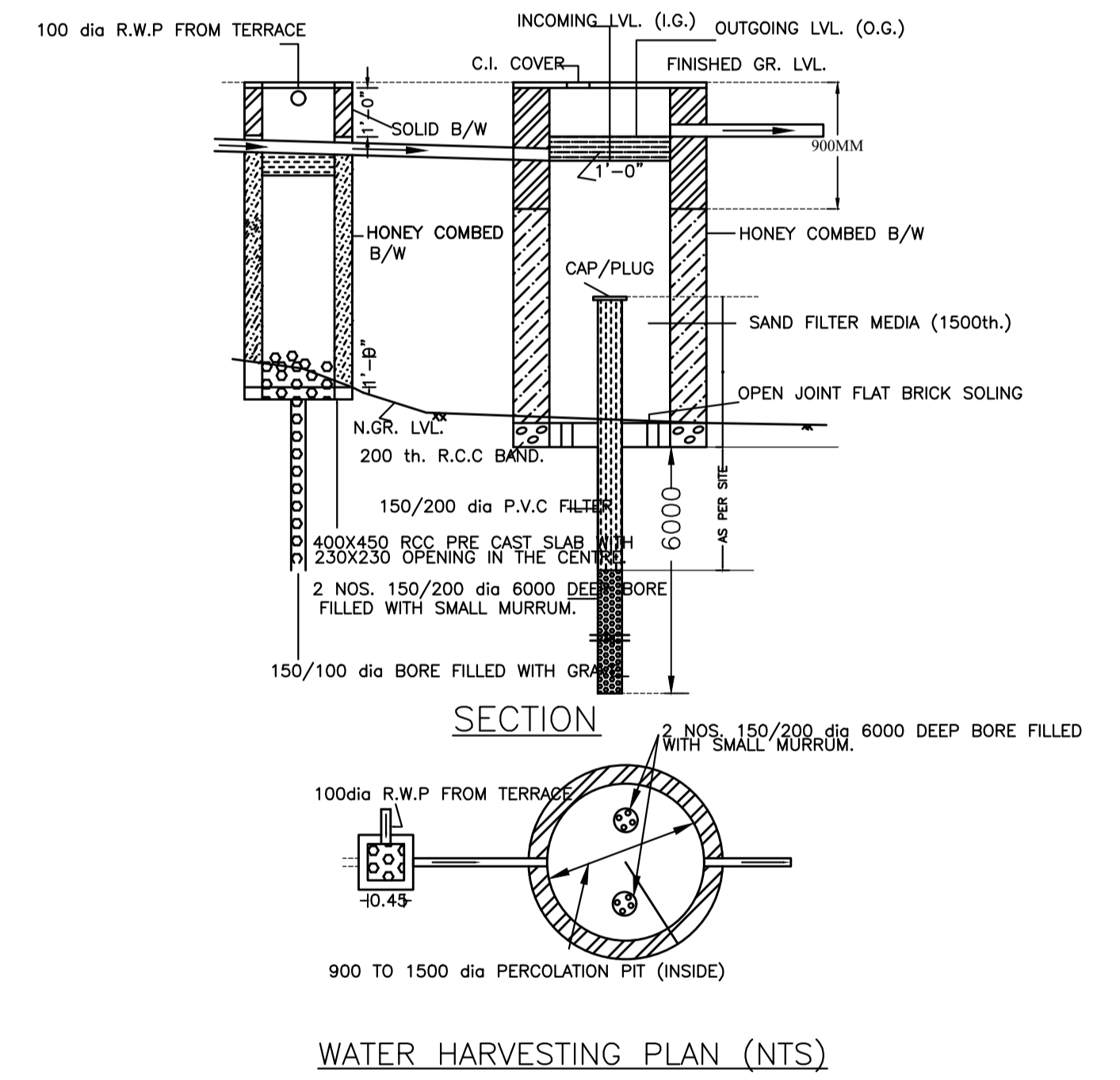
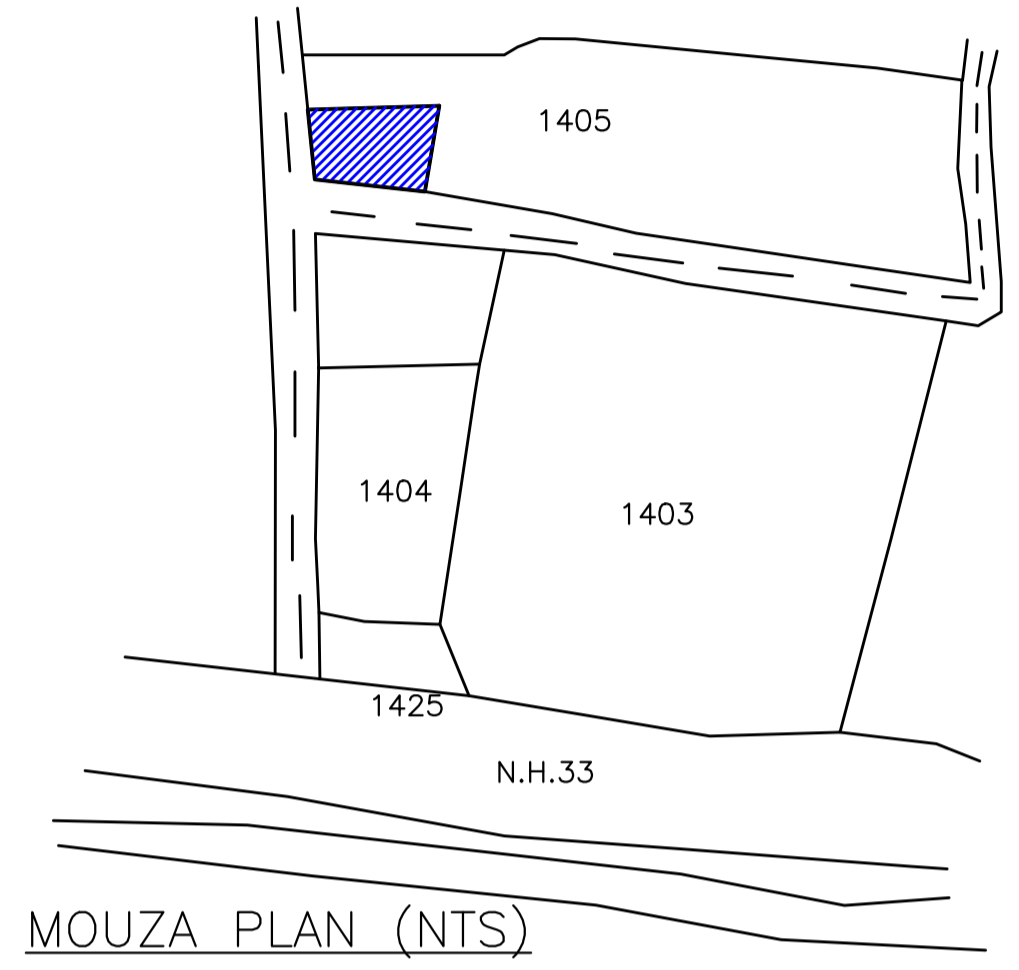

LTP NAME AND SIGNATURE	STRUCTURAL ENG'S NAME AND SIGNATURE	BUILDER NAME AND SIGNATURE	DIGITAL SIGNATURE
EJAZ AHMAD MNAC/DFTMN/0008/2020			