

FAR & Tenement Details (Table 4c-1)

Building	No. of Same Bldg	Total Built Up Area (Sq.mt.)	Deductions (Area in Sq.mt.)			Proposed FAR Area (Sq.mt.)	Total FAR Area (Sq.mt.)	Total Consumed Additional FAR Area (Sq.mt.)	Trmnt (No.)
			Lift	Balcony	Parking				
A (SHANTI DEVI)	1	366.97	6.46	3.99	51.24	305.28	305.28	305.28	01
Grand Total	1	366.97	6.46	3.99	51.24	305.28	305.28	305.28	01

Proposal Basic Information

Proposal File No.	MNAC/BP/0040/W09/2022
Owner Name	Smt. Shanti Devi
Khata No	382
Plot No	1738
Village Name	Mango
Use	Residential
SubUse	Bungalow/ Dwelling / Non Apartment

AREA STATEMENT MANGO MUNICIPAL CORPORATION	VERSION NO. : 1.0.66	SQ.MT.
PROJECT DETAIL:	VERSION DATE: 16/10/2020	
Region: JHARKHAND URBAN LOCAL BODIES	Plot Use: Residential	
District: EAST SINGHBHUM	Plot SubUse: Bungalow/ Dwelling / Non Apartment	
Authority: MANGO MUNICIPAL CORPORATION	PlotNearbyReligiousStructure: NA	
Inward No: MNAC/BP/0040/W09/2022	PlotSubPlot No: 1738	
Application Type: General Proposal	North: Survey No. - other plot	
Project Type: Building Permission	South: Survey No. - other plot	
Nature of Development: New	East: Survey No. - other plot	
Location of Development Area: Old Area	West: Road Width - 5.95	
AREA DETAILS:		
AREA OF PLOT (Minimum)	(A)	195.16
NET AREA OF PLOT(Gross Plot Area - Deduction from Gross Plot area)	(A-Deductions)	195.16
Deduction for Balance Plot Area(from Gross Plot Area)		
Common Plot		17.50
Total		17.50
BALANCE AREA OF PLOT(Net Plot Area - Recreational/Amenity space)	(A-Deductions)	177.66
PLOT AREA FOR COVERAGE(Net Plot Area)	(A-Deductions)	195.16
Plot Area for FAR (Net Plot Area + RoadWidening Area)	(A-Deductions)	195.16
COVERAGE CHECK		
Permissible Coverage area (70.00 %)		136.61
Proposed Coverage Area (61.31 %)		119.66
Total Prop. Coverage Area (61.31 %)		119.66
Balance coverage area (8.69 %)		16.95
FAR CHECK		
Perm. FAR Area (1.800)		351.29
Total Perm. FAR area		351.29
Residential FAR		305.28
Proposed FAR Area		305.28
Total Proposed FAR Area		305.28
Consumed FAR (Factor)		1.56
Balance FAR Area		46.01
BUILT UP AREA CHECK		
Total Proposed BuiltUp Area		366.97
ARCHITECT (Regd)	L K Suman	
ENGINEER (Regd)		
SUPERVISOR (Regd)		
OWNER (Regd)	Smt. Shanti Devi	
DEVELOPMENT AUTHORITY	LOCAL BODY	

COLOR INDEX	
PLOT BOUNDARY	Black
ABUTTING ROAD	Green
PROPOSED CONSTRUCTION	Red
COMMON PLOT	Yellow
ROAD WIDENING AREA	Orange
EXISTING (To be retained)	Blue
EXISTING (To be demolished)	Light Blue

Buildingwise Floor FAR Details

Floor Name	Building Name A (SHANTI DEVI)		Total	
	Proposed Built Up Area (Sq.mt.)	Proposed FAR Area (Sq.mt.)	Total Proposed Built Up Area (Sq.mt.)	Total FAR Area (Sq.mt.)
Ground Floor	119.67	68.43	119.67	68.43
First Floor	119.66	116.43	119.66	116.43
Second Floor	127.64	120.42	127.64	120.42
Terrace Floor	0.00	0.00	0.00	0.00
Total	366.97	305.28	366.97	305.28

Building USE/SUBUSE Details

Building Name	Building Use	Building SubUse	Building Structure
A (SHANTI DEVI)	Residential	Bungalow/ Dwelling / Non Apartment	Non-Highrise

LTP NAME AND SIGNATURE	STRUCTURAL ENG'S NAME AND SIGNATURE	BUILDER NAME AND SIGNATURE	DIGITAL SIGNATURE
L K Suman MNAC/ENG/0008/2016			

Proposal Basic Information	
Proposal File No.	MNAC/BP/0040/W09/2022
Owner Name	Smt. Shanti Devi
Khata No	382
Plot No	1738
Village Name	Mango
Use	Residential
SubUse	Bungalow/ Dwelling / Non Apartment

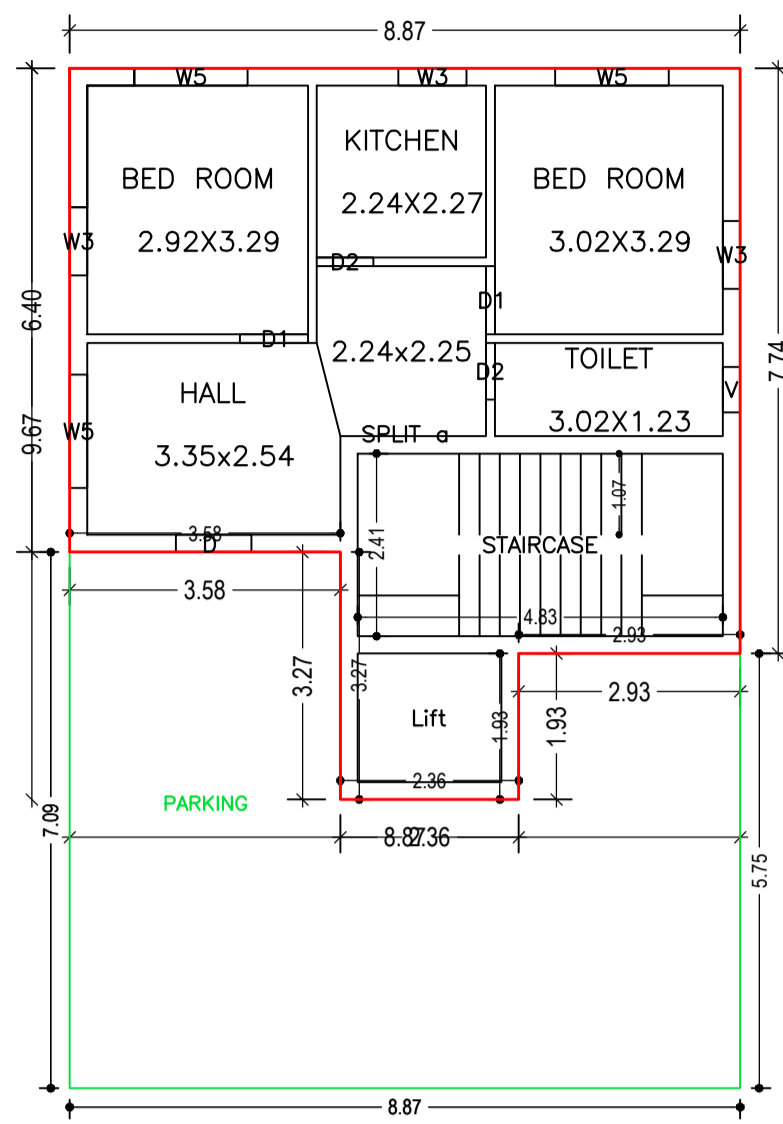

GROUND FLOOR PLAN (Proposed) (SCALE 1:100)

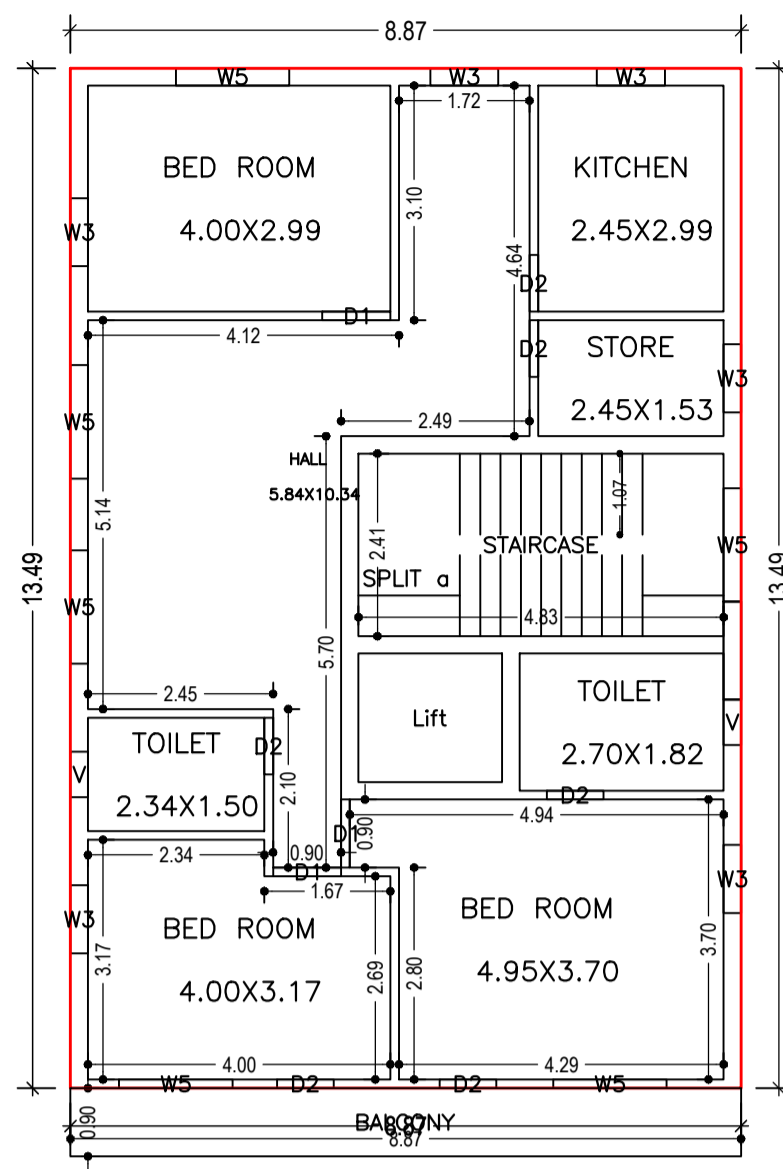

SECOND FLOOR PLAN (Proposed) (SCALE 1:100)

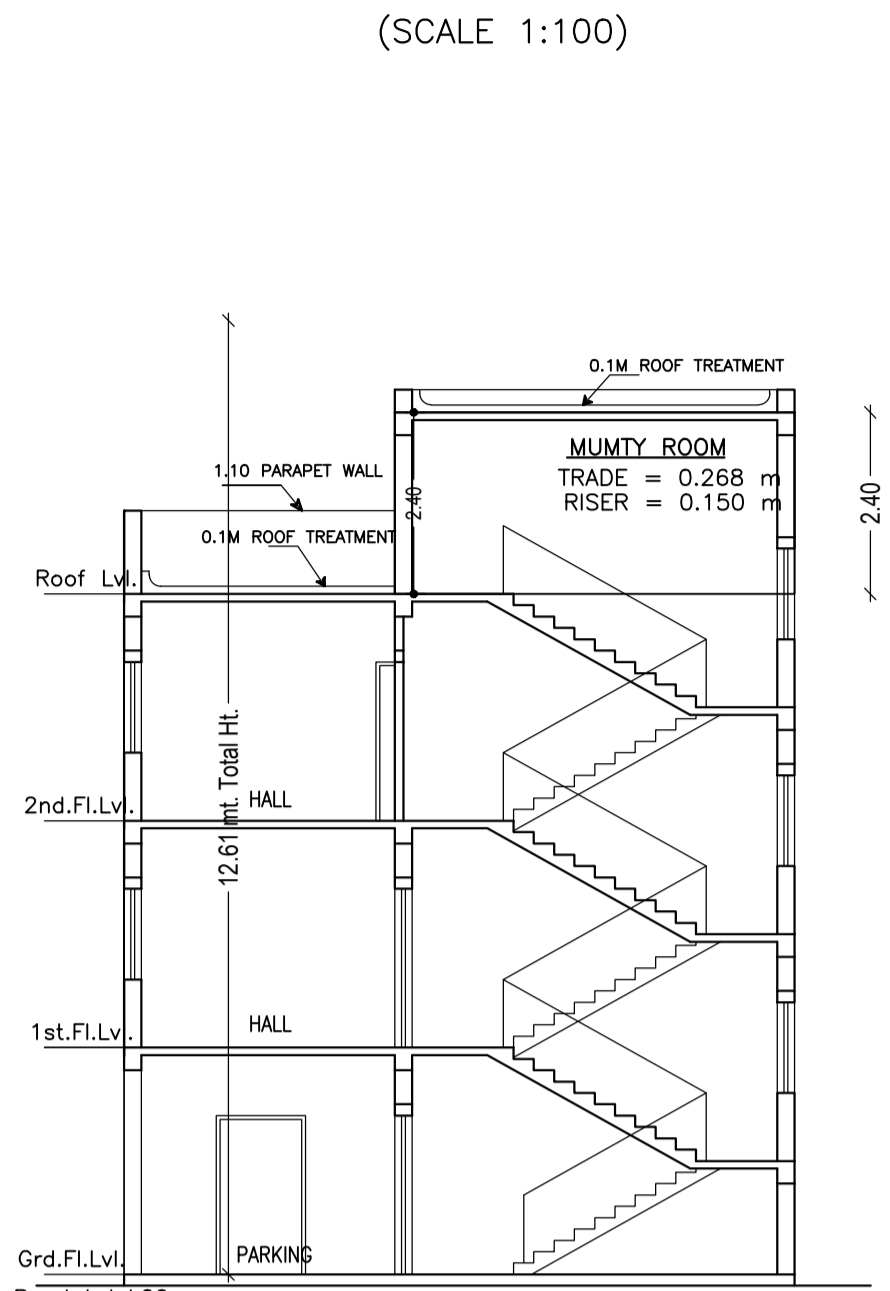

SECTION X-X (SCALE 1:100)

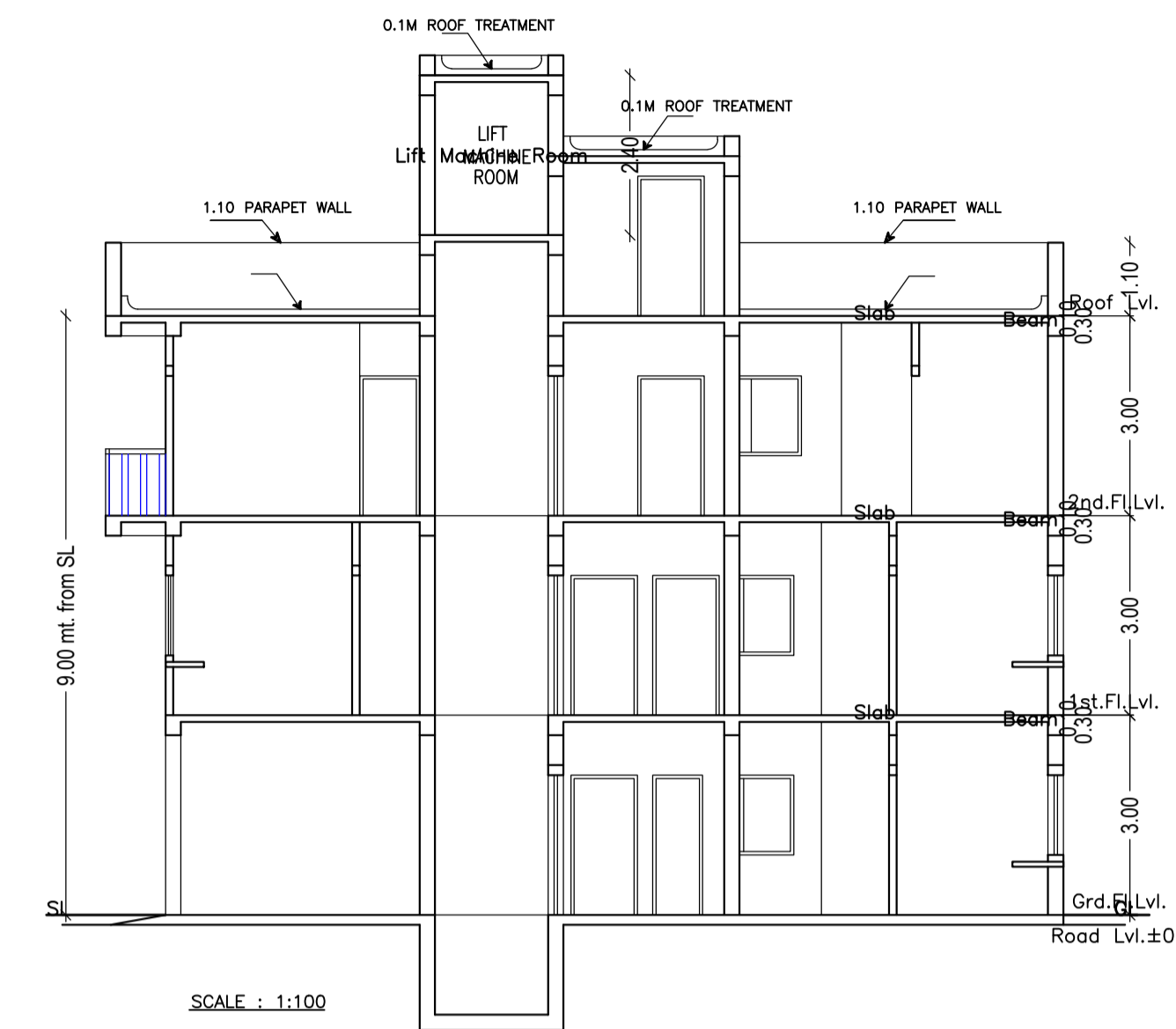

SCALE : 1:100

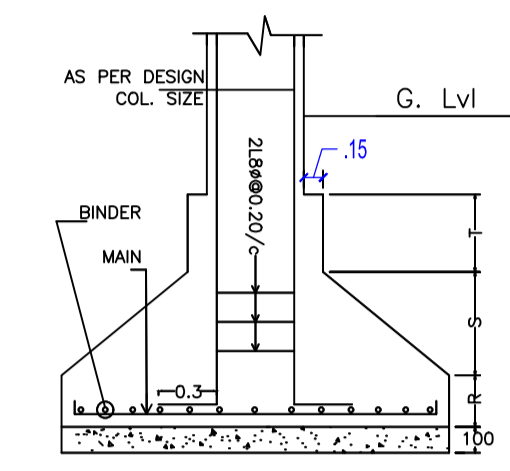

DETAIL OF COLUMN & FOOTING

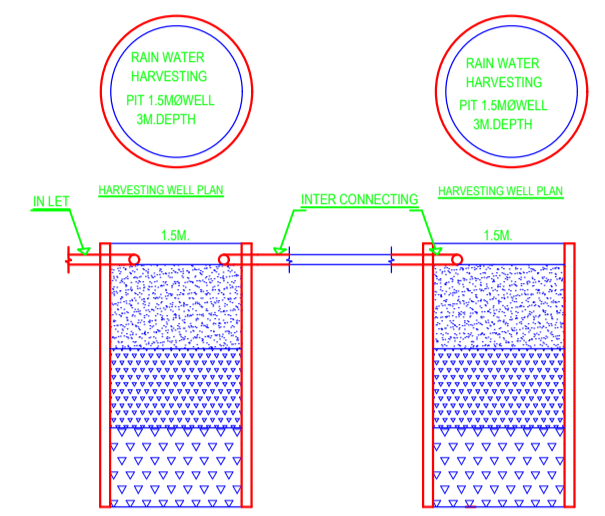

HARVESTING WELL SECTION

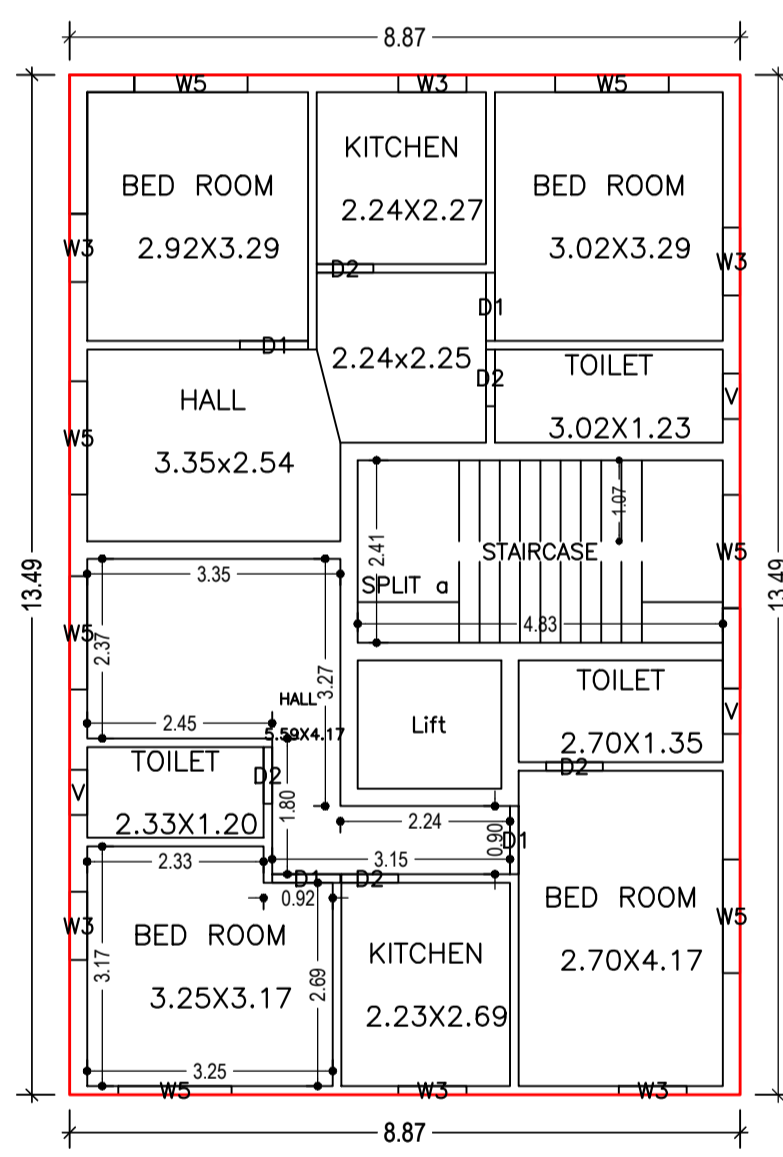

FIRST FLOOR PLAN (Proposed) (SCALE 1:100)

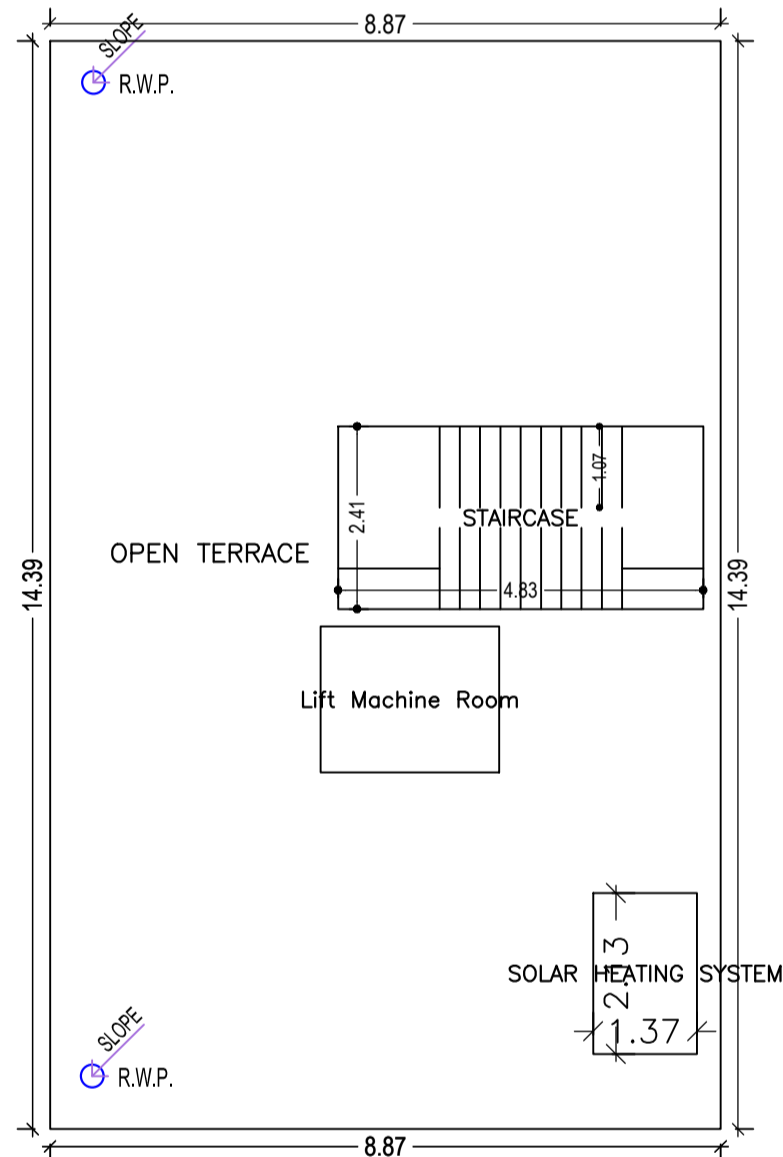

TERRACE FLOOR PLAN (SCALE 1:100)

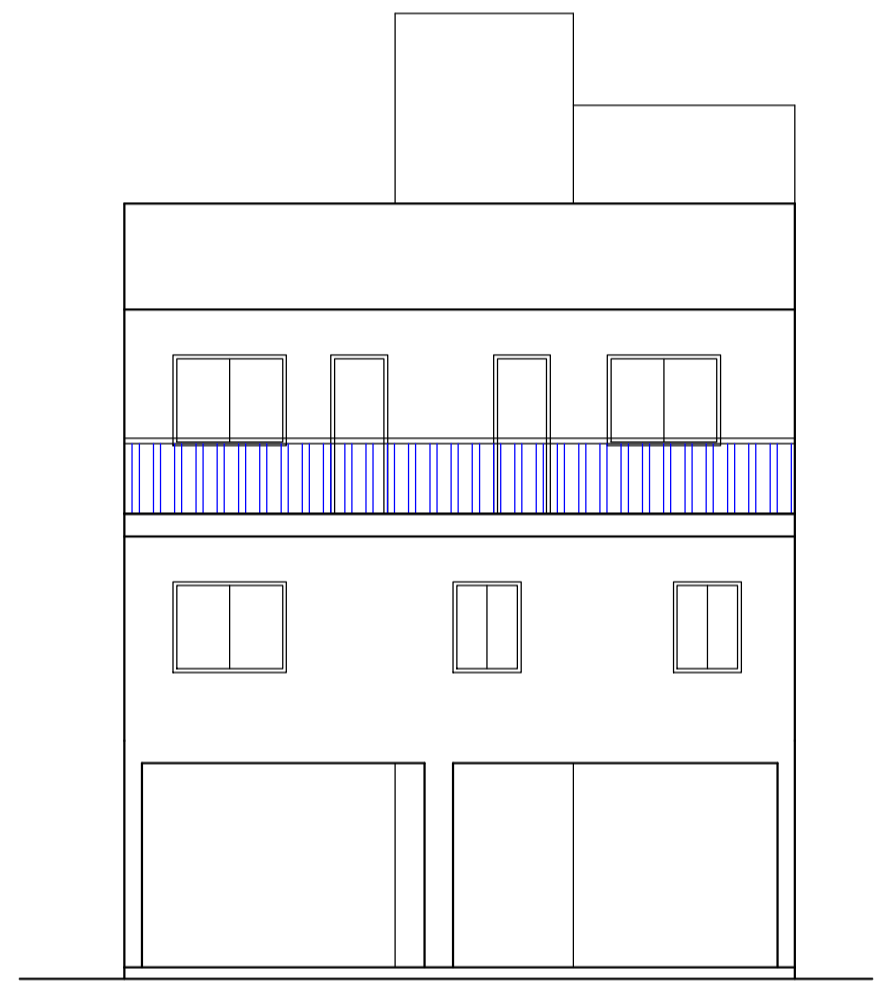

FRONT ELEVATION (SCALE : 1:100)

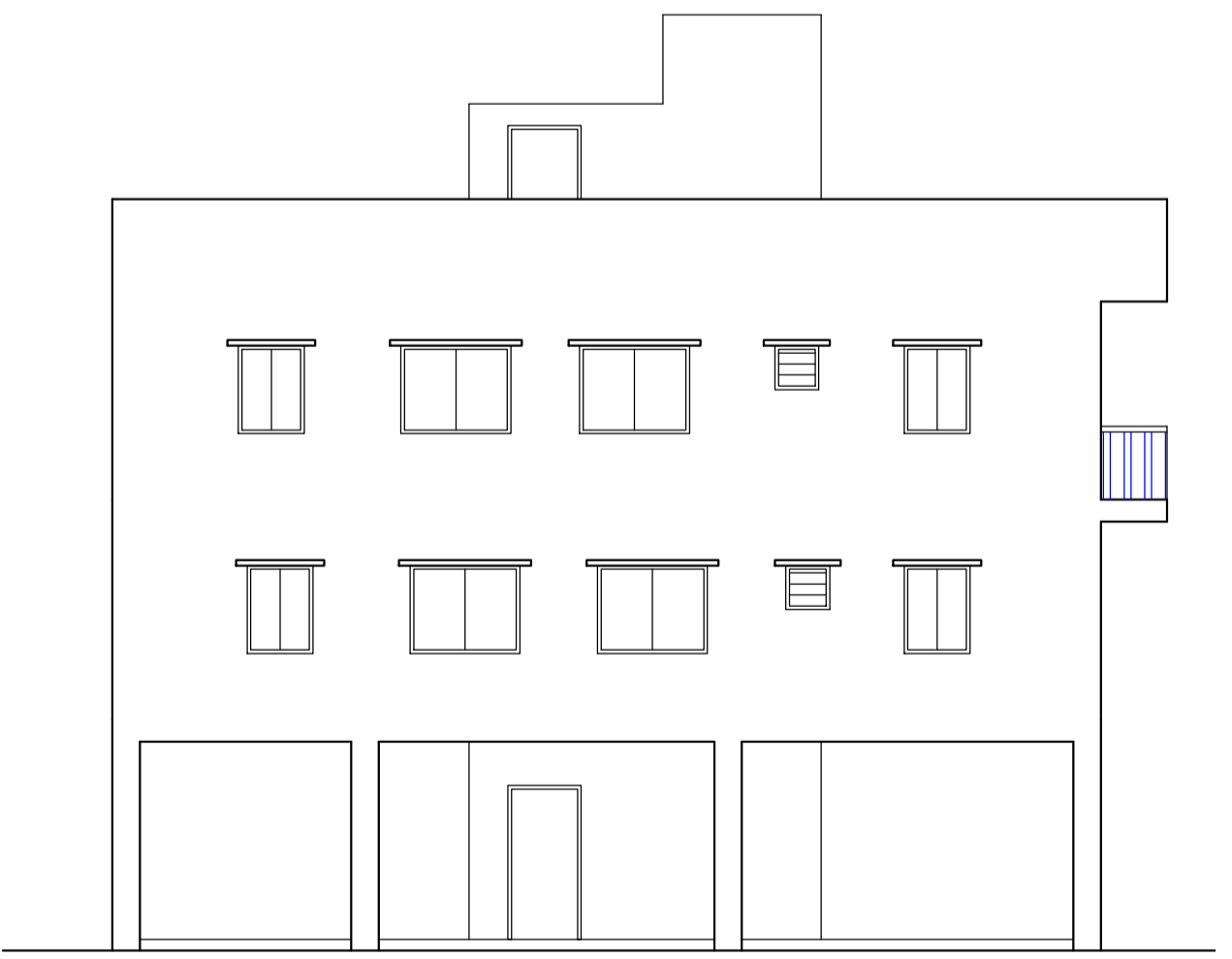

SIDE - A ELEVATION (SCALE : 1:100)

Building :A (SHANTI DEVI)

Floor Name	Total Built Up Area (Sq.mt.)	Deductions (Area in Sq.mt.)			Proposed FAR Area (Sq.mt.)	Total FAR Area (Sq.mt.)	Total Consumed Additional FAR Area (Sq.mt.)	Tnmt (No.)
		Lift	Balcony	Parking				
Ground Floor	119.67	0.00	0.00	51.24	68.43	68.43	01	
First Floor	119.66	3.23	0.00	0.00	116.43	116.43	00	
Second Floor	127.64	3.23	3.99	0.00	120.42	120.42	00	
Terrace Floor	0.00	0.00	0.00	0.00	0.00	0.00	00	
Total :	366.97	6.46	3.99	51.24	305.28	305.28	01	
Total Number of Same Buildings	1							
Total :	366.97	6.46	3.99	51.24	305.28	305.28	01	

SCHEDULE OF DOOR:

BUILDING NAME	NAME	LENGTH	HEIGHT	NOS
A (SHANTI DEVI)	D2	0.75	2.10	13
A (SHANTI DEVI)	D1	0.90	2.10	09
A (SHANTI DEVI)	D	1.00	2.10	01

SCHEDULE OF WINDOW/VENTILATION:

BUILDING NAME	NAME	LENGTH	HEIGHT	NOS
A (SHANTI DEVI)	V	0.60	0.60	06
A (SHANTI DEVI)	W3	0.90	1.20	15
A (SHANTI DEVI)	W5	1.50	1.20	16

UnitBUA Table for Building :A (SHANTI DEVI)

FLOOR	Name	UnitBUA Type	UnitBUA Area	Carpet Area	No. of Rooms	No. of Tenement
GROUND FLOOR PLAN	SPLIT a	FLAT	306.05	296.39	5	1
FIRST FLOOR PLAN	SPLIT a	FLAT	0.00	0.00	11	0
SECOND FLOOR PLAN	SPLIT a	FLAT	0.00	0.00	8	0
Total:	-	-	306.05	296.39	24	1

Balcony Calculations Table

FLOOR	SIZE	AREA	TOTAL AREA
SECOND FLOOR PLAN	0.90 X 8.87 X 1 X 1	7.98	7.98
Total	-	-	7.98

LTP NAME AND SIGNATURE	STRUCTURAL ENG'S NAME AND SIGNATURE	BUILDER NAME AND SIGNATURE	DIGITAL SIGNATURE
L K Suman MNAC/ENG/0008/2016			