

SITE - PLAN
SCALE 1:100

SECTION

FAR & Tenement Details (Table 4c-1)

Building	No. of Same Bldg	Total Built Up Area (Sq.mt.)	Deductions (Area in Sq.mt.)		Proposed FAR Area (Sq.mt.)	Total FAR Area (Sq.mt.)	Total Consumed Additional FAR Area (Sq.mt.)	Trmt (No.)
			Lift	Parking				
A (RESIDENTIAL)	1	355.08	6.44	72.42	276.22	276.22	276.22	01
Grand Total :	1	355.08	6.44	72.42	276.22	276.22	276.22	01

Proposal Basic Information

Proposal File No.	MNAC/BI/0070/W09/2022
Owner Name	TRIBENI PRASAD
Khata No	584
Plot No	1030, 1031
Village Name	Pardih
Use	Residential
SubUse	Bungalow/ Dwelling / Non Apartment

AREA STATEMENT MANGO MUNICIPAL CORPORATION	VERSION NO. : 1.0.64
PROJECT DETAIL:	VERSION DATE: 16/10/2020
Region: JHARKHAND URBAN LOCAL BODIES	Plot Use: Residential
District: EAST SINGHBHUM	Plot SubUse: Bungalow/ Dwelling / Non Apartment
Authority: MANGO MUNICIPAL CORPORATION	PlotNearbyReligiousStructure: NA
Inward No: MNAC/BI/0070/W09/2022	PlotSubPlot No: 1030, 1031
Application Type: General Proposal	North: -
Project Type: Building Permission	South: -
Nature of Development: New	East: -
Location of Development Area: Old Area	West: -
AREA DETAILS:	SQ.MT.
AREA OF PLOT (Minimum)	(A) 200.66
NET AREA OF PLOT(Gross Plot Area - Deduction from Gross Plot area)	(A-Deductions) 200.66
Deduction for Balance Plot Area(from Gross Plot Area)	
Common Plot	17.60
Total	17.60
BALANCE AREA OF PLOT(Net Plot Area - Recreational/Amenity space)	(A-Deductions) 183.06
PLOT AREA FOR COVERAGE(Net Plot Area)	(A-Deductions) 200.66
Plot Area for FAR (Net Plot Area + Road Widening Area)	(A-Deductions) 200.66
COVERAGE CHECK	
Permissible Coverage area (70.00 %)	140.46
Proposed Coverage Area (58.99 %)	118.36
Total Prop. Coverage Area (58.99 %)	118.36
Balance coverage area (11.01 %)	22.10
FAR CHECK	
Perm. FAR Area (1.800)	361.19
Total Perm. FAR area	361.19
Residential FAR	276.22
Proposed FAR Area	276.22
Total Proposed FAR Area	276.22
Consumed FAR (Factor)	1.38
Balance FAR Area	84.97
BUILT UP AREA CHECK	
Total Proposed BuiltUp Area	355.08
ARCHITECT (Regd)	EJAZ AHMAD
ENGINEER (Regd)	
SUPERVISOR (Regd)	
OWNER (Regd)	TRIBENI PRASAD
DEVELOPMENT AUTHORITY	LOCAL BODY

COLOR INDEX	
PLOT BOUNDARY	Black
ABUTTING ROAD	Green
PROPOSED CONSTRUCTION	Red
COMMON PLOT	Yellow
ROAD WIDENING AREA	Orange
EXISTING (To be retained)	Blue
EXISTING (To be demolished)	Light Blue

Buildingwise Floor FAR Details

Floor Name	Building Name A (RESIDENTIAL)		Total	
	Proposed Built Up Area (Sq.mt.)	Proposed FAR Area (Sq.mt.)	Total Proposed Built Up Area (Sq.mt.)	Total FAR Area (Sq.mt.)
Ground Floor	118.36	45.94	118.36	45.94
First Floor	118.36	115.14	118.36	115.14
Second Floor	118.36	115.14	118.36	115.14
Terrace Floor	0.00	0.00	0.00	0.00
Total :	355.08	276.22	355.08	276.22

Building USE/SUBUSE Details

Building Name	Building Use	Building SubUse	Building Structure
A (RESIDENTIAL)	Residential	Bungalow/ Dwelling / Non Apartment	Non-Highrise

LTP NAME AND SIGNATURE	STRUCTURAL ENG'S NAME AND SIGNATURE	BUILDER NAME AND SIGNATURE	DIGITAL SIGNATURE
EJAZ AHMAD MNAC/DFTMN/0008/2020			

Proposal Basic Information	
Proposal File No.	MNAC/BI/0070/W09/2022
Owner Name	TRIBENI PRASAD
Khata No	584
Plot No	1030, 1031
Village Name	Pardih
Use	Residential
SubUse	Bungalow/ Dwelling / Non Apartment

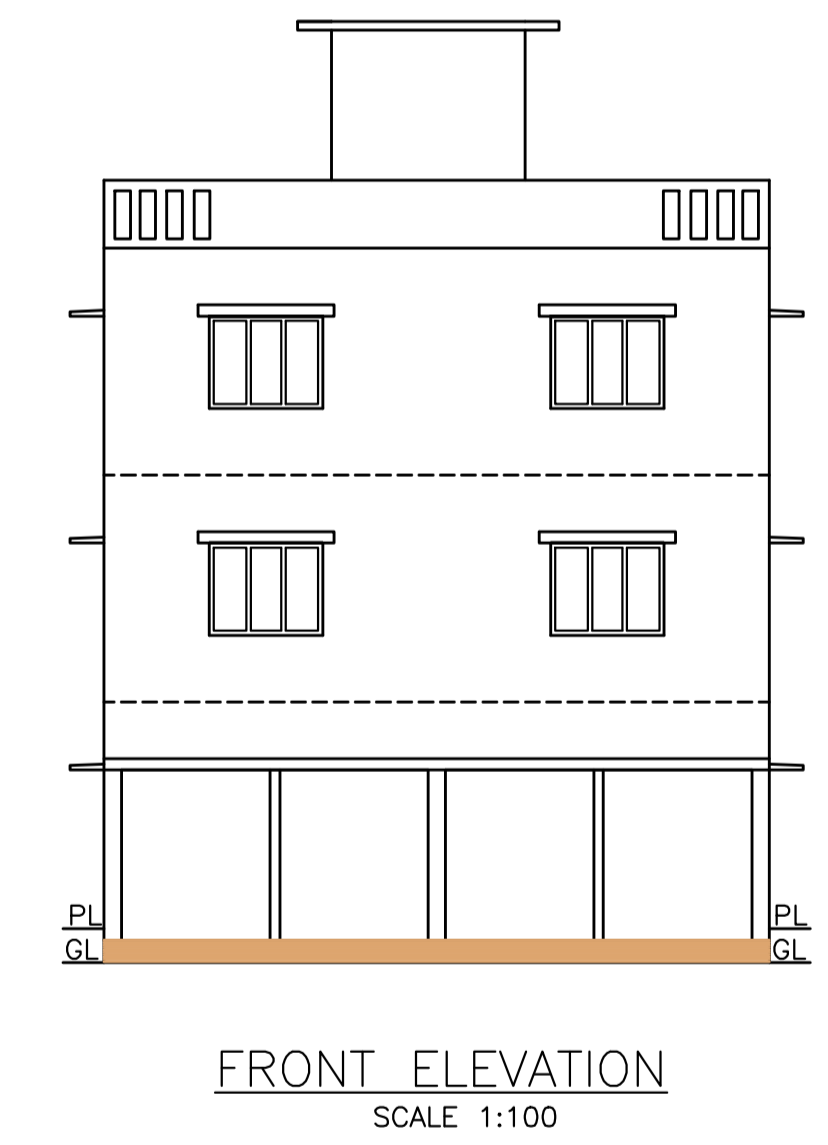
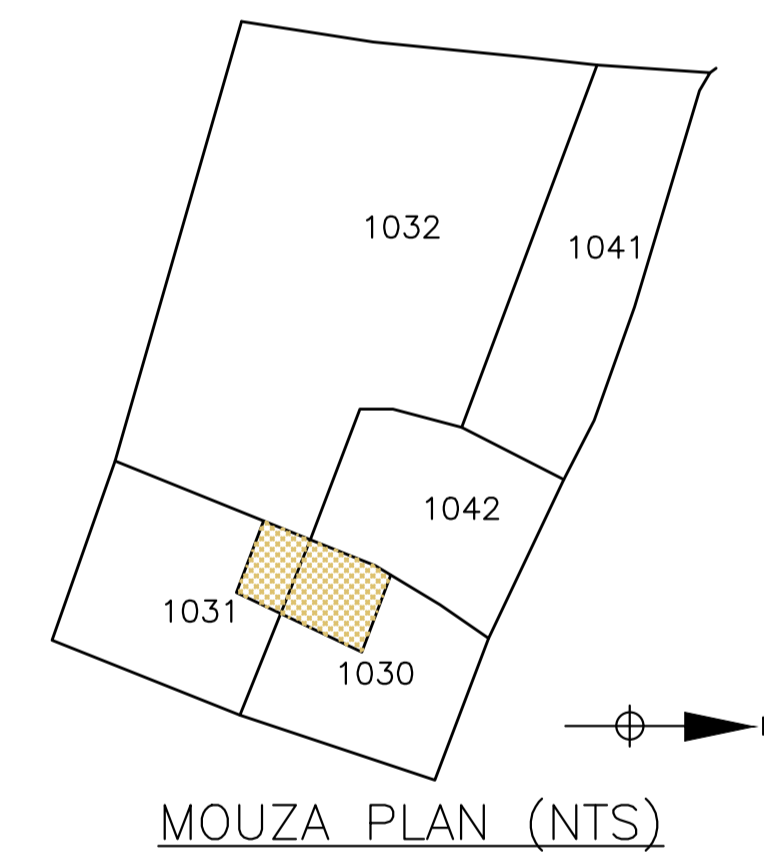
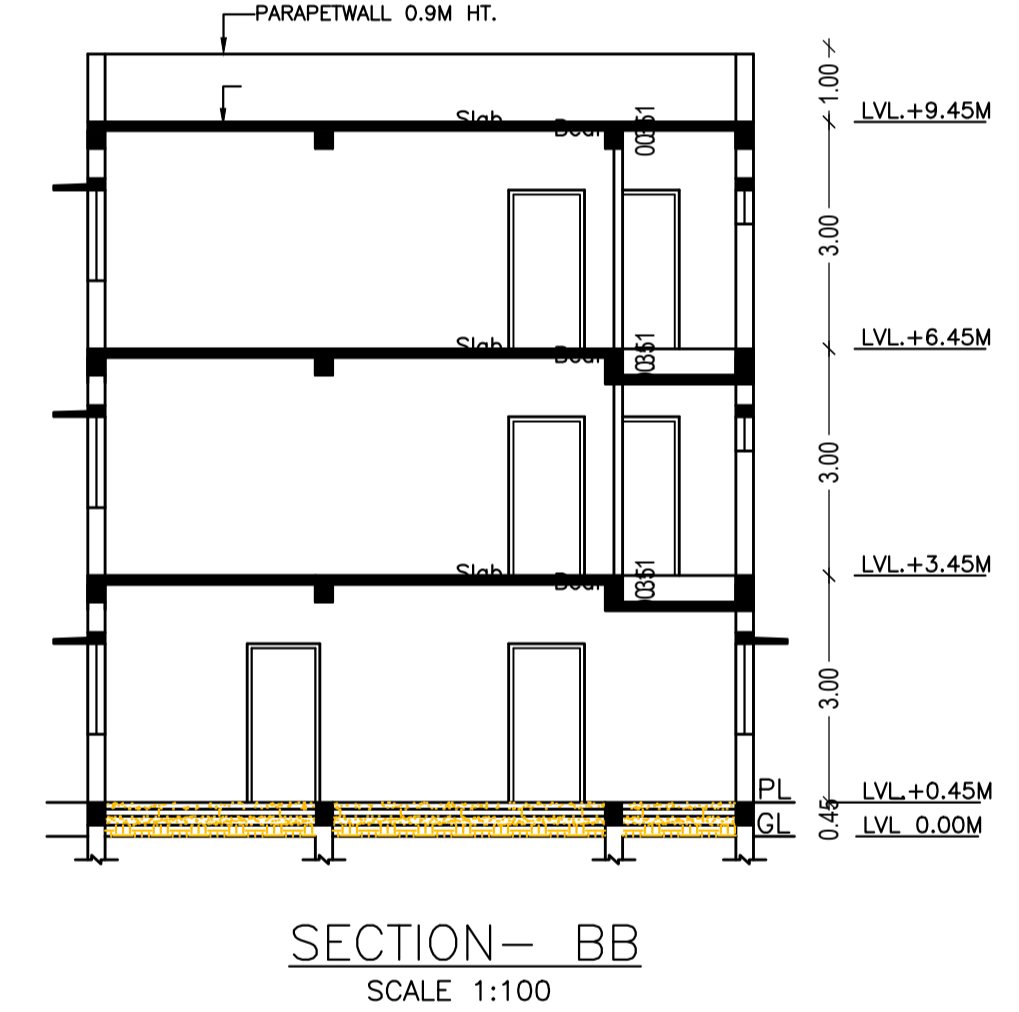
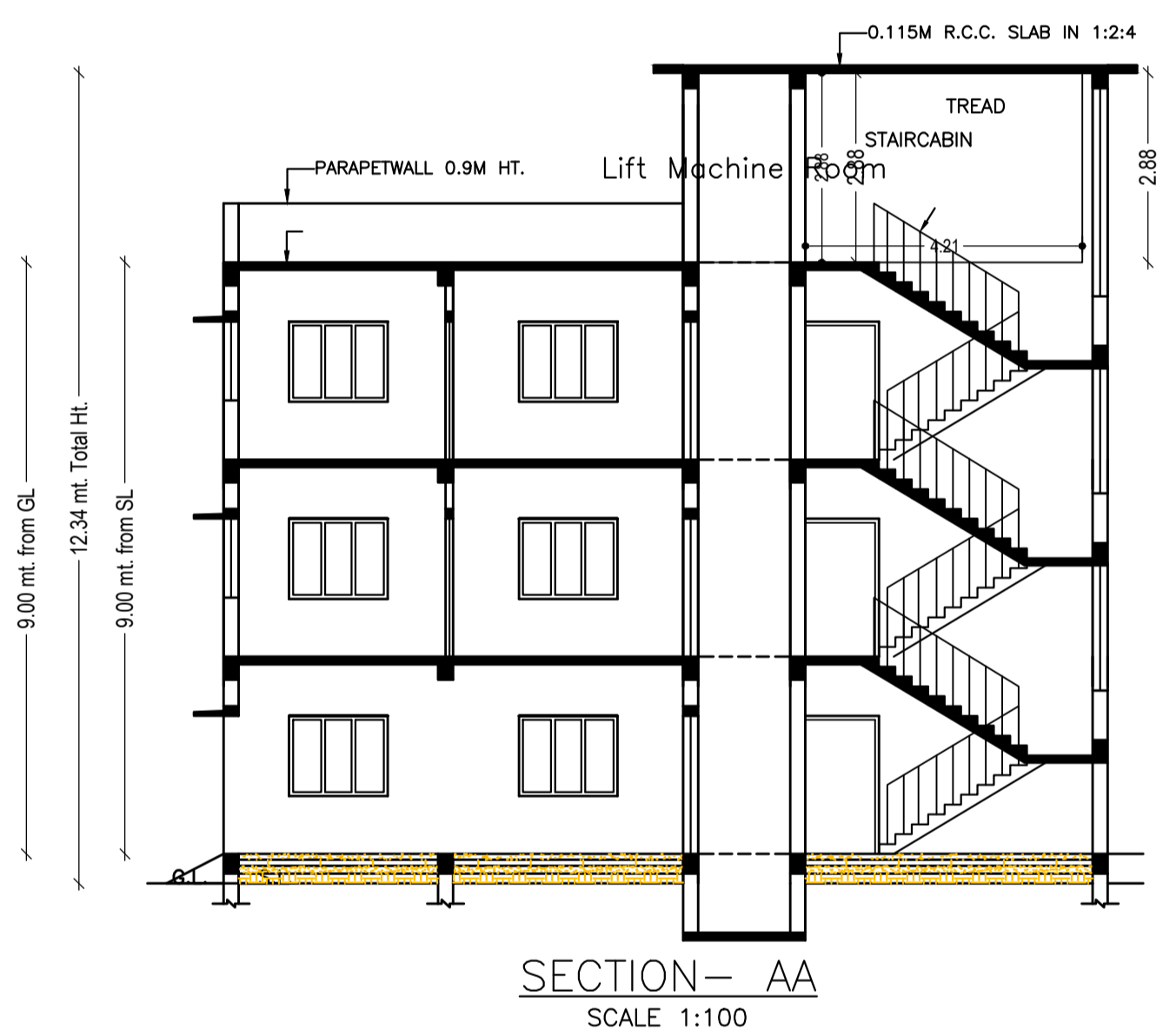
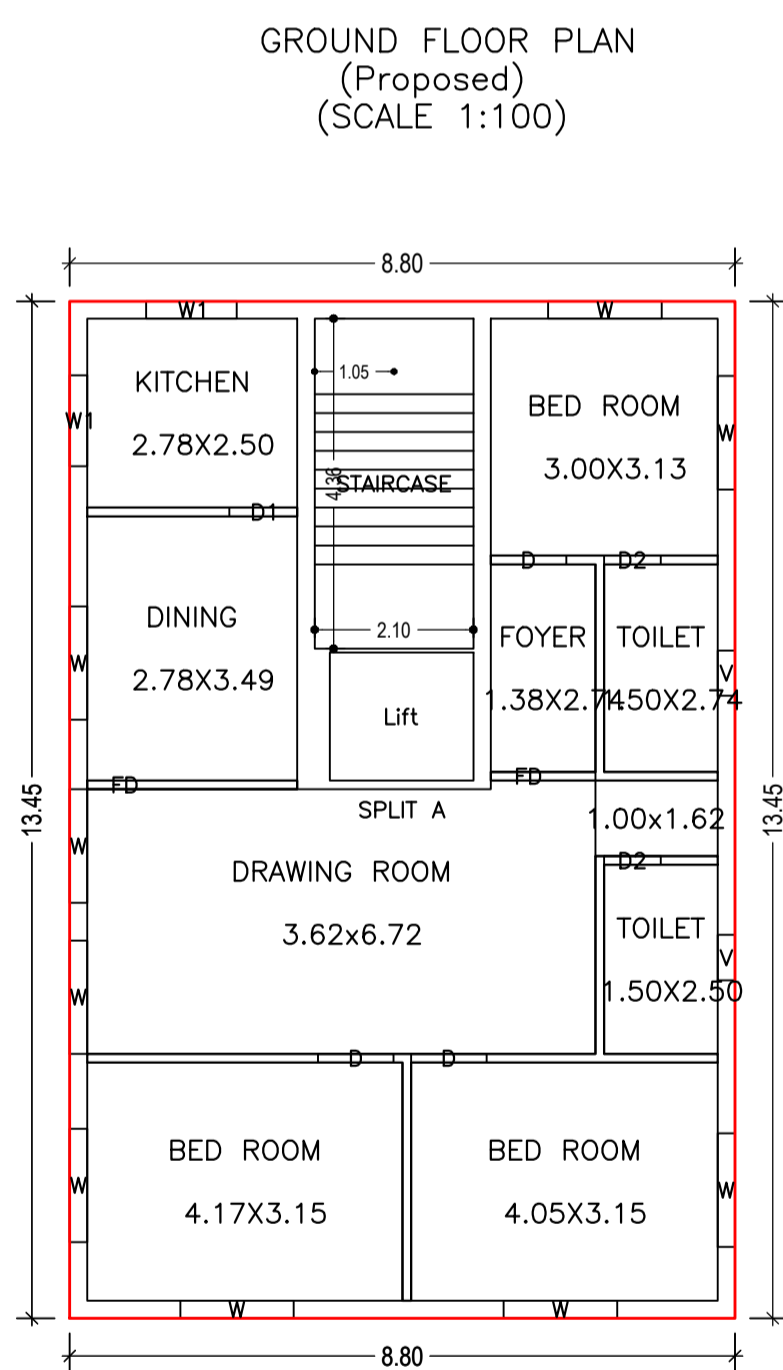
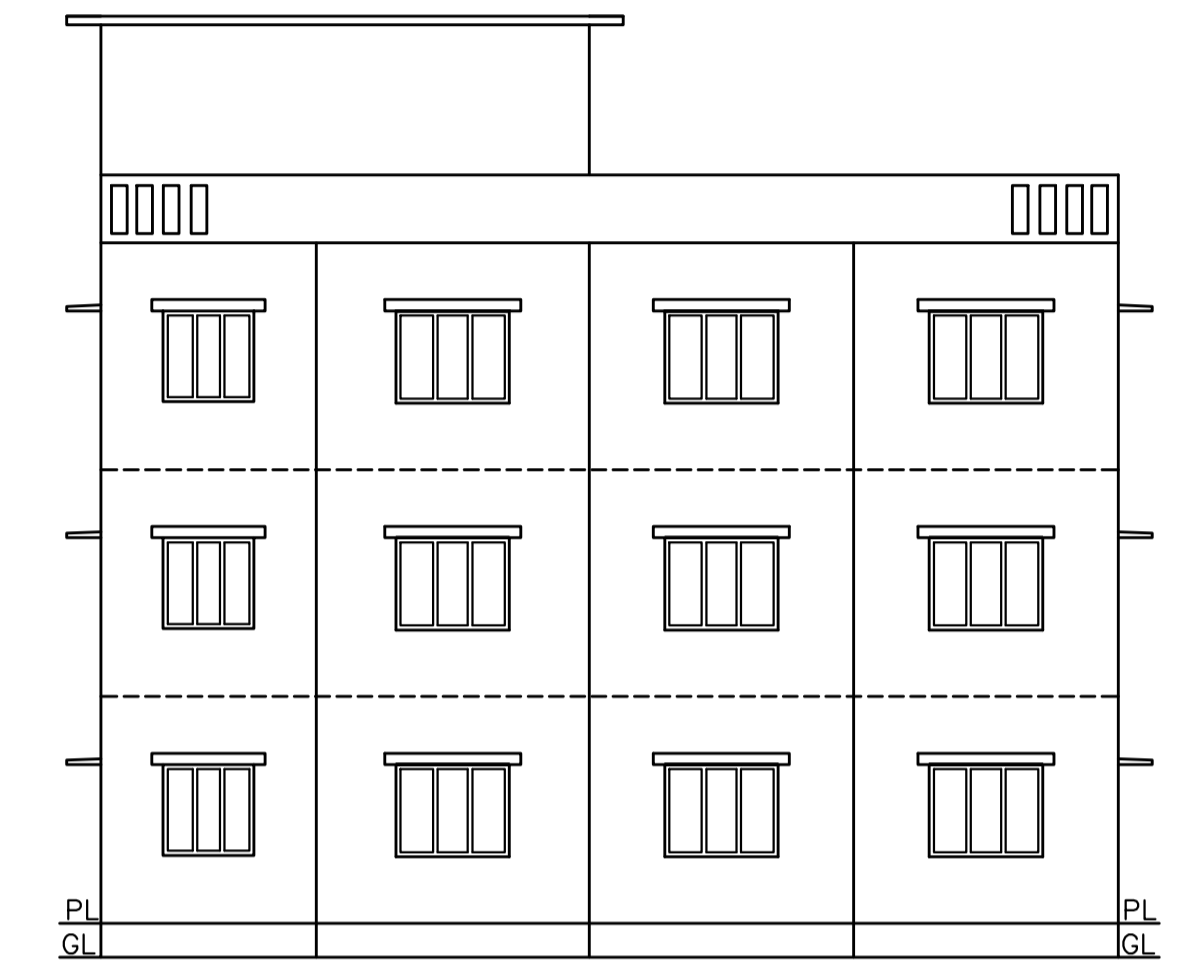
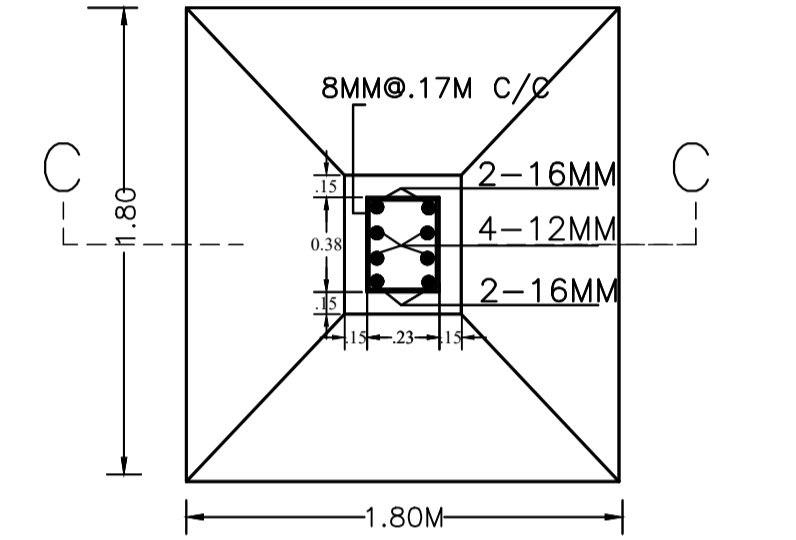
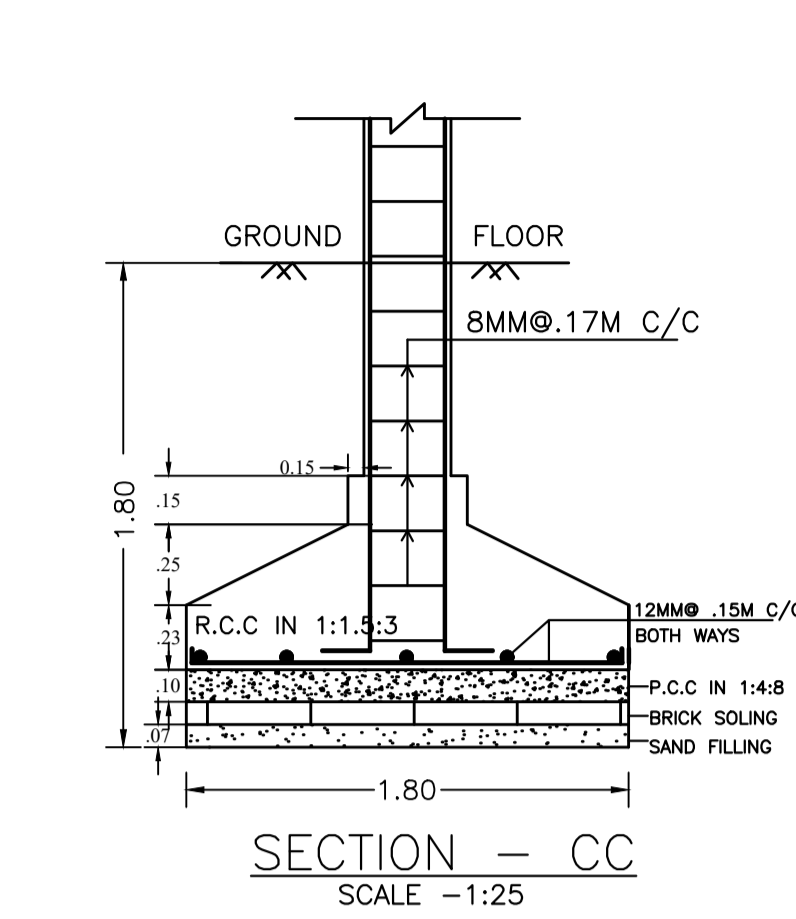
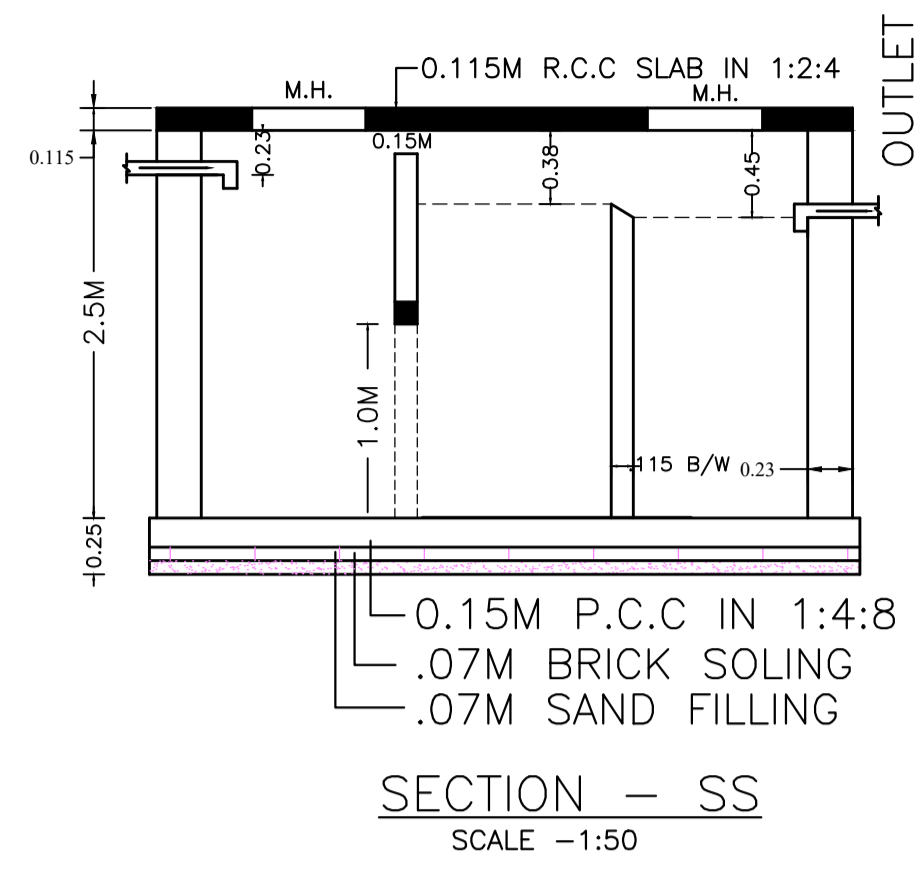
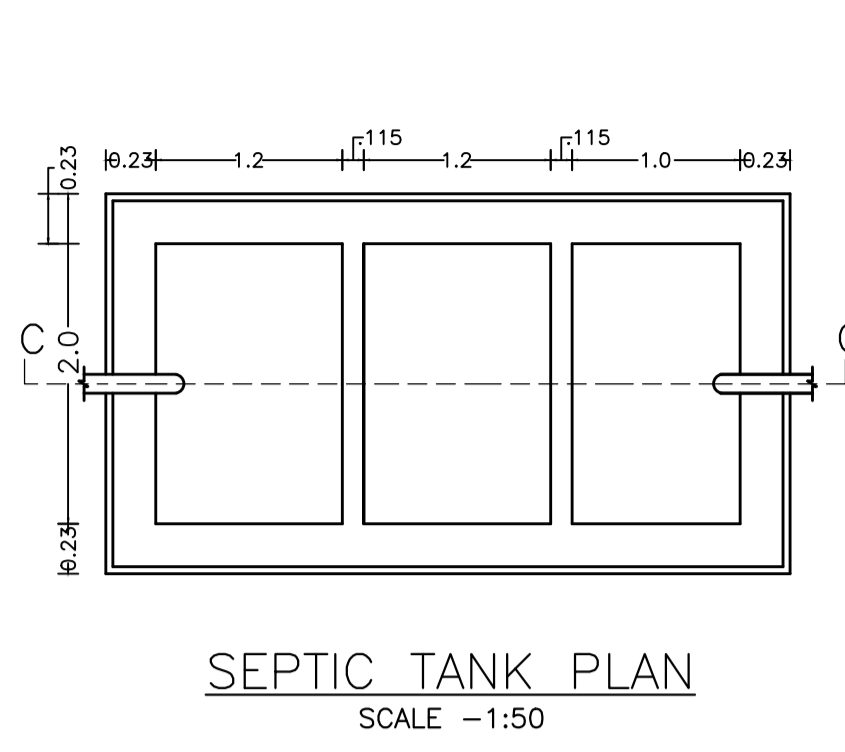
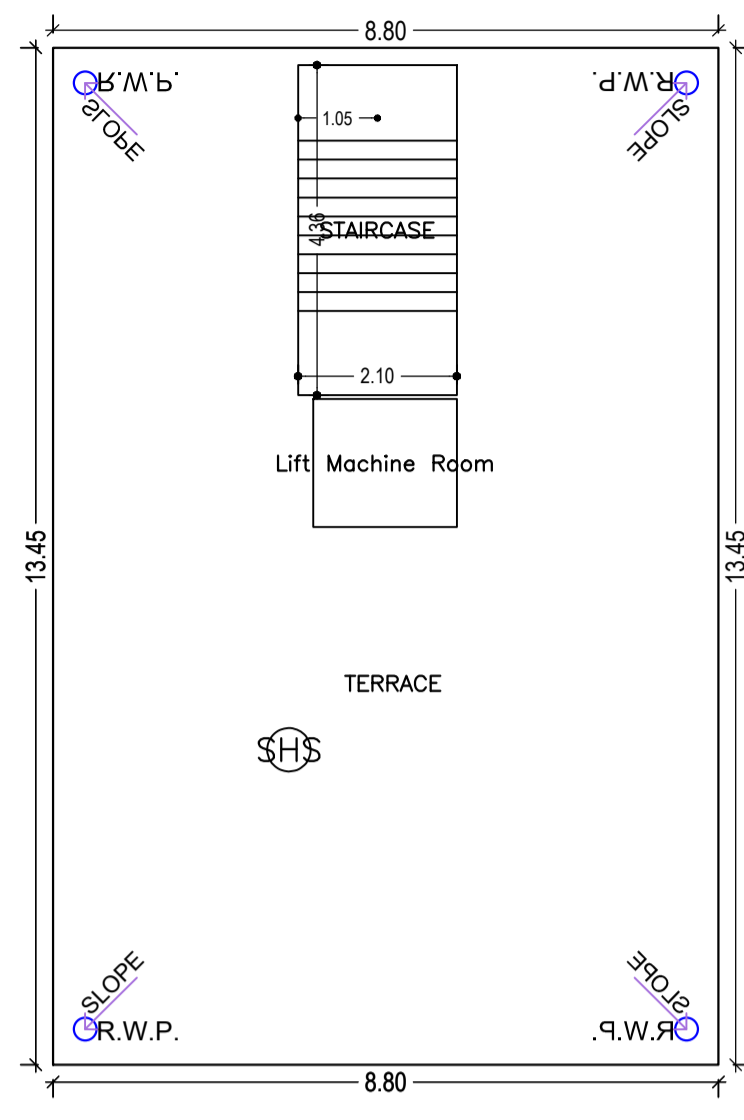
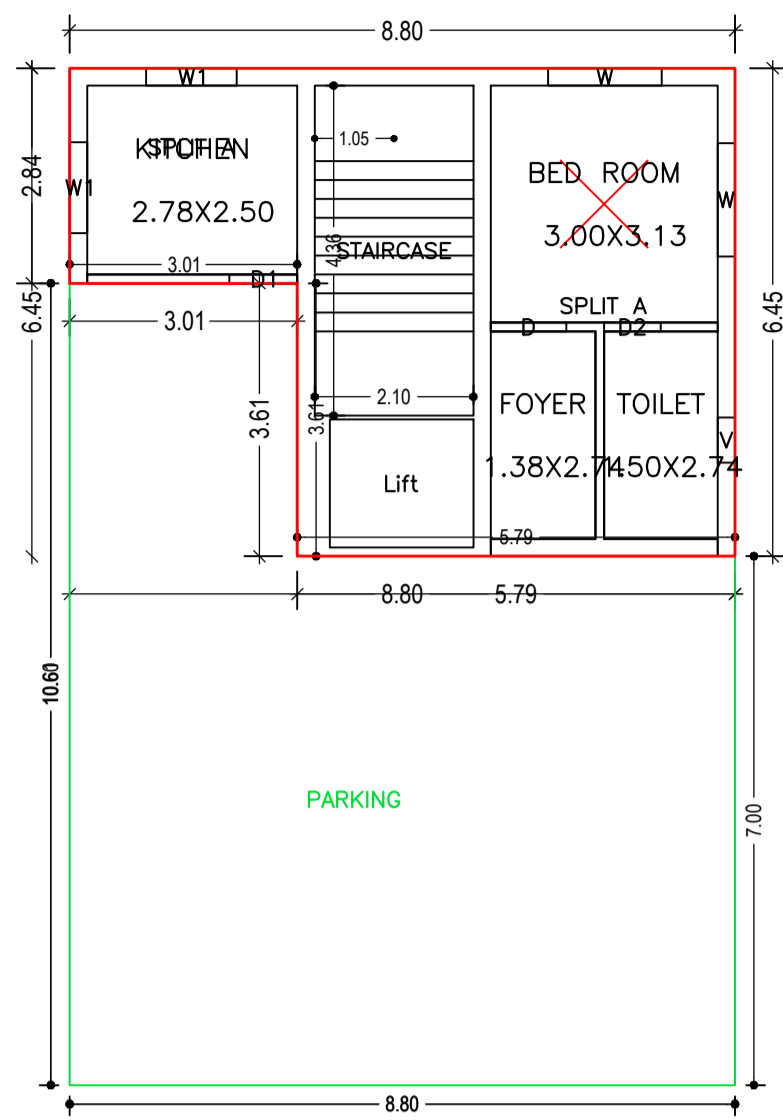

Floor Name	Total Built Up Area (Sq.mt.)	Deductions (Area in Sq.mt.)		Proposed FAR Area (Sq.mt.)	Total FAR Area (Sq.mt.)	Total Consumed Additional FAR Area (Sq.mt.)	Trmt (No.)
		Lift	Parking				
Ground Floor	118.36	0.00	72.42	45.94	45.94	45.94	01
First Floor	118.36	3.22	0.00	115.14	115.14	115.14	00
Second Floor	118.36	3.22	0.00	115.14	115.14	115.14	00
Terrace Floor	0.00	0.00	0.00	0.00	0.00	0.00	00
Total :	355.08	6.44	72.42	276.22	276.22	276.22	01
Total Number of Same Buildings	1						
Total :	355.08	6.44	72.42	276.22	276.22	276.22	01

SCHEDULE OF DOOR:

BUILDING NAME	NAME	LENGTH	HEIGHT	NOS
A (RESIDENTIAL)	D2	0.75	2.10	05
A (RESIDENTIAL)	D1	0.90	2.10	03
A (RESIDENTIAL)	D	1.00	2.10	07
A (RESIDENTIAL)	FD	1.39	2.10	02
A (RESIDENTIAL)	FD	2.78	2.10	02

SCHEDULE OF WINDOW/VENTILATION:

BUILDING NAME	NAME	LENGTH	HEIGHT	NOS
A (RESIDENTIAL)	V	0.60	0.90	05
A (RESIDENTIAL)	W1	1.20	1.20	06
A (RESIDENTIAL)	W	1.50	1.20	20

UnitBUA Table for Building :A (RESIDENTIAL)

FLOOR	Name	UnitBUA Type	UnitBUA Area	Carpet Area	No. of Rooms	No. of Tenement
GROUND FLOOR PLAN	SPLIT A	FLAT	210.75	202.20	1	1
TYPICAL -1& 2 FLOOR PLAN	SPLIT A	FLAT	0.00	0.00	3	0
Total:	-	-	210.75	202.20	22	1

LTP NAME AND SIGNATURE	STRUCTURAL ENG'S NAME AND SIGNATURE	BUILDER NAME AND SIGNATURE	DIGITAL SIGNATURE
EJAZ AHMAD MNAC/DFTMN/0008/2020			

Proposal Basic Information

Proposal File No.	MNAC/BP/0070/W09/2022
Owner Name	TRIBENI PRASAD
Khata No	584
Plot No	1030, 1031
Village Name	Pardih
Use	Residential
SubUse	Bungalow/ Dwelling / Non Apartment

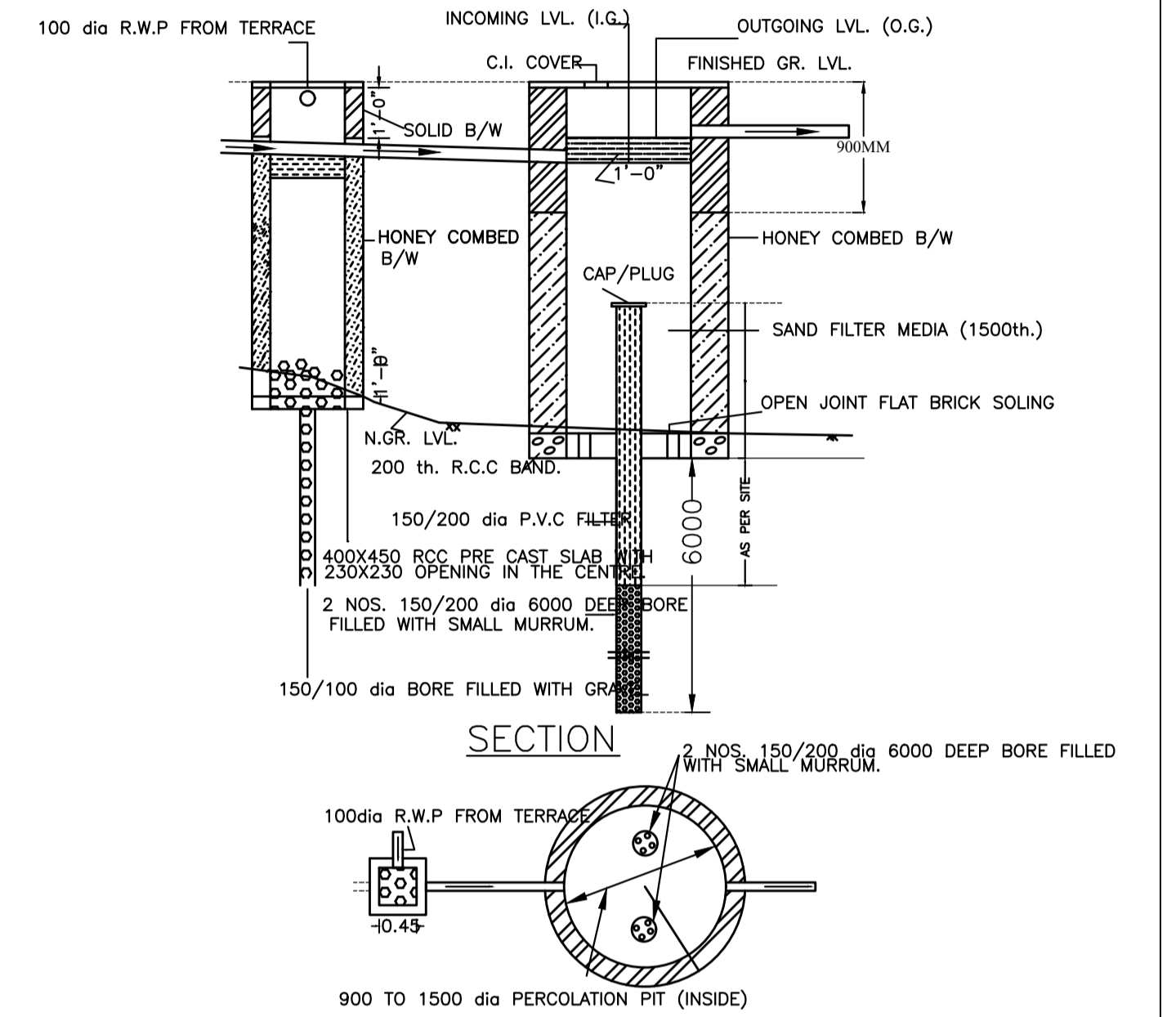

WATER HARVESTING PLAN (NTS)

LTP NAME AND SIGNATURE	STRUCTURAL ENG'S NAME AND SIGNATURE	BUILDER NAME AND SIGNATURE	DIGITAL SIGNATURE
EJAZ AHMAD MNAC/DFTMN/0008/2020			