

SITE PLAN

FAR & Tenement Details (Table 4c-1)

Building	No. of Same Bldg	Total Built Up Area (Sq.mt.)	Deductions (Area in Sq.mt.)		Proposed FAR Area (Sq.mt.)	Add Area In FAR (Sq.mt.)	Total FAR Area (Sq.mt.)	Total Consumed Additional FAR Area (Sq.mt.)	Tnmt (No.)
			Parking	Resi.					
A (RESIDENTIAL)	1	239.12	64.17	163.45	11.50	174.95	174.95	01	
Grand Total :	1	239.12	64.17	163.45	11.50	174.95	174.95	01	

Proposal Basic Information

Proposal File No.	MNAC/EP/0018/W10/2023
Owner Name	MR. ANJAY SAH
Khata No	238
Plot No	3257, 3285
Village Name	Mango
Use	Residential
SubUse	Bungalow/ Dwelling / Non Apartment

AREA STATEMENT MANGO MUNICIPAL CORPORATION		VERSION NO. : 1.0.66
PROJECT DETAIL:		VERSION DATE: 16/10/2020
Region: JHARKHAND URBAN LOCAL BODIES	Plot Use: Residential	
District: EAST SINGHBHUM	Plot SubUse: Bungalow/ Dwelling / Non Apartment	
Authority: MANGO MUNICIPAL CORPORATION	PlotNearbyReligiousStructure: NA	
Inward No: MNAC/EP/0018/W10/2023	PlotSubPlot No: 3257, 3285	
Application Type: General Proposal	North: Road Width - 4.80	
Project Type: Building Permission	South: Plot No. - 3285	
Nature of Development: New	East: Road Width - 4.80	
Location of Development Area: Old Area	West: Plot No. - 3285	
AREA DETAILS:		
AREA OF PLOT (Minimum)	(A)	SQ.MT. 132.98
NET AREA OF PLOT(Gross Plot Area - Deduction from Gross Plot area)	(A-Deductions)	132.98
Deduction for Balance Plot Area(from Gross Plot Area)		
Common Plot		13.43
Total		13.43
BALANCE AREA OF PLOT(Net Plot Area - Recreational/Amenity space)	(A-Deductions)	119.55
PLOT AREA FOR COVERAGE(Net Plot Area)	(A-Deductions)	132.98
Plot Area for FAR (Net Plot Area + Road Widening Area)	(A-Deductions)	132.98
COVERAGE CHECK		
Permissible Coverage area (70.00 %)		93.09
Proposed Coverage Area (59.94 %)		79.71
Total Prop. Coverage Area (59.94 %)		79.71
Balance coverage area (10.06 %)		13.38
FAR CHECK		
Perm. FAR Area (1.800)		239.36
Total Perm. FAR area		239.36
Residential FAR		163.44
Proposed FAR Area		174.94
Total Proposed FAR Area		174.94
Consumed FAR (Factor)		1.32
Balance FAR Area		64.42
BUILT UP AREA CHECK		
Total Proposed BuiltUp Area		239.12
ARCHITECT (Regd)	Chandrika Sharma	
ENGINEER (Regd)		
SUPERVISOR (Regd)		
OWNER (Regd)	MR. ANJAY SAH	
DEVELOPMENT AUTHORITY		LOCAL BODY

COLOR INDEX	
PLOT BOUNDARY	Black
ABUTTING ROAD	Green
PROPOSED CONSTRUCTION	Red
COMMON PLOT	Yellow
ROAD WIDENING AREA	Light Blue
EXISTING (To be retained)	Blue
EXISTING (To be demolished)	Light Yellow

Buildingwise Floor FAR Details

Floor Name	Building Name A (RESIDENTIAL)		Total	
	Proposed Built Up Area (Sq.mt.)	Proposed FAR Area (Sq.mt.)	Total Proposed Built Up Area (Sq.mt.)	Total FAR Area (Sq.mt.)
Ground Floor	79.70	15.53	79.70	15.53
First Floor	79.71	79.71	79.71	79.71
Second Floor	79.71	79.71	79.71	79.71
Terrace Floor	0.00	0.00	0.00	0.00
Total :	239.12	174.95	239.12	174.95

Building USE/SUBUSE Details

Building Name	Building Use	Building SubUse	Building Structure
A (RESIDENTIAL)	Residential	Bungalow/ Dwelling / Non Apartment	Non-Highrise

LTP NAME AND SIGNATURE	STRUCTURAL ENG'S NAME AND SIGNATURE	BUILDER NAME AND SIGNATURE	DIGITAL SIGNATURE
Chandrika Sharma MNAC/DFTMN/0017/2017			

Proposal Basic Information	
Proposal File No.	MNAC/EP/10018/W10/2023
Owner Name	MR. ANJAY SAH
Khata No	238
Plot No	3257, 3285
Village Name	Mango
Use	Residential
SubUse	Bungalow/ Dwelling / Non Apartment

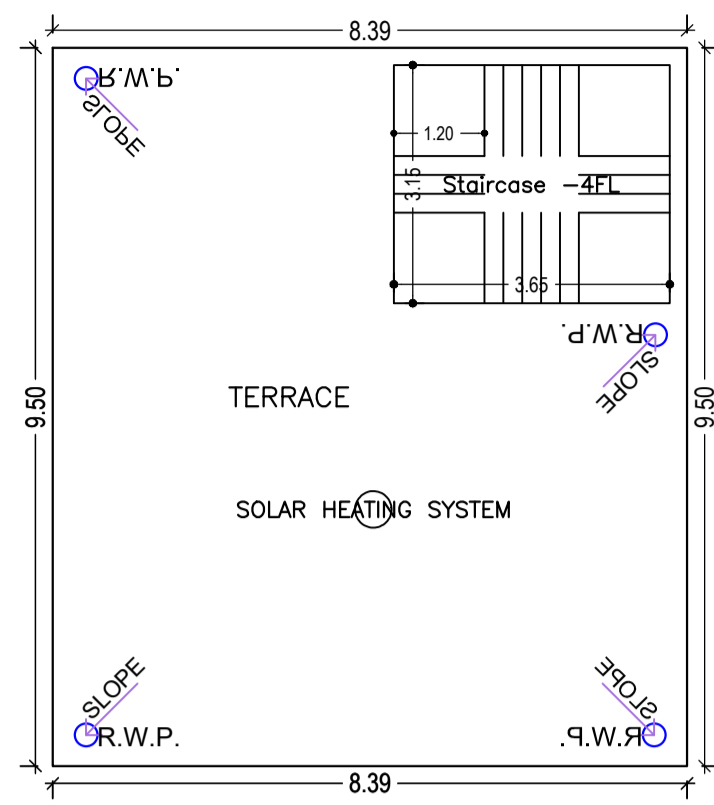
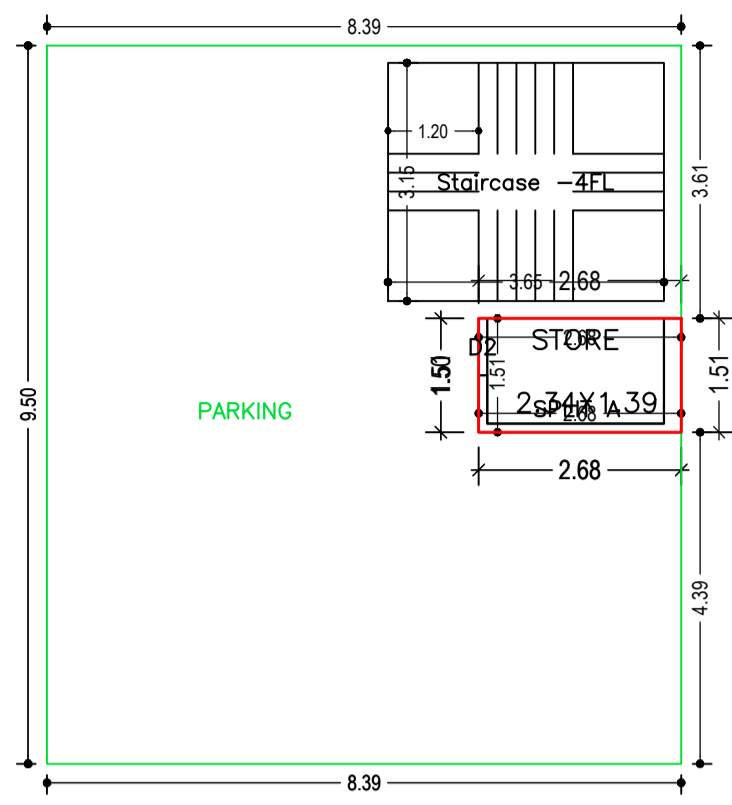

TERRACE FLOOR PLAN (SCALE 1:100)

GROUND FLOOR PLAN (Proposed) (SCALE 1:100)

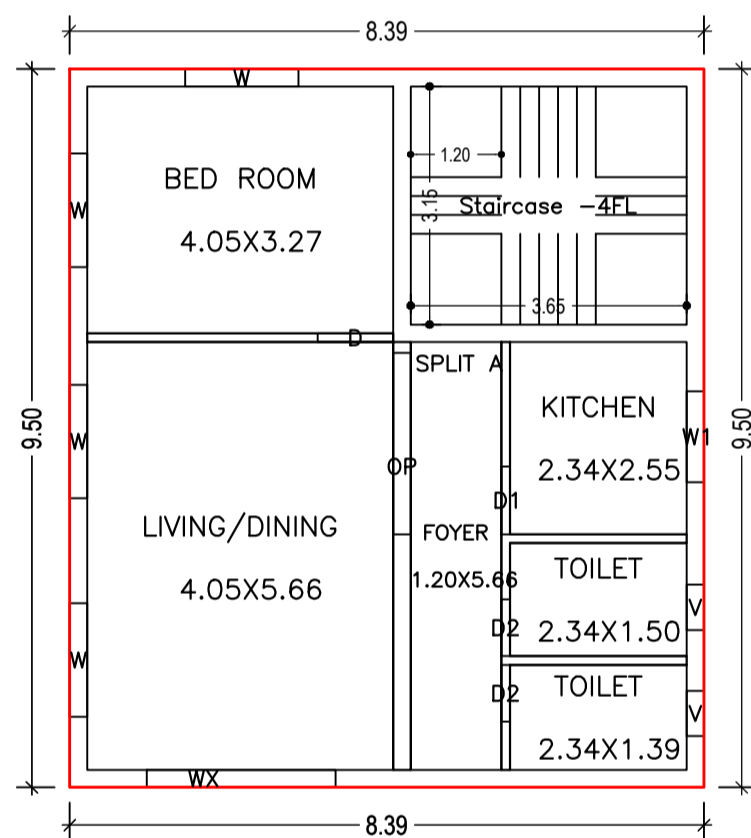

TYPICAL - 1& 2 FLOOR PLAN (Proposed) (SCALE 1:100)

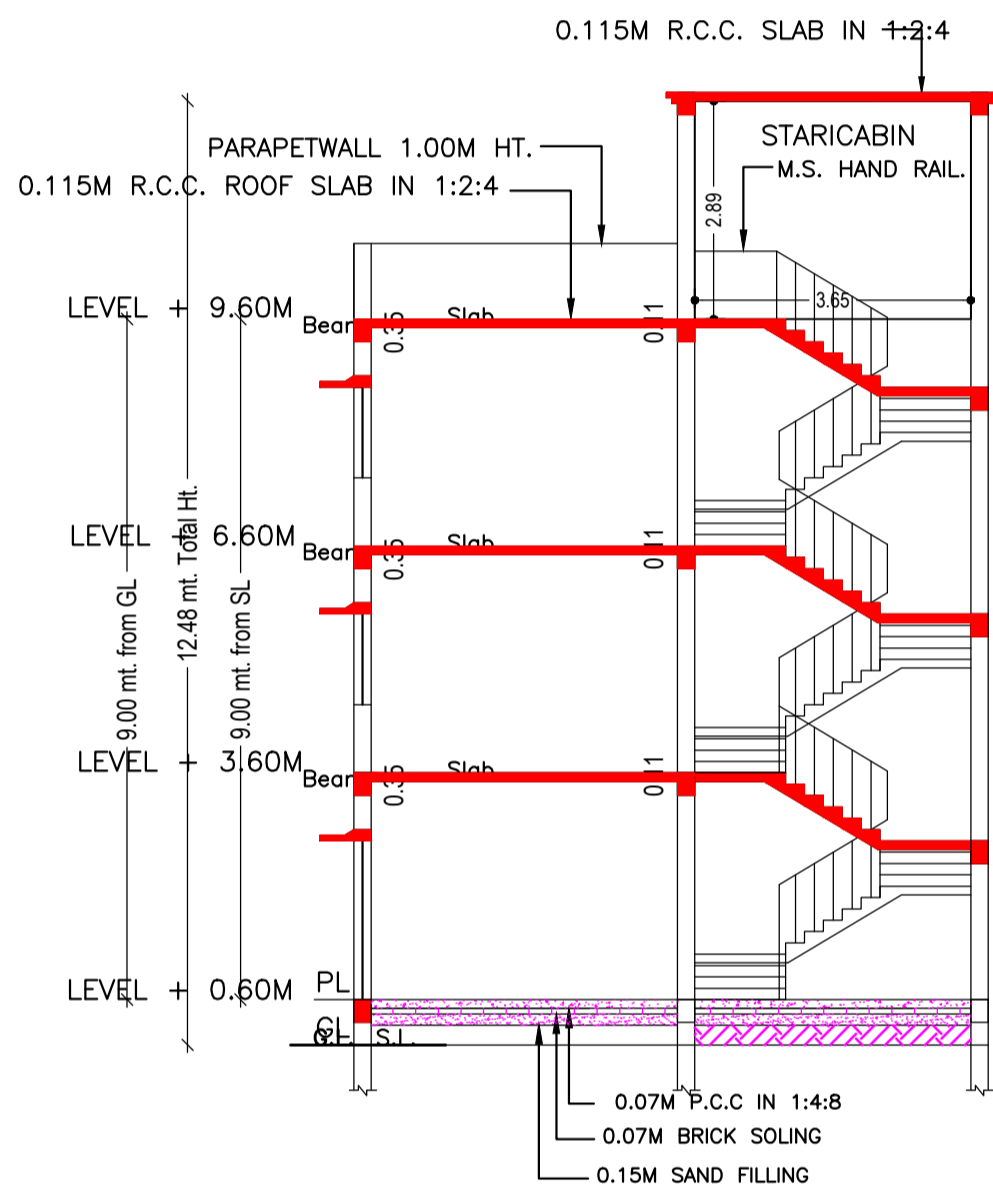

SECTION A A (SCALE 1:100)

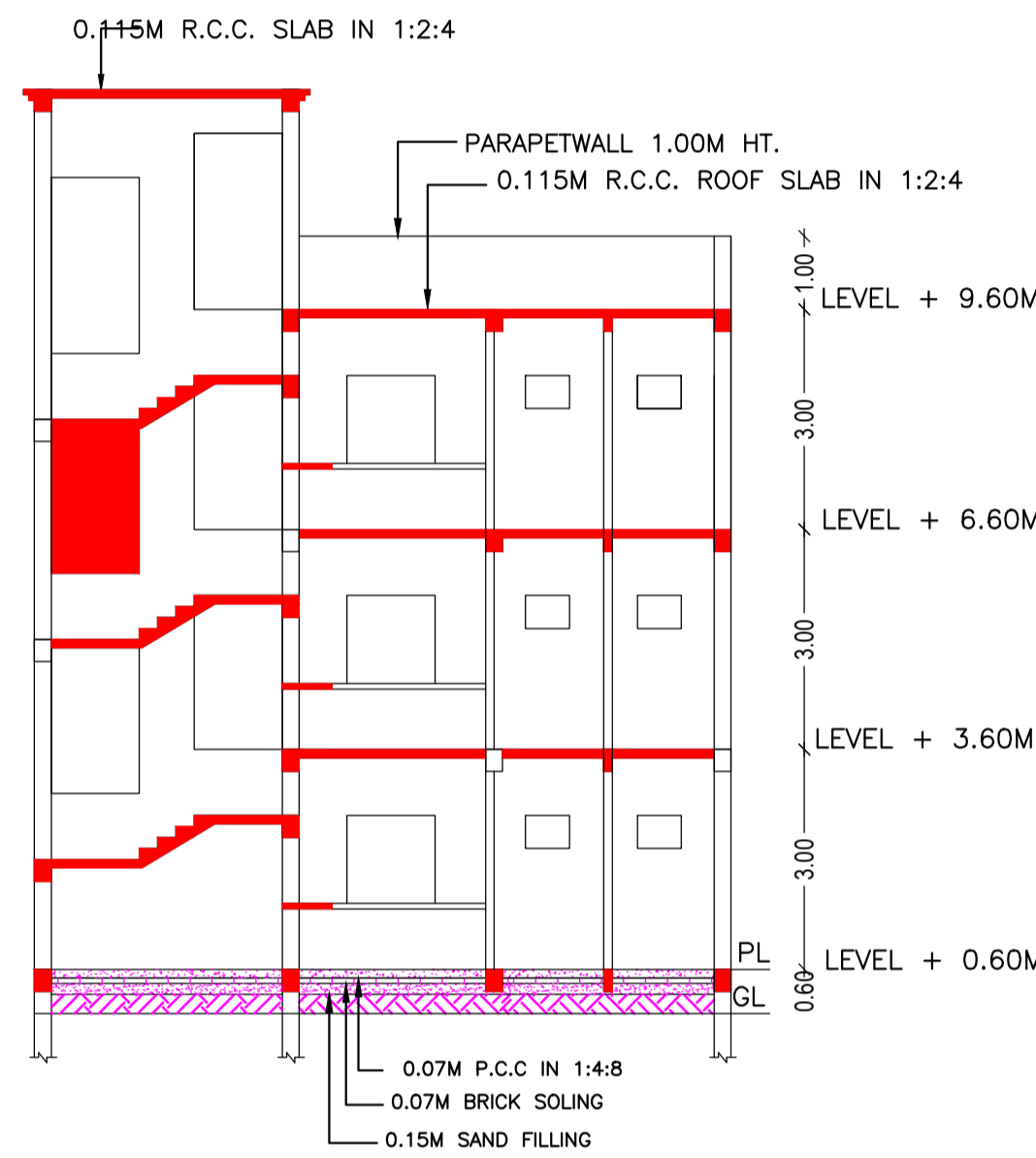

SECTION B B (SCALE 1:100)

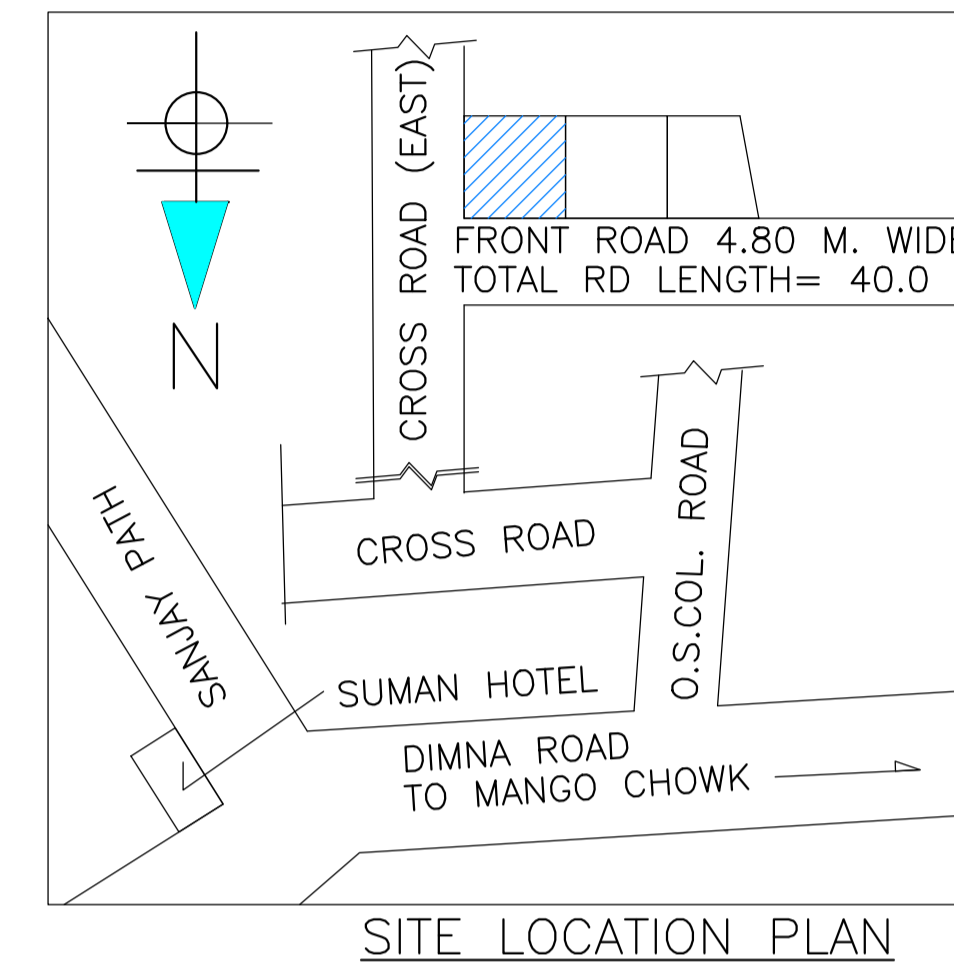

SITE LOCATION PLAN

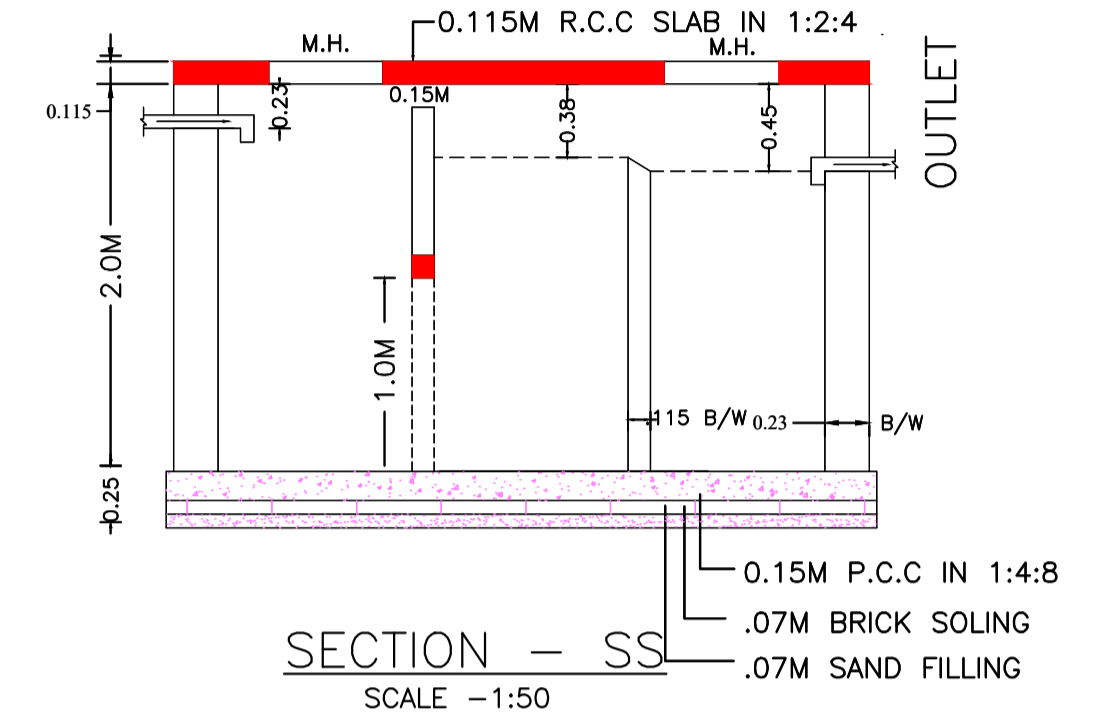

SECTION - SS (SCALE -1:50)

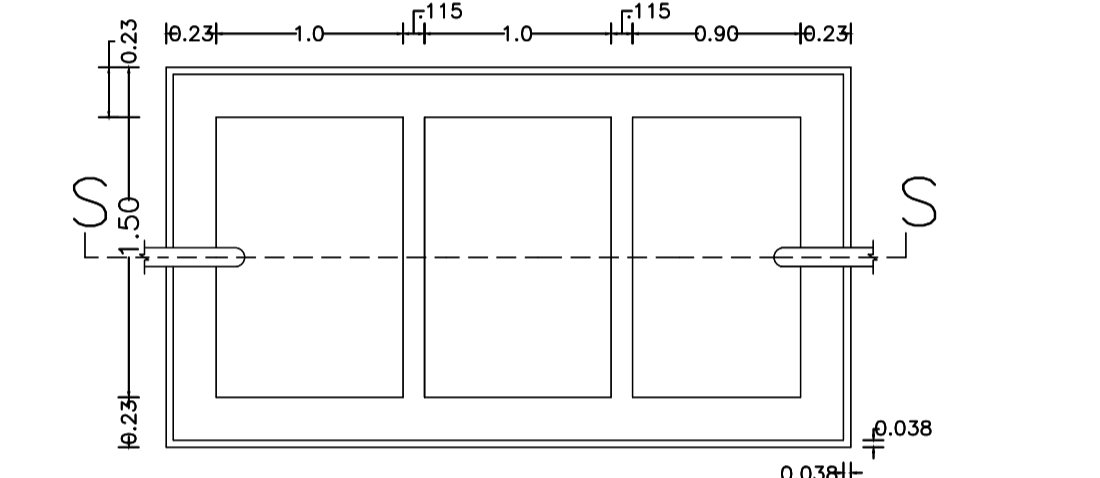

SEPTIC TANK PLAN

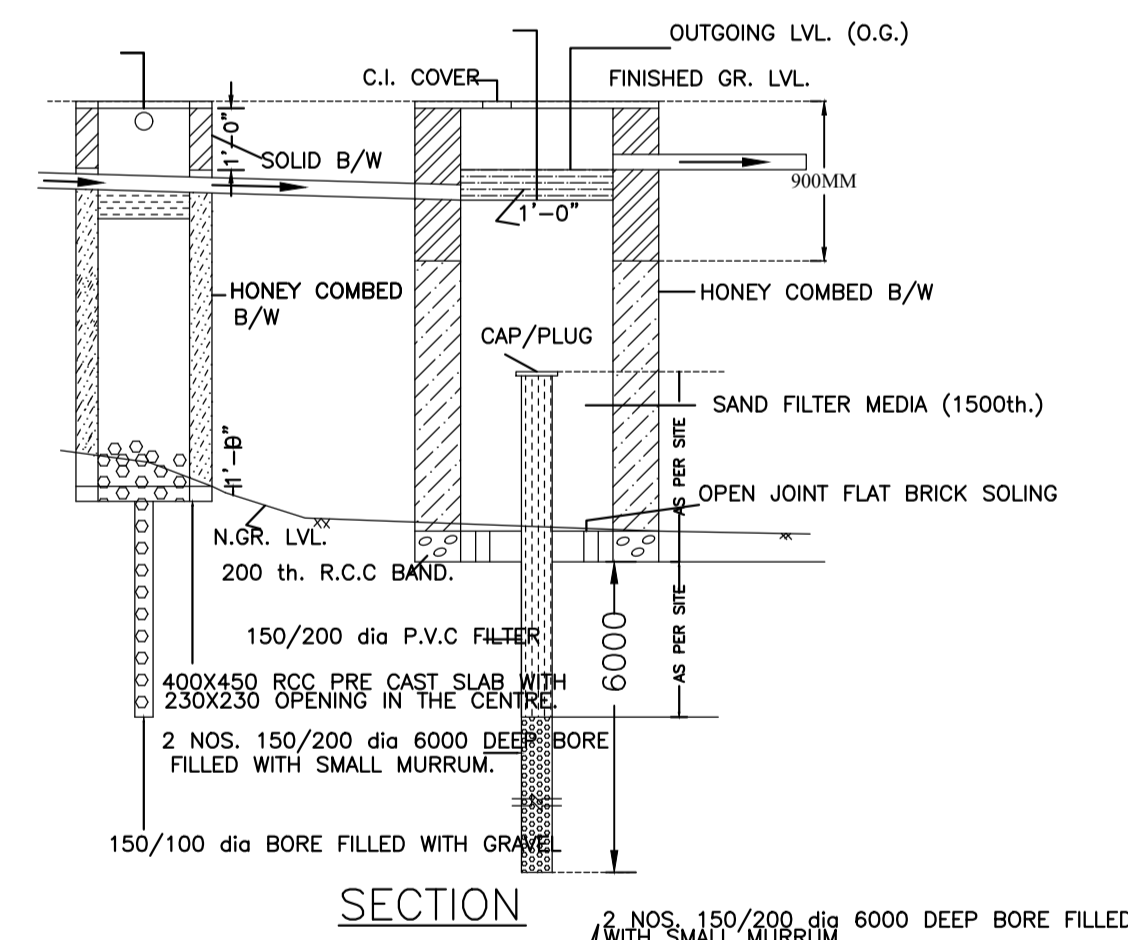

SECTION

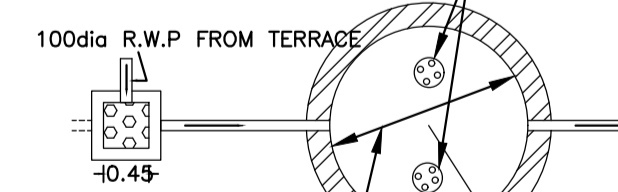

WATER HARVESTING PLAN (NTS)

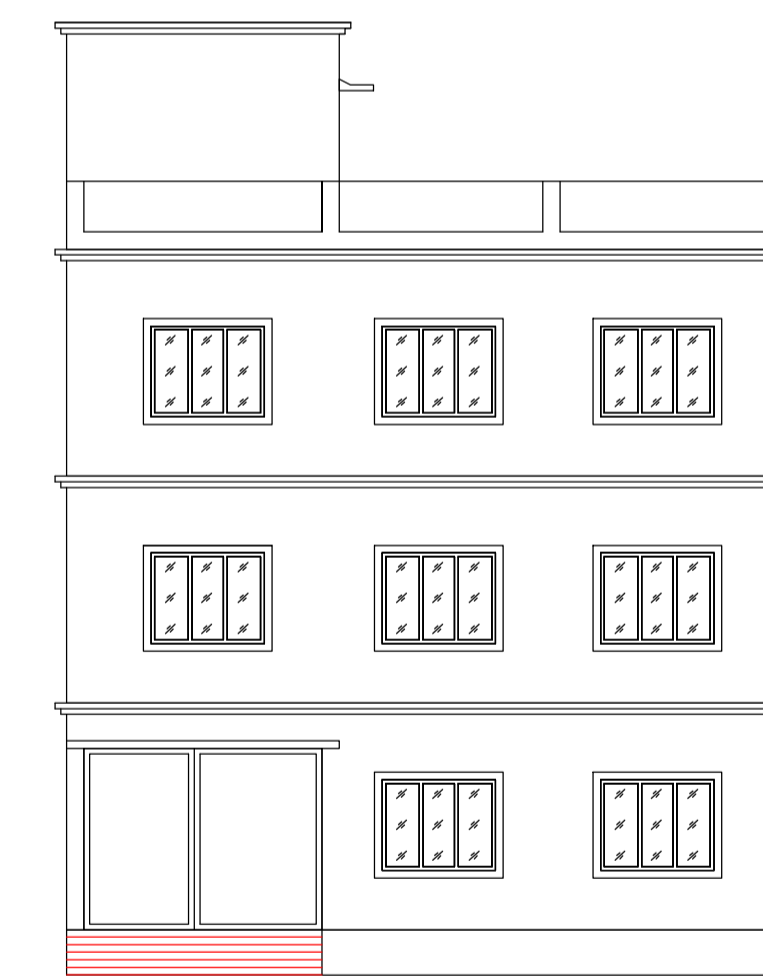

EAST SIDE ELEVATION (SCALE 1:100)

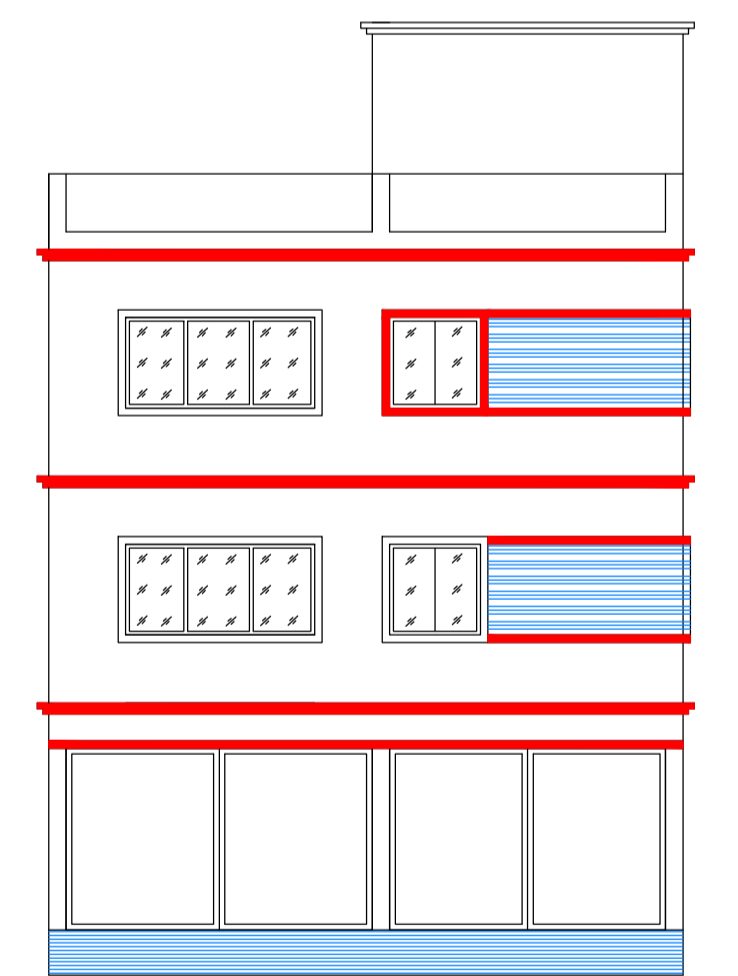

FRONT ELEVATION (SCALE 1:100)

Building :A (RESIDENTIAL)

Floor Name	Total Built Up Area (Sq.mt.)	Deductions (Area in Sq.mt.)	Proposed FAR Area (Sq.mt.)	Add Area in FAR (Sq.mt.)	Total FAR Area (Sq.mt.)	Total Consumed Additional FAR Area (Sq.mt.)	Trmt (No.)
Ground Floor	79.70	64.17	4.03	11.50	15.53	15.53	01
First Floor	79.71	0.00	79.71	0.00	79.71	79.71	00
Second Floor	79.71	0.00	79.71	0.00	79.71	79.71	00
Terrace Floor	0.00	0.00	0.00	0.00	0.00	0.00	00
Total :	239.12	64.17	163.45	11.50	174.95	174.95	01
Total Number of Same Buildings	1						
Total :	239.12	64.17	163.45	11.50	174.95	174.95	01

SCHEDULE OF DOOR:

BUILDING NAME	NAME	LENGTH	HEIGHT	NOS
A (RESIDENTIAL)	D2	0.75	2.10	05
A (RESIDENTIAL)	D1	0.90	2.10	02
A (RESIDENTIAL)	D	1.00	2.10	02
A (RESIDENTIAL)	OP	2.40	2.10	02

SCHEDULE OF WINDOW/VENTILATION:

BUILDING NAME	NAME	LENGTH	HEIGHT	NOS
A (RESIDENTIAL)	V	0.60	0.90	04
A (RESIDENTIAL)	W1	1.20	1.20	02
A (RESIDENTIAL)	W	1.50	1.20	08
A (RESIDENTIAL)	WX	2.50	1.20	02

UnitBUA Table for Building :A (RESIDENTIAL)

FLOOR	Name	UnitBUA Type	UnitBUA Area	Carpet Area	No. of Rooms	No. of Tenement
GROUND FLOOR PLAN	SPLIT A	FLAT	121.18	114.57	1	1
TYPICAL - 1& 2 FLOOR PLAN	SPLIT A	FLAT	0.00	0.00	6	0
Total:	-	-	121.18	114.57	13	1

LTP NAME AND SIGNATURE	STRUCTURAL ENG'S NAME AND SIGNATURE	BUILDER NAME AND SIGNATURE	DIGITAL SIGNATURE
Chandrika Sharma MNAC/DFTMN/0017/2017			

Proposal Basic Information	
Proposal File No.	MNAC/EP/0018/W10/2023
Owner Name	MR. ANJAY SAH
Khata No	238
Plot No	3257, 3285
Village Name	Mango
Use	Residential
SubUse	Bungalow/ Dwelling / Non Apartment

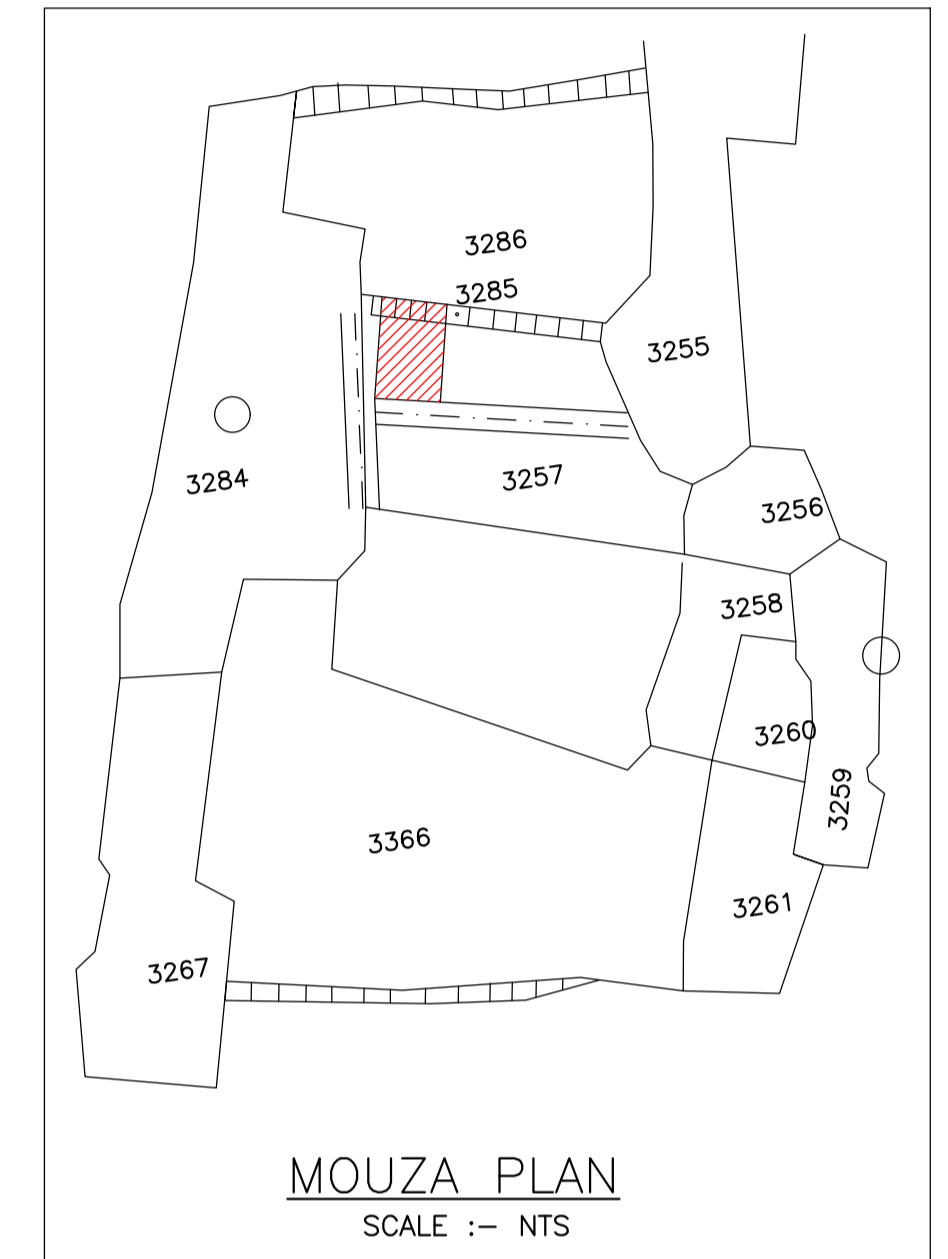
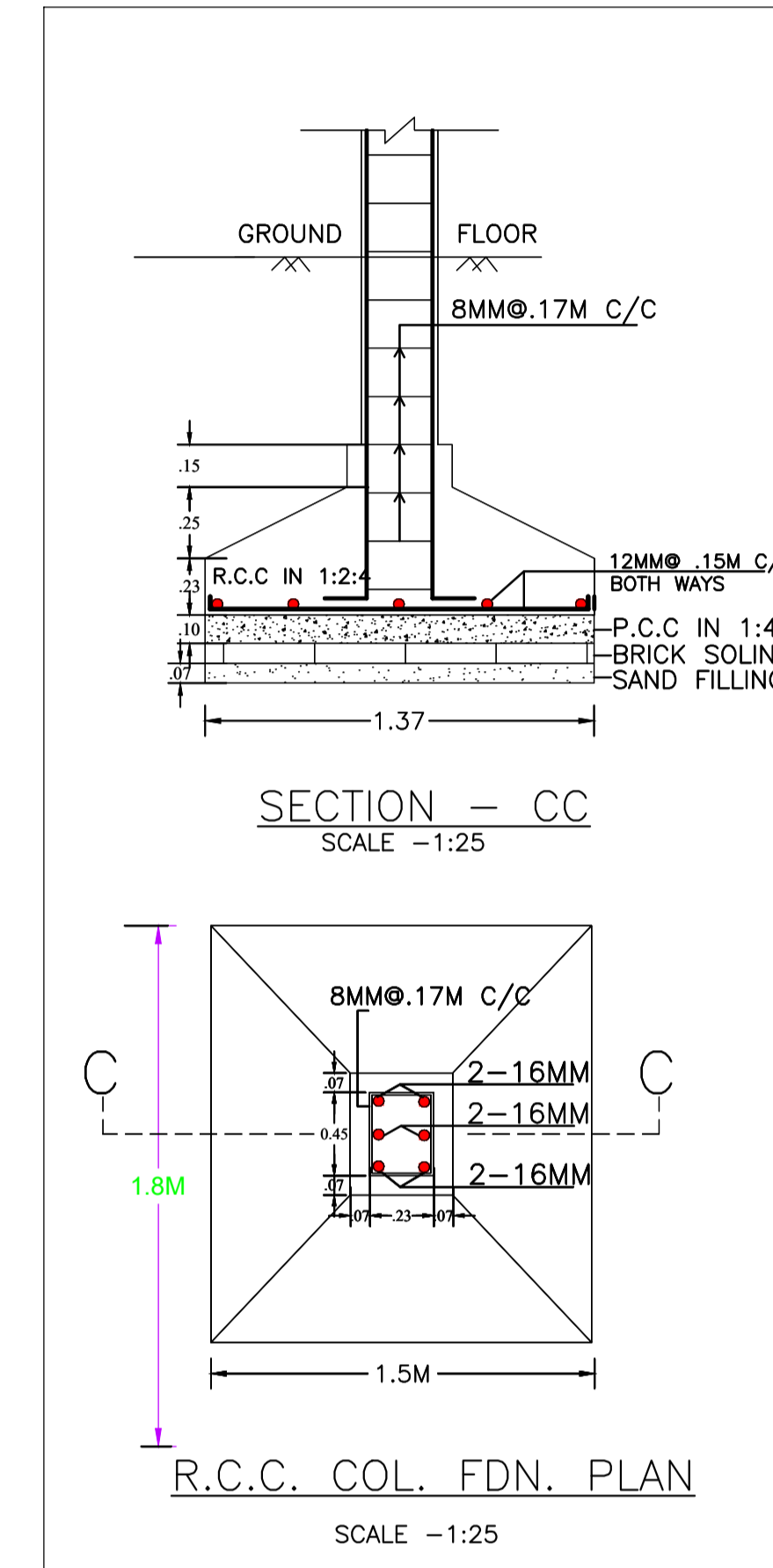

LTP NAME AND SIGNATURE	STRUCTURAL ENG'S NAME AND SIGNATURE	BUILDER NAME AND SIGNATURE	DIGITAL SIGNATURE
Chandrika Sharma MNAC/DFTMN/0017/2017			