

SITE PLAN
SCALE 1:100

FAR & Tenement Details (Table 4c-1)

Building	No. of Same Bldg	Total Built Up Area (Sq.mt.)	Deductions (Area in Sq.mt.) Parking	Proposed FAR Area (Sq.mt.) Resi.	Total FAR Area (Sq.mt.)	Total Consumed Additional FAR Area (Sq.mt.)	Tnmt (No.)
A (RESIDENTIAL)	1	231.45	13.80	217.65	217.65	217.65	01
Grand Total :	1	231.45	13.80	217.65	217.65	217.65	01

Proposal Basic Information

Proposal File No.	MNAC/BP/0019/W09/2023
Owner Name	1. SHIVJEE KUNWAR 2. SANTOSH KUNWAR 3. SATYENDRA KUNWAR
Khata No	286
Plot No	4637
Village Name	Mango
Use	Residential
SubUse	Bungalow/ Dwelling / Non Apartment

AREA STATEMENT MANGO MUNICIPAL CORPORATION	VERSION NO.: 1.0.66	VERSION DATE: 16/10/2020
PROJECT DETAIL:	Plot Use: Residential	
Region: JHARKHAND URBAN LOCAL BODIES	Plot SubUse: Bungalow/ Dwelling / Non Apartment	
District: EAST SINGBHUM	PlotNearbyReligiousStructure: NA	
Authority: MANGO MUNICIPAL CORPORATION	Plot/SubPlot No: 4637	
Inward No: MNAC/BP/0019/W09/2023	North: -	
Application Type: General Proposal	South: -	
Project Type: Building Permission	East: -	
Nature of Development: New	West: -	
Location of Development Area: Old Area	-	
AREA DETAILS:	SQ.MT.	
AREA OF PLOT (Minimum)	(A)	195.47
NET AREA OF PLOT(Gross Plot Area - Deduction from Gross Plot area)	(A-Deductions)	195.47
Deduction for Balance Plot Area(from Gross Plot Area)		
Common Plot		20.84
BALANCE AREA OF PLOT(Net Plot Area - Recreational/Amenity space)	(A-Deductions)	174.63
PLOT AREA FOR COVERAGE(Net Plot Area)	(A-Deductions)	195.47
Plot Area for FAR (Net Plot Area + RoadWidening Area)	(A-Deductions)	195.47
COVERAGE CHECK		
Permissible Coverage area (70.00 %)		136.83
Proposed Coverage Area (59.21 %)		115.73
Total Prop. Coverage Area (59.21 %)		115.73
Balance coverage area (10.79 %)		21.10
FAR CHECK		
Perm. FAR Area (1.500)		293.21
Total Perm. FAR area		293.21
Residential FAR		217.65
Proposed FAR Area		217.65
Total Proposed FAR Area		217.65
Consumed FAR (Factor)		1.11
Balance FAR Area		75.56
BUILT UP AREA CHECK		
Total Proposed BuiltUp Area		231.45
ARCHITECT (Regd)	EJAZ AHMAD	
ENGINEER (Regd)		
SUPERVISOR (Regd)		
OWNER (Regd)	1. SHIVJEE KUNWAR 2. SANTOSH KUNWAR 3. SATYENDRA KUNWAR	
DEVELOPMENT AUTHORITY	LOCAL BODY	

COLOR INDEX	
PLOT BOUNDARY	Black
ABUTTING ROAD	Green
PROPOSED CONSTRUCTION	Red
COMMON PLOT	Yellow
ROAD WIDENING AREA	Orange
EXISTING (To be retained)	Blue
EXISTING (To be demolished)	Light Blue

Buildingwise Floor FAR Details

Floor Name	Building Name A (RESIDENTIAL)		Total	
	Proposed Built Up Area (Sq.mt.)	Proposed FAR Area (Sq.mt.)	Total Proposed Built Up Area (Sq.mt.)	Total FAR Area (Sq.mt.)
Ground Floor	115.72	101.92	115.72	101.92
First Floor	115.73	115.73	115.73	115.73
Terrace Floor	0.00	0.00	0.00	0.00
Total :	231.45	217.65	231.45	217.65

Building USE/SUBUSE Details

Building Name	Building Use	Building SubUse	Building Structure
A (RESIDENTIAL)	Residential	Bungalow/ Dwelling / Non Apartment	Non-Highrise

LTP NAME AND SIGNATURE	STRUCTURAL ENG'S NAME AND SIGNATURE	BUILDER NAME AND SIGNATURE	DIGITAL SIGNATURE
EJAZ AHMAD MNAC/DFTMN/0008/2020			

Proposal Basic Information	
Proposal File No.	MNAC/BI/0019/W09/2023
Owner Name	1. SHIVJEE KUNWAR 2. SANTOSH KUNWAR 3. SATYEN KUNWAR
Khata No	286
Plot No	4637
Village Name	Mango
Use	Residential
SubUse	Bungalow/ Dwelling / Non Apartment

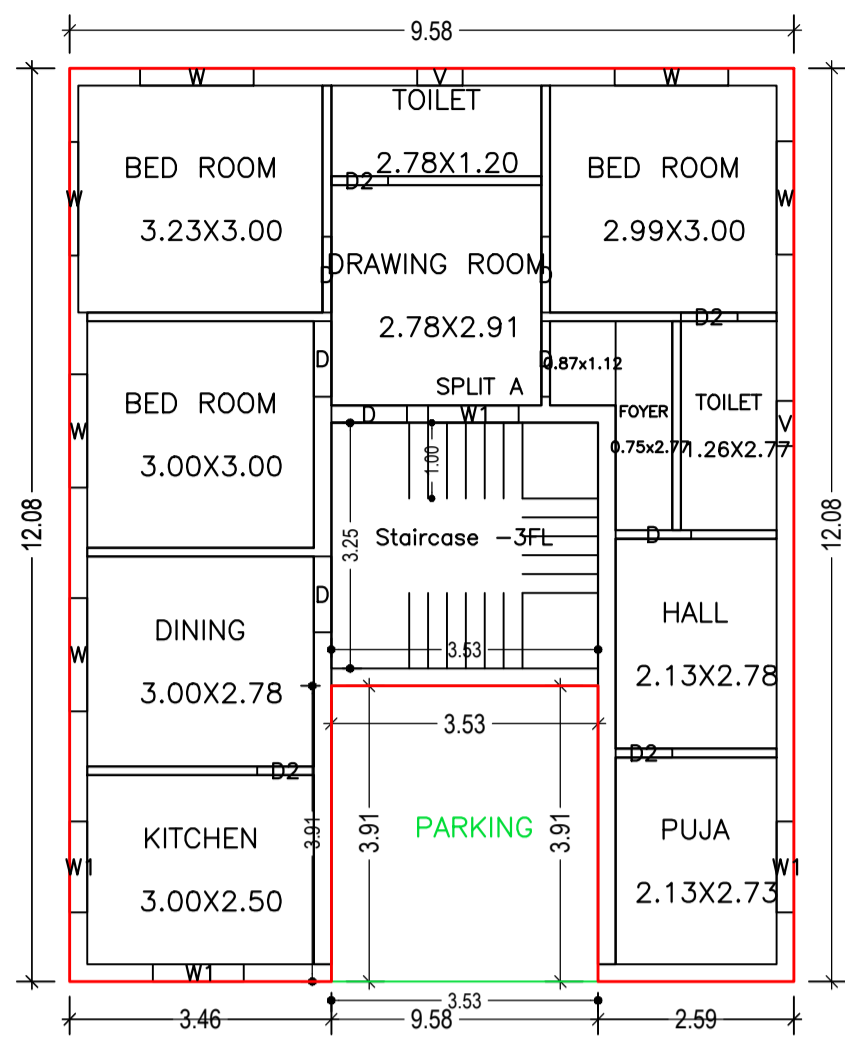

TERRACE FLOOR PLAN (SCALE 1:100)

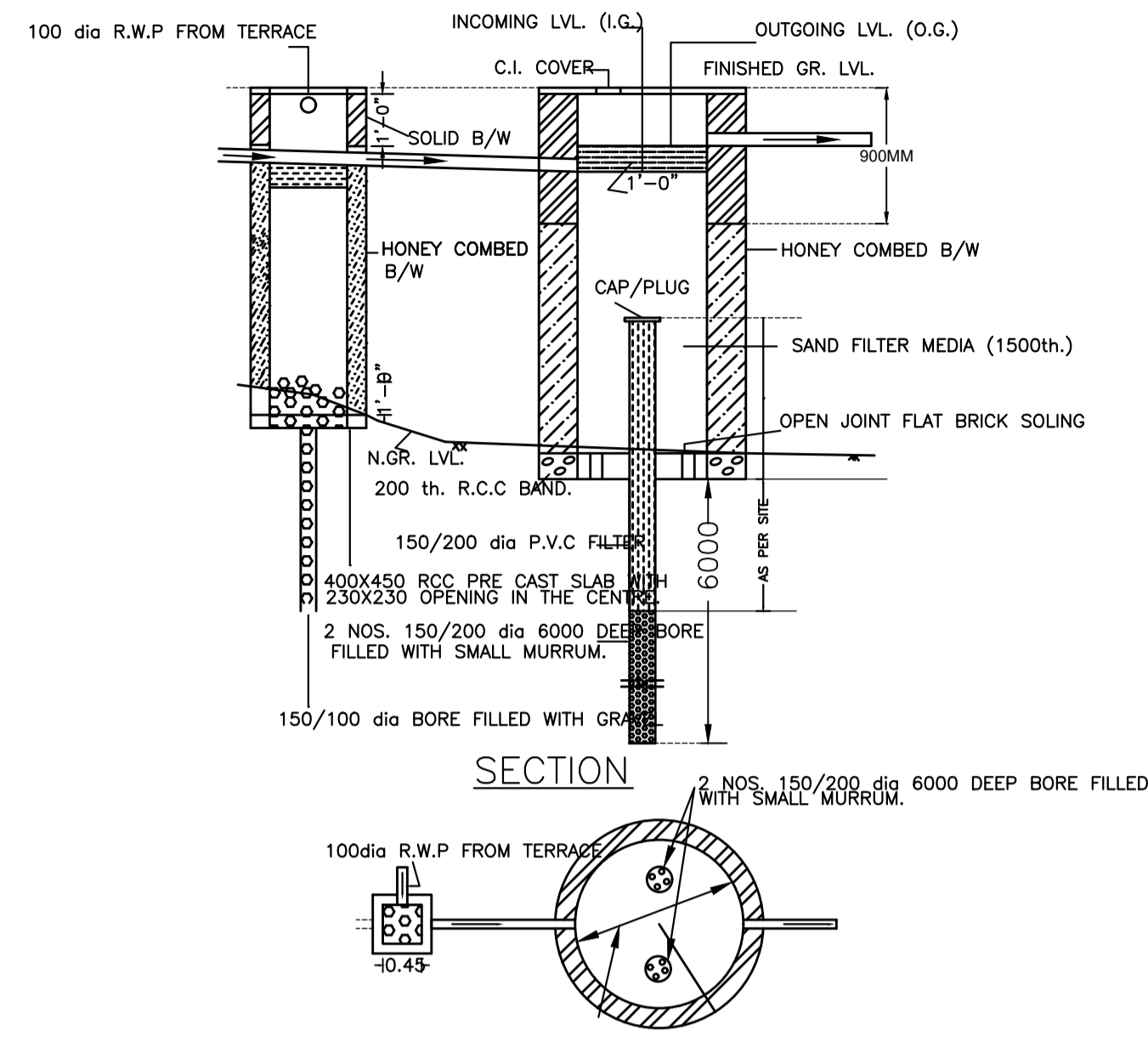

SECTION

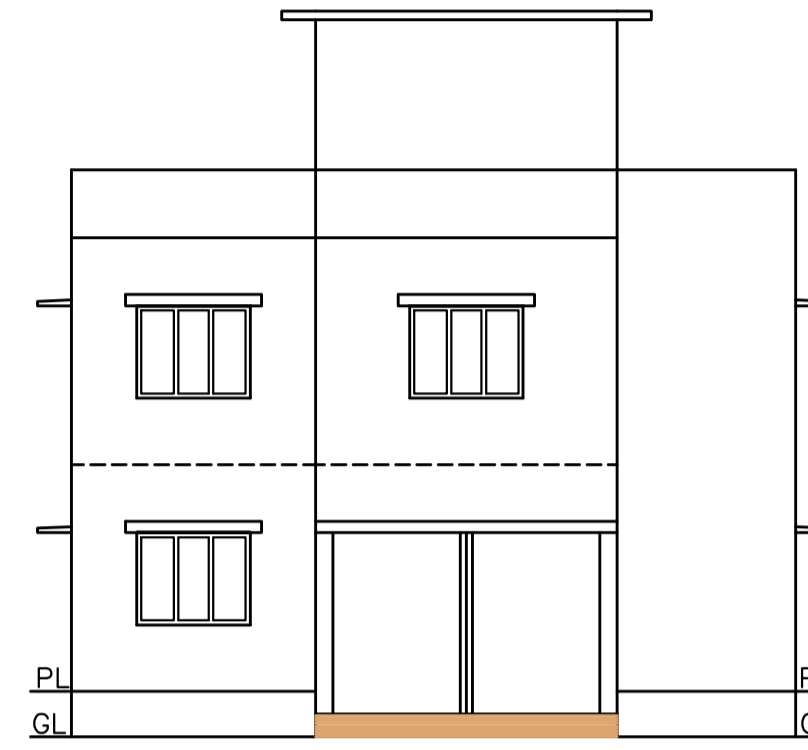

FRONT ELEVATION SCALE 1:100

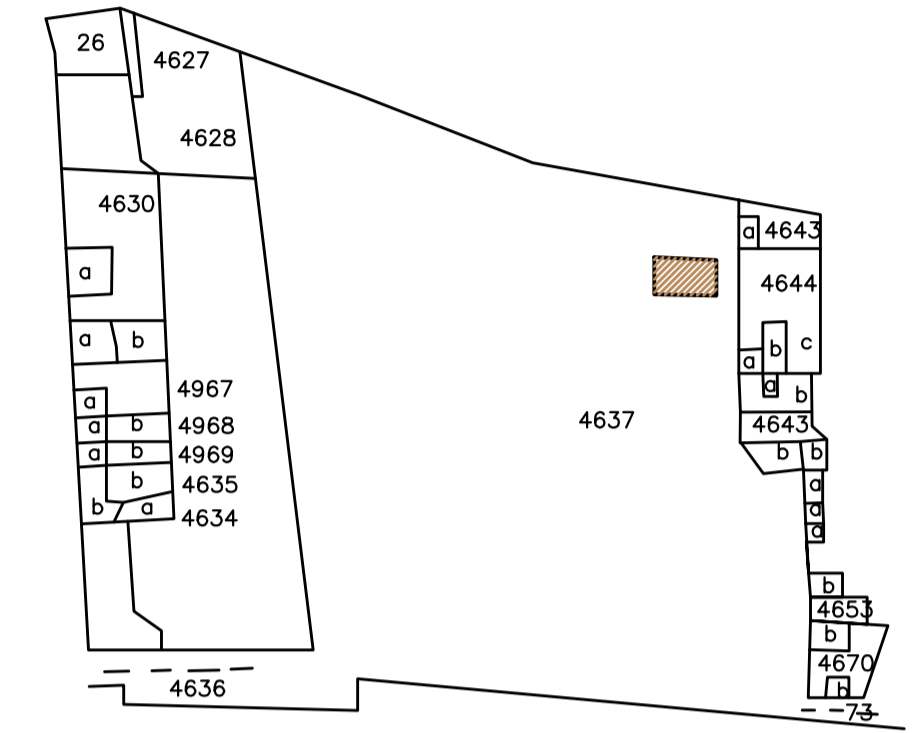

MOUZA PLAN (NTS)

GROUND FLOOR PLAN (Proposed) (SCALE 1:100)

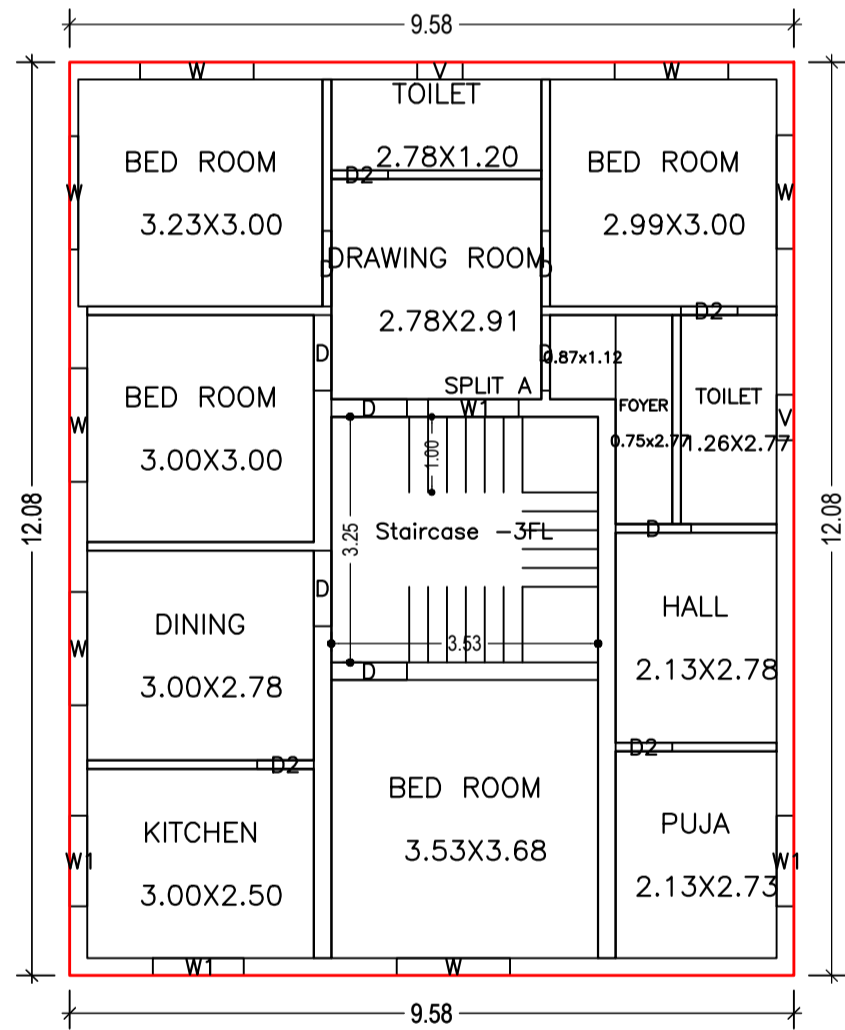

FIRST FLOOR PLAN (Proposed) (SCALE 1:100)

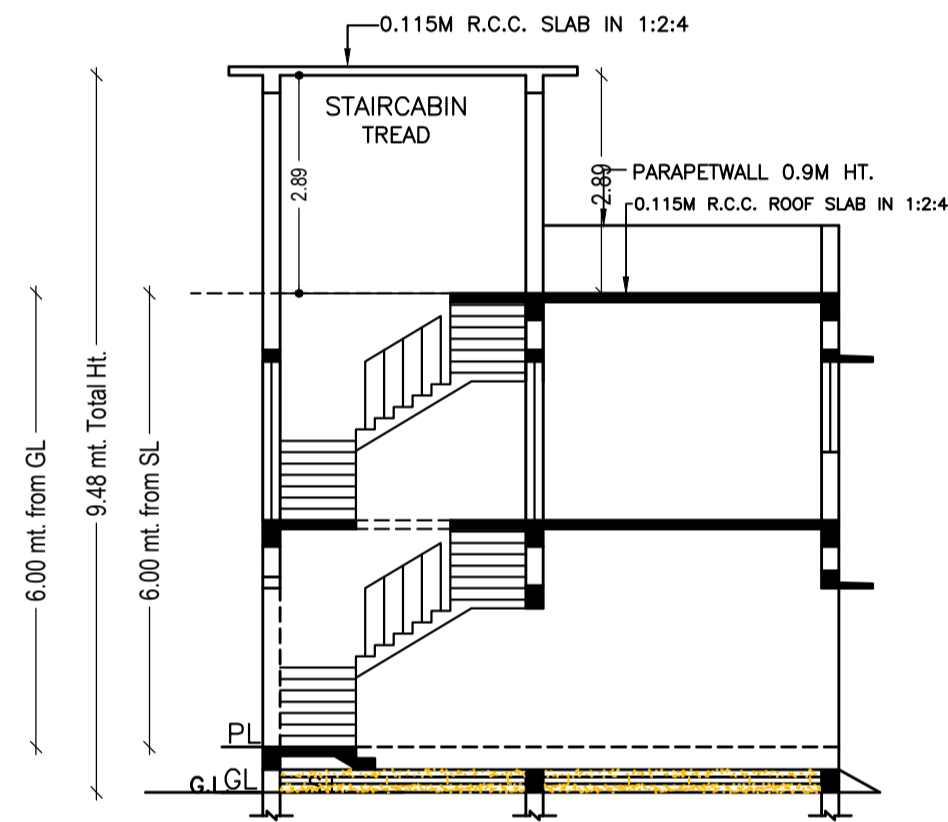
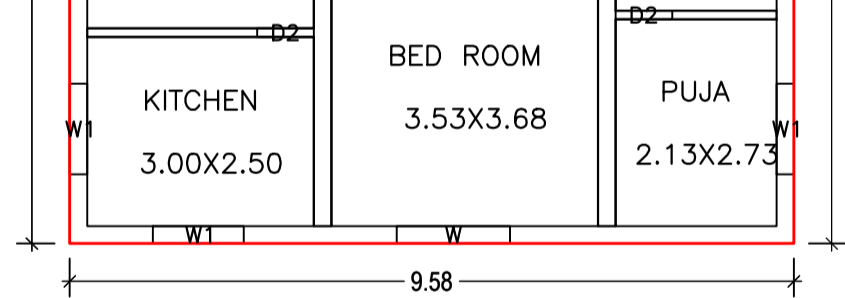

SECTION- AA SCALE 1:100

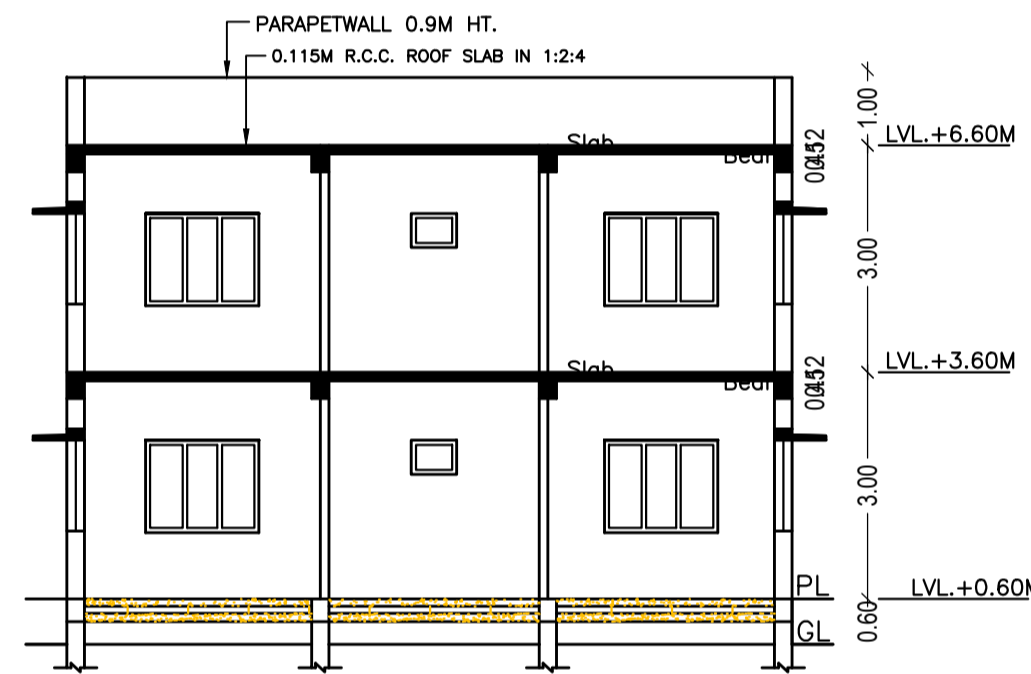

SECTION- BB SCALE 1:100

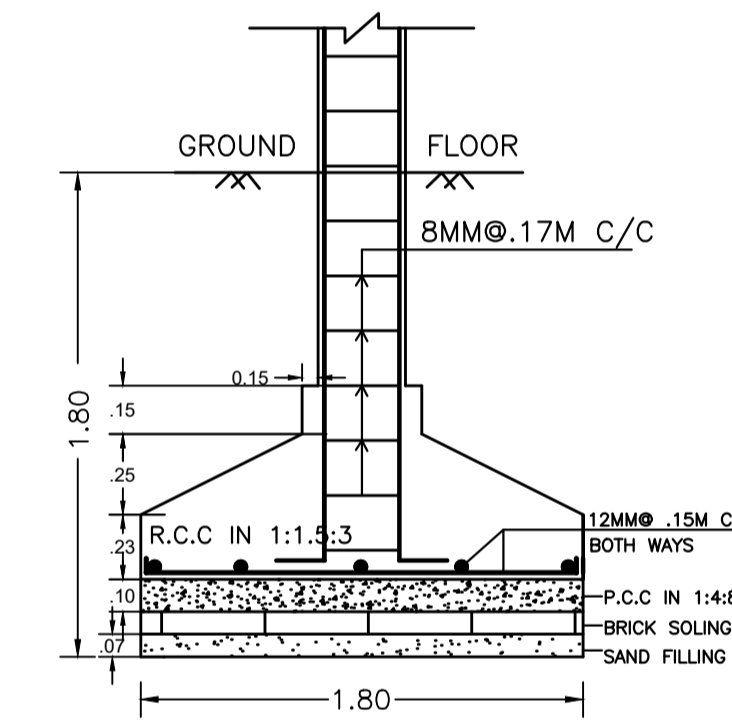

SECTION - CC SCALE -1:25

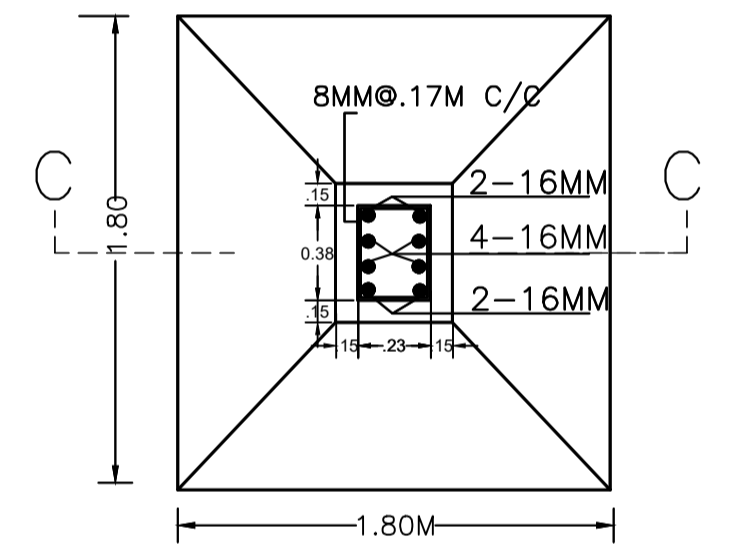

R.C.C. COL. FDN. PLAN SCALE -1:25

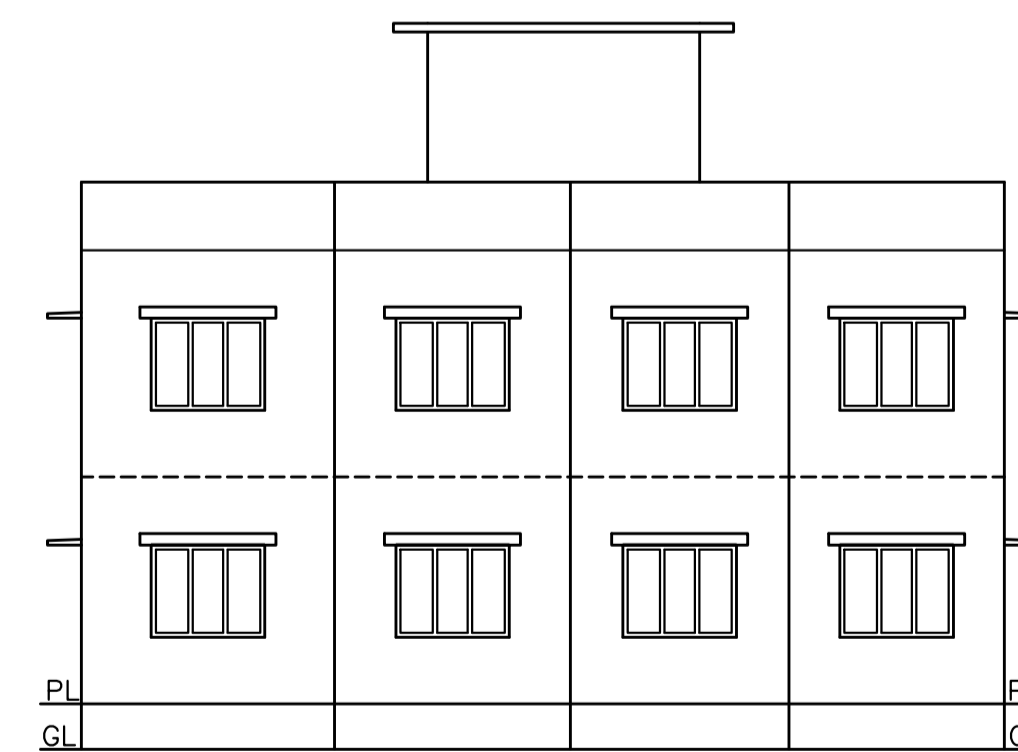

SOUTH SIDE ELEVATION SCALE 1:100

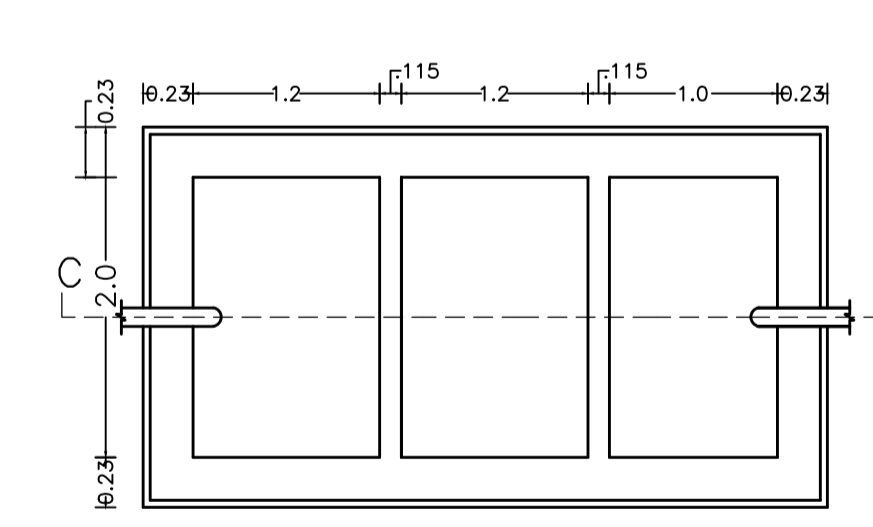

SEPTIC TANK PLAN SCALE -1:50

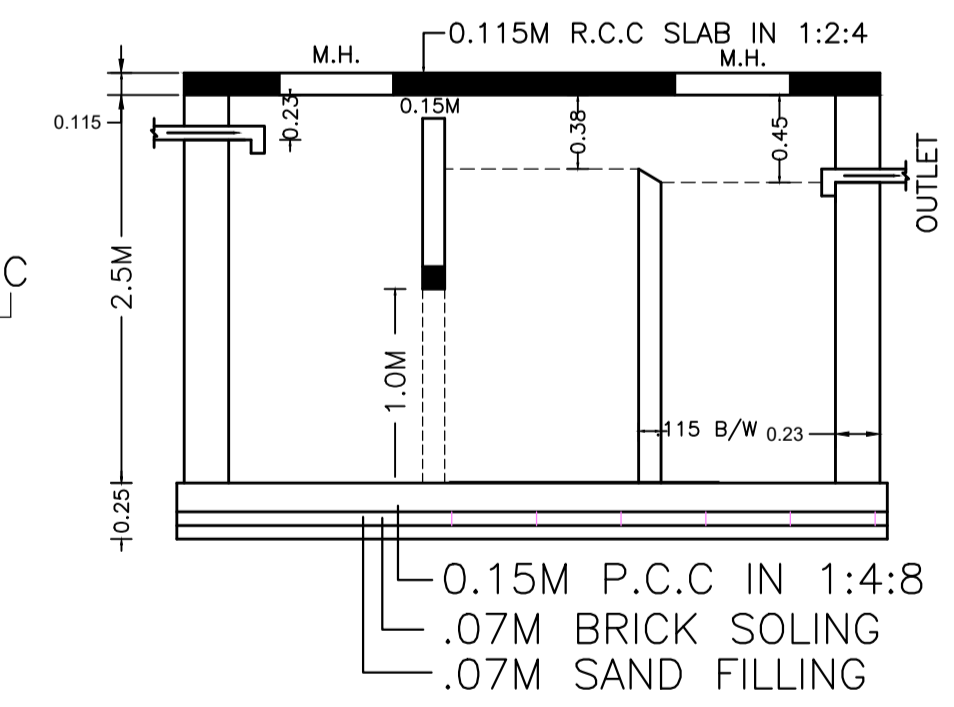

SECTION - SS SCALE -1:50

Building :A (RESIDENTIAL)

Floor Name	Total Built Up Area (Sq.mt.)	Deductions (Area in Sq.mt.)	Proposed FAR Area (Sq.mt.)	Total FAR Area (Sq.mt.)	Total Consumed Additional FAR Area (Sq.mt.)	Trmt (No.)
Ground Floor	115.72	13.80	101.92	101.92	101.92	01
First Floor	115.73	0.00	115.73	115.73	115.73	00
Terrace Floor	0.00	0.00	0.00	0.00	0.00	00
Total:	231.45	13.80	217.65	217.65	217.65	01
Total Number of Same Buildings	1					
Total:	231.45	13.80	217.65	217.65	217.65	01

SCHEDULE OF DOOR:

BUILDING NAME	NAME	LENGTH	HEIGHT	NOS
A (RESIDENTIAL)	D2	0.75	2.10	08
A (RESIDENTIAL)	D	1.00	2.10	15

SCHEDULE OF WINDOW/VENTILATION:

BUILDING NAME	NAME	LENGTH	HEIGHT	NOS
A (RESIDENTIAL)	V	0.60	0.90	04
A (RESIDENTIAL)	W1	1.20	1.20	08
A (RESIDENTIAL)	W	1.50	1.20	13

UnitBUA Table for Building :A (RESIDENTIAL)

FLOOR	Name	UnitBUA Type	UnitBUA Area	Carpet Area	No. of Rooms	No. of Tenement
GROUND FLOOR PLAN	SPLIT A	FLAT	187.36	171.70	11	1
FIRST FLOOR PLAN	SPLIT A	FLAT	0.00	0.00	12	0
Total:	-	-	187.36	171.70	23	1

LTP NAME AND SIGNATURE	STRUCTURAL ENG'S NAME AND SIGNATURE	BUILDER NAME AND SIGNATURE	DIGITAL SIGNATURE
EJAZ AHMAD MNAC/DFTMN/0008/2020			