

SITE PLAN  
SCALE 1:100

FAR & Tenement Details (Table 4c-1)

Building	No. of Same Bldg	Total Built Up Area (Sq.mt)	Deductions	Proposed FAR Area (Sq.mt)	Add Area In FAR (Sq.mt)	Total FAR Area (Sq.mt)	Total Consumed Additional FAR Area (Sq.mt)	Tenmt (No.)
			(Area in Sq.mt)					
A (RESIDENTIAL)	1	269.76	77.83	183.18	8.75	191.93	191.93	01
Grand Total :	1	269.76	77.83	183.18	8.75	191.93	191.93	01

Proposal Basic Information

Proposal File No.	MNAC/BP/0056/W09/2023
Owner Name	MR. YASH JAISWAL
Khata No	481
Plot No	461
Village Name	Pardih
Use	Residential
SubUse	Bungalow/ Dwelling / Non Apartment

AREA STATEMENT MANGO MUNICIPAL CORPORATION		VERSION NO. : 1.0.66
		VERSION DATE: 16/10/2020
PROJECT DETAIL:		
Region: JHARKHAND URBAN LOCAL BODIES	Plot Use: Residential	
District: EAST SINGHBHUM	Plot SubUse: Bungalow/ Dwelling / Non Apartment	
Authority: MANGO MUNICIPAL CORPORATION	PlotNearbyReligiousStructure: NA	
Inward No: MNAC/BP/0056/W09/2023	PlotSubPlot No: 461	
Application Type: General Proposal	North: Road Width - 4.90	
Project Type: Building Permission	South: Plot No. - 461	
Nature of Development: New	East: Plot No. - 461	
Location of Development Area: Old Area	West: Road Width - 4.90	
AREA DETAILS:		
AREA OF PLOT (Minimum)	(A)	SQ.MT. 167.13
Deduction for NetPlot Area		
Surrender Free of Cost		1.13
Total		1.13
NET AREA OF PLOT(Gross Plot Area - Deduction from Gross Plot area)	(A-Deductions)	165.99
Deduction for Balance Plot Area(from Gross Plot Area)		
Surrender Free of Cost		1.13
Common Plot		19.45
Total		20.59
BALANCE AREA OF PLOT(Net Plot Area - Recreational/Amenity space)	(A-Deductions)	146.54
PLOT AREA FOR COVERAGE(Net Plot Area)	(A-Deductions)	165.99
Plot Area for FAR (Net Plot Area + Road Widening Area)	(A-Deductions)	167.13
COVERAGE CHECK		
Permissible Coverage area ( 70.00 % )		116.19
Proposed Coverage Area ( 54.17 % )		89.92
Total Prop. Coverage Area ( 54.17 % )		89.92
Balance coverage area ( 15.83 % )		26.27
FAR CHECK		
Perm. FAR Area ( 1.800 )		300.83
Total Perm. FAR area		300.83
Residential FAR		183.18
Proposed FAR Area		191.93
Total Proposed FAR Area		191.93
Consumed FAR (Factor)		1.15
Balance FAR Area		108.90
BUILT UP AREA CHECK		
Total Proposed BuiltUp Area		269.76
ARCHITECT (Regd)	Chandrika Sharma	
ENGINEER (Regd)		
SUPERVISOR (Regd)		
OWNER (Regd)	MR. YASH JAISWAL	
DEVELOPMENT AUTHORITY		LOCAL BODY

COLOR INDEX	
PLOT BOUNDARY	Black
ABUTTING ROAD	Green
PROPOSED CONSTRUCTION	Red
COMMON PLOT	Yellow
ROAD WIDENING AREA	Orange
EXISTING (To be retained)	Blue
EXISTING (To be demolished)	Light Blue

Buildingwise Floor FAR Details

Floor Name	Building Name A (RESIDENTIAL)		Total	
	Proposed Built Up Area (Sq.mt.)	Proposed FAR Area (Sq.mt.)	Total Proposed Built Up Area (Sq.mt.)	Total FAR Area (Sq.mt.)
Ground Floor	89.92	12.09	89.92	12.09
First Floor	89.92	89.92	89.92	89.92
Second Floor	89.92	89.92	89.92	89.92
Terrace Floor	0.00	0.00	0.00	0.00
Total :	269.76	191.93	269.76	191.93

Building USE/SUBUSE Details

Building Name	Building Use	Building SubUse	Building Structure
A (RESIDENTIAL)	Residential	Bungalow/ Dwelling / Non Apartment	Non-Highrise

LTP NAME AND SIGNATURE	STRUCTURAL ENG'S NAME AND SIGNATURE	BUILDER NAME AND SIGNATURE	DIGITAL SIGNATURE
Chandrika Sharma MNAC/DFTMN/0017/2017			

Proposal Basic Information	
Proposal File No.	MNAC/BP/0056/W09/2023
Owner Name	MR. YASH JAISWAL
Khata No	481
Plot No	461
Village Name	Pardih
Use	Residential
SubUse	Bungalow/ Dwelling / Non Apartment

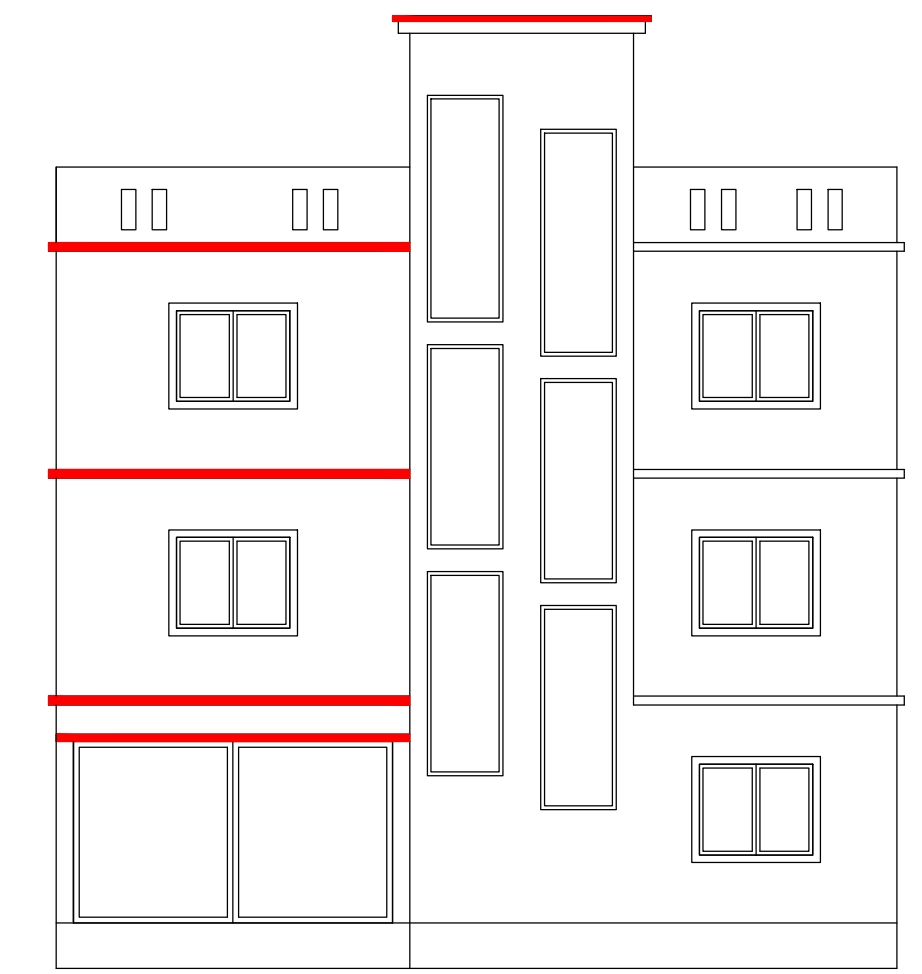
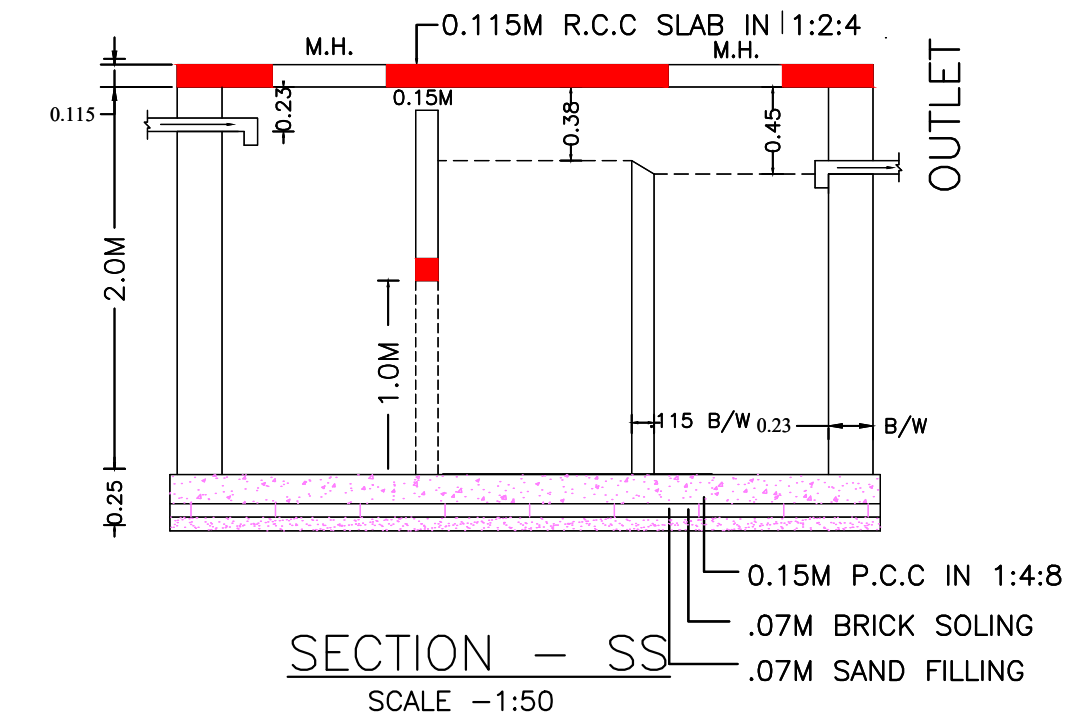
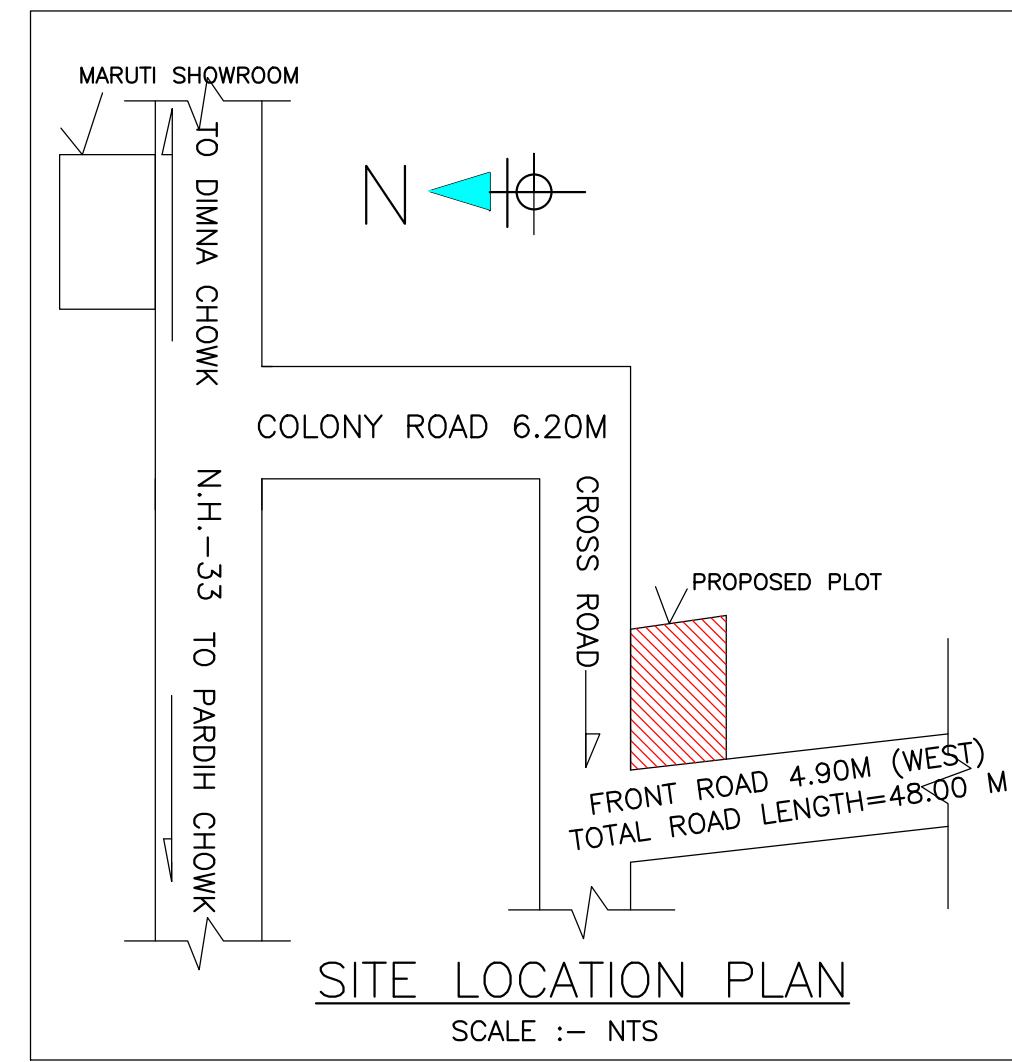
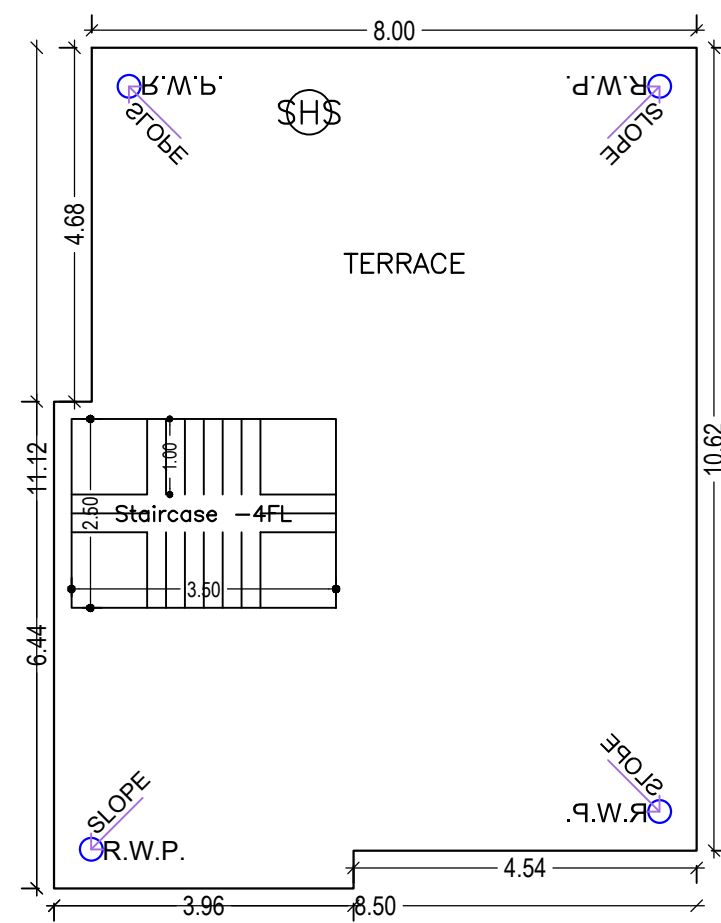
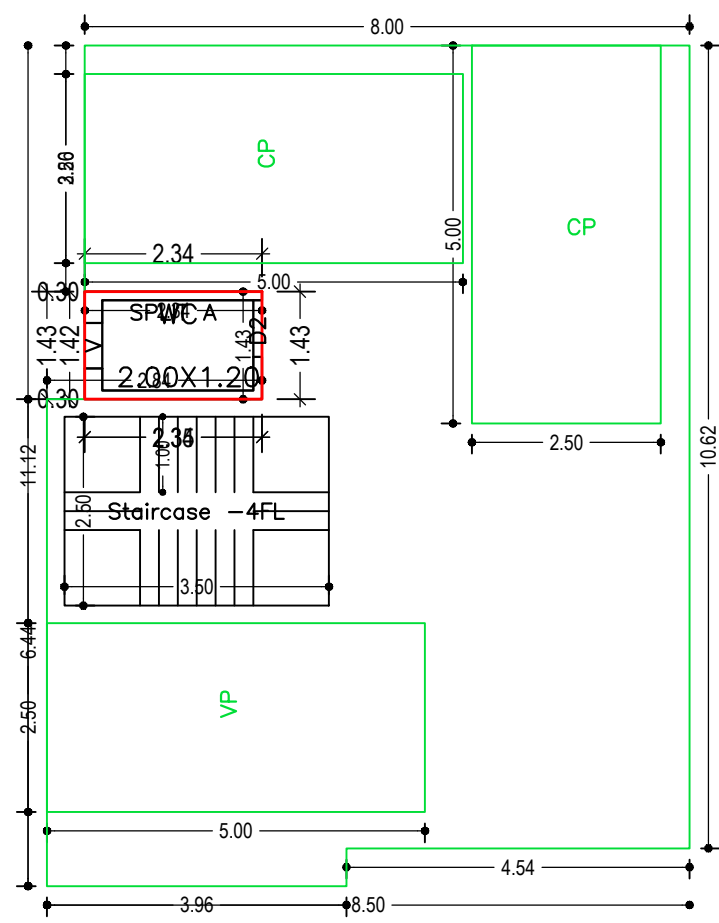

GROUND FLOOR PLAN (Proposed) (SCALE 1:100)

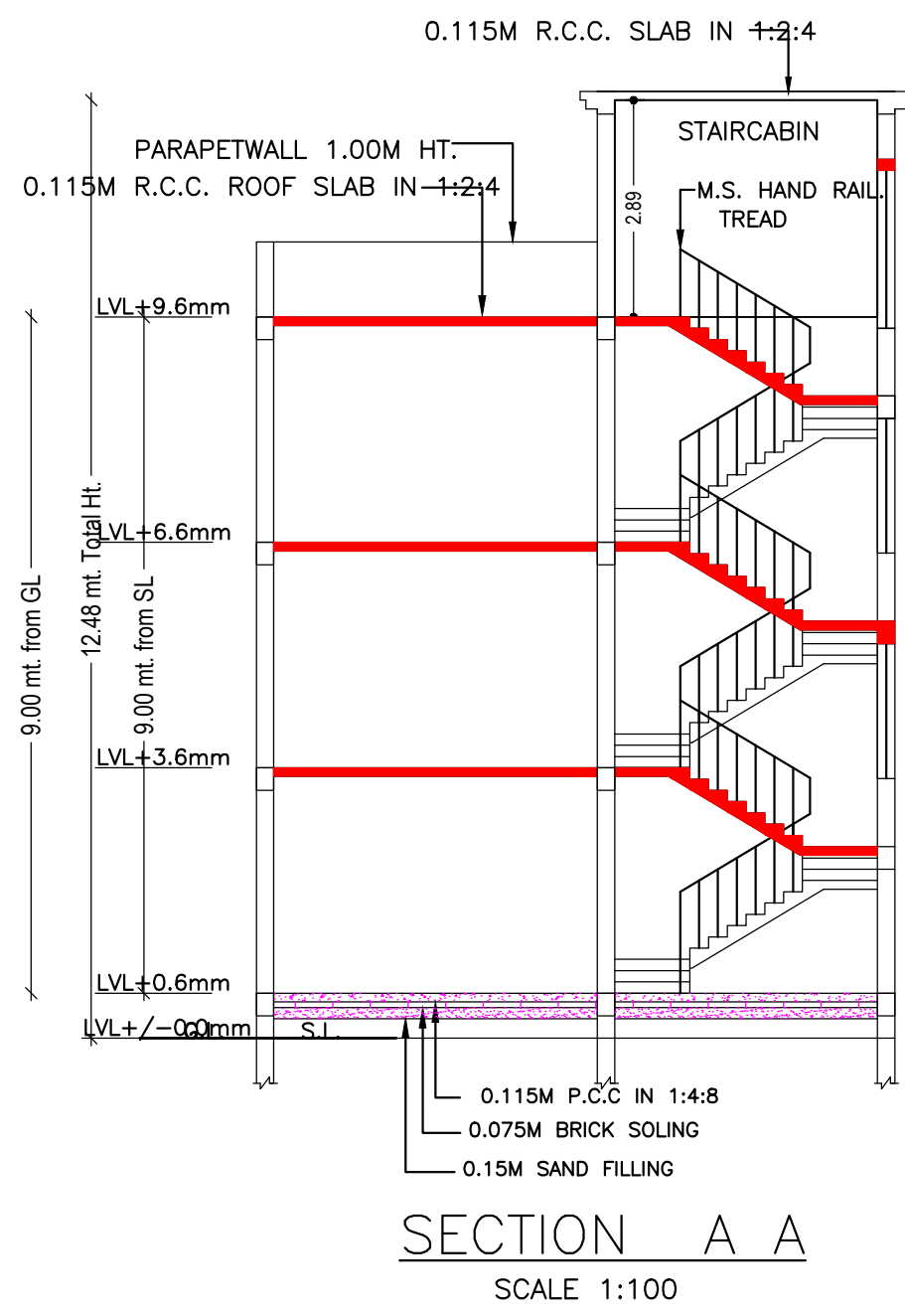
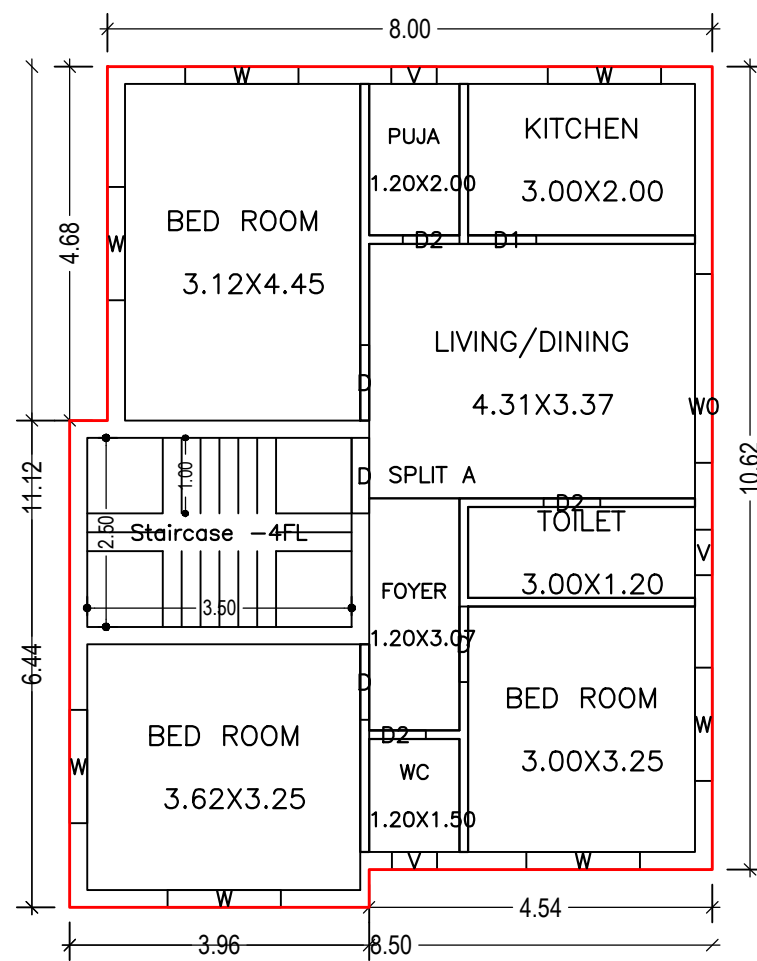

SEPTIC TANK PLAN

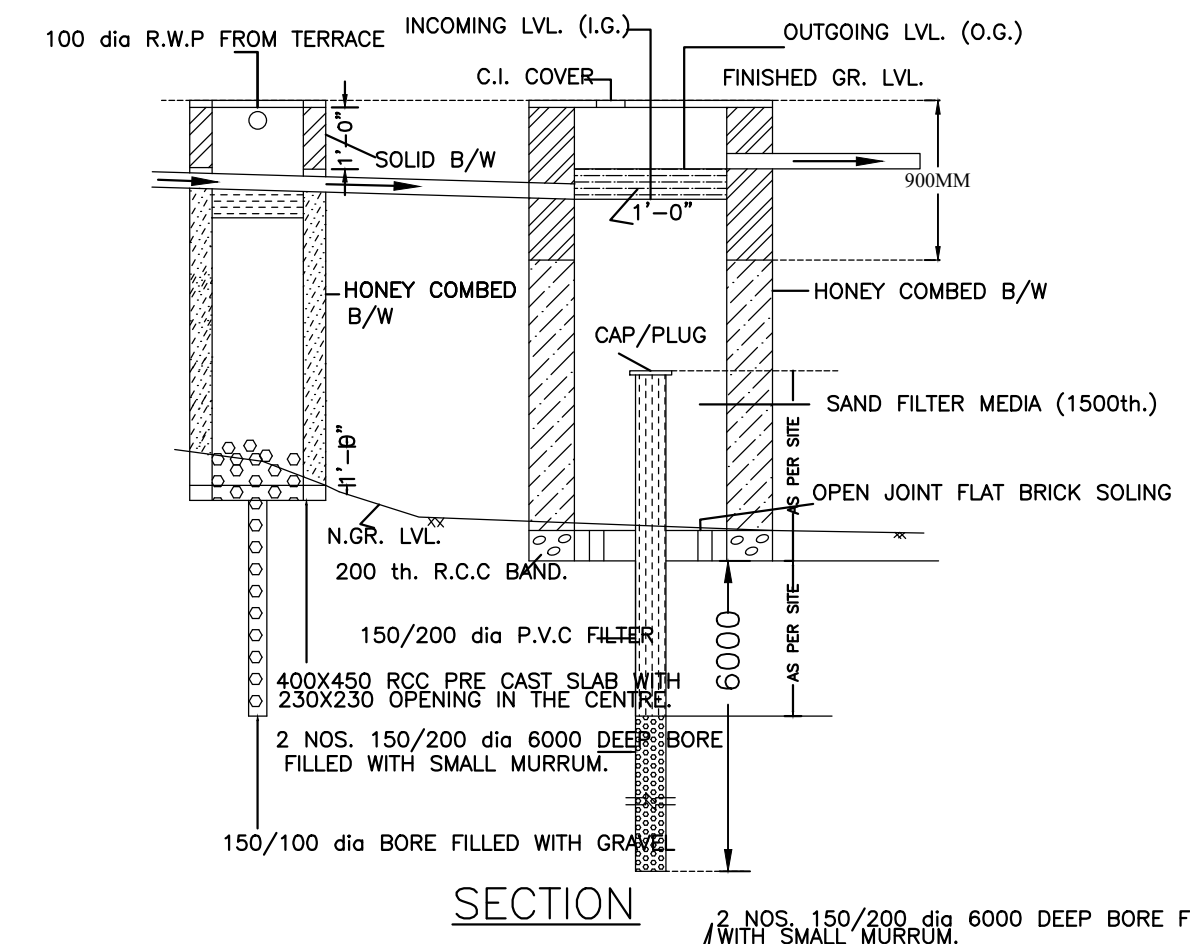

NORTH SIDE ELEVATION (SCALE 1:100)

TYPICAL - 1& 2 FLOOR PLAN (Proposed) (SCALE 1:100)

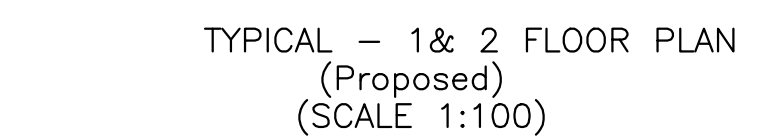

SECTION

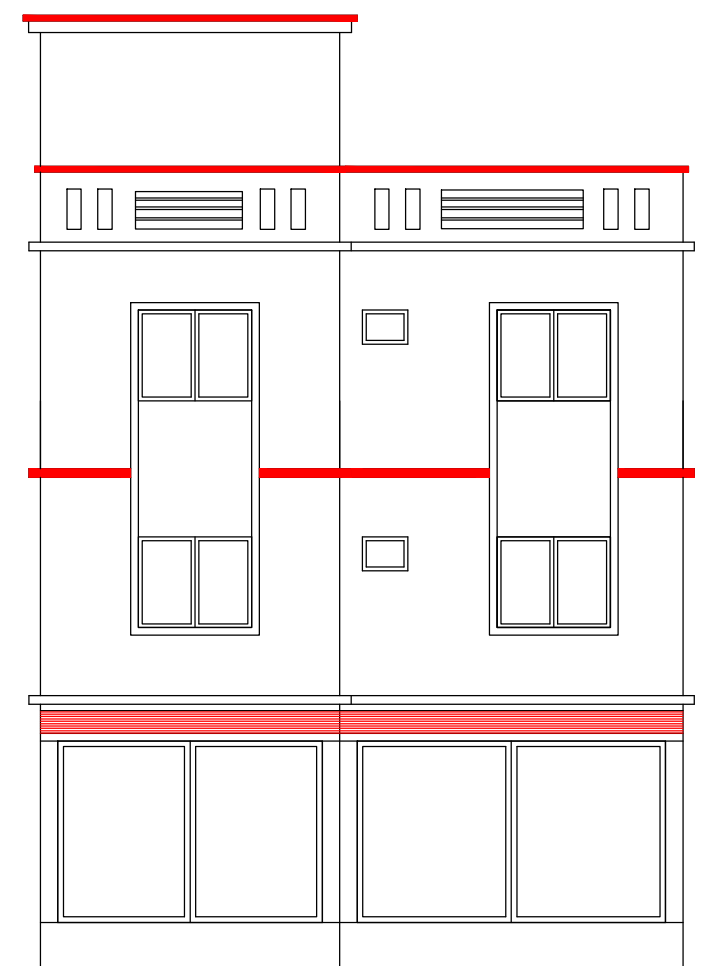
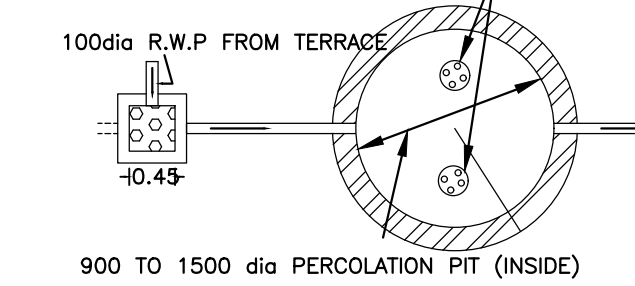

FRONT ELEVATION (SCALE 1:100)

WATER HARVESTING PLAN (NTS)

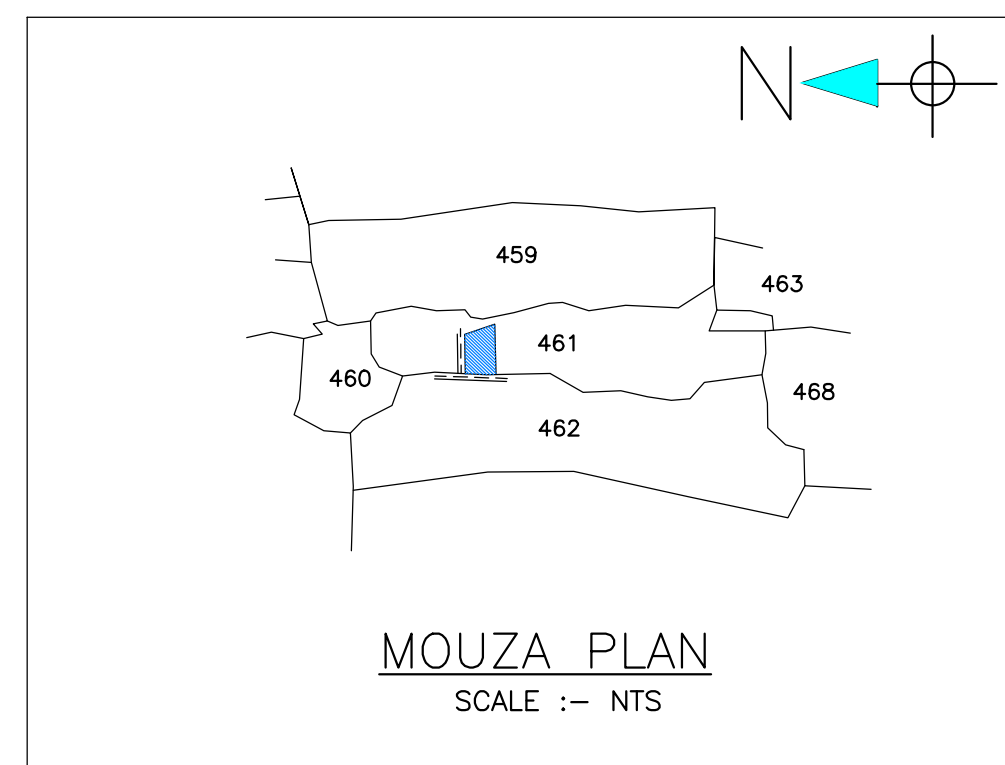

MOUZA PLAN (SCALE :- NTS)

Building :A (RESIDENTIAL)

Floor Name	Total Built Up Area (Sq.mt.)	Deductions (Area in Sq.mt.)			Proposed FAR Area (Sq.mt.)	Add Area In FAR (Sq.mt.)	Total FAR Area (Sq.mt.)	Total Consumed Additional FAR Area (Sq.mt.)	Trmt (No.)
		Parking	Resi.	Stair					
Ground Floor	89.92	77.83	3.34	8.75	12.09	12.09	01		
First Floor	89.92	0.00	89.92	0.00	89.92	89.92	00		
Second Floor	89.92	0.00	89.92	0.00	89.92	89.92	00		
Terrace Floor	0.00	0.00	0.00	0.00	0.00	0.00	00		
Total :	269.76	77.83	183.18	8.75	191.93	191.93	01		
Total Number of Same Buildings	1								
Total :	269.76	77.83	183.18	8.75	191.93	191.93	01		

SCHEDULE OF DOOR:

BUILDING NAME	NAME	LENGTH	HEIGHT	NOS
A (RESIDENTIAL)	D2	0.75	2.10	07
A (RESIDENTIAL)	D1	0.90	2.10	02
A (RESIDENTIAL)	D	1.00	2.10	08

SCHEDULE OF WINDOW/VENTILATION:

BUILDING NAME	NAME	LENGTH	HEIGHT	NOS
A (RESIDENTIAL)	V	0.60	0.90	07
A (RESIDENTIAL)	W	1.50	1.20	14
A (RESIDENTIAL)	W0	2.50	1.20	02

UnitBUA Table for Building :A (RESIDENTIAL)

FLOOR	Name	UnitBUA Type	UnitBUA Area	Carpet Area	No. of Rooms	No. of Tenement
GROUND FLOOR PLAN	SPLIT A	FLAT	143.82	137.25	1	1
TYPICAL - 1& 2 FLOOR PLAN	SPLIT A	FLAT	0.00	0.00	9	0
Total:	-	-	143.82	137.25	19	1

LTP NAME AND SIGNATURE	STRUCTURAL ENG'S NAME AND SIGNATURE	BUILDER NAME AND SIGNATURE	DIGITAL SIGNATURE
Chandrika Sharma MNAC/DFTMN/0017/2017			

Proposal Basic Information

Proposal File No.	MNAC/BP/0056/W09/2023
Owner Name	MR. YASH JAISWAL
Khata No	481
Plot No	461
Village Name	Pardih
Use	Residential
SubUse	Bungalow/ Dwelling / Non Apartment

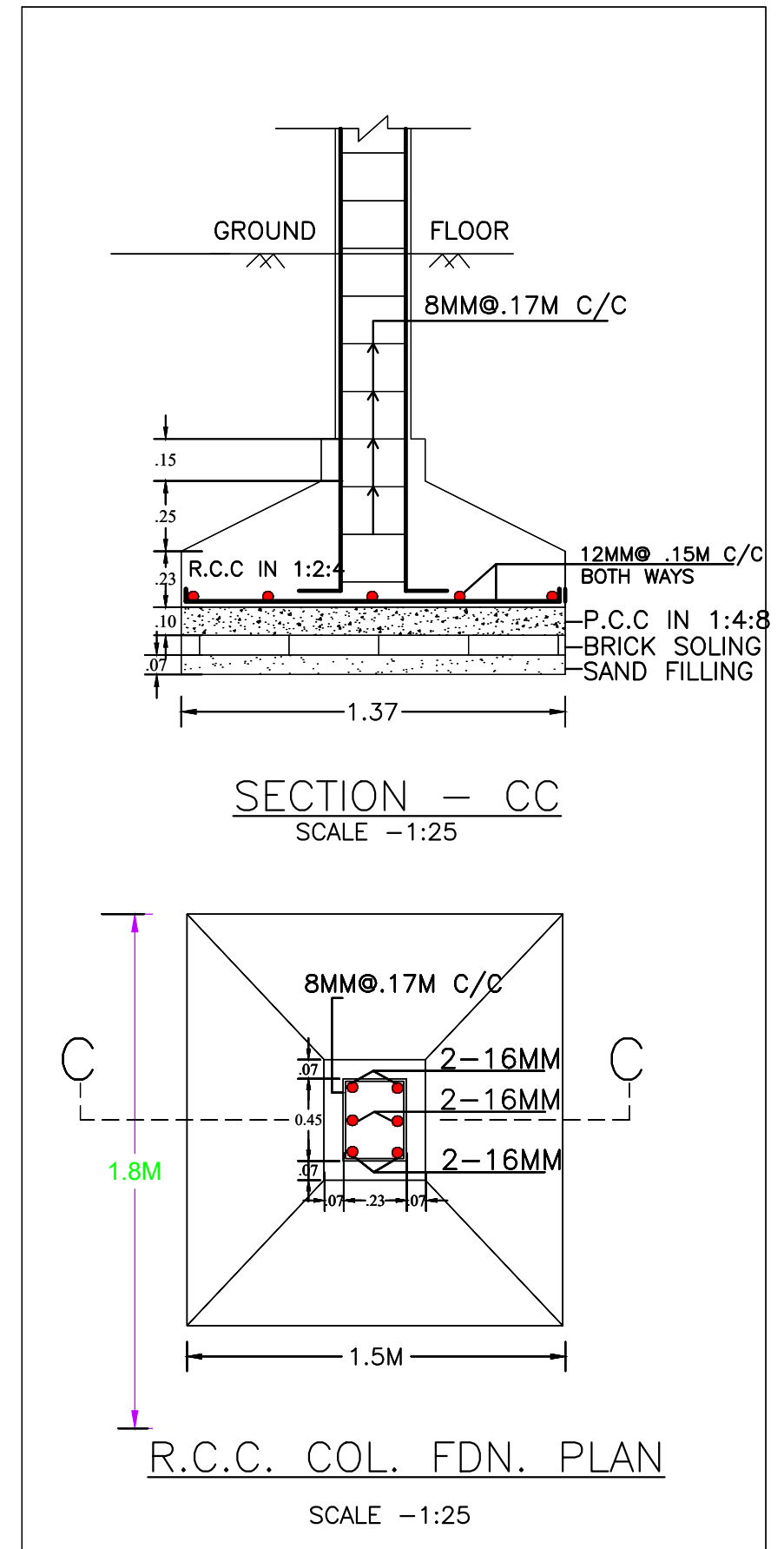

LTP NAME AND SIGNATURE	STRUCTURAL ENG'S NAME AND SIGNATURE	BUILDER NAME AND SIGNATURE	DIGITAL SIGNATURE
Chandrika Sharma MNAC/DFTMN/0017/2017			