

SITE - PLAN
SCALE 1:100

SITE PLAN

FAR & Tenement Details (Table 4c-1)

Building	No. of Same Bldg	Total Built Up Area (Sq.mt.)	Deductions (Area in Sq.mt.)		Proposed FAR Area (Sq.mt.)	Total FAR Area (Sq.mt.)	Total Consumed Additional FAR Area (Sq.mt.)	Trnmt (No.)
			Parking	Resi.				
A (RESIDENTIAL)	1	258.75	33.57		225.18	225.18	225.18	01
Grand Total :	1	258.75	33.57		225.18	225.18	225.18	01

Proposal Basic Information

Proposal File No.	MNAC/FP/0069/W09/2023
Owner Name	ASHISH KUMAR GUPTA
Khata No	138
Plot No	1552
Village Name	Mango
Use	Residential
SubUse	Bungalow/ Dwelling / Non Apartment

AREA STATEMENT MANGO MUNICIPAL CORPORATION		VERSION NO. : 1.0.68
		VERSION DATE: 16/10/2020
PROJECT DETAIL:		
Region: JHARKHAND URBAN LOCAL BODIES	Plot Use: Residential	
District: EAST SINGHBHUM	Plot SubUse: Bungalow/ Dwelling / Non Apartment	
Authority: MANGO MUNICIPAL CORPORATION	PlotNearbyReligiousStructure: NA	
Inward No: MNAC/FP/0069/W09/2023	PlotSubPlot No: 1552	
Application Type: General Proposal	North: -	
Project Type: Building Permission	South: -	
Nature of Development: New	East: -	
Location of Development Area: Old Area	West: -	
AREA DETAILS:		
AREA OF PLOT (Minimum)	(A)	SQ.MT. 133.68
NET AREA OF PLOT(Gross Plot Area - Deduction from Gross Plot area)	(A-Deductions)	133.68
Deduction for Balance Plot Area(from Gross Plot Area)		
Common Plot		10.96
Total		10.96
BALANCE AREA OF PLOT(Net Plot Area - Recreational/Amenity space)	(A-Deductions)	122.71
PLOT AREA FOR COVERAGE(Net Plot Area)	(A-Deductions)	133.68
Plot Area for FAR (Net Plot Area + Road Widening Area)	(A-Deductions)	133.68
COVERAGE CHECK		
Permissible Coverage area (70.00 %)		93.58
Proposed Coverage Area (64.52 %)		86.25
Total Prop. Coverage Area (64.52 %)		86.25
Balance coverage area (5.48 %)		7.33
FAR CHECK		
Perm. FAR Area (2.500)		334.20
Total Perm. FAR area		334.20
Residential FAR		225.17
Proposed FAR Area		225.17
Total Proposed FAR Area		225.17
Consumed FAR (Factor)		1.68
Balance FAR Area		109.03
BUILT UP AREA CHECK		
Total Proposed BuiltUp Area		258.75
ARCHITECT (Regd)	EJAZ AHMAD	
ENGINEER (Regd)		
SUPERVISOR (Regd)		
OWNER (Regd)	ASHISH KUMAR GUPTA	
DEVELOPMENT AUTHORITY		LOCAL BODY

COLOR INDEX	
PLOT BOUNDARY	Black
ABUTTING ROAD	Green
PROPOSED CONSTRUCTION	Red
COMMON PLOT	Yellow
ROAD WIDENING AREA	Orange
EXISTING (To be retained)	Blue
EXISTING (To be demolished)	Light Blue

Buildingwise Floor FAR Details

Floor Name	Building Name A (RESIDENTIAL)		Total	
	Proposed Built Up Area (Sq.mt.)	Proposed FAR Area (Sq.mt.)	Total Proposed Built Up Area (Sq.mt.)	Total FAR Area (Sq.mt.)
Ground Floor	86.25	52.68	86.25	52.68
First Floor	86.25	86.25	86.25	86.25
Second Floor	86.25	86.25	86.25	86.25
Terrace Floor	0.00	0.00	0.00	0.00
Total :	258.75	225.18	258.75	225.18

Building USE/SUBUSE Details

Building Name	Building Use	Building SubUse	Building Structure
A (RESIDENTIAL)	Residential	Bungalow/ Dwelling / Non Apartment	Non-Highrise

LTP NAME AND SIGNATURE	STRUCTURAL ENG'S NAME AND SIGNATURE	BUILDER NAME AND SIGNATURE	DIGITAL SIGNATURE
EJAZ AHMAD MNAC/DFTMN/0008/2020			

Proposal Basic Information	
Proposal File No.	MNAC/PI/0069/W09/2023
Owner Name	ASHISH KUMAR GUPTA
Khata No	138
Plot No	1552
Village Name	Mango
Use	Residential
SubUse	Bungalow/ Dwelling / Non Apartment

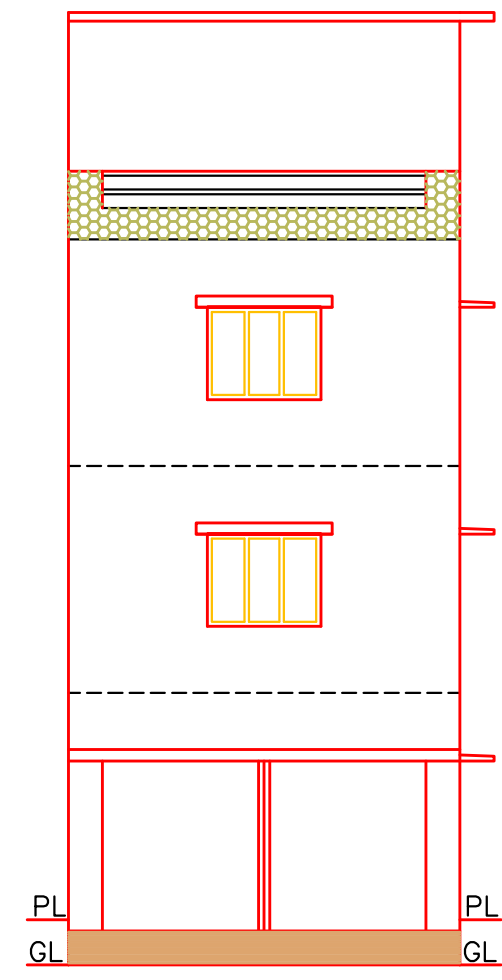
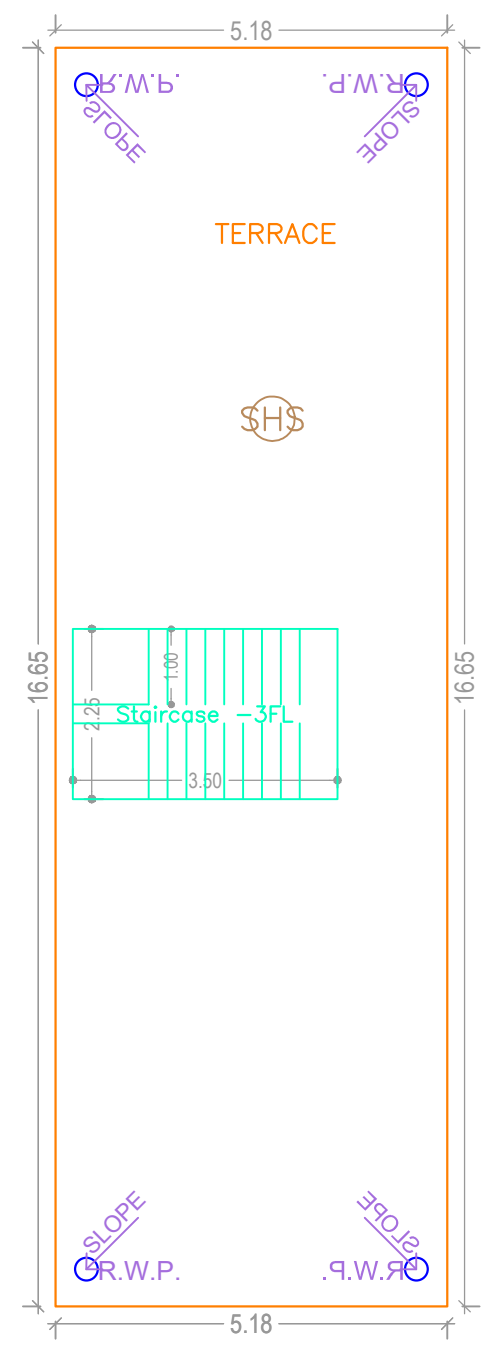
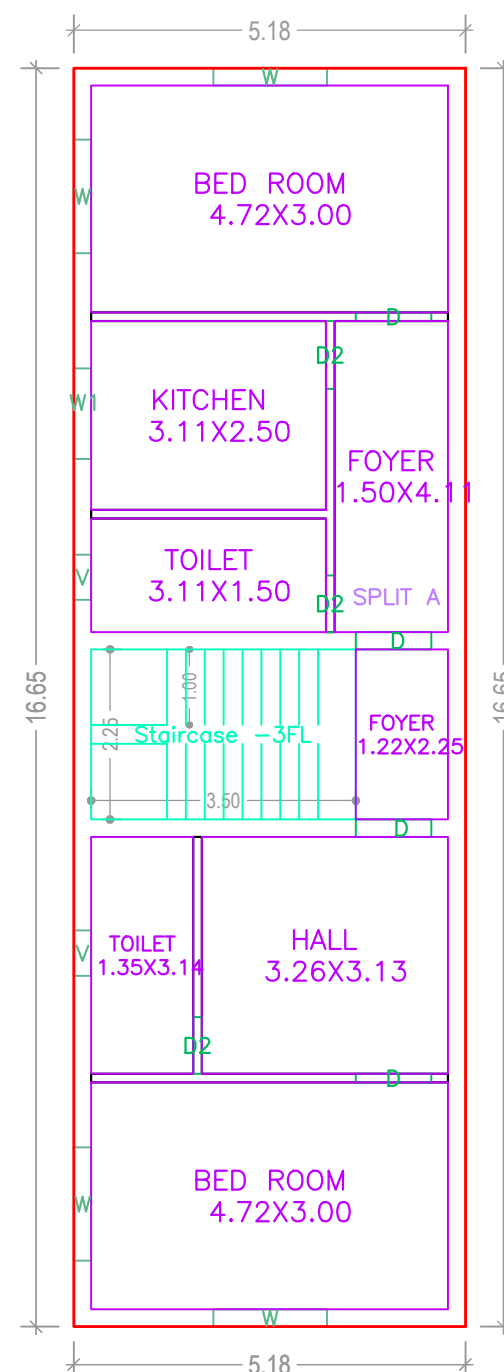
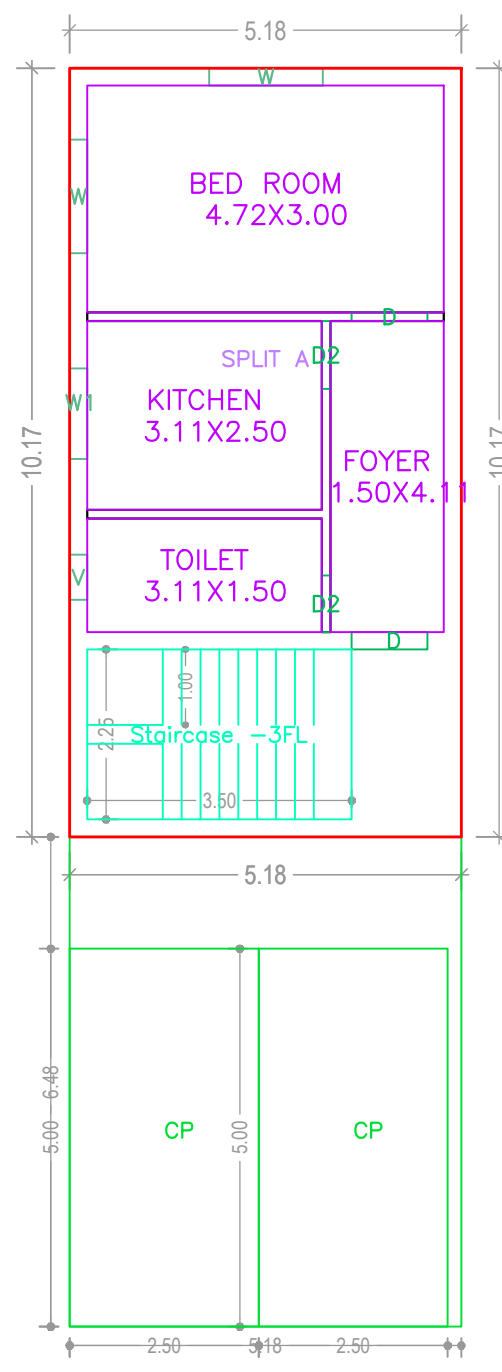

FRONT ELEVATION
SCALE 1:100

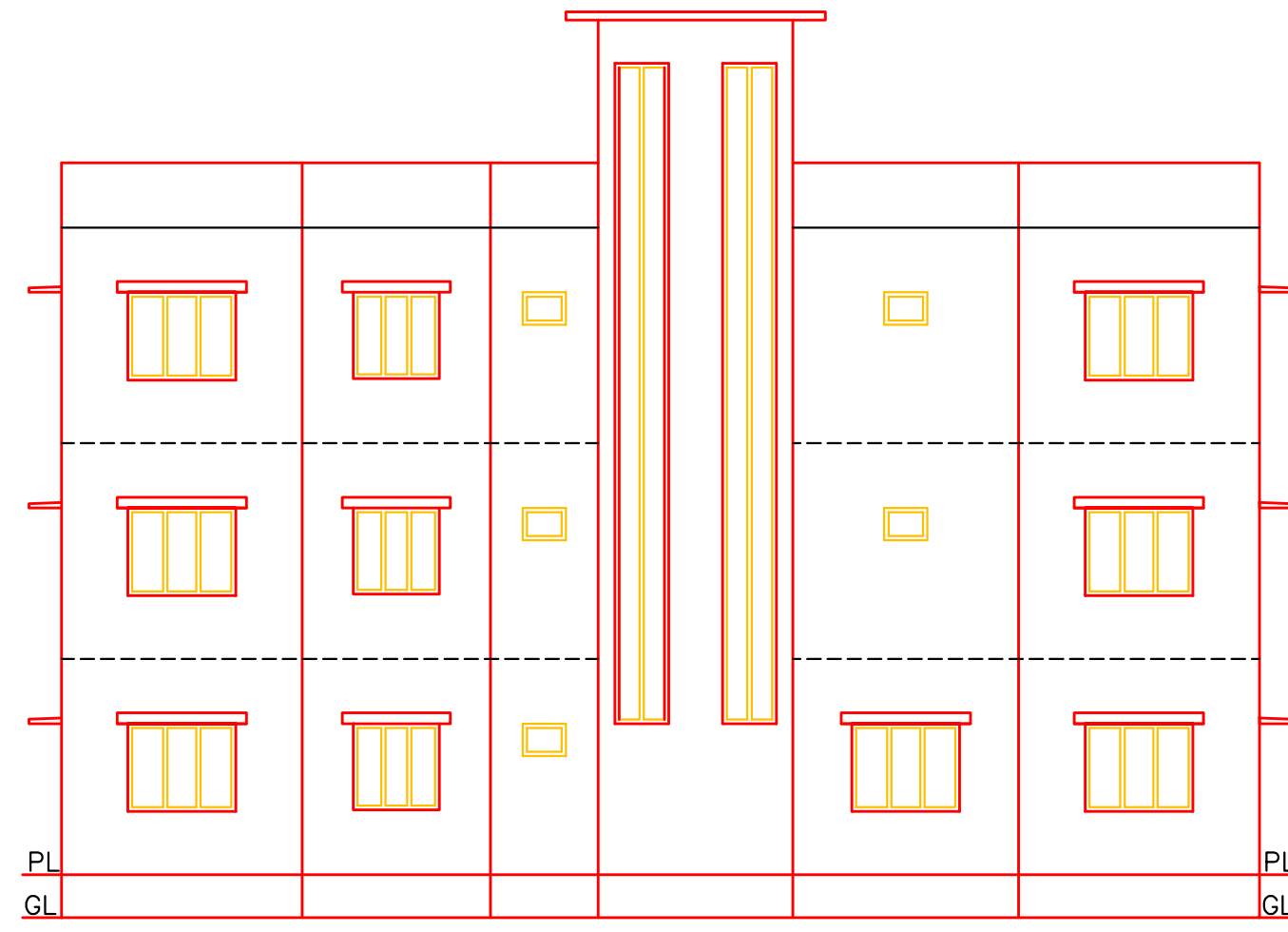

EAST SIDE ELEVATION
SCALE 1:100

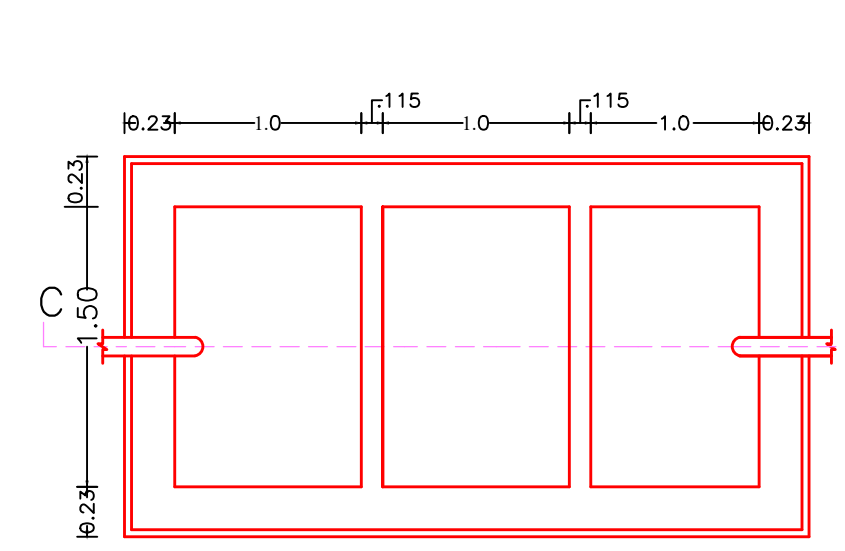

SEPTIC TANK PLAN
SCALE -1:50

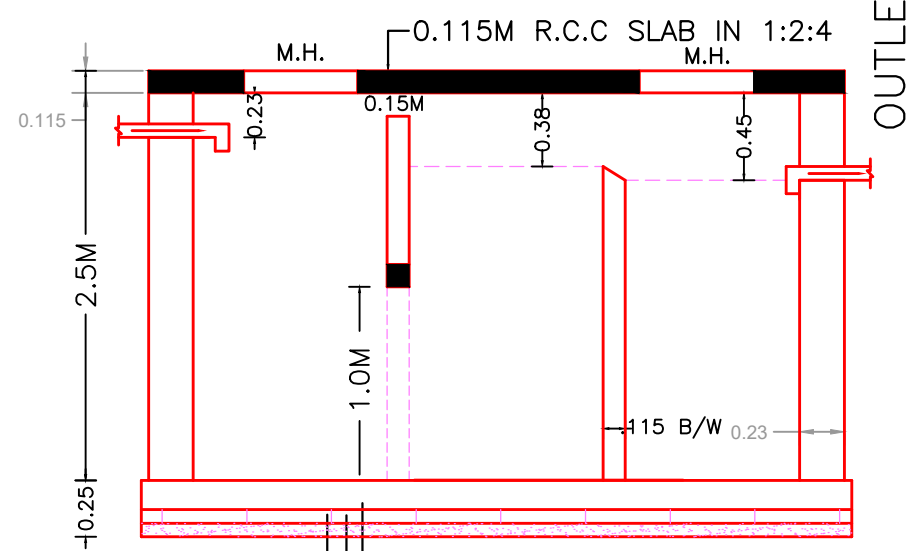

SECTION - SS
SCALE -1:50

TYPICAL - 1 & 2 FLOOR PLAN
(Proposed)
(SCALE 1:100)

TERRACE FLOOR PLAN
(SCALE 1:100)

GROUND FLOOR PLAN
(Proposed)
(SCALE 1:100)

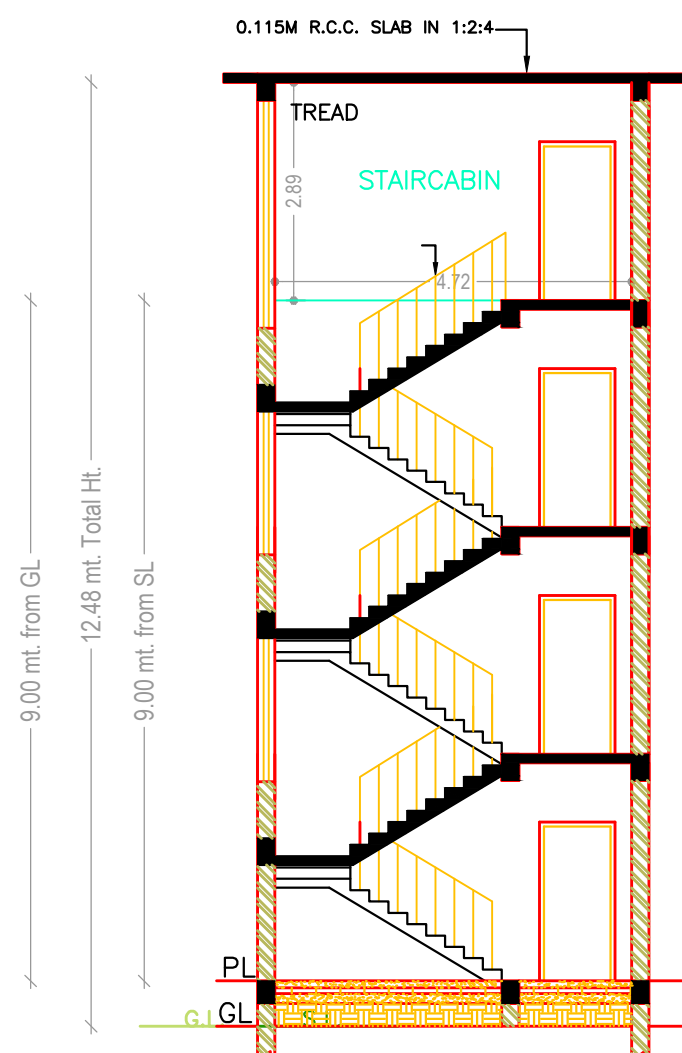

SECTION - AA
SCALE 1:100

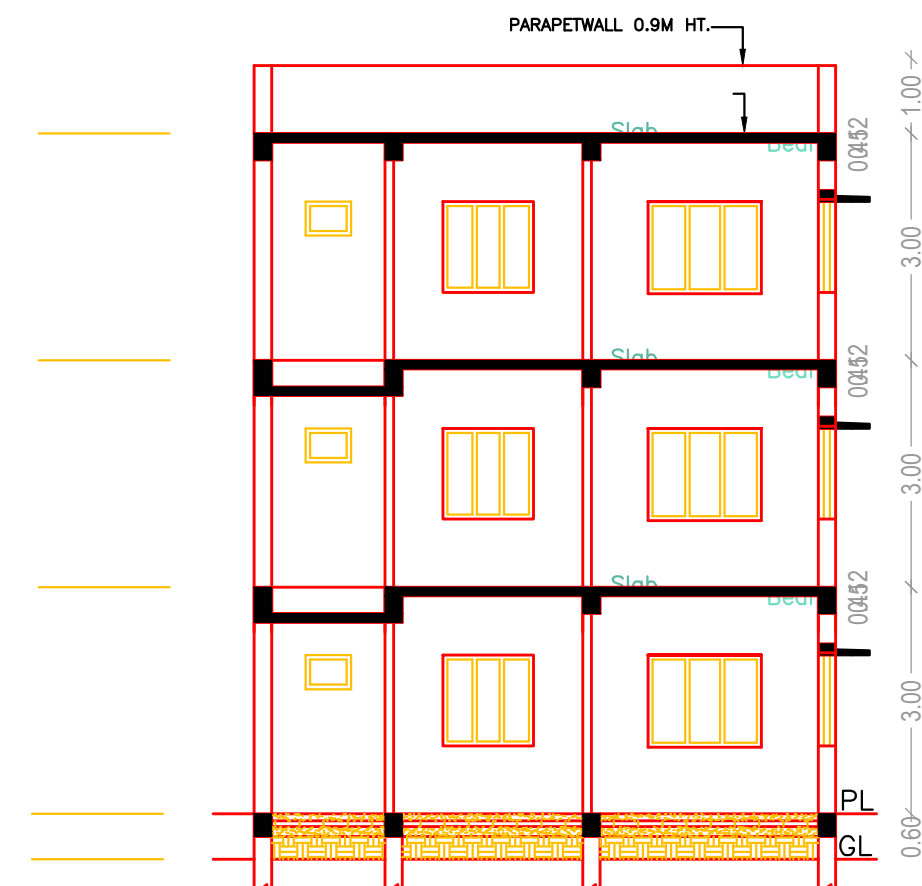

SECTION - BB
SCALE 1:100

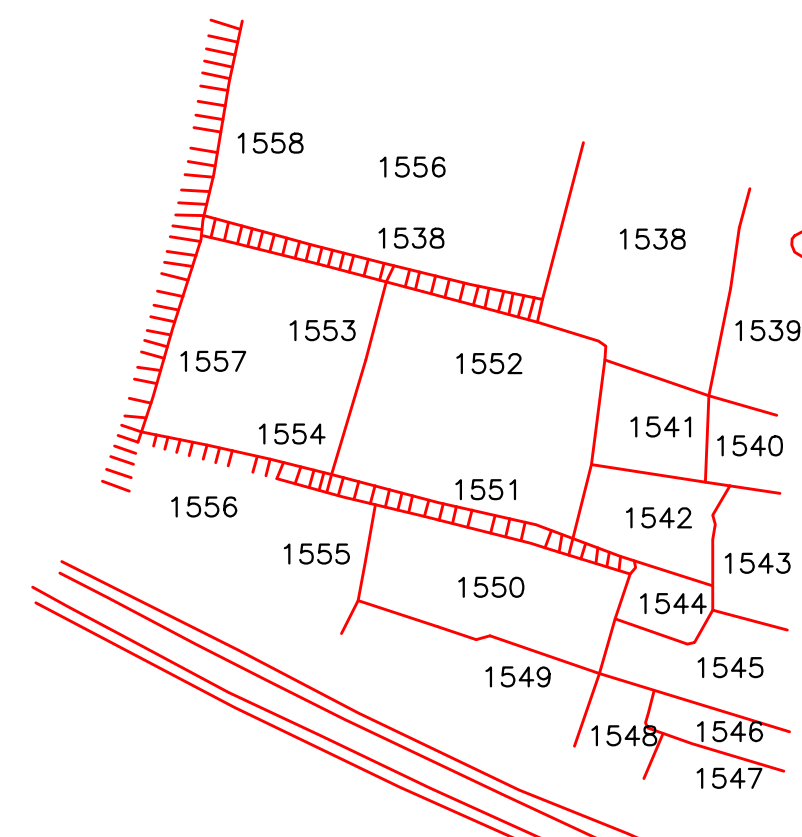

MOUZA PLAN (NTS)

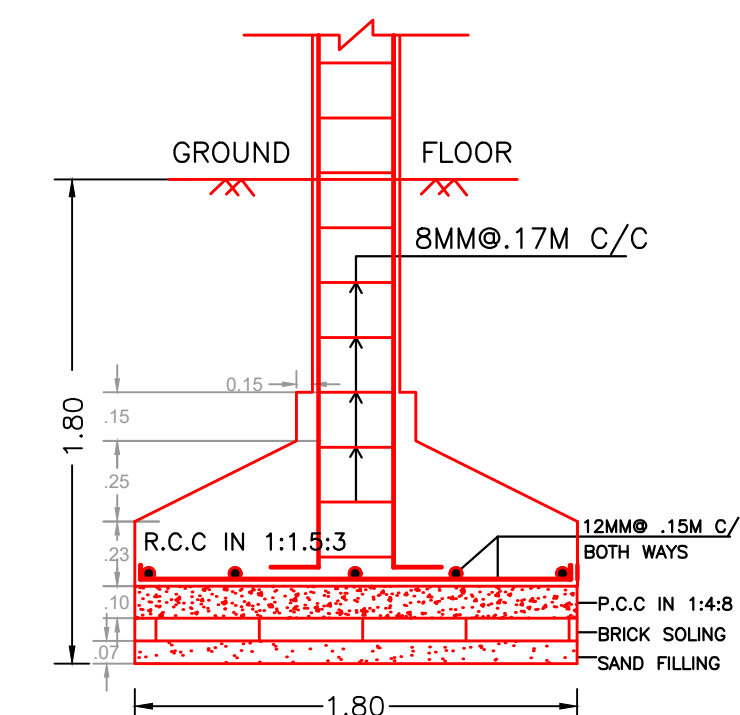

SECTION - CC
SCALE -1:25

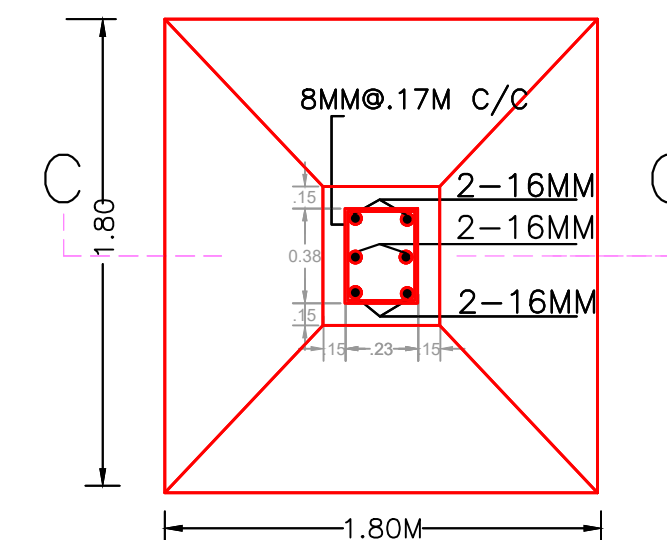

R.C.C. COL. FDN. PLAN
SCALE -1:25

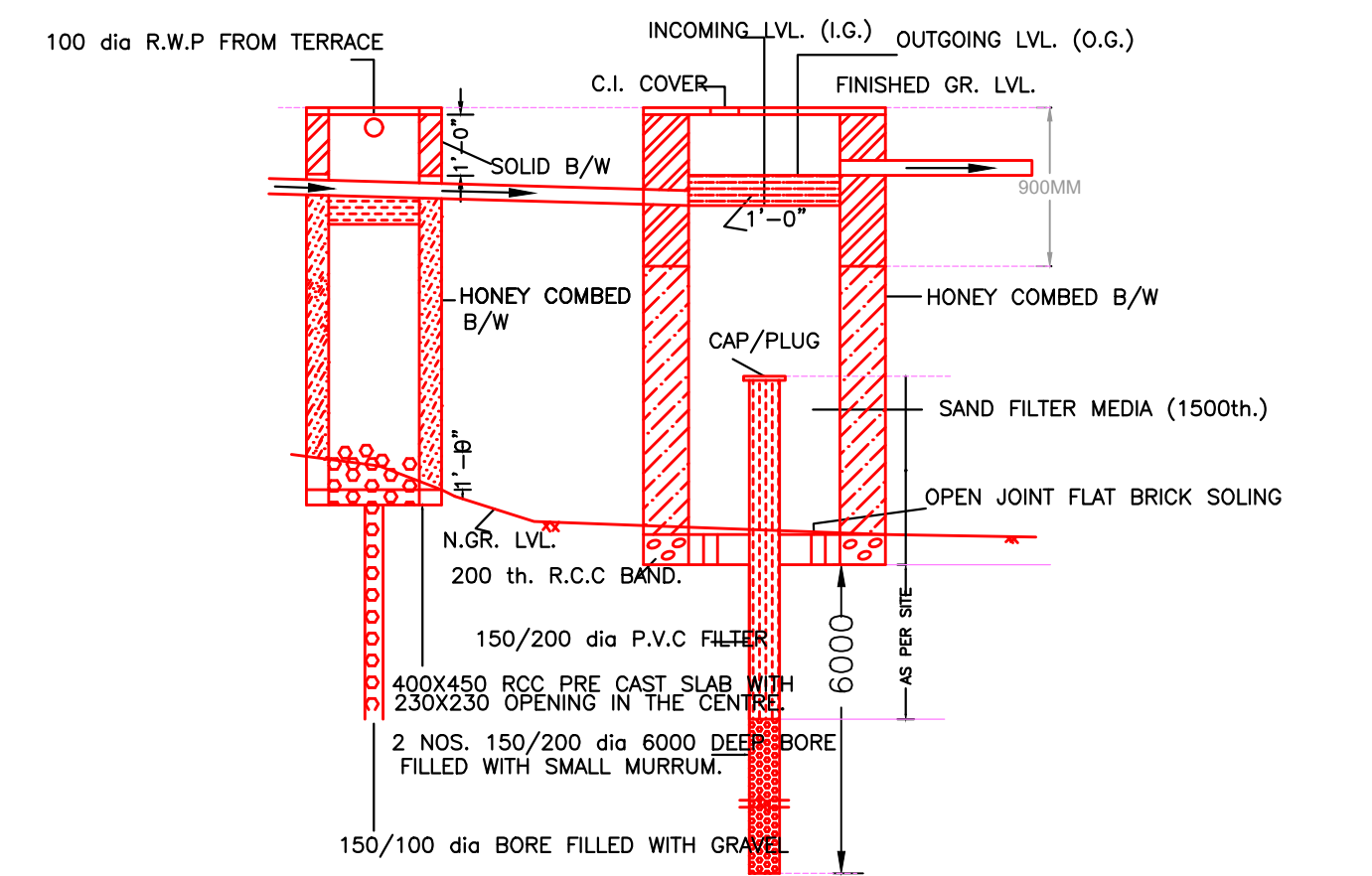

SECTION

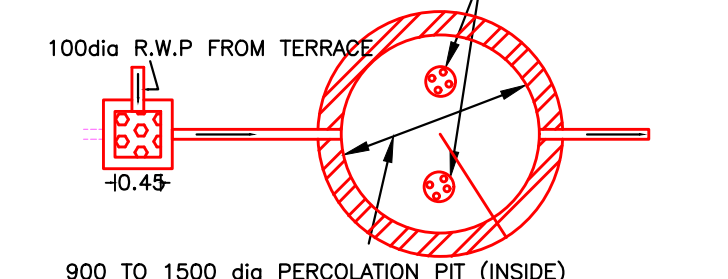

WATER HARVESTING PLAN (NTS)

Building :A (RESIDENTIAL)

Floor Name	Total Built Up Area (Sq.mt.)	Deductions (Area in Sq.mt.)		Proposed FAR Area (Sq.mt.)	Total FAR Area (Sq.mt.)	Total Consumed Additional FAR Area (Sq.mt.)	Trmt (No.)
		Parking	Resi.				
Ground Floor	86.25	33.57	52.68	52.68	52.68	01	
First Floor	86.25	0.00	86.25	86.25	86.25	00	
Second Floor	86.25	0.00	86.25	86.25	86.25	00	
Terrace Floor	0.00	0.00	0.00	0.00	0.00	00	
Total :	258.75	33.57	225.18	225.18	225.18	01	
Total Number of Same Buildings	1						
Total :	258.75	33.57	225.18	225.18	225.18	01	

SCHEDULE OF DOOR:

BUILDING NAME	NAME	LENGTH	HEIGHT	NOS
A (RESIDENTIAL)	D2	0.75	2.10	05
A (RESIDENTIAL)	D2	0.90	2.10	03
A (RESIDENTIAL)	D	1.00	2.10	10

SCHEDULE OF WINDOW/VENTILATION:

BUILDING NAME	NAME	LENGTH	HEIGHT	NOS
A (RESIDENTIAL)	V	0.60	0.90	05
A (RESIDENTIAL)	W1	1.20	1.20	03
A (RESIDENTIAL)	W	1.50	1.20	10

UnitBUA Table for Building :A (RESIDENTIAL)

FLOOR	Name	UnitBUA Type	UnitBUA Area	Carpet Area	No. of Rooms	No. of Tenement
GROUND FLOOR PLAN	SPLIT A	FLAT	167.99	162.06	4	1
TYPICAL - 1 & 2 FLOOR PLAN	SPLIT A	FLAT	0.00	0.00	8	0
Total:	-	-	167.99	162.06	20	1

LTP NAME AND SIGNATURE	STRUCTURAL ENG'S NAME AND SIGNATURE	BUILDER NAME AND SIGNATURE	DIGITAL SIGNATURE
EJAZ AHMAD MNAC/DFTMN/0008/2020			