

GROUND FLOOR PLAN (Proposed) (SCALE 1:100)

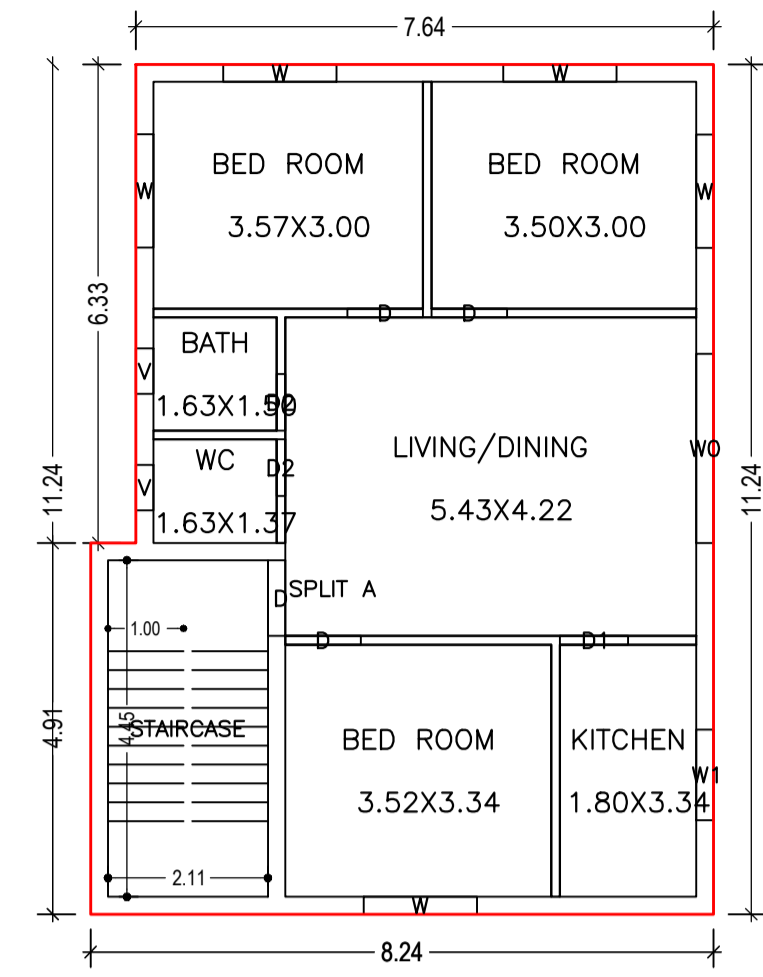

FIRST FLOOR PLAN (Proposed) (SCALE 1:100)

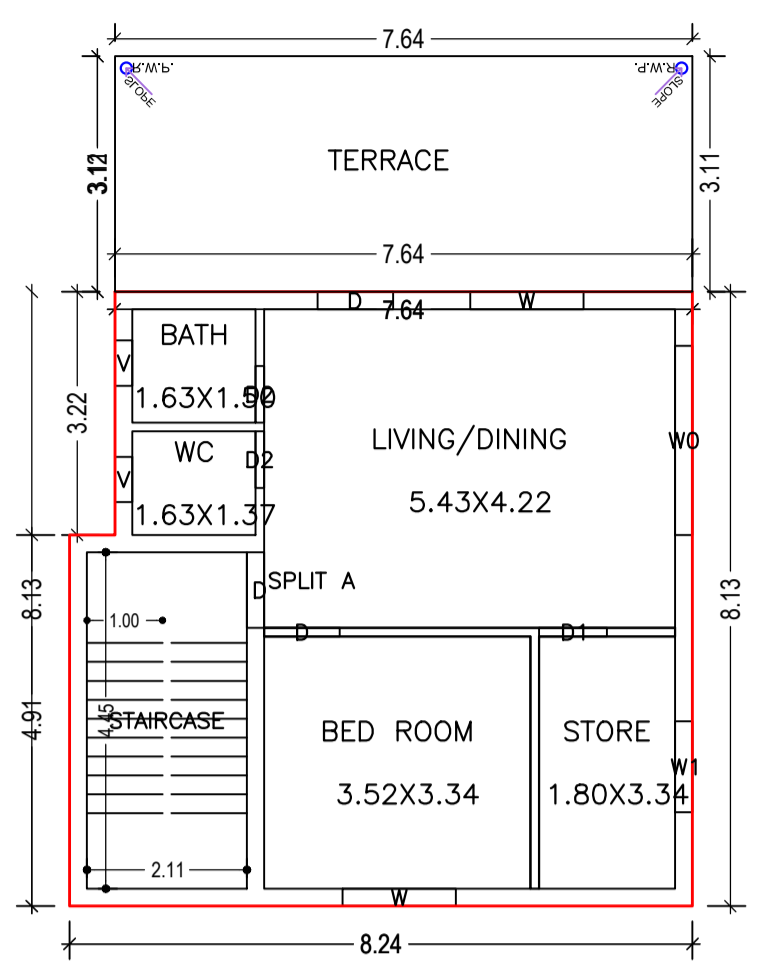

SECOND FLOOR PLAN (Proposed) (SCALE 1:100)

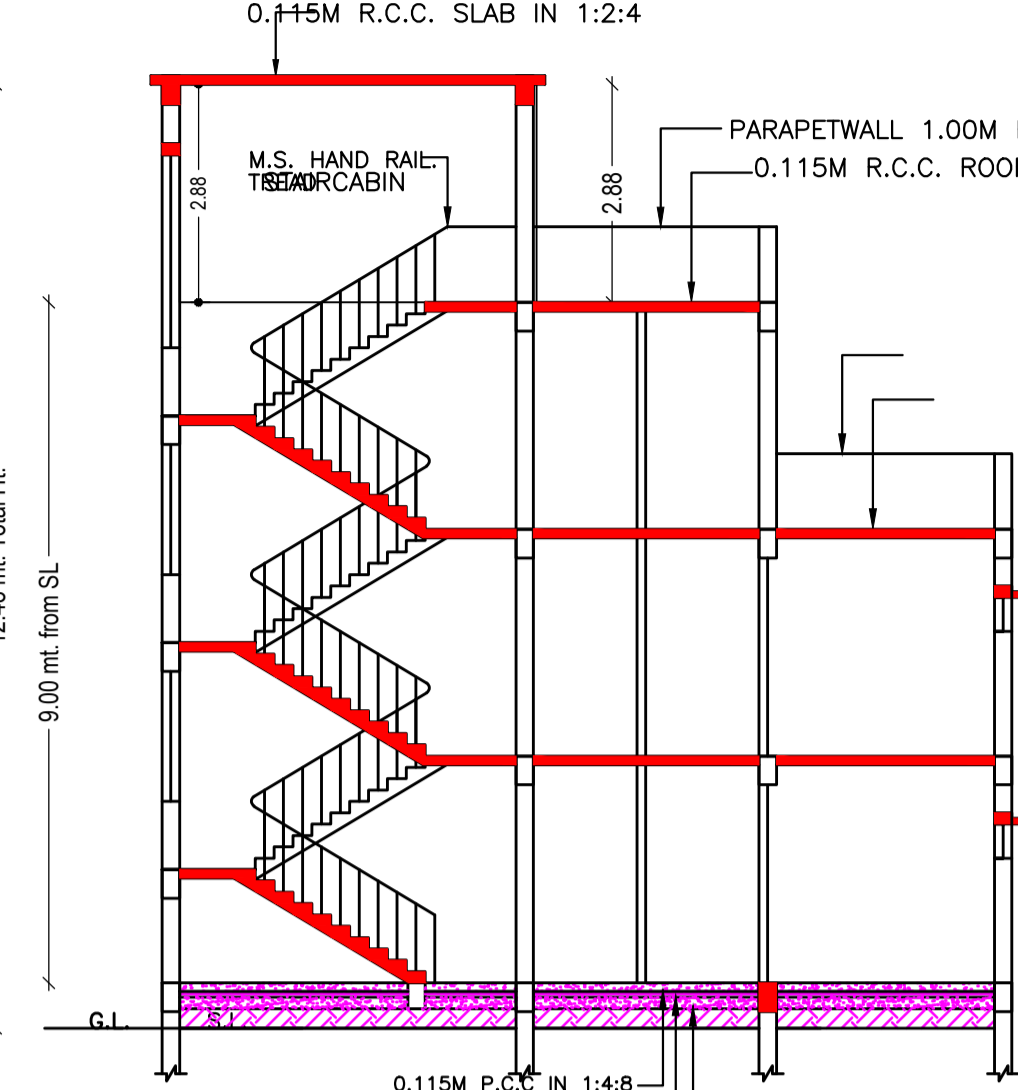

SECTION -A A SCALE 1:100

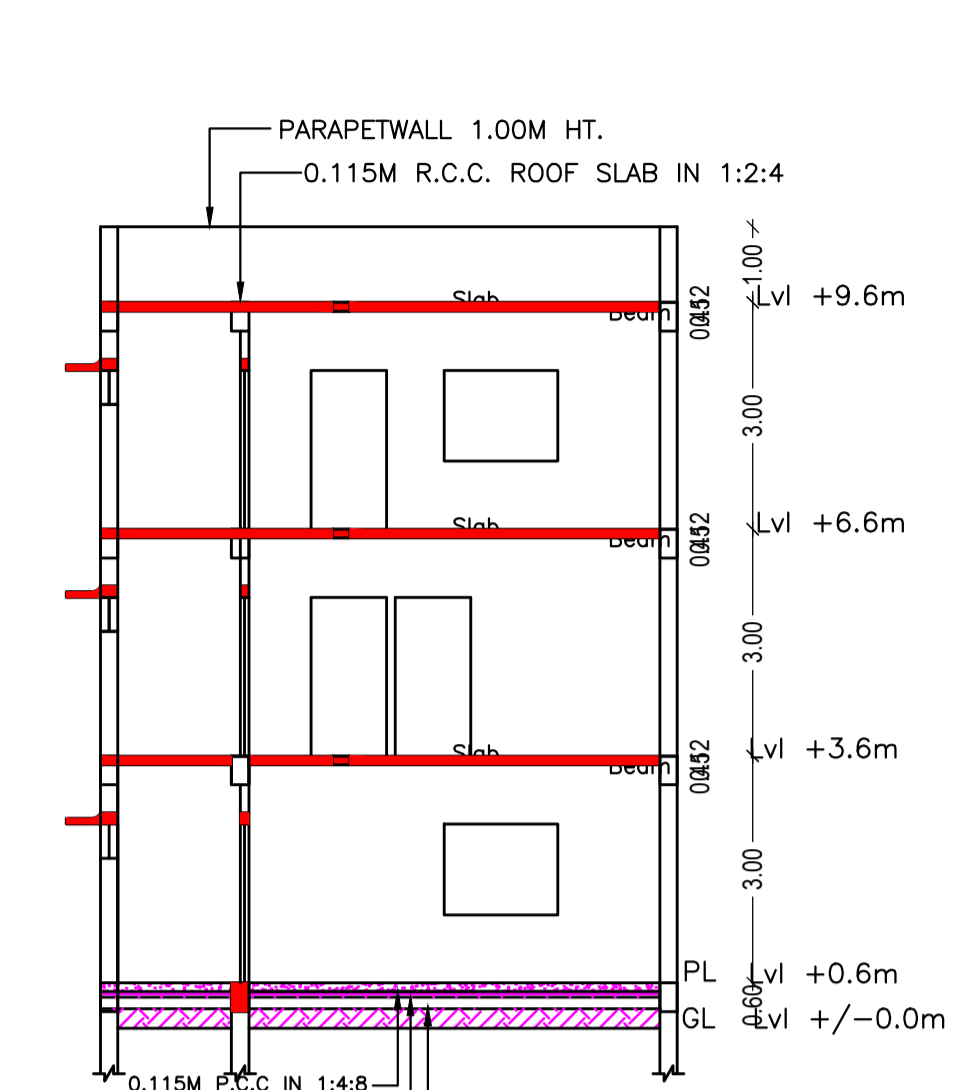

SECTION -B B SCALE 1:100

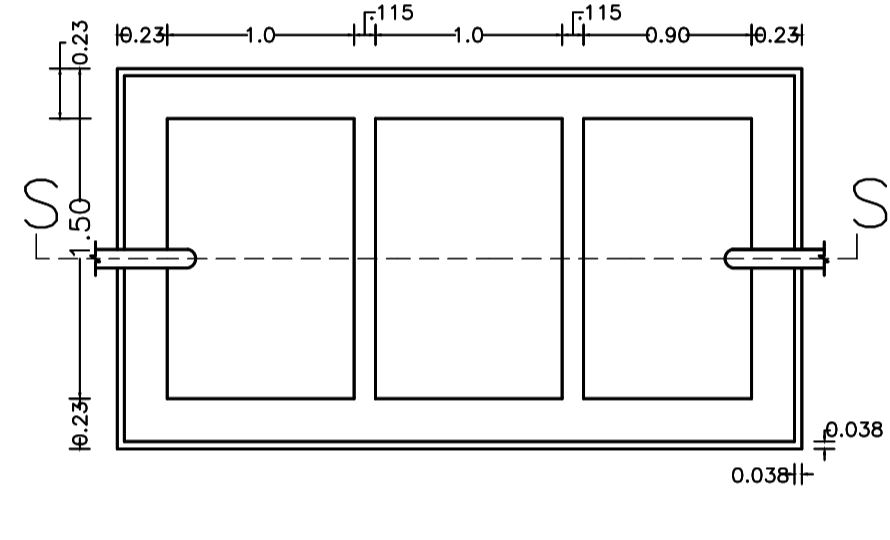

SEPTIC TANK PLAN

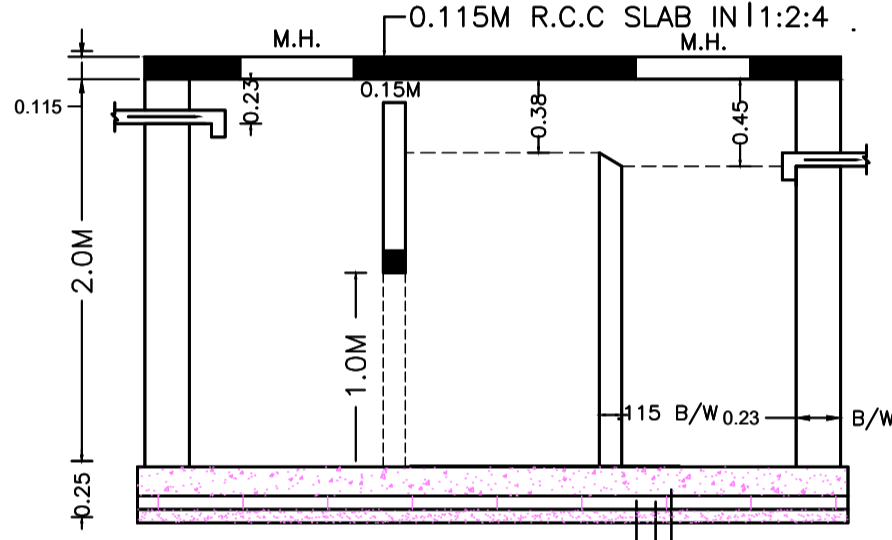

SECTION - SS SCALE - 1:50

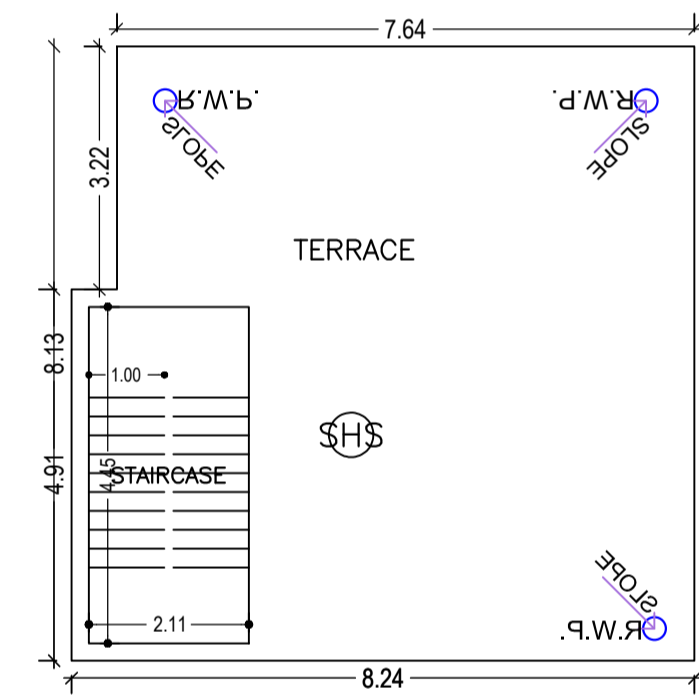

TERRACE FLOOR PLAN (SCALE 1:100)

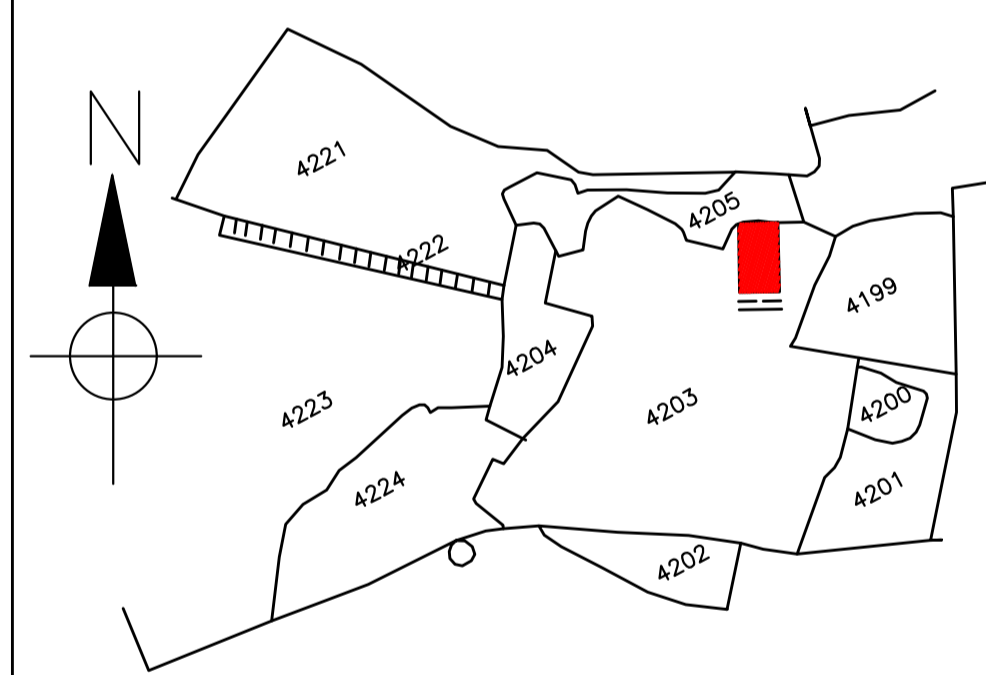

MOUZA PLAN SCALE :- NTS

Buildingwise Floor FAR Details

Floor Name	Building Name A (RESIDENTIAL)		Total	
	Proposed Built Up Area (Sq.mt.)	Proposed FAR Area (Sq.mt.)	Total Proposed Built Up Area (Sq.mt.)	Total FAR Area (Sq.mt.)
Ground Floor	88.82	21.91	88.82	21.91
First Floor	88.82	88.82	88.82	88.82
Second Floor	65.02	65.02	65.02	65.02
Terrace Floor	0.00	0.00	0.00	0.00
<b>Total :</b>	<b>242.66</b>	<b>175.75</b>	<b>242.66</b>	<b>175.75</b>

UnitBUA Table for Building :A (RESIDENTIAL)

FLOOR	Name	UnitBUA Type	UnitBUA Area	Carpet Area	No. of Rooms	No. of Tenement
GROUND FLOOR PLAN	SPLIT A	FLAT	127.88	121.95	3	1
FIRST FLOOR PLAN	SPLIT A	FLAT	0.00	0.00	7	0
SECOND FLOOR PLAN	SPLIT A	FLAT	0.00	0.00	5	0
Terrace Floor	SPLIT A	FLAT	0.00	0.00	5	0
<b>Total:</b>			<b>127.88</b>	<b>121.95</b>	<b>15</b>	<b>1</b>

FAR & Tenement Details (Table 4c-1)

Building	No. of Same Bldg	Total Built Up Area (Sq.mt.)	Deductions (Area in Sq.mt.)	Proposed FAR Area (Sq.mt.)	Add Area in FAR (Sq.mt.)	Total FAR Area (Sq.mt.)	Total Consumed Additional FAR Area (Sq.mt.)	Tnmt (No.)
A (RESIDENTIAL)	1	242.66	66.91	166.34	9.41	175.75	175.75	01
<b>Grand Total :</b>	<b>1</b>	<b>242.66</b>	<b>66.91</b>	<b>166.34</b>	<b>9.41</b>	<b>175.75</b>	<b>175.75</b>	<b>01</b>

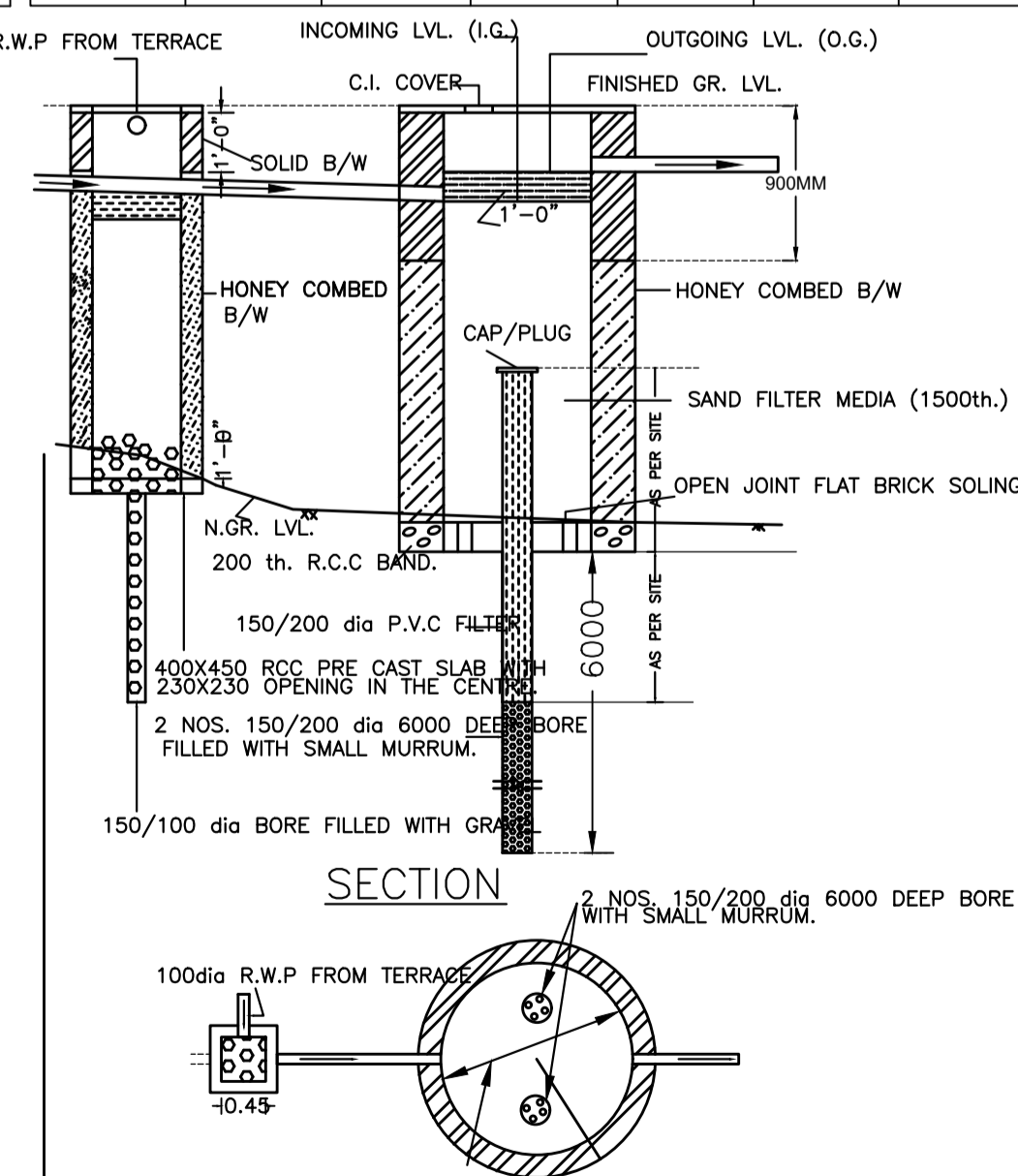

WATER HARVESTING PLAN (NTS)

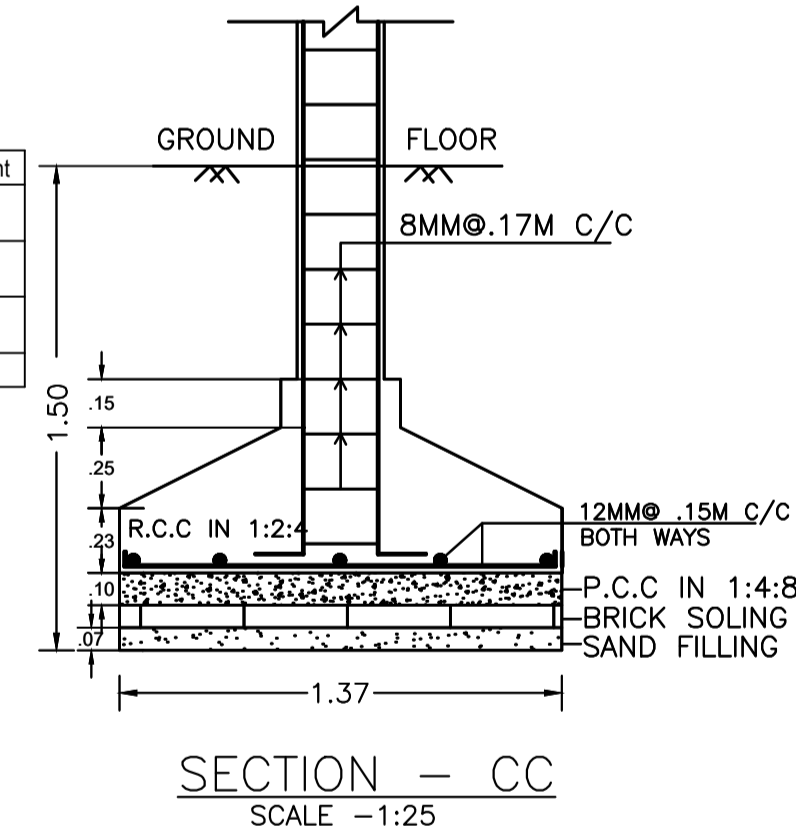

SECTION - CC SCALE - 1:25

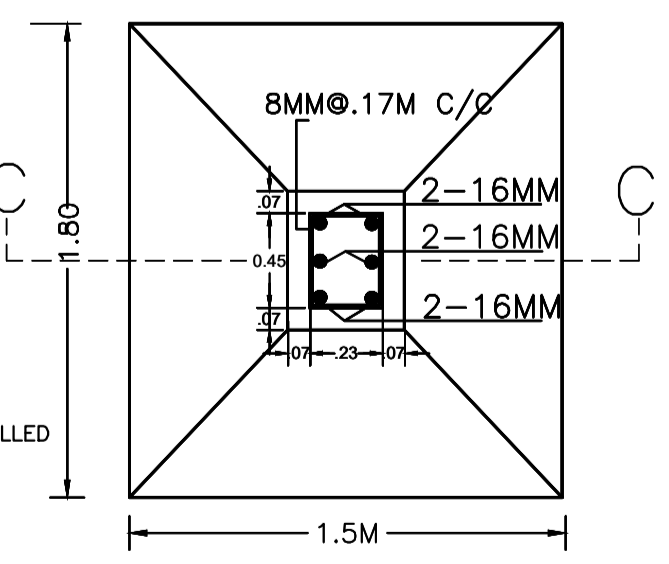

R.C.C. COL. FDN. PLAN SCALE - 1:25

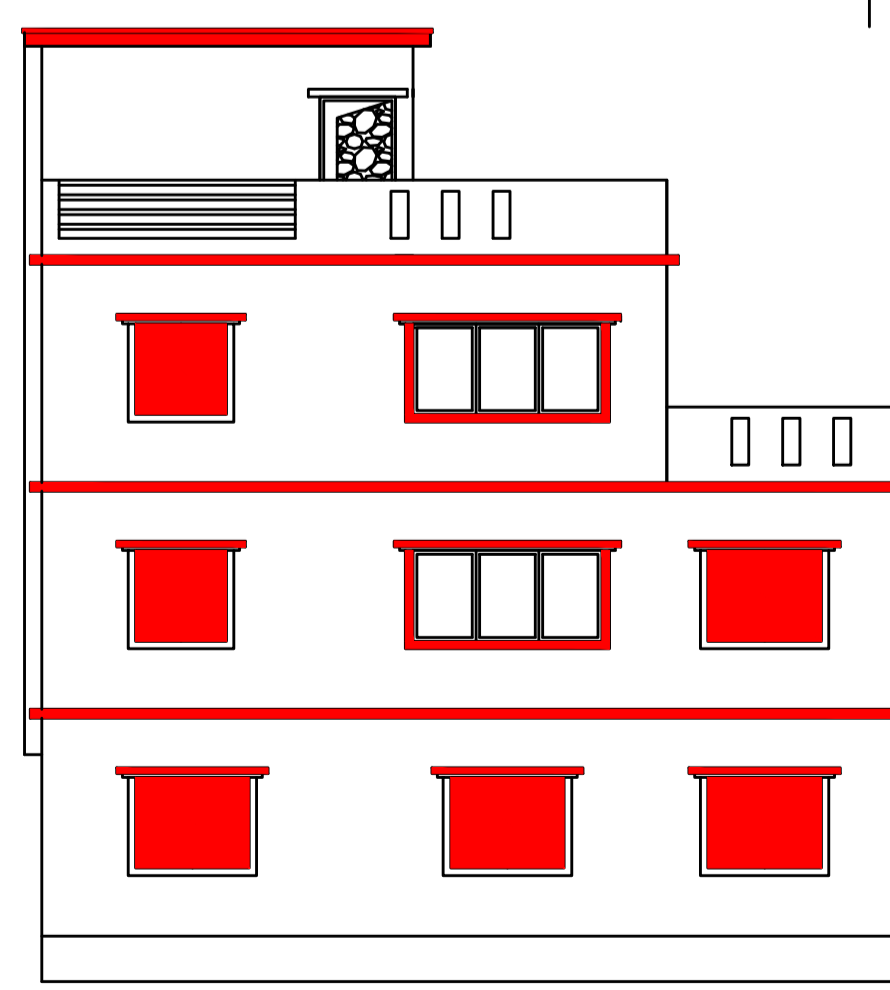

EAST SIDE ELEVATION SCALE 1:100

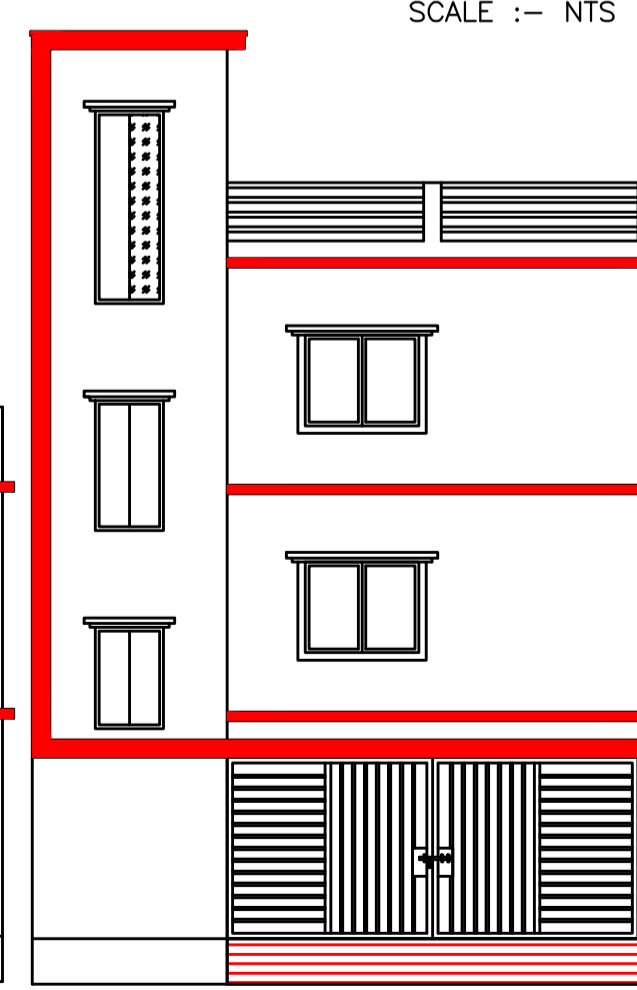

FRONT ELEVATION SCALE 1:100

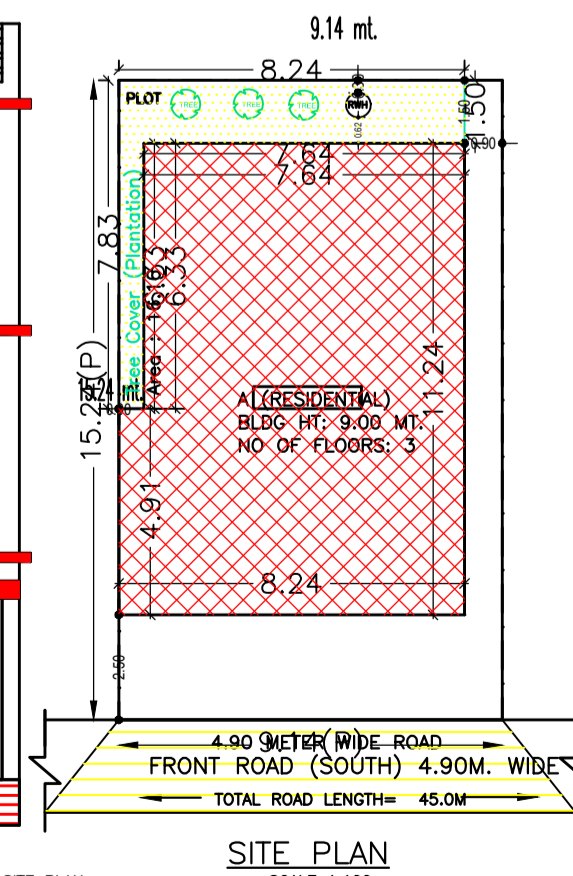

SITE PLAN SCALE 1:100

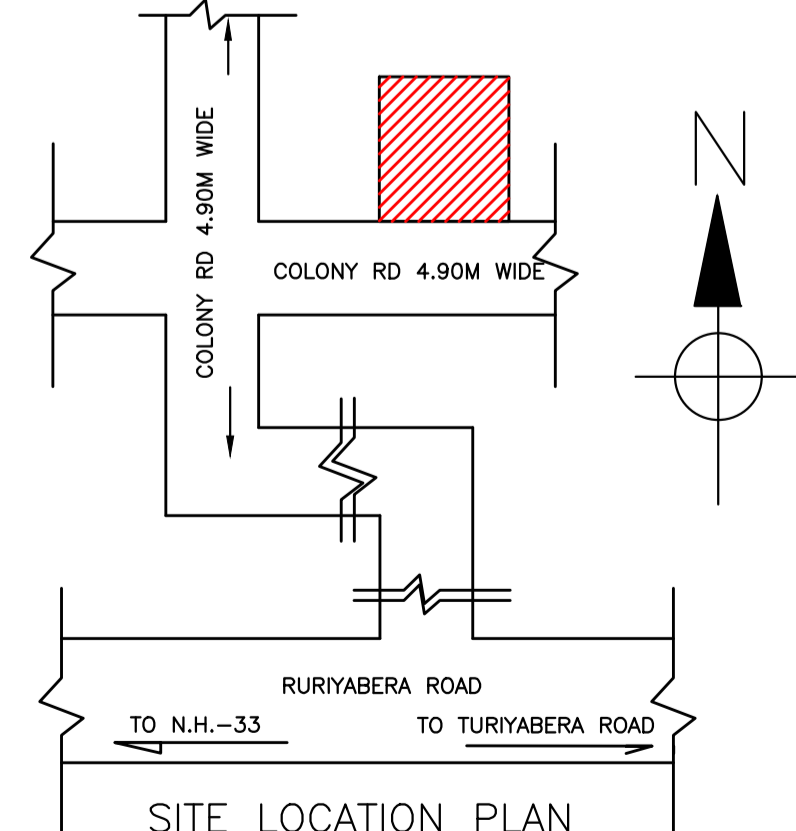

SITE LOCATION PLAN

Proposal Basic Information

Proposal File No.	MNAC/BP/0070/W10/2023
Owner Name	SMT. SUNITA DEVI WO MR. BHAVISHYA KUMAR SHARMA AND MR. BHAVISHYA KUMAR SHARMA SO MR. TARKESHWAR SHARMA
Khata No.	199
Plot No.	4203
Village Name	Baliguma
Use	Residential
SubUse	Bungalow/ Dwelling / Non Apartment

AREA STATEMENT MANGO MUNICIPAL CORPORATION

VERSION NO.:	1.0.66
VERSION DATE:	16/10/2020
PROJECT DETAIL:	
Region: JHARKHAND URBAN LOCAL BODIES	Plot Use: Residential
District: EAST SINGBHUM	Plot SubUse: Bungalow/ Dwelling / Non Apartment
Authority: MANGO MUNICIPAL CORPORATION	PlotNearby/ReligiousStructure: NA
Inward No: MNAC/BP/0070/W10/2023	Plot/SubPlot No: 4203
Application Type: General Proposal	North: Plot No. - 4205
Project Type: Building Permission	South: Road Width - 4.90
Nature of Development: New	East: Plot No. - 4203
Location of Development Area: Old Area	West: Plot No. - 4203

AREA DETAILS:

AREA OF PLOT (Minimum)	(A)	SQ.MT.	139.29
NET AREA OF PLOT(Gross Plot Area - Deduction from Gross Plot area)	(A-Deductions)		139.29
Deduction for Balance Plot Area(from Gross Plot Area)			16.16
Common Plot			16.16
BALANCE AREA OF PLOT(Net Plot Area - Recreational/Amenity space)	(A-Deductions)		123.13
PLOT AREA FOR COVERAGE(Net Plot Area)	(A-Deductions)		139.29
Plot Area for FAR (Net Plot Area + RoadWidening Area)	(A-Deductions)		139.29

COVERAGE CHECK

Permissible Coverage area ( 70.00 % )	97.50
Proposed Coverage Area ( 63.77 % )	88.82
Total Prop. Coverage Area ( 63.77 % )	88.82
Balance coverage area ( 6.23 % )	8.68

FAR CHECK

Perm. FAR Area ( 1.800 )	250.72
Total Perm. FAR area	250.72
Residential FAR	166.34
Proposed FAR Area	175.75
Total Proposed FAR Area	175.75
Consumed FAR (Factor)	1.26
Balance FAR Area	74.97

BUILT UP AREA CHECK

Total Proposed BuiltUp Area	242.66
ARCHITECT (Regd)	Chandrika Sharma
ENGINEER (Regd)	
SUPERVISOR (Regd)	
OWNER (Regd)	SMT. SUNITA DEVI WO MR. BHAVISHYA KUMAR SHARMA AND MR. BHAVISHYA KUMAR SHARMA SO MR. TARKESHWAR SHARMA
DEVELOPMENT AUTHORITY	LOCAL BODY

SCHEDULE OF DOOR:

BUILDING NAME	NAME	LENGTH	HEIGHT	NOS
A (RESIDENTIAL)	D2	0.75	2.10	06
A (RESIDENTIAL)	D1	0.90	2.10	03
A (RESIDENTIAL)	D	1.00	2.10	07

SCHEDULE OF WINDOW/VENTILATION:

BUILDING NAME	NAME	LENGTH	HEIGHT	NOS
A (RESIDENTIAL)	V	0.60	0.90	07
A (RESIDENTIAL)	W1	1.20	1.20	02
A (RESIDENTIAL)	W	1.50	1.20	07
A (RESIDENTIAL)	W0	2.50	1.20	02

Building USE/SUBUSE Details

Building Name	Building Use	Building SubUse	Building Structure
A (RESIDENTIAL)	Residential	Residential Bldg/Apartment	Non-Highrise

LTP NAME AND SIGNATURE	STRUCTURAL ENG'S NAME AND SIGNATURE	BUILDER NAME AND SIGNATURE	DIGITAL SIGNATURE
Chandrika Sharma MNAC/DFTMN/0017/2017			