

SITE PLAN
SCALE 1:100

SITE PLAN

FAR & Tenement Details (Table 4c-1)

Building	No. of Same Bldg	Total Built Up Area (Sq.mt.)	Deductions (Area in Sq.mt.)		Proposed FAR Area (Sq.mt.)	Add Area In FAR (Sq.mt.)	Total FAR Area (Sq.mt.)	Total Consumed Additional FAR Area (Sq.mt.)	Trmnt (No.)
			Parking	Resi.					
A (RESIDENTIAL)	1	232.56	61.75	158.95	11.86	170.81	170.81	01	
Grand Total :	1	232.56	61.75	158.95	11.86	170.81	170.81	01	

Proposal Basic Information

Proposal File No.	MNAC/BP/0006/W09/2023
Owner Name	MR. SHIV CHARAN GOUR
Khata No	281
Plot No	2150(p)
Village Name	Mango
Use	Residential
SubUse	Bungalow/ Dwelling / Non Apartment

AREA STATEMENT MANGO MUNICIPAL CORPORATION	VERSION NO: 1.0.65
	VERSION DATE: 16/10/2020
PROJECT DETAIL:	
Region: JHARKHAND URBAN LOCAL BODIES	Plot Use: Residential
District: EAST SINGBHUM	Plot SubUse: Bungalow/ Dwelling / Non Apartment
Authority: MANGO MUNICIPAL CORPORATION	PlotNearbyReligiousStructure: NA
Inward No: MNAC/BP/0006/W09/2023	PlotSubPlot No: 2150(p)
Application Type: General Proposal	North: Plot No. - 2150
Project Type: Building Permission	South: Plot No. - 2147
Nature of Development: New	East: Plot No. - 2150
Location of Development Area: Old Area	West: Road Width - 6.10
AREA DETAILS:	
AREA OF PLOT (Minimum)	(A) 120.00
NET AREA OF PLOT(Gross Plot Area - Deduction from Gross Plot area)	(A-Deductions) 120.00
Deduction for Balance Plot Area(from Gross Plot Area)	
Common Plot	10.80
Total	10.80
BALANCE AREA OF PLOT(Net Plot Area - Recreational/Amenity space)	(A-Deductions) 109.20
PLOT AREA FOR COVERAGE(Net Plot Area)	(A-Deductions) 120.00
Plot Area for FAR (Net Plot Area + RoadWidening Area)	(A-Deductions) 120.00
COVERAGE CHECK	
Permissible Coverage area (70.00 %)	84.00
Proposed Coverage Area (64.60 %)	77.52
Total Prop. Coverage Area (64.6 %)	77.52
Balance coverage area (5.40 %)	6.48
FAR CHECK	
Perm. FAR Area (2.500)	300.00
Total Perm. FAR area	300.00
Residential FAR	158.95
Proposed FAR Area	170.81
Total Proposed FAR Area	170.81
Consumed FAR (Factor)	1.42
Balance FAR Area	129.19
BUILT UP AREA CHECK	
Total Proposed BuiltUp Area	232.56
ARCHITECT (Regd)	Chandrika Sharma
ENGINEER (Regd)	
SUPERVISOR (Regd)	
OWNER (Regd)	MR. SHIV CHARAN GOUR
DEVELOPMENT AUTHORITY	
	LOCAL BODY

COLOR INDEX	
PLOT BOUNDARY	Black
ABUTTING ROAD	Green
PROPOSED CONSTRUCTION	Red
COMMON PLOT	Yellow
ROAD WIDENING AREA	Orange
EXISTING (To be retained)	Blue
EXISTING (To be demolished)	Light Blue

Buildingwise Floor FAR Details

Floor Name	Building Name A (RESIDENTIAL)		Total	
	Proposed Built Up Area (Sq.mt.)	Proposed FAR Area (Sq.mt.)	Total Proposed Built Up Area (Sq.mt.)	Total FAR Area (Sq.mt.)
Ground Floor	77.52	15.77	77.52	15.77
First Floor	77.52	77.52	77.52	77.52
Second Floor	77.52	77.52	77.52	77.52
Terrace Floor	0.00	0.00	0.00	0.00
Total :	232.56	170.81	232.56	170.81

Building USE/SUBUSE Details

Building Name	Building Use	Building SubUse	Building Structure
A (RESIDENTIAL)	Residential	Bungalow/ Dwelling / Non Apartment	Non-Highrise

LTP NAME AND SIGNATURE	STRUCTURAL ENG'S NAME AND SIGNATURE	BUILDER NAME AND SIGNATURE	DIGITAL SIGNATURE
Chandrika Sharma MNAC/DFTMN/0017/2017			

Proposal Basic Information	
Proposal File No.	MNAC/BP/0006/W09/2023
Owner Name	MR. SHIV CHARAN GOUR
Khata No	281
Plot No	2150(p)
Village Name	Mango
Use	Residential
SubUse	Bungalow/ Dwelling / Non Apartment

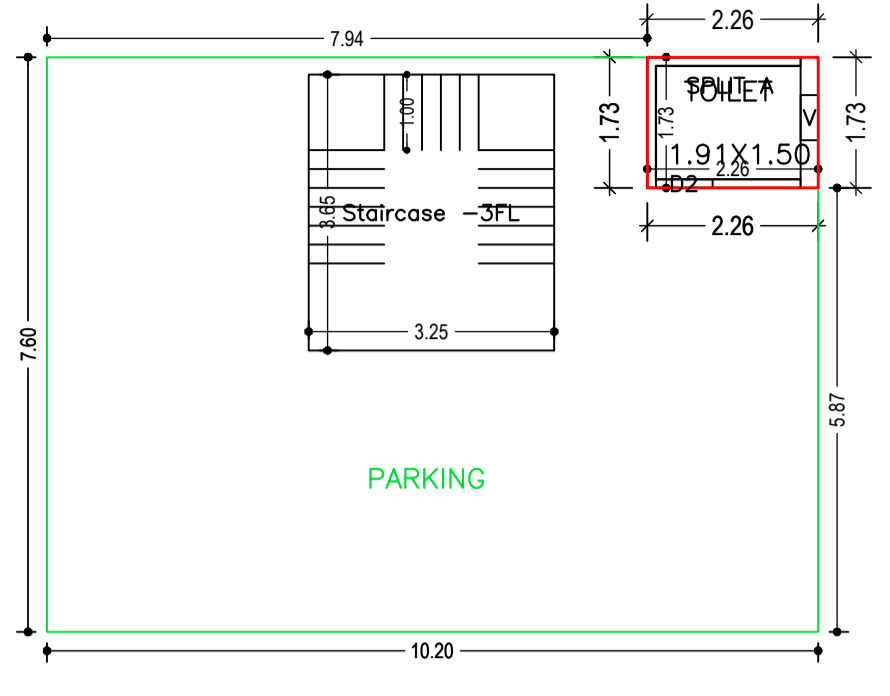

GROUND FLOOR PLAN (Proposed) (SCALE 1:100)

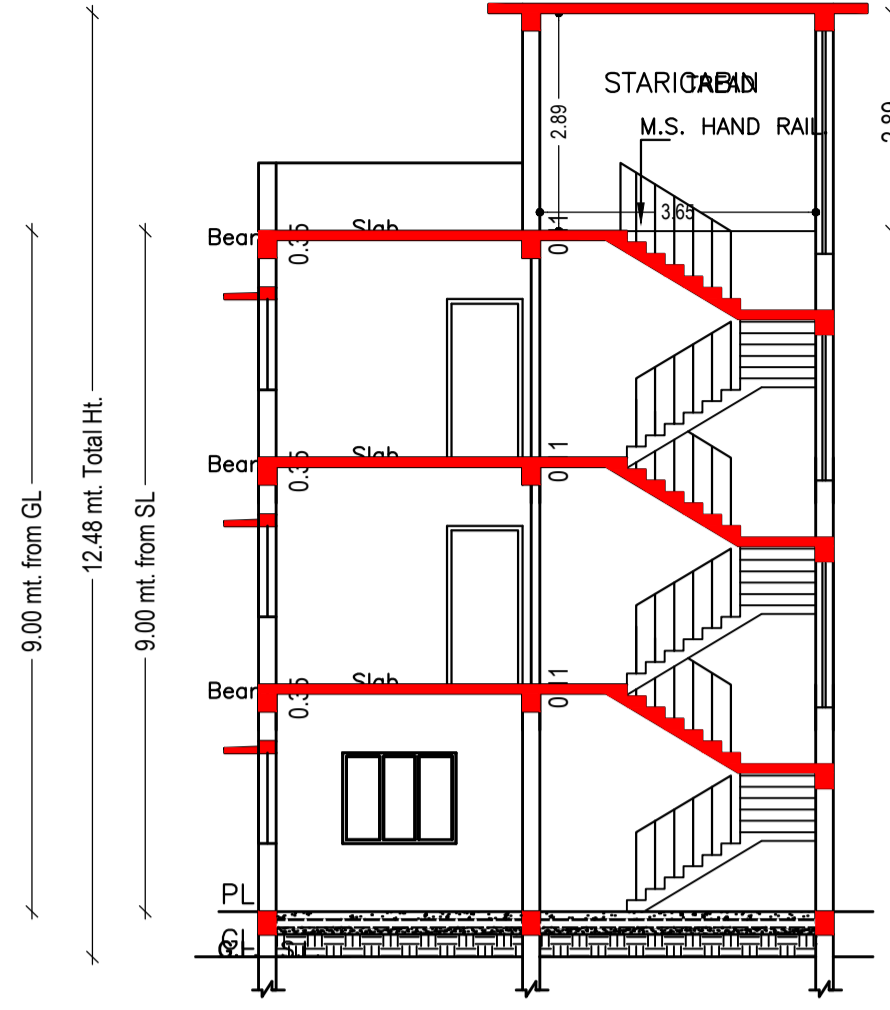

SECTION A A (SCALE 1:100)

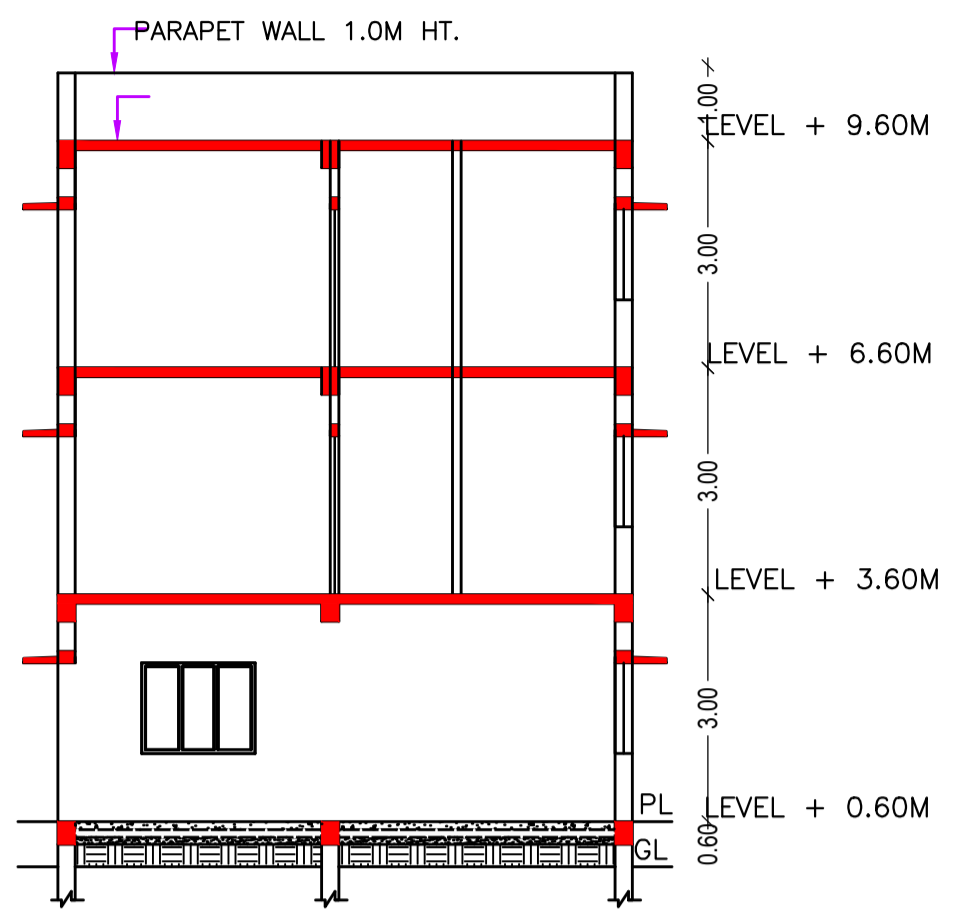

SECTION B B (SCALE 1:100)

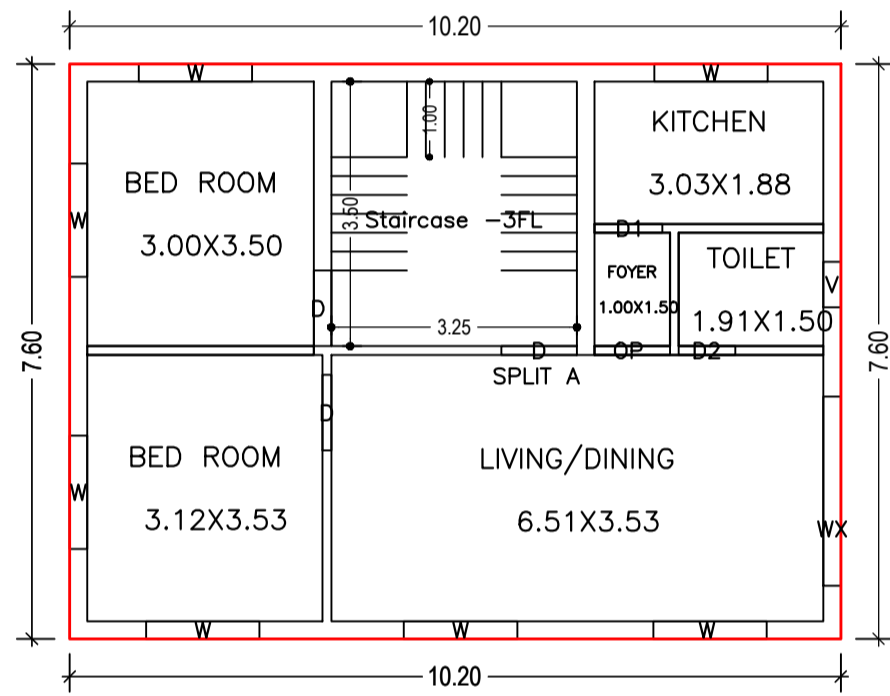

TYPICAL - 1& 2 FLOOR PLAN (Proposed) (SCALE 1:100)

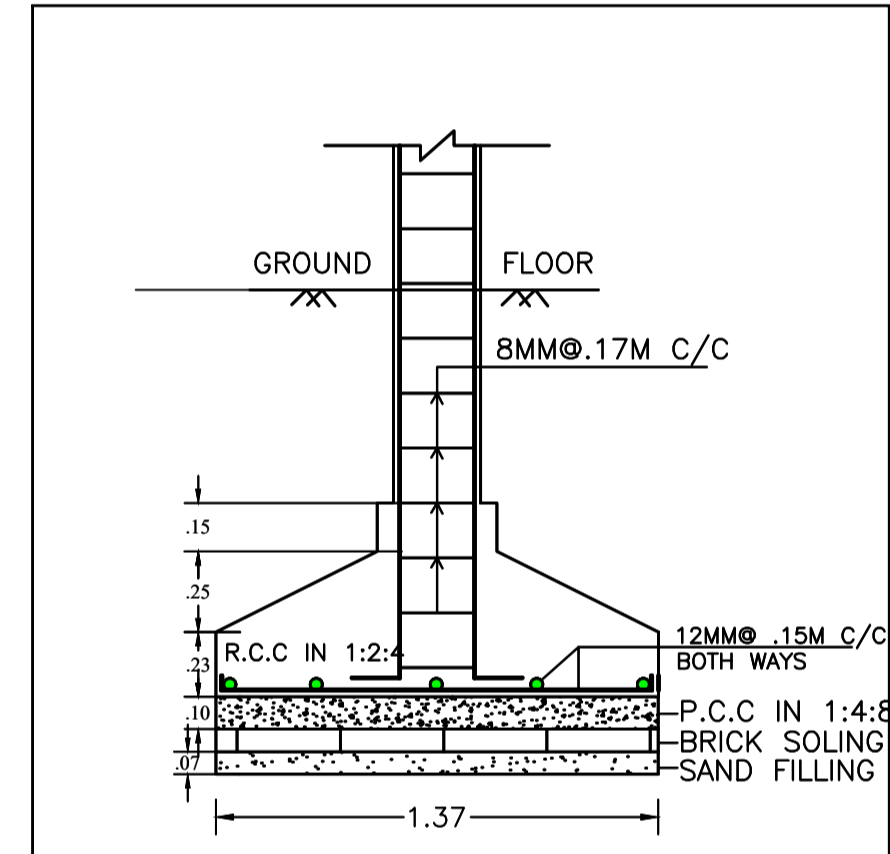

SECTION - CC (SCALE -1:25)

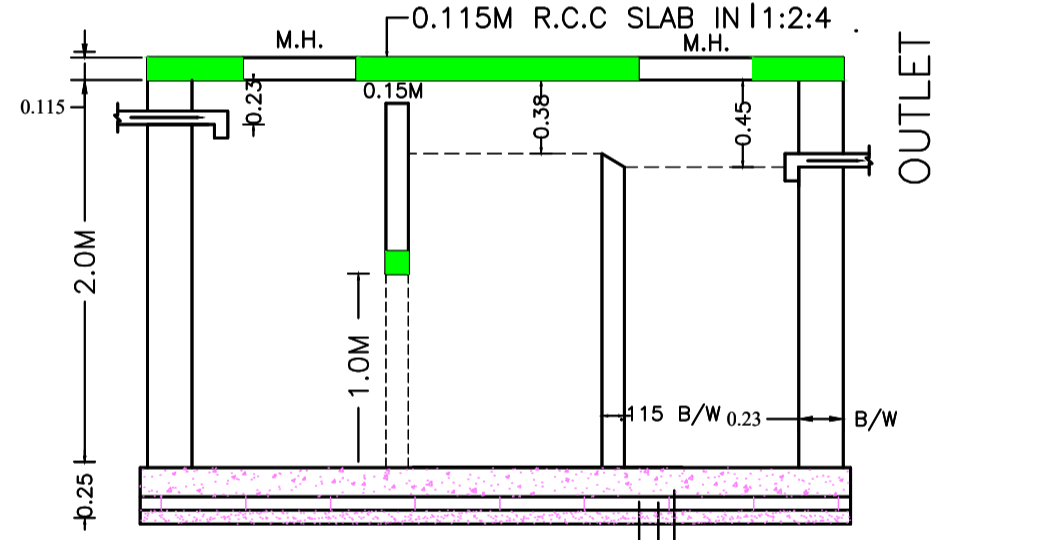

SECTION - SS (SCALE -1:50)

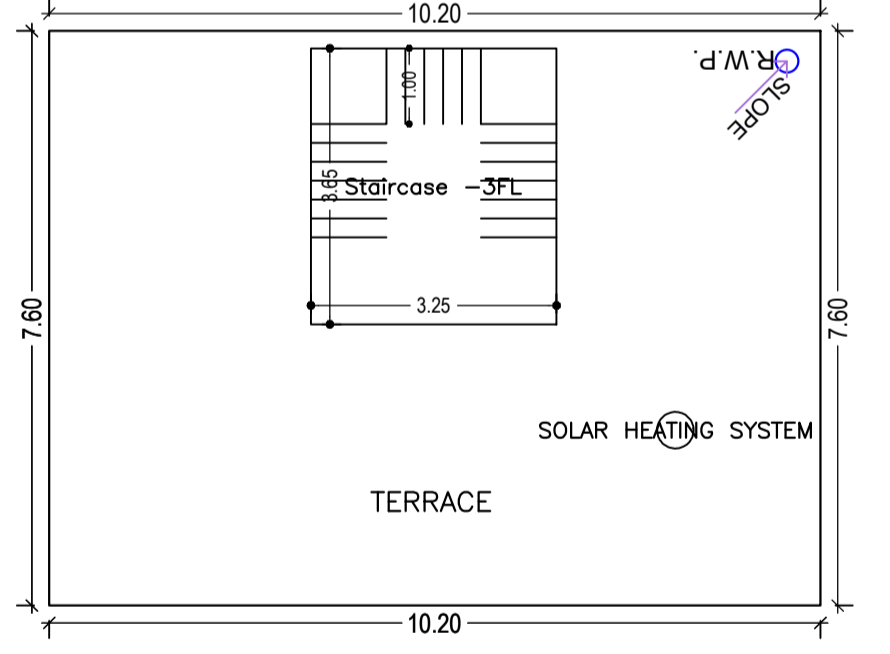

TERRACE FLOOR PLAN (SCALE 1:100)

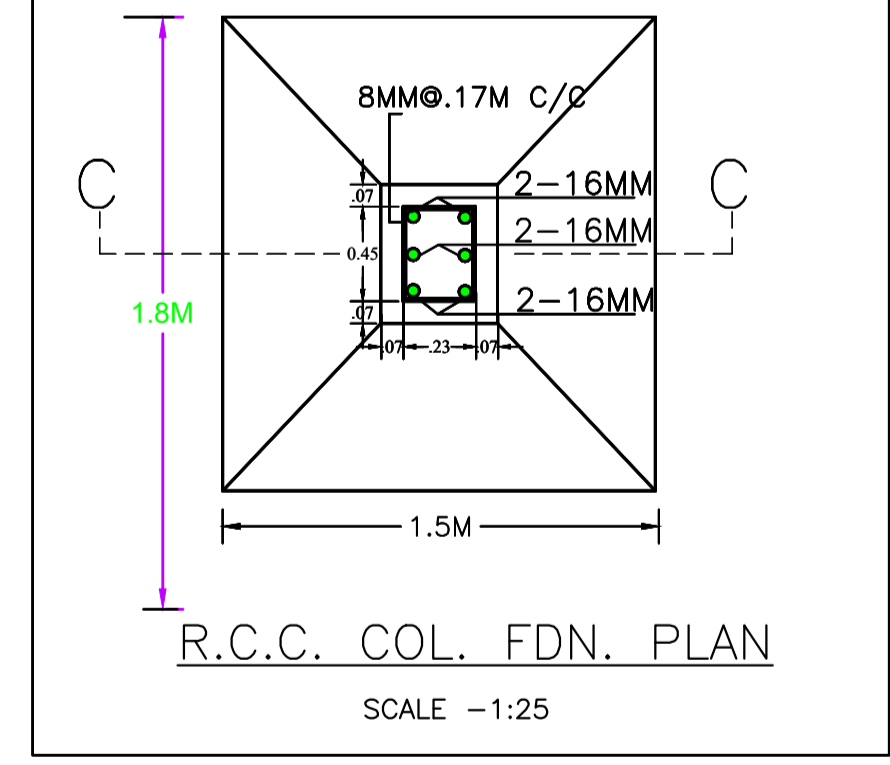

R.C.C. COL. FDN. PLAN (SCALE -1:25)

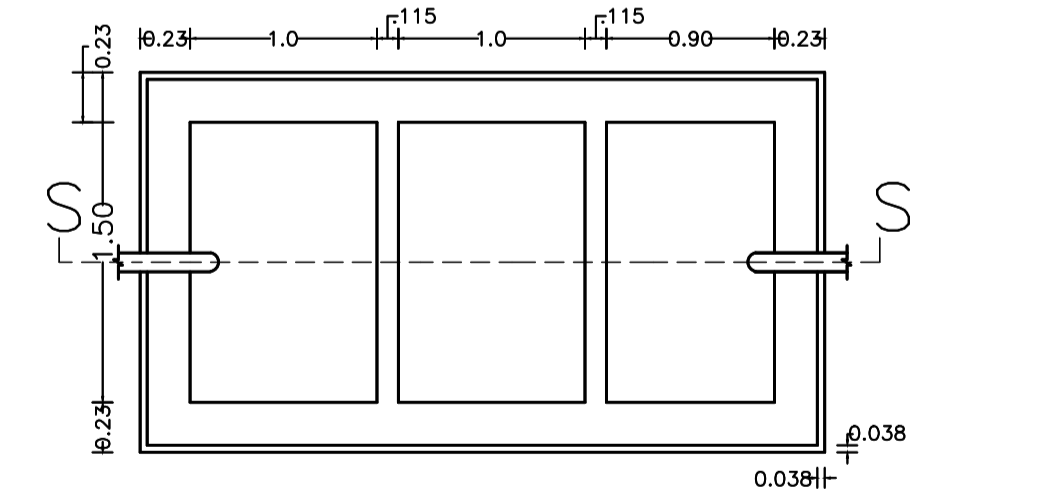

SEPTIC TANK PLAN

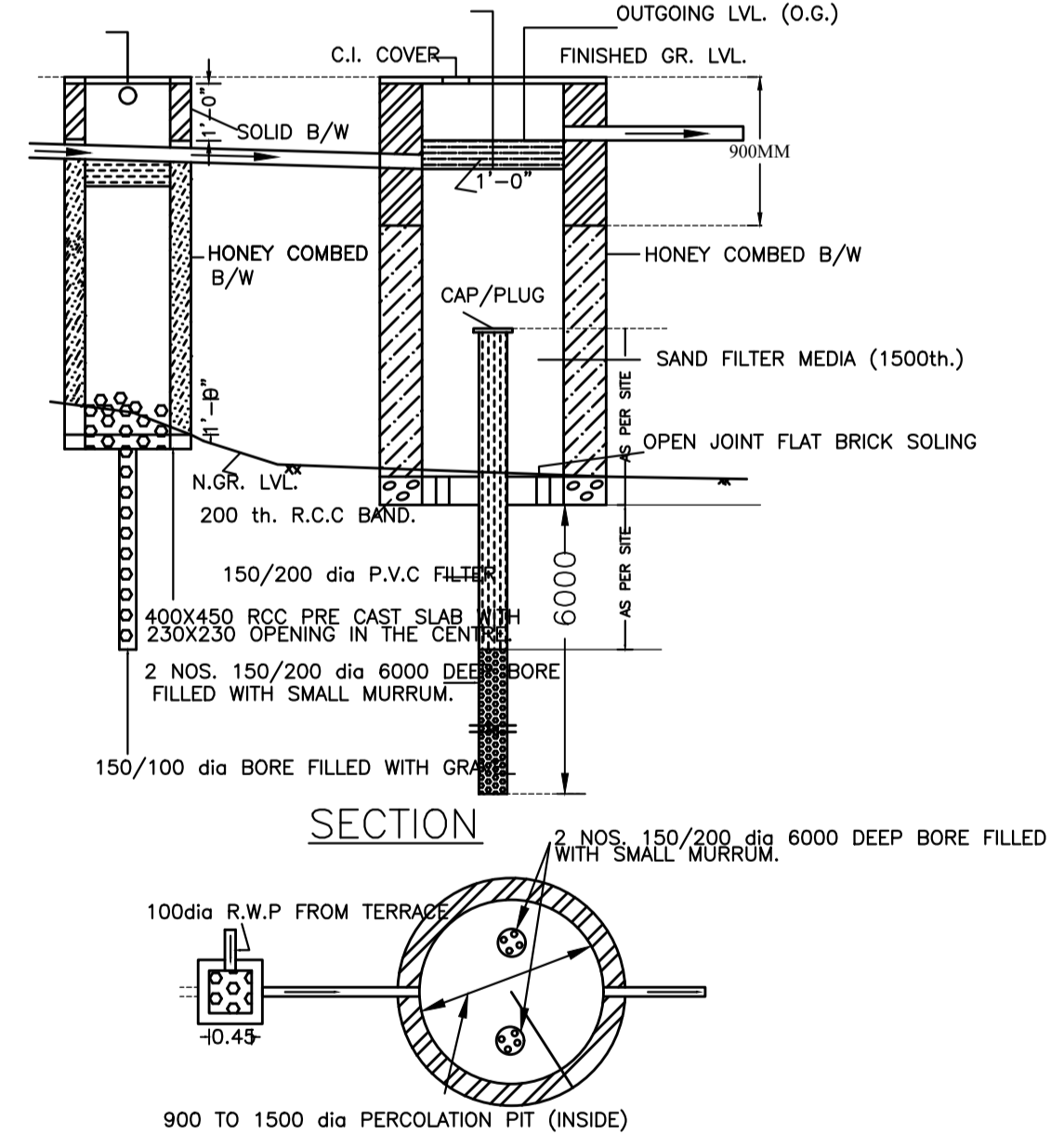

WATER HARVESTING PLAN (NTS)

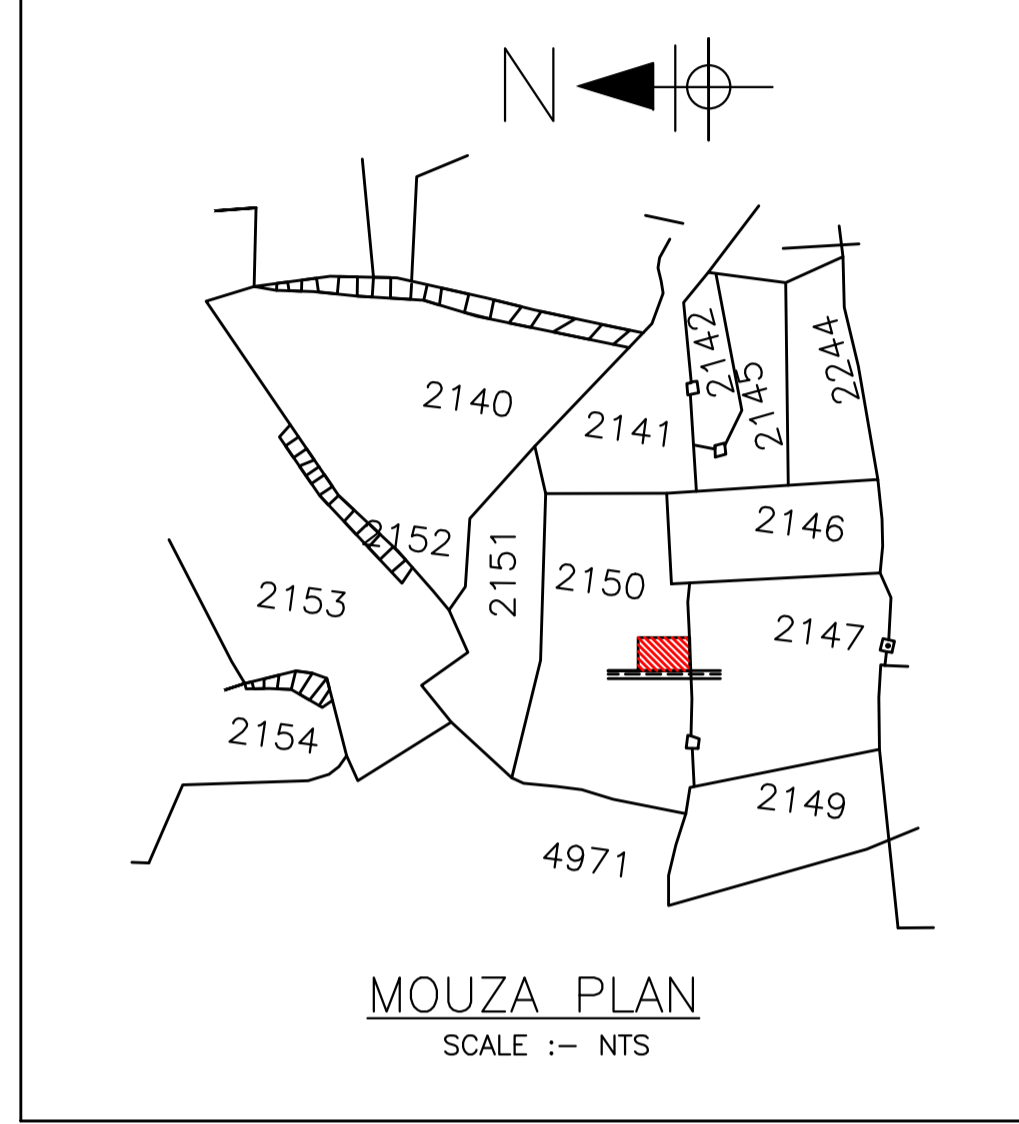

MOUZA PLAN (SCALE :- NTS)

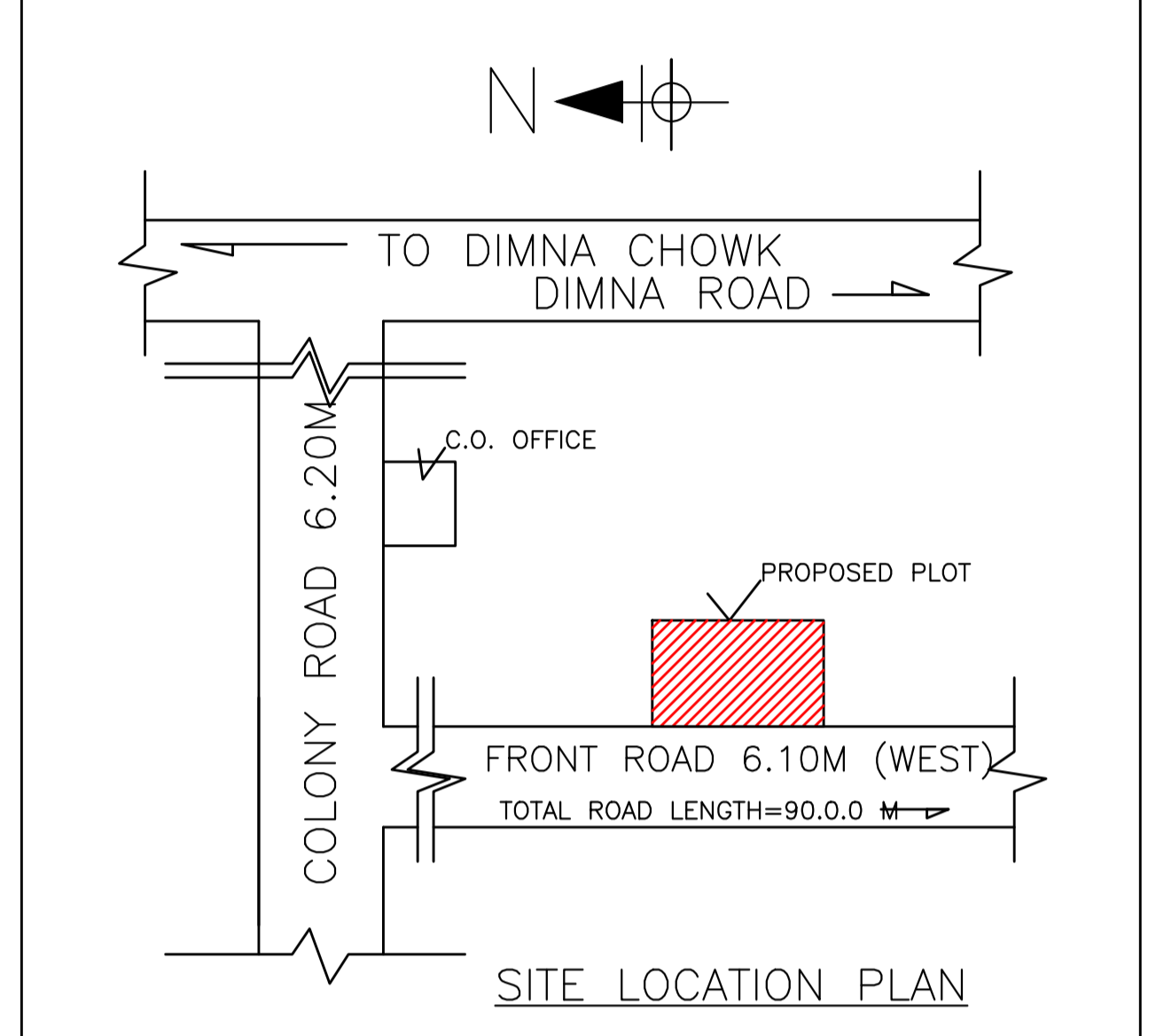

SITE LOCATION PLAN

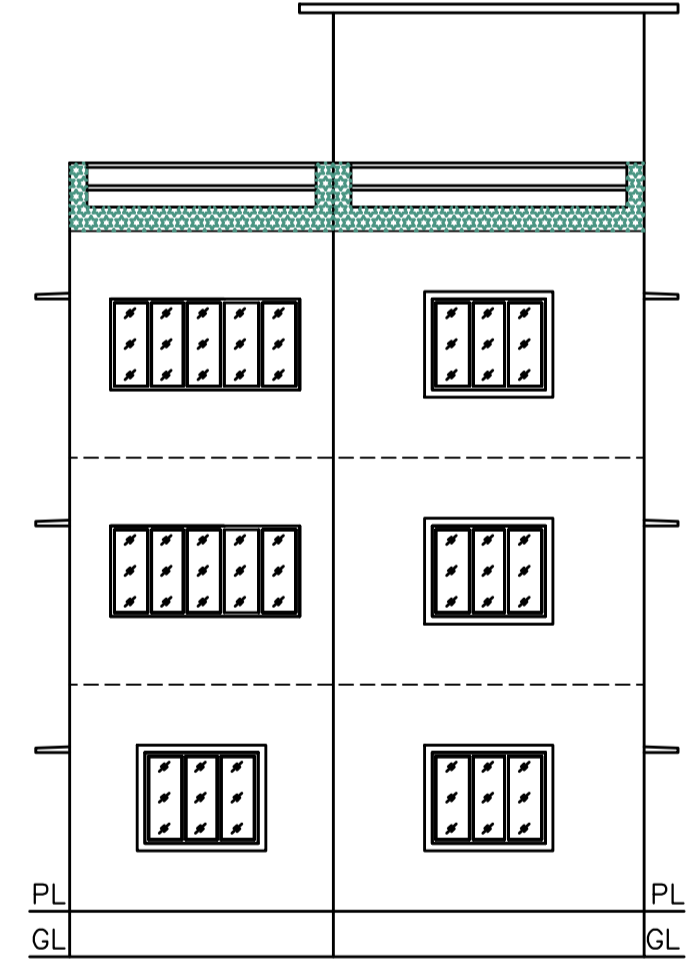

SOUTH SIDE ELEVATION (SCALE 1:100)

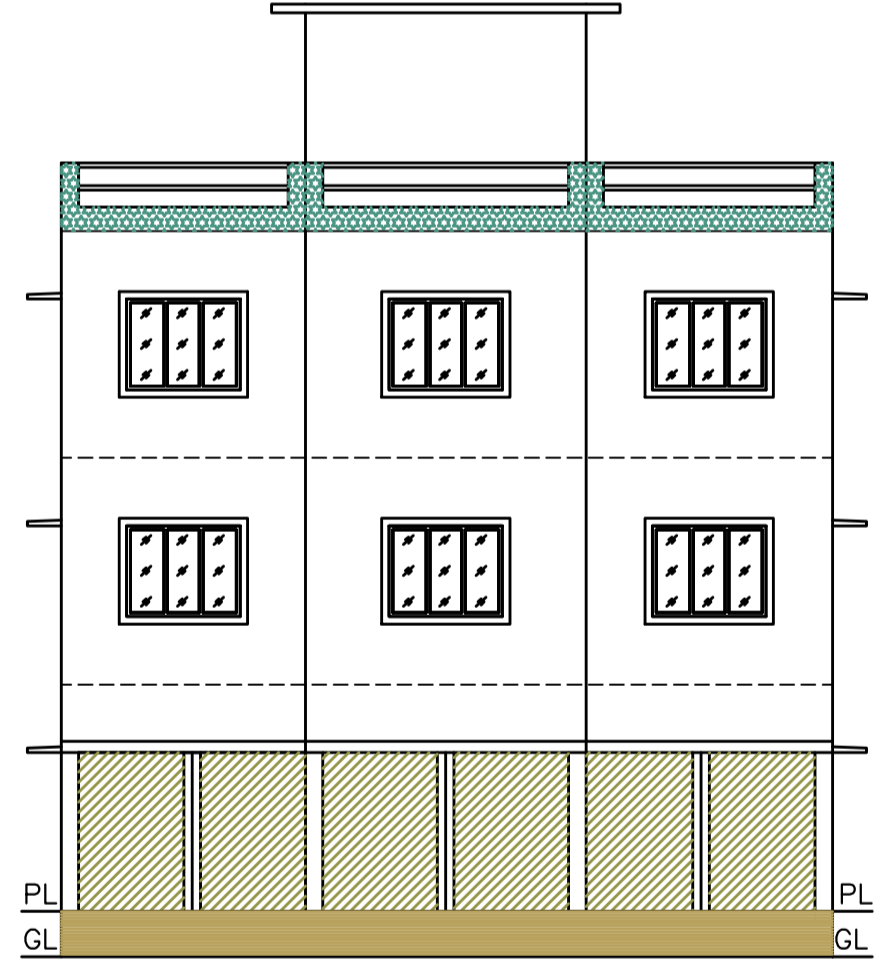

FRONT ELEVATION (SCALE 1:100)

Building :A (RESIDENTIAL)

Floor Name	Total Built Up Area (Sq.mt)	Deductions (Area in Sq.mt)	Proposed FAR Area (Sq.mt)	Add Area in FAR (Sq.mt)	Total FAR Area (Sq.mt)	Total Consumed Additional FAR Area (Sq.mt)	Trmt (No.)
Ground Floor	77.52	61.75	3.91	11.86	15.77	15.77	01
First Floor	77.52	0.00	77.52	0.00	77.52	77.52	00
Second Floor	77.52	0.00	77.52	0.00	77.52	77.52	00
Terrace Floor	0.00	0.00	0.00	0.00	0.00	0.00	00
Total :	232.56	61.75	158.95	11.86	170.81	170.81	01
Total Number of Same Buildings	1						
Total :	232.56	61.75	158.95	11.86	170.81	170.81	01

SCHEDULE OF DOOR:

BUILDING NAME	NAME	LENGTH	HEIGHT	NOS
A (RESIDENTIAL)	D2	0.75	2.10	03
A (RESIDENTIAL)	D1	0.90	2.10	02
A (RESIDENTIAL)	D	1.00	2.10	06
A (RESIDENTIAL)	OP	1.00	2.10	02

SCHEDULE OF WINDOW/VENTILATION:

BUILDING NAME	NAME	LENGTH	HEIGHT	NOS
A (RESIDENTIAL)	V	0.60	0.90	03
A (RESIDENTIAL)	W	1.50	1.20	14
A (RESIDENTIAL)	WX	2.50	1.20	02

UnitBUA Table for Building :A (RESIDENTIAL)

FLOOR	Name	UnitBUA Type	UnitBUA Area	Carpet Area	No. of Rooms	No. of Tenement
GROUND FLOOR PLAN	SPLIT A	FLAT	116.17	113.11	1	1
TYPICAL - 1& 2 FLOOR PLAN	SPLIT A	FLAT	0.00	0.00	6	0
Total:	-	-	116.17	113.11	13	1

LTP NAME AND SIGNATURE	STRUCTURAL ENG'S NAME AND SIGNATURE	BUILDER NAME AND SIGNATURE	DIGITAL SIGNATURE
Chandrika Sharma MNAC/DFTMN/0017/2017			