

STE PLAN
SCALE 1:100

SITE PLAN

FAR & Tenement Details (Table 4c-1)

Building	No. of Same Bldg	Total Built Up Area (Sq.mt.)	Deductions (Area in Sq.mt.)	Proposed FAR Area (Sq.mt.)	Total FAR Area (Sq.mt.)	Total Consumed Additional FAR Area (Sq.mt.)	Tnmt (No.)
A (RESIDENTIAL)	1	342.93	78.09	264.84	264.84	264.84	01
Grand Total :	1	342.93	78.09	264.84	264.84	264.84	01

Proposal Basic Information

Proposal File No.	MNAC/BP/0005/W10/2023
Owner Name	MR. BALIRAM SINGH
Khata No	269
Plot No	3730
Village Name	Mango
Use	Residential
SubUse	Bungalow/ Dwelling / Non Apartment

AREA STATEMENT MANGO MUNICIPAL CORPORATION	VERSION NO: 1.0.65	VERSION DATE: 16/10/2020
PROJECT DETAIL:		
Region: JHARKHAND URBAN LOCAL BODIES	Plot Use: Residential	
District: EAST SINGHBHUM	Plot SubUse: Bungalow/ Dwelling / Non Apartment	
Authority: MANGO MUNICIPAL CORPORATION	PlotNearbyReligiousStructure: NA	
Inward No: MNAC/BP/0005/W10/2023	PlotSubPlot No: 3730	
Application Type: General Proposal	North: Plot No. - 3852	
Project Type: Building Permission	South: Road Width - 4.80	
Nature of Development: New	East: Plot No. - 3732	
Location of Development Area: Old Area	West: Plot No. - 3730	
AREA DETAILS:		
AREA OF PLOT (Minimum)	(A)	SQ.MT. 206.75
NET AREA OF PLOT(Gross Plot Area - Deduction from Gross Plot area)	(A-Deductions)	206.75
Deduction for Balance Plot Area(from Gross Plot Area)		
Common Plot		16.83
Total		16.83
BALANCE AREA OF PLOT(Net Plot Area - Recreational/Amenity space)	(A-Deductions)	189.92
PLOT AREA FOR COVERAGE(Net Plot Area)	(A-Deductions)	206.75
Plot Area for FAR (Net Plot Area + Road Widening Area)	(A-Deductions)	206.75
COVERAGE CHECK		
Permissible Coverage area (70.00 %)		144.72
Proposed Coverage Area (55.29 %)		114.31
Total Prop. Coverage Area (55.29 %)		114.31
Balance coverage area (14.71 %)		30.41
FAR CHECK		
Perm. FAR Area (1.800)		372.15
Total Perm. FAR area		372.15
Residential FAR		264.85
Proposed FAR Area		264.85
Total Proposed FAR Area		264.85
Consumed FAR (Factor)		1.28
Balance FAR Area		107.30
BUILT UP AREA CHECK		
Total Proposed BuiltUp Area		342.93
ARCHITECT (Regd)	Chandrika Sharma	
ENGINEER (Regd)		
SUPERVISOR (Regd)		
OWNER (Regd)	MR. BALIRAM SINGH	
DEVELOPMENT AUTHORITY		LOCAL BODY

COLOR INDEX	
PLOT BOUNDARY	Black
ABUTTING ROAD	Green
PROPOSED CONSTRUCTION	Red
COMMON PLOT	Yellow
ROAD WIDENING AREA	Orange
EXISTING (To be retained)	Blue
EXISTING (To be demolished)	Light Blue

Buildingwise Floor FAR Details

Floor Name	Building Name A (RESIDENTIAL)		Total	
	Proposed Built Up Area (Sq.mt.)	Proposed FAR Area (Sq.mt.)	Total Proposed Built Up Area (Sq.mt.)	Total FAR Area (Sq.mt.)
Ground Floor	114.31	36.22	114.31	36.22
First Floor	114.31	114.31	114.31	114.31
Second Floor	114.31	114.31	114.31	114.31
Terrace Floor	0.00	0.00	0.00	0.00
Total :	342.93	264.84	342.93	264.84

Building USE/SUBUSE Details

Building Name	Building Use	Building SubUse	Building Structure
A (RESIDENTIAL)	Residential	Bungalow/ Dwelling / Non Apartment	Non-Highrise

LTP NAME AND SIGNATURE	STRUCTURAL ENG'S NAME AND SIGNATURE	BUILDER NAME AND SIGNATURE	DIGITAL SIGNATURE
Chandrika Sharma MNAC/DFTMN/0017/2017			

Proposal Basic Information	
Proposal File No.	MNAC/BP/0005/W10/2023
Owner Name	MR. BALIRAM SINGH
Khata No	269
Plot No	3730
Village Name	Mango
Use	Residential
SubUse	Bungalow/ Dwelling / Non Apartment

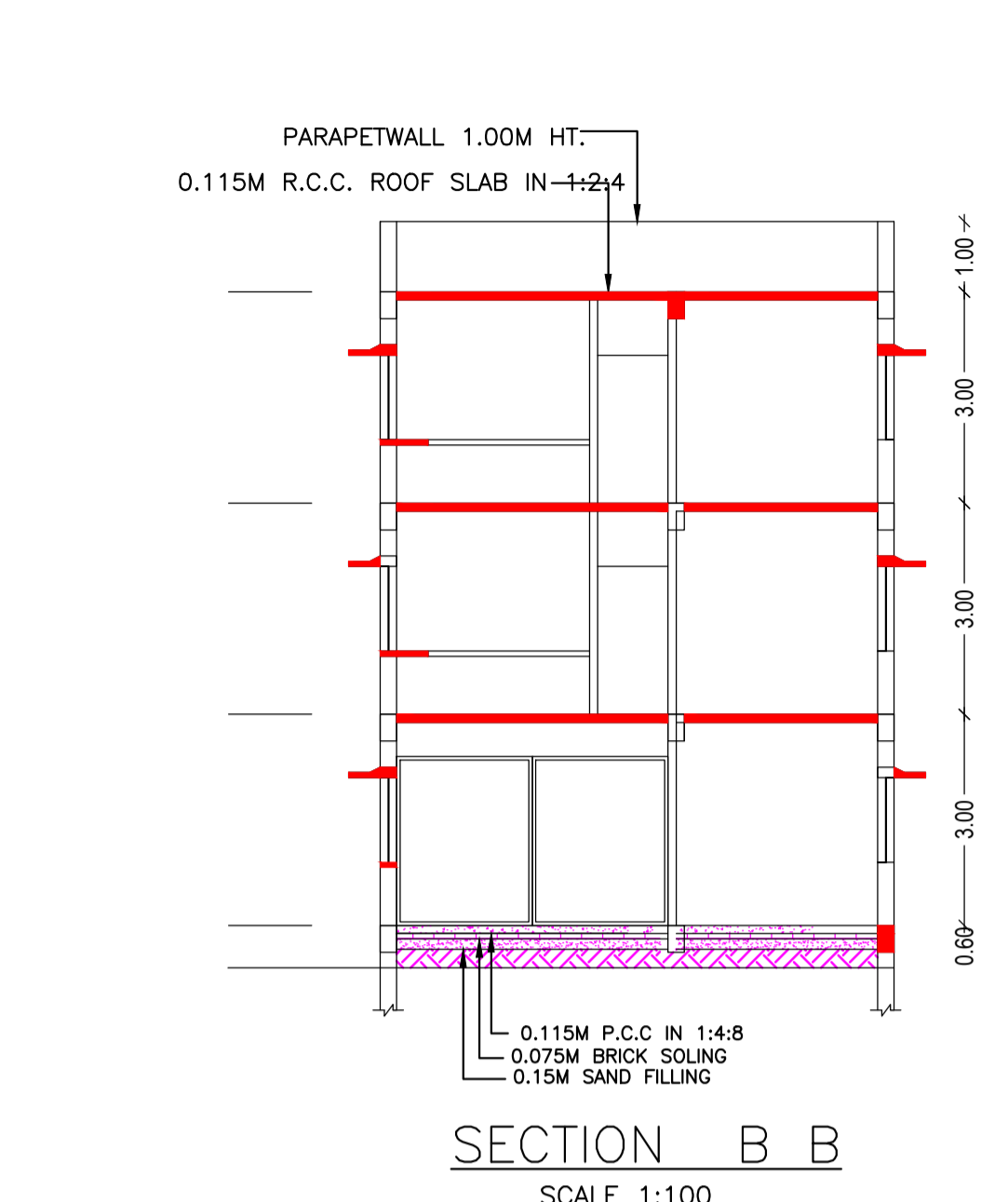
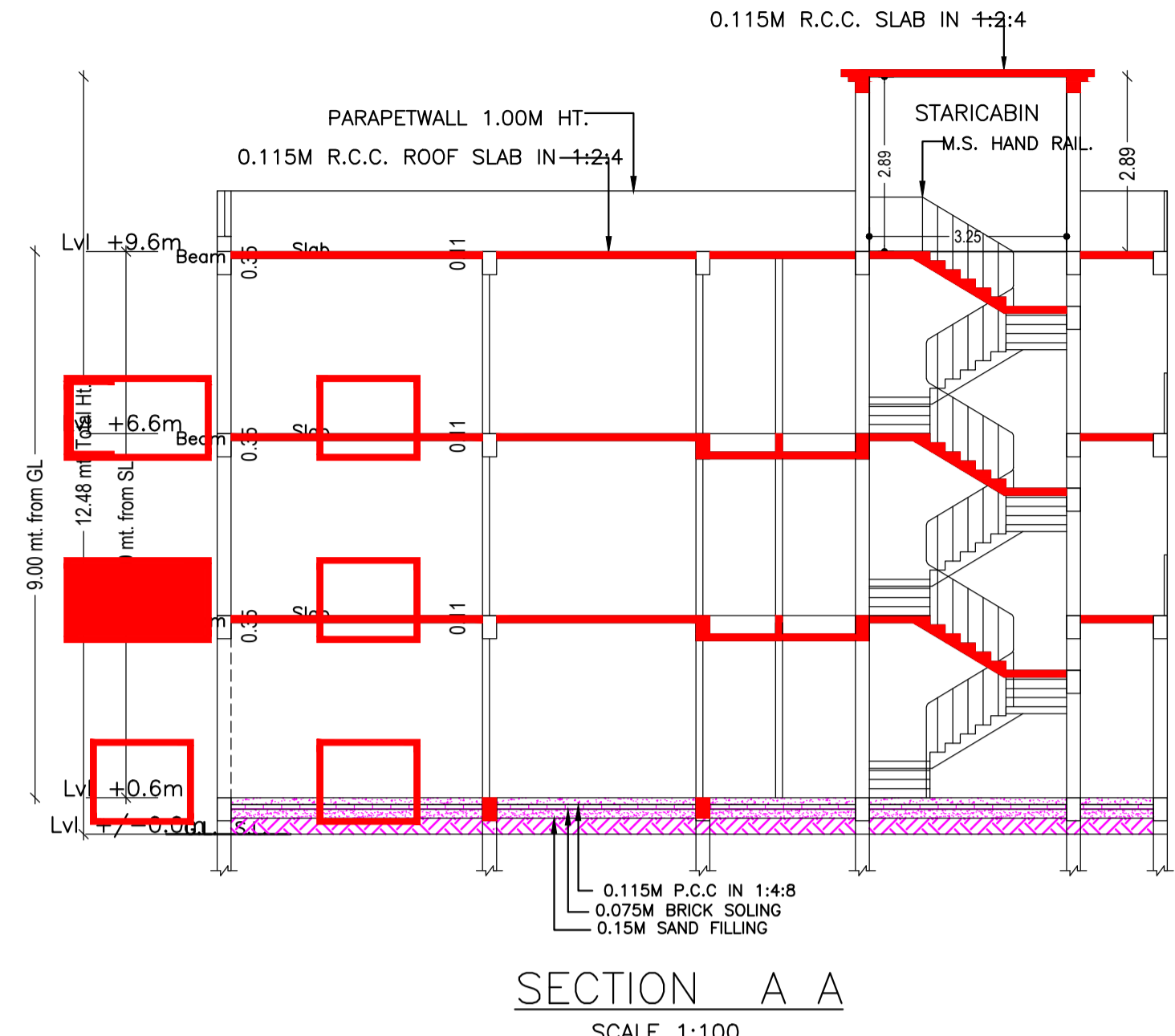
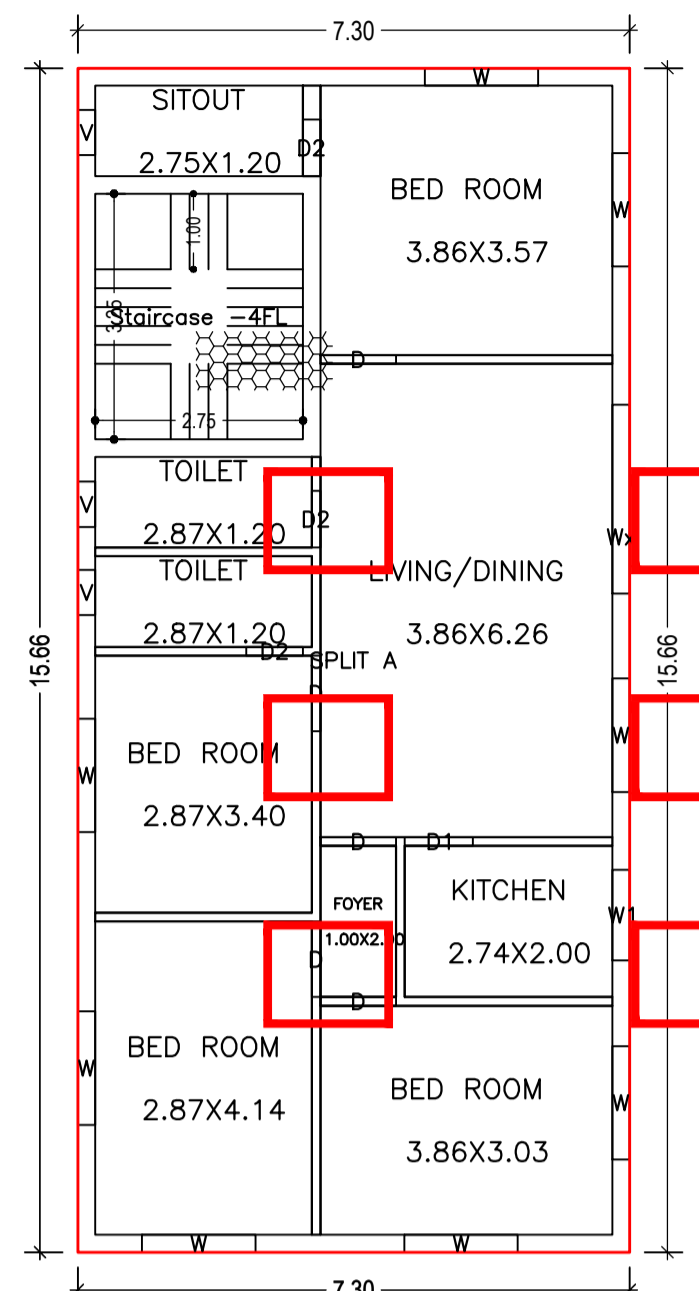
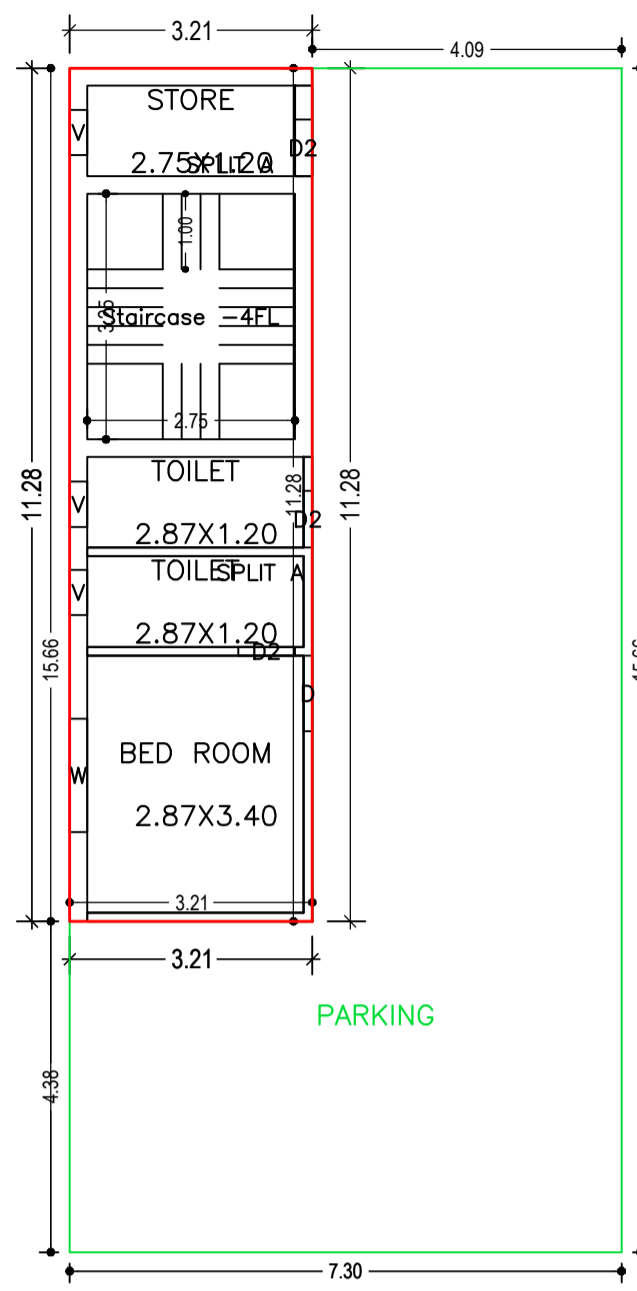

EAST SIDE ELEVATION
SCALE 1:100

GROUND FLOOR PLAN
(Proposed)
SCALE 1:100

TYPICAL - 1 & 2 FLOOR PLAN
(Proposed)
SCALE 1:100

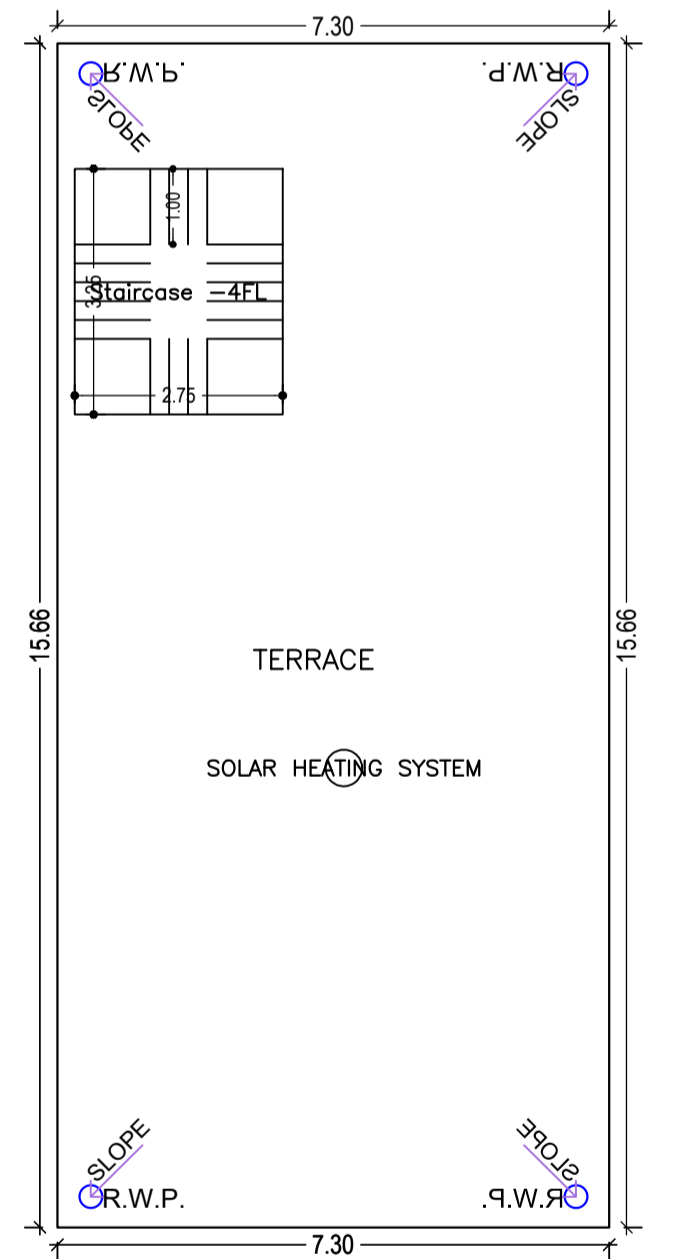

TERRACE FLOOR PLAN
(SCALE 1:100)

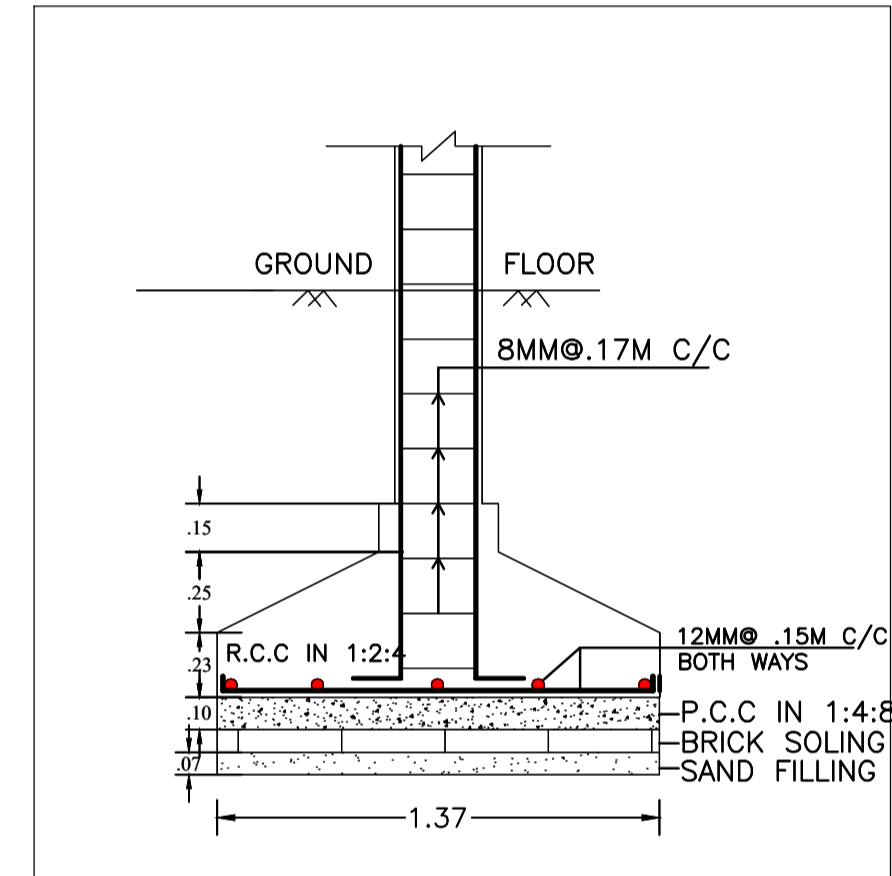

SECTION - CC
SCALE -1:25

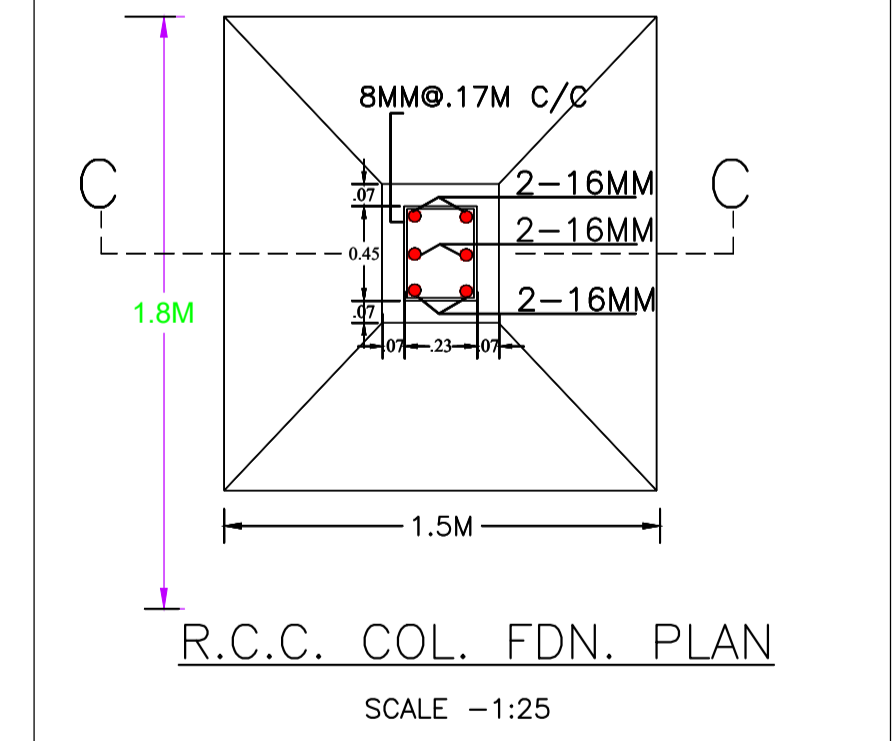

R.C.C. COL. FDN. PLAN
SCALE -1:25

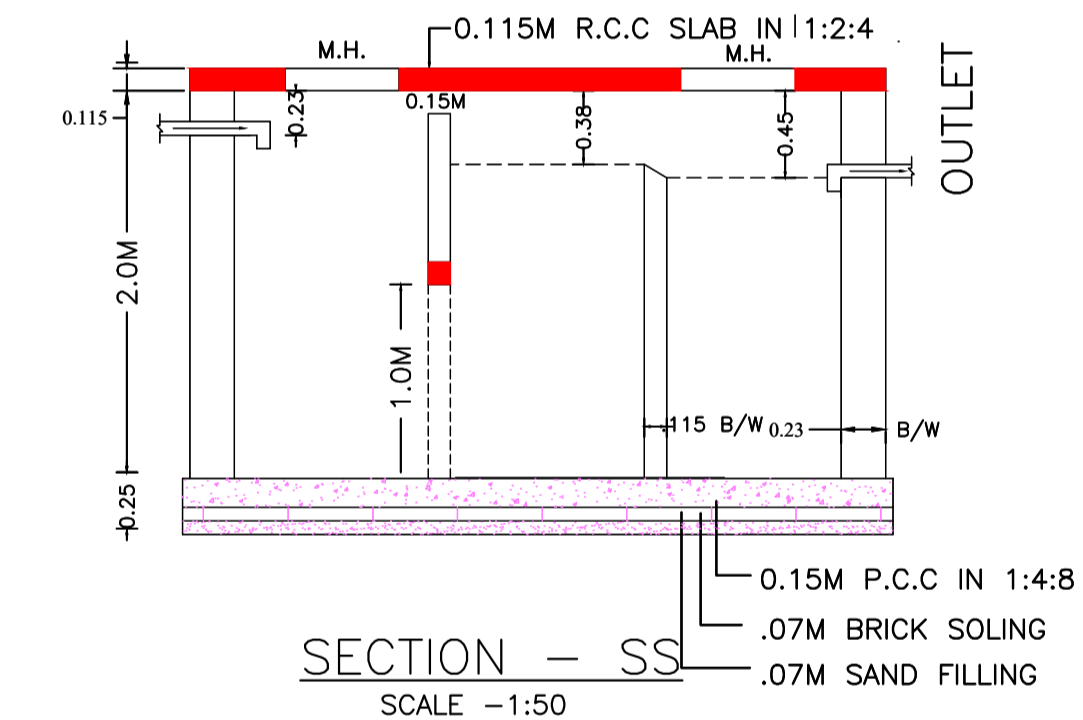

SECTION - SS
SCALE -1:50

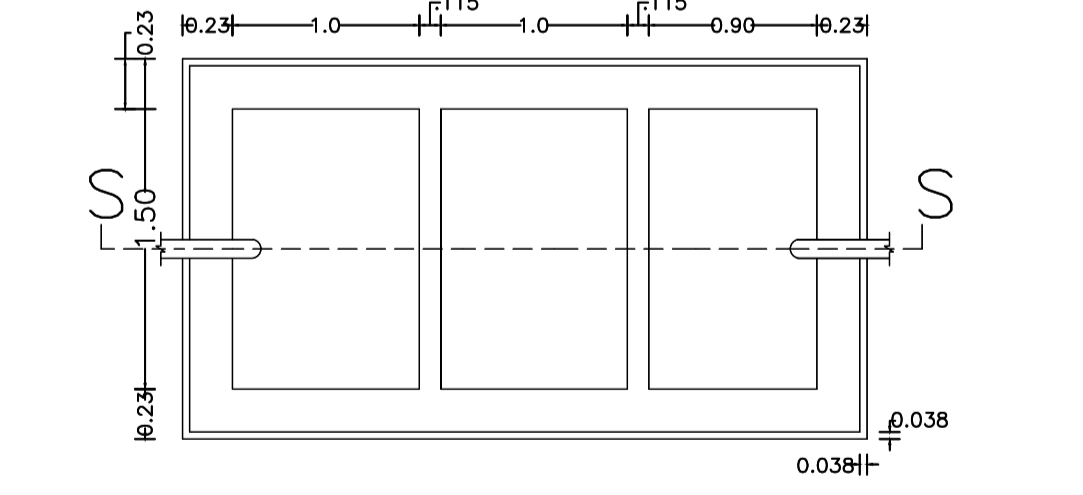

SEPTIC TANK PLAN

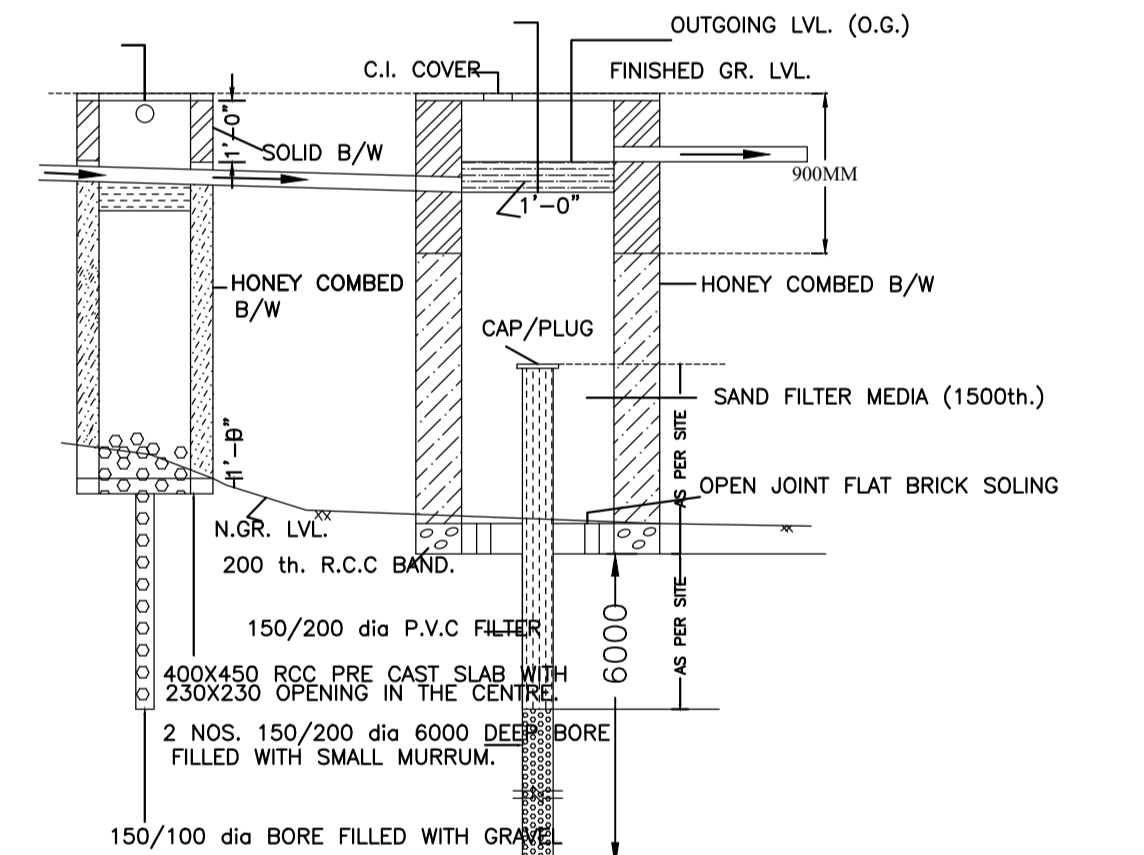

SECTION
WATER HARVESTING PLAN (NTS)

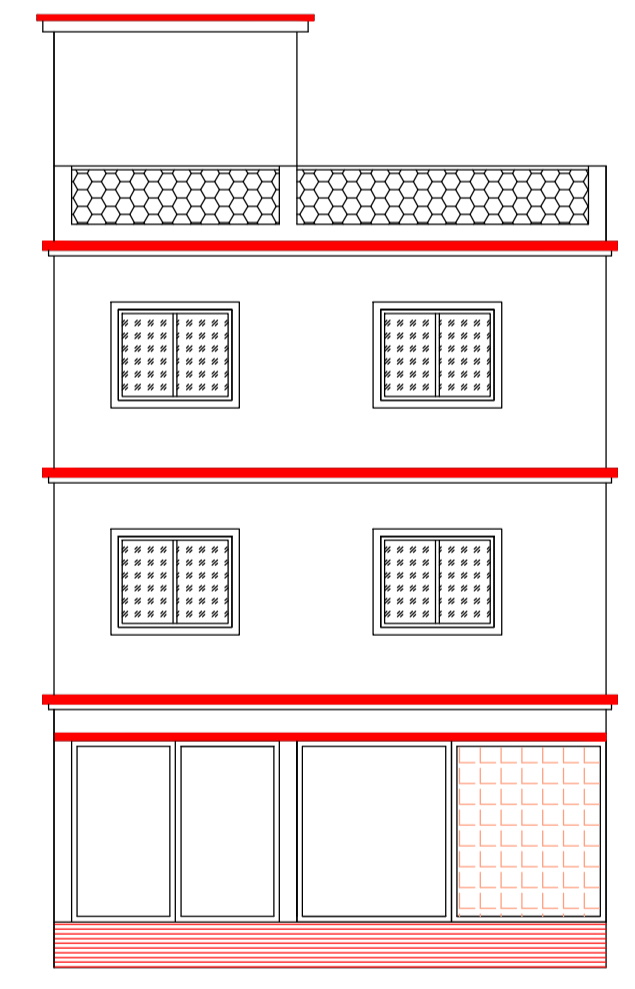

FRONT ELEVATION
SCALE 1:100

Building :A (RESIDENTIAL)

Floor Name	Total Built Up Area (Sq.mt.)	Deductions (Area in Sq.mt.)		Proposed FAR Area (Sq.mt.)	Total FAR Area (Sq.mt.)	Total Consumed Additional FAR Area (Sq.mt.)	Trmt (No.)
		Parking	Resi.				
Ground Floor	114.31	78.09	36.22	36.22	36.22	36.22	01
First Floor	114.31	0.00	114.31	114.31	114.31	114.31	00
Second Floor	114.31	0.00	114.31	114.31	114.31	114.31	00
Terrace Floor	0.00	0.00	0.00	0.00	0.00	0.00	00
Total:	342.93	78.09	264.84	264.84	264.84	264.84	01
Total Number of Same Buildings	1						
Total:	342.93	78.09	264.84	264.84	264.84	264.84	01

SCHEDULE OF DOOR:

BUILDING NAME	NAME	LENGTH	HEIGHT	NOS
A (RESIDENTIAL)	D2	0.75	2.10	09
A (RESIDENTIAL)	D1	0.90	2.10	02
A (RESIDENTIAL)	D	1.00	2.10	11

SCHEDULE OF WINDOW/VENTILATION:

BUILDING NAME	NAME	LENGTH	HEIGHT	NOS
A (RESIDENTIAL)	V	0.60	0.90	09
A (RESIDENTIAL)	W1	1.20	1.20	02
A (RESIDENTIAL)	W	1.50	1.20	17
A (RESIDENTIAL)	Wx	2.50	1.20	02

UnitBUA Table for Building :A (RESIDENTIAL)

FLOOR	Name	UnitBUA Type	UnitBUA Area	Carpet Area	No. of Rooms	No. of Tenement
GROUND FLOOR PLAN	SPLIT A	FLAT	207.71	197.72	1	1
A (RESIDENTIAL)	SPLIT A	FLAT	0.00	0.00	3	3
TYPICAL -1& 2 FLOOR PLAN	SPLIT A	FLAT	0.00	0.00	10	0
Total:	-	-	207.71	197.72	24	1

LTP NAME AND SIGNATURE	STRUCTURAL ENG'S NAME AND SIGNATURE	BUILDER NAME AND SIGNATURE	DIGITAL SIGNATURE
Chandrika Sharma MNAC/DFTMN/0017/2017			

Proposal Basic Information	
Proposal File No.	MNAC/BP/0005/W10/2023
Owner Name	MR. BALIRAM SINGH
Khata No	269
Plot No	3730
Village Name	Mango
Use	Residential
SubUse	Bungalow/ Dwelling / Non Apartment

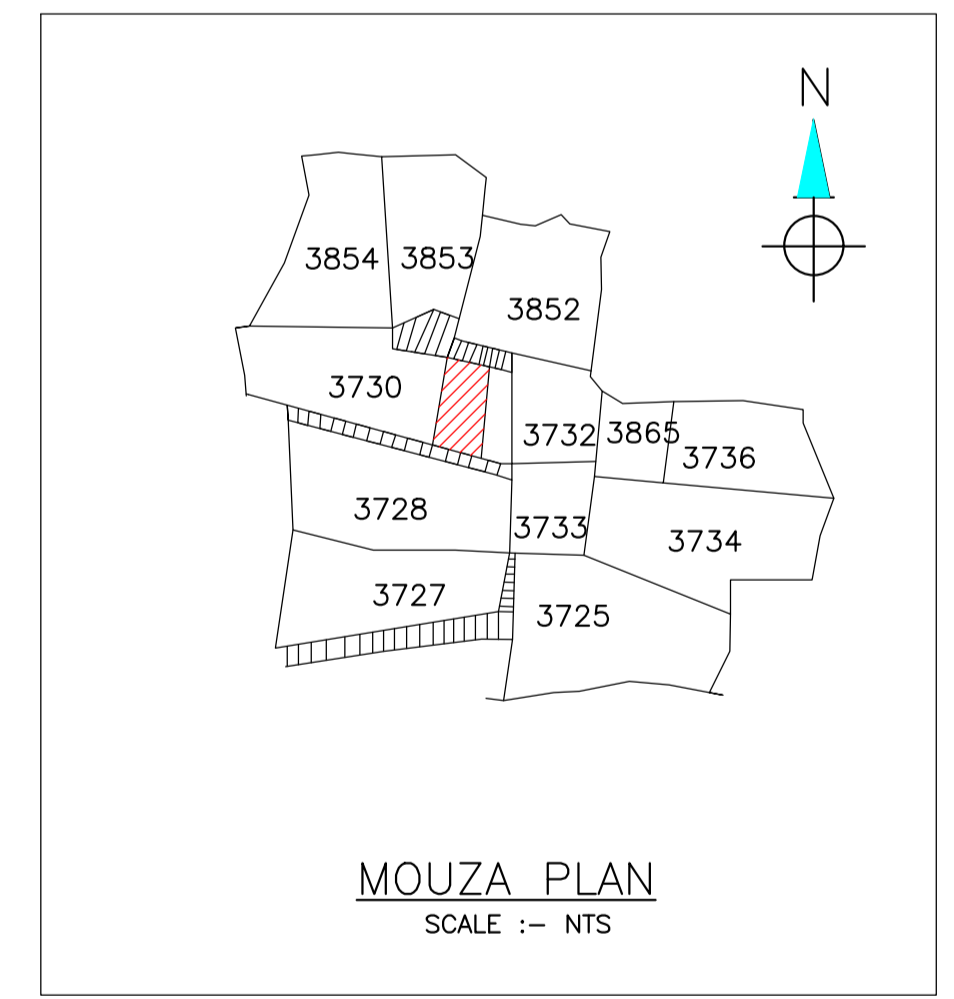
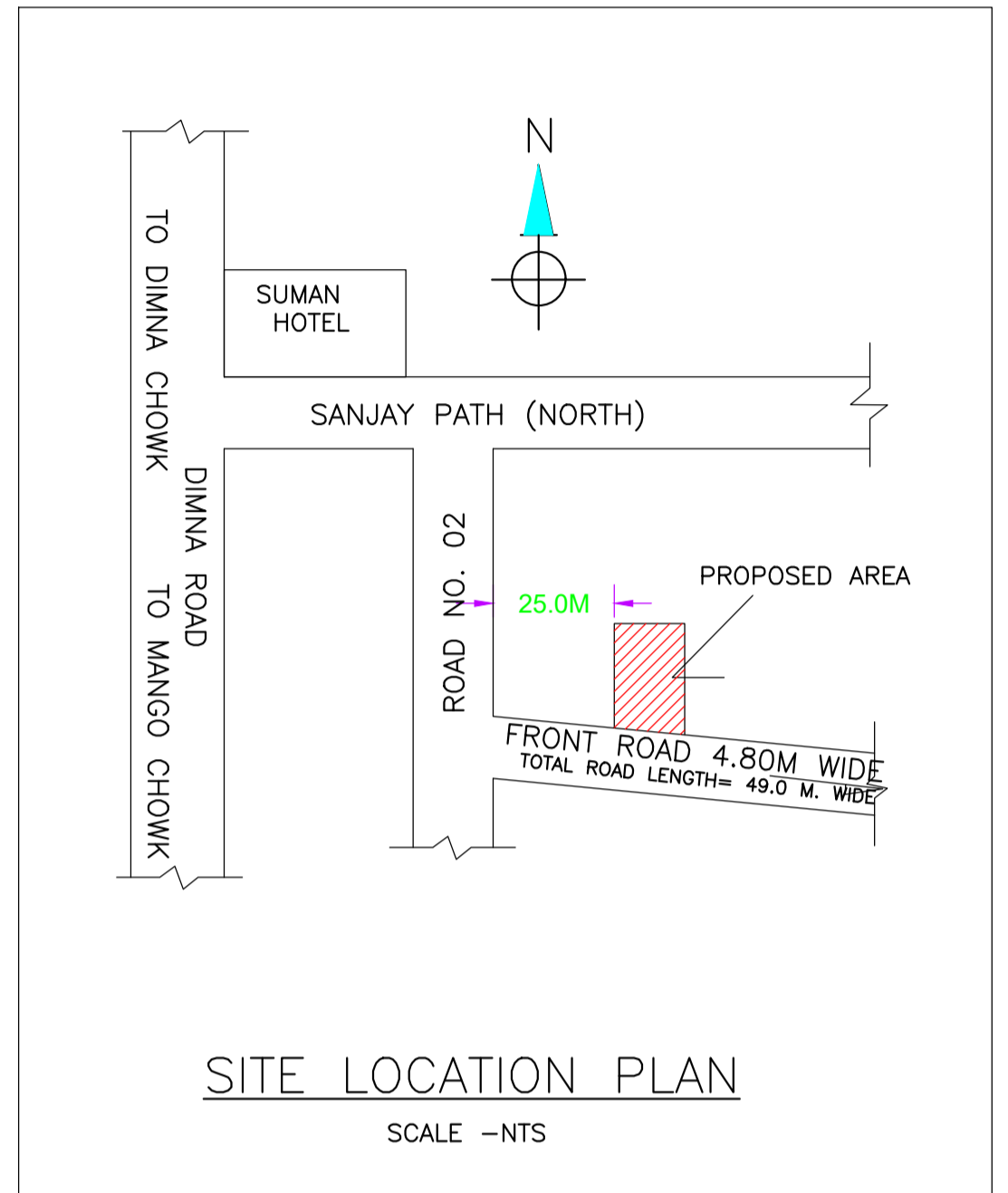

LTP NAME AND SIGNATURE	STRUCTURAL ENG'S NAME AND SIGNATURE	BUILDER NAME AND SIGNATURE	DIGITAL SIGNATURE
Chandrika Sharma MNAC/DFTMN/0017/2017			