

SITE PLAN

FAR & Tenement Details (Table 4c-1)

Building	No. of Same Bldg	Total Built Up Area (Sq.mt.)	Deductions (Area in Sq.mt.)		Proposed FAR Area (Sq.mt.)	Add Area In FAR (Sq.mt.)	Total FAR Area (Sq.mt.)	Total Consumed Additional FAR Area (Sq.mt.)	Trmnt (No.)
			Parking	Resi.					
A (SHAMSHER ALAM)	1	225.03	62.03	153.58	9.42	163.00	163.00	01	
Grand Total :	1	225.03	62.03	153.58	9.42	163.00	163.00	01	

Proposal Basic Information

Proposal File No.	MNAC/BP/0046/W08/2023
Owner Name	MR.SHAMSHER ALAM
Khata No	644
Plot No	3426
Village Name	Mango
Use	Residential
SubUse	Bungalow/ Dwelling / Non Apartment

AREA STATEMENT MANGO MUNICIPAL CORPORATION	VERSION NO. : 1.0.68
	VERSION DATE: 16/10/2020
PROJECT DETAIL:	
Region: JHARKHAND URBAN LOCAL BODIES	Plot Use: Residential
District: EAST SINGHBHUM	Plot SubUse: Bungalow/ Dwelling / Non Apartment
Authority: MANGO MUNICIPAL CORPORATION	PlotNearbyReligiousStructure: NA
Inward No: MNAC/BP/0046/W08/2023	PlotSubPlot No: 3426
Application Type: General Proposal	North: -
Project Type: Building Permission	South: -
Nature of Development: New	East: -
Location of Development Area: Old Area	West: -
AREA DETAILS:	
AREA OF PLOT (Minimum)	(A)
NET AREA OF PLOT(Gross Plot Area - Deduction from Gross Plot area)	(A-Deductions)
Deduction for Balance Plot Area(from Gross Plot Area)	
Common Plot	13.55
Total	13.55
BALANCE AREA OF PLOT(Net Plot Area - Recreational/Amenity space)	(A-Deductions)
PLOT AREA FOR COVERAGE(Net Plot Area)	(A-Deductions)
Plot Area for FAR (Net Plot Area + RoadWidening Area)	(A-Deductions)
COVERAGE CHECK	
Permissible Coverage area (70.00 %)	84.04
Proposed Coverage Area (59.51 %)	71.45
Total Prop. Coverage Area (59.51 %)	71.45
Balance coverage area (10.49 %)	12.59
FAR CHECK	
Perm. FAR Area (1.800)	216.11
Total Perm. FAR area	216.11
Residential FAR	153.59
Proposed FAR Area	163.01
Total Proposed FAR Area	163.01
Consumed FAR (Factor)	1.36
Balance FAR Area	53.10
BUILT UP AREA CHECK	
Total Proposed BuiltUp Area	225.03
ARCHITECT (Regd)	MOHAMMAD BELAL NASIR
ENGINEER (Regd)	
SUPERVISOR (Regd)	
OWNER (Regd)	MR.SHAMSHER ALAM
DEVELOPMENT AUTHORITY	LOCAL BODY

COLOR INDEX	
PLOT BOUNDARY	Black
ABUTTING ROAD	Green
PROPOSED CONSTRUCTION	Red
COMMON PLOT	Yellow
ROAD WIDENING AREA	Orange
EXISTING (To be retained)	Blue
EXISTING (To be demolished)	Light Blue

Buildingwise Floor FAR Details

Floor Name	Building Name A (SHAMSHER ALAM)		Total	
	Proposed Built Up Area (Sq.mt.)	Proposed FAR Area (Sq.mt.)	Total Proposed Built Up Area (Sq.mt.)	Total FAR Area (Sq.mt.)
Ground Floor	71.45	9.42	71.45	9.42
First Floor	76.79	76.79	76.79	76.79
Second Floor	76.79	76.79	76.79	76.79
Terrace Floor	0.00	0.00	0.00	0.00
Total :	225.03	163.00	225.03	163.00

Building USE/SUBUSE Details

Building Name	Building Use	Building SubUse	Building Structure
A (SHAMSHER ALAM)	Residential	Residential Bldg/Apartment	Non-Highrise

LTP NAME AND SIGNATURE	STRUCTURAL ENG'S NAME AND SIGNATURE	BUILDER NAME AND SIGNATURE	DIGITAL SIGNATURE
MOHAMMAD BELAL NASIR MNAC/ENG/0007/2016			

Proposal Basic Information

Proposal File No.	MNAC/BP/0046/W08/2023
Owner Name	MR.SHAMSHER ALAM
Khata No	644
Plot No	3426
Village Name	Mango
Use	Residential
SubUse	Bungalow/ Dwelling / Non Apartment

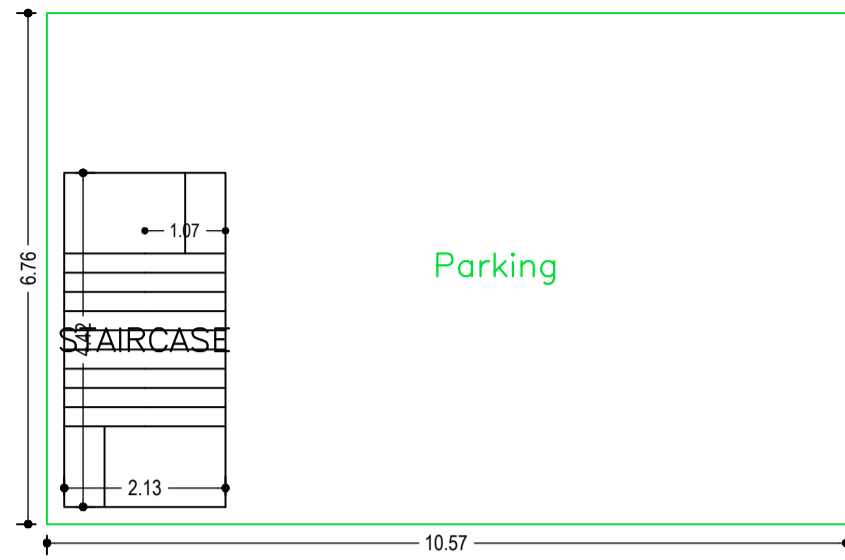

GROUND FLOOR PLAN (SCALE 1:100)

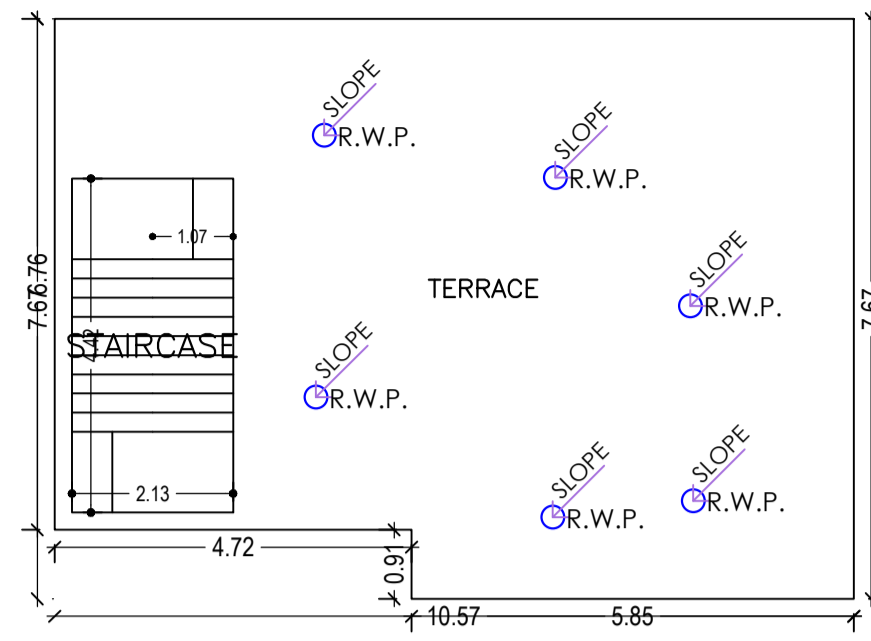

TERRACE FLOOR PLAN (SCALE 1:100)

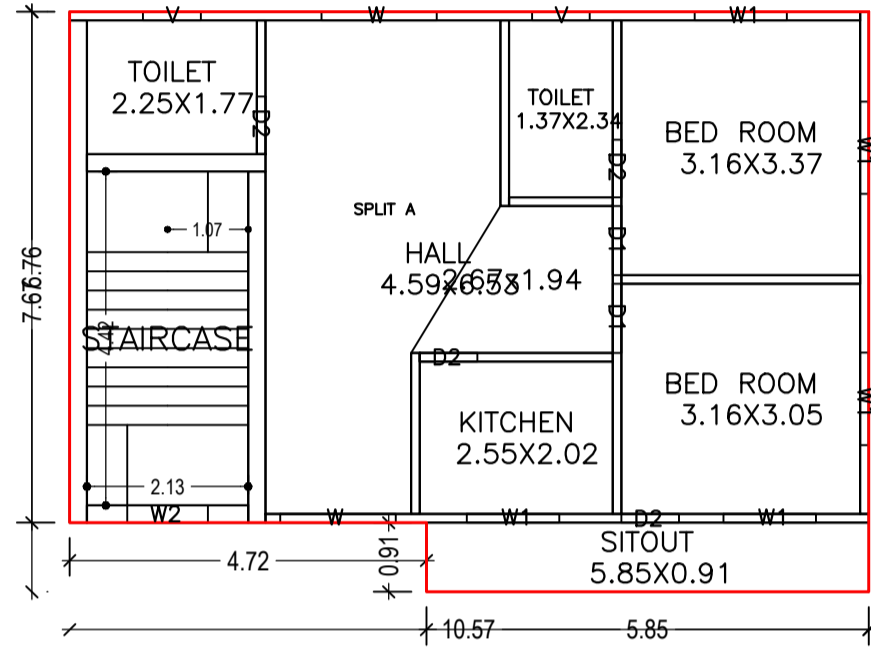

FIRST FLOOR PLAN (Proposed) (SCALE 1:100)

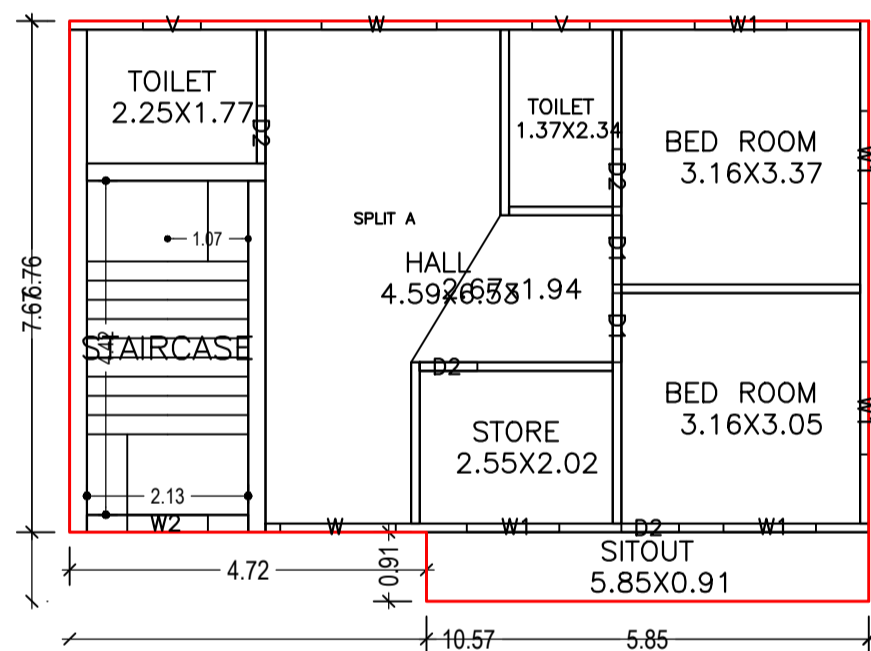

SECOND FLOOR PLAN (Proposed) (SCALE 1:100)

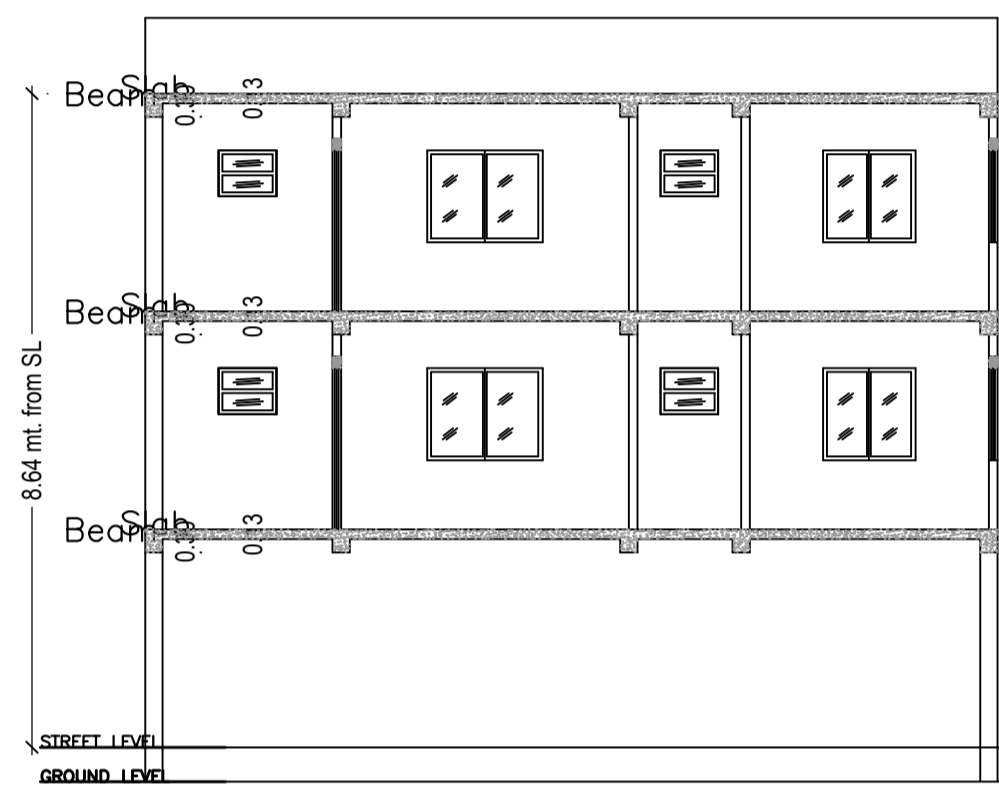

SECTION

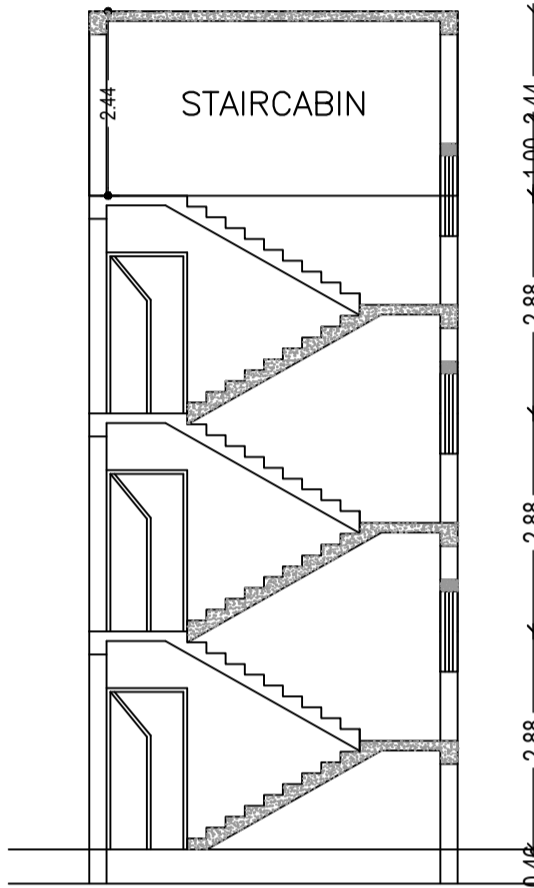

STAIR SECTION

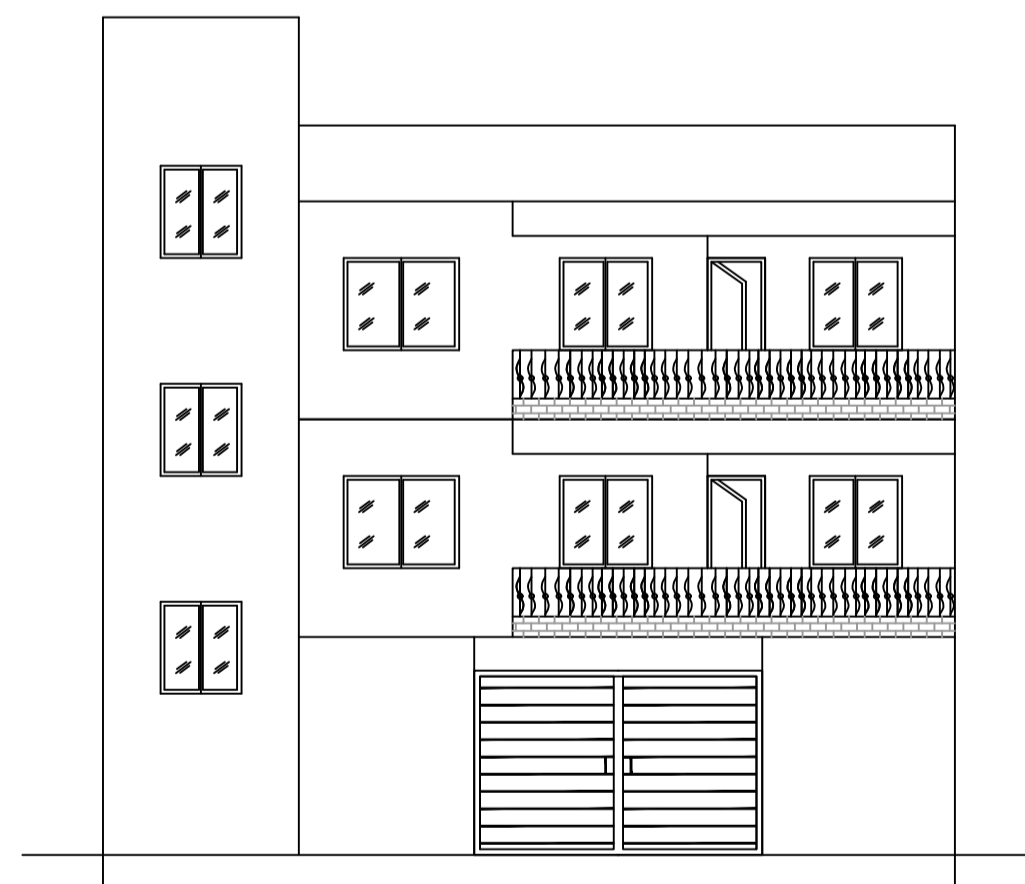

FRONT ELEVATION

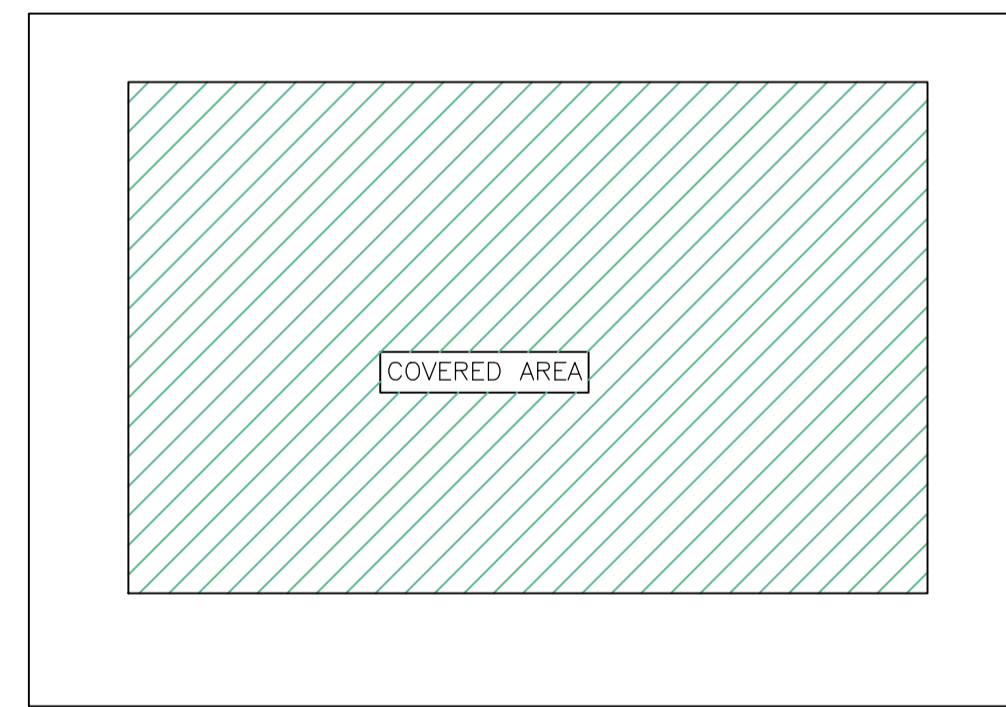

KEY PLAN

SCHEDULE OF DOOR:

BUILDING NAME	NAME	LENGTH	HEIGHT	NOS
A (SHAMSHER ALAM)	D2	0.76	2.10	08
A (SHAMSHER ALAM)	D1	0.91	2.10	04

SCHEDULE OF WINDOW/VENTILATION:

BUILDING NAME	NAME	LENGTH	HEIGHT	NOS
A (SHAMSHER ALAM)	V	0.76	1.20	04
A (SHAMSHER ALAM)	W2	1.06	1.20	02
A (SHAMSHER ALAM)	W1	1.22	1.20	10
A (SHAMSHER ALAM)	W	1.53	1.20	04

UnitBUA Table for Building :A (SHAMSHER ALAM)

FLOOR	Name	UnitBUA Type	UnitBUA Area	Carpet Area	No. of Rooms	No. of Tenement
SECOND FLOOR PLAN	SPLIT A	FLAT	0.00	0.00	7	0
FIRST FLOOR PLAN	SPLIT A	FLAT	153.59	136.08	7	1
Total:	-	-	153.59	136.08	14	1

Building :A (SHAMSHER ALAM)

Floor Name	Total Built Up Area (Sq.mt.)	Deductions (Area in Sq.mt.)	Proposed FAR Area (Sq.mt.)	Add Area In FAR (Sq.mt.)	Total FAR Area (Sq.mt.)	Total Consumed Additional FAR Area (Sq.mt.)	Trmt (No.)
Ground Floor	71.45	62.03	0.00	9.42	9.42	9.42	00
First Floor	76.79	0.00	76.79	0.00	76.79	76.79	01
Second Floor	76.79	0.00	76.79	0.00	76.79	76.79	00
Terrace Floor	0.00	0.00	0.00	0.00	0.00	0.00	00
Total :	225.03	62.03	153.58	9.42	163.00	163.00	01
Total Number of Same Buildings	1						
Total :	225.03	62.03	153.58	9.42	163.00	163.00	01

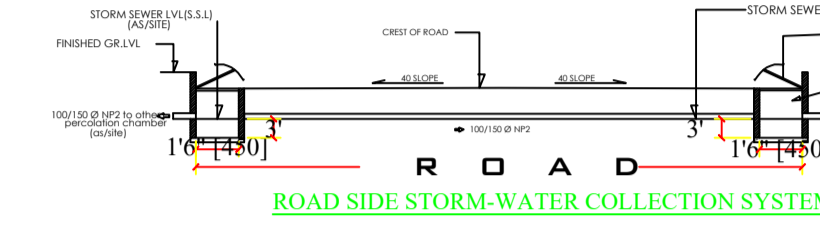

ROAD SIDE STORM-WATER COLLECTION SYSTEM

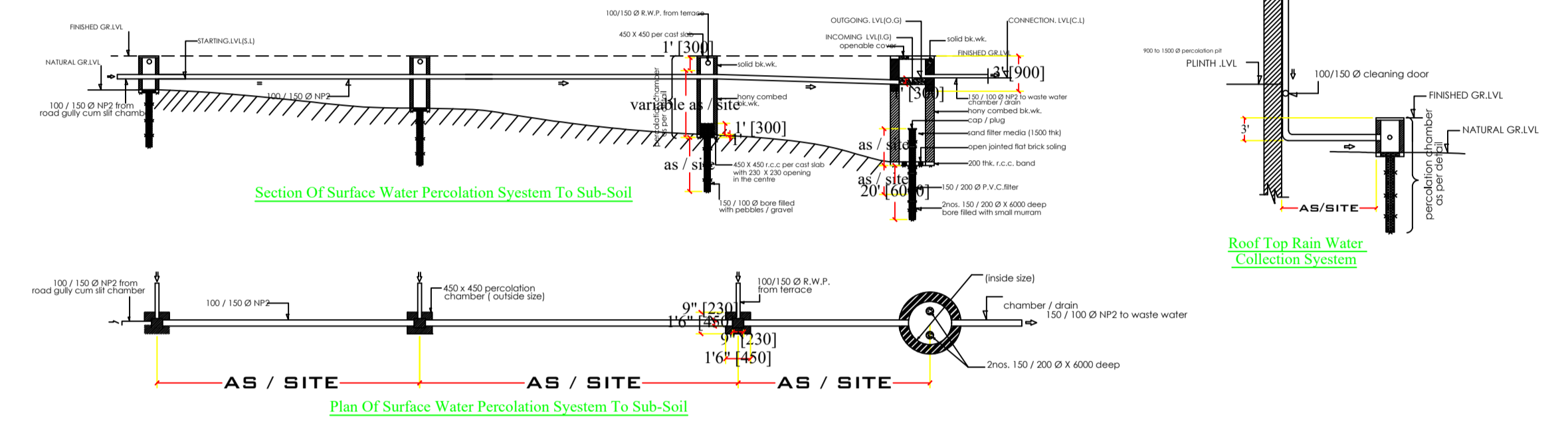

Section Of Surface Water Percolation System To Sub-Soil

Plan Of Surface Water Percolation System To Sub-Soil

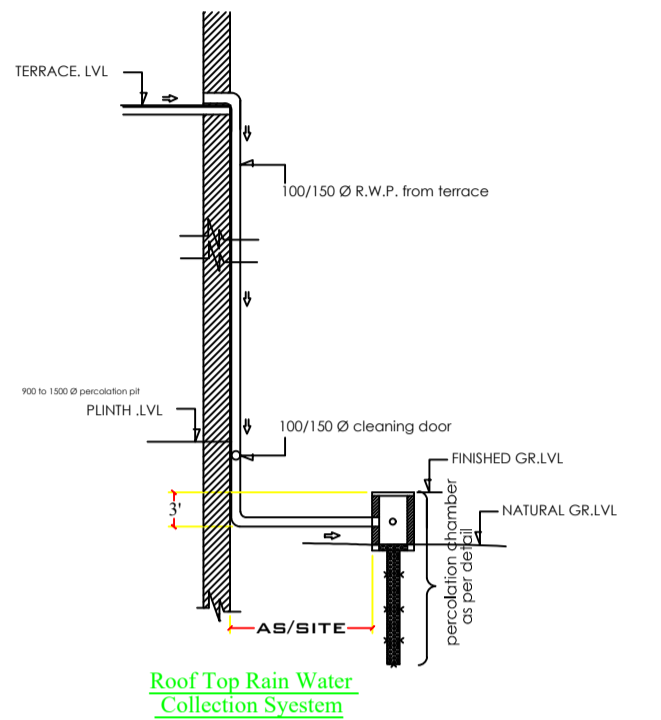

Roof Top Rain Water Collection System

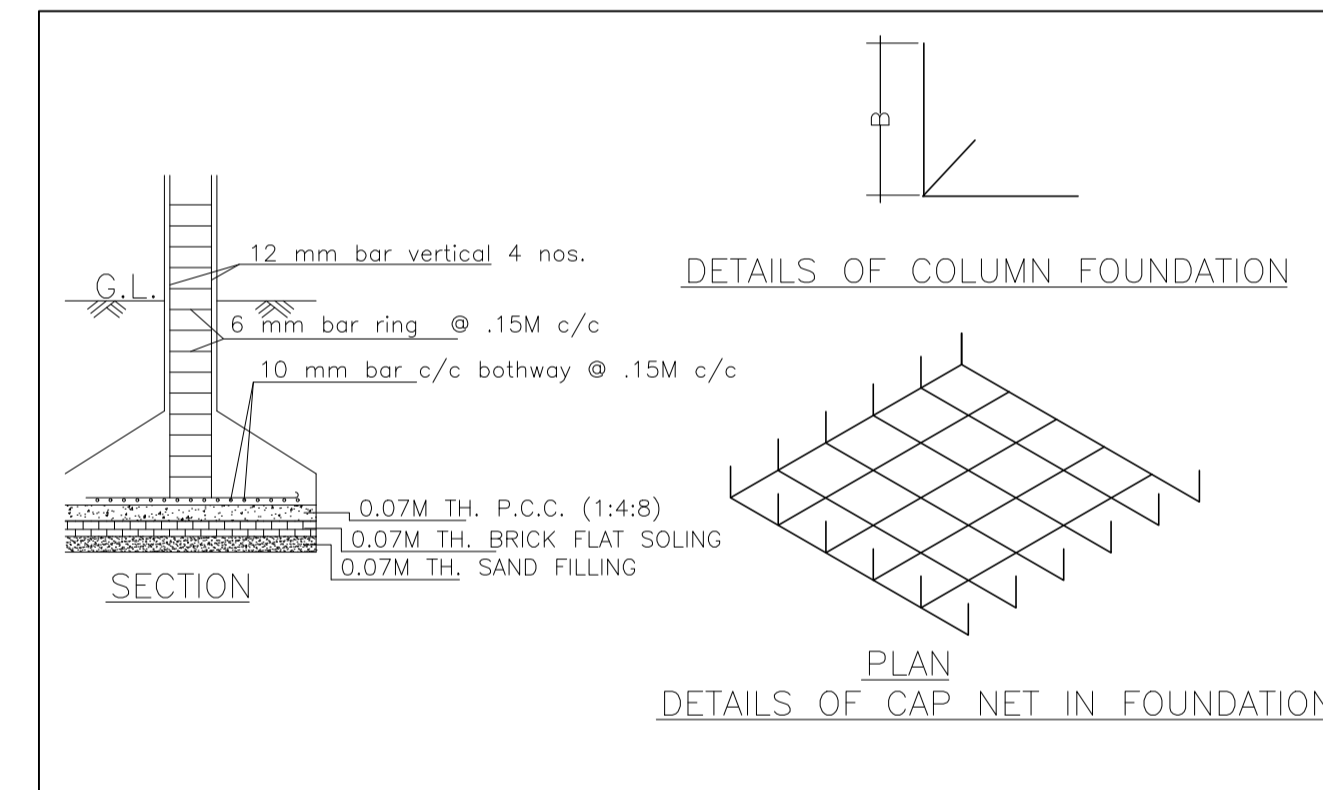

DETAILS OF COLUMN FOUNDATION

DETAILS OF CAP NET IN FOUNDATION

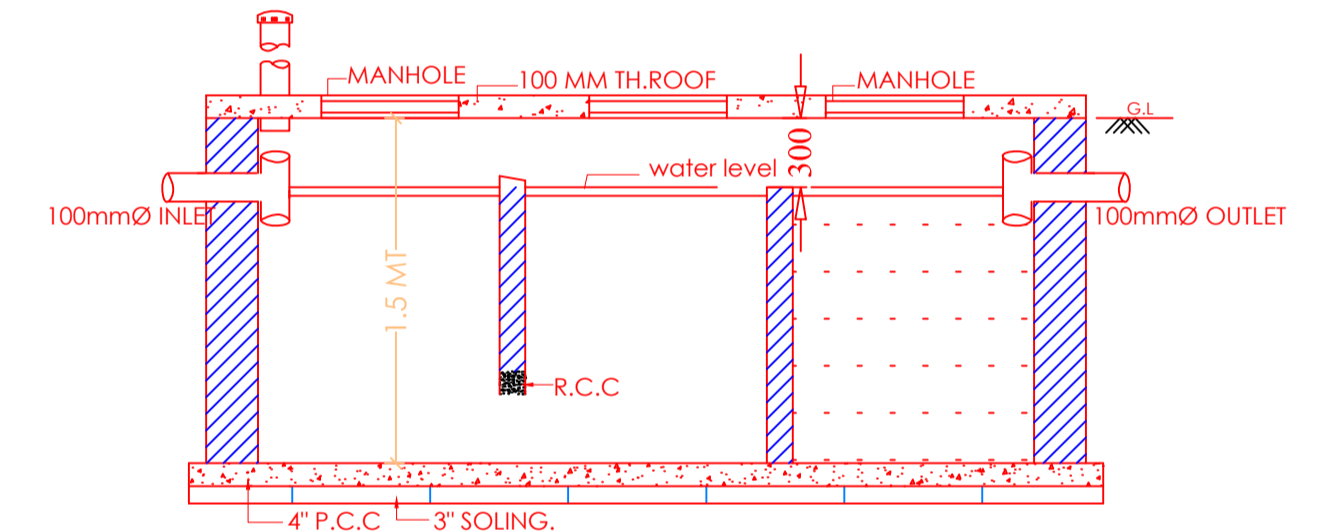

SECTION OF SEPTIC TANK.

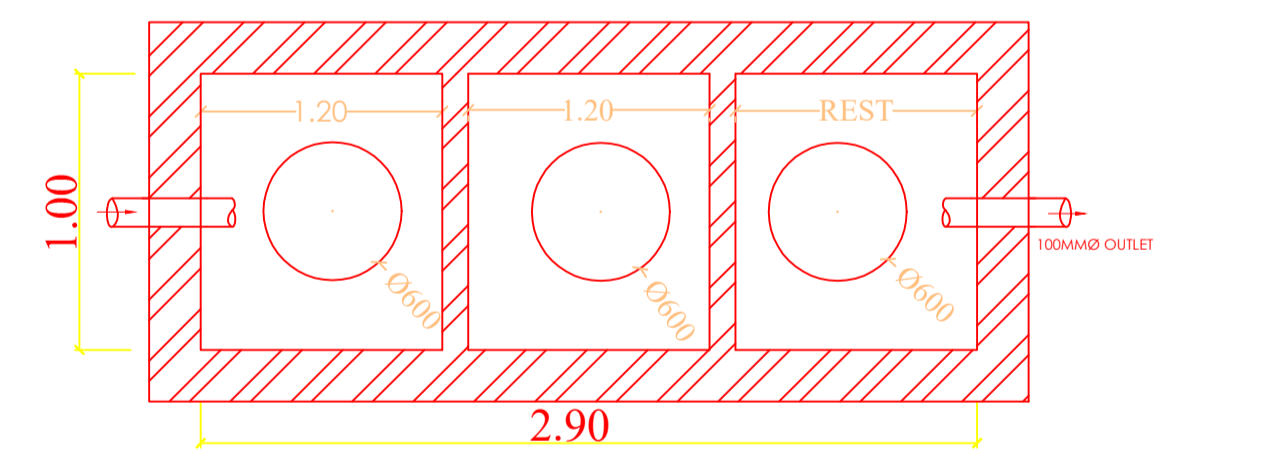

PLAN OF SEPTIC TANK

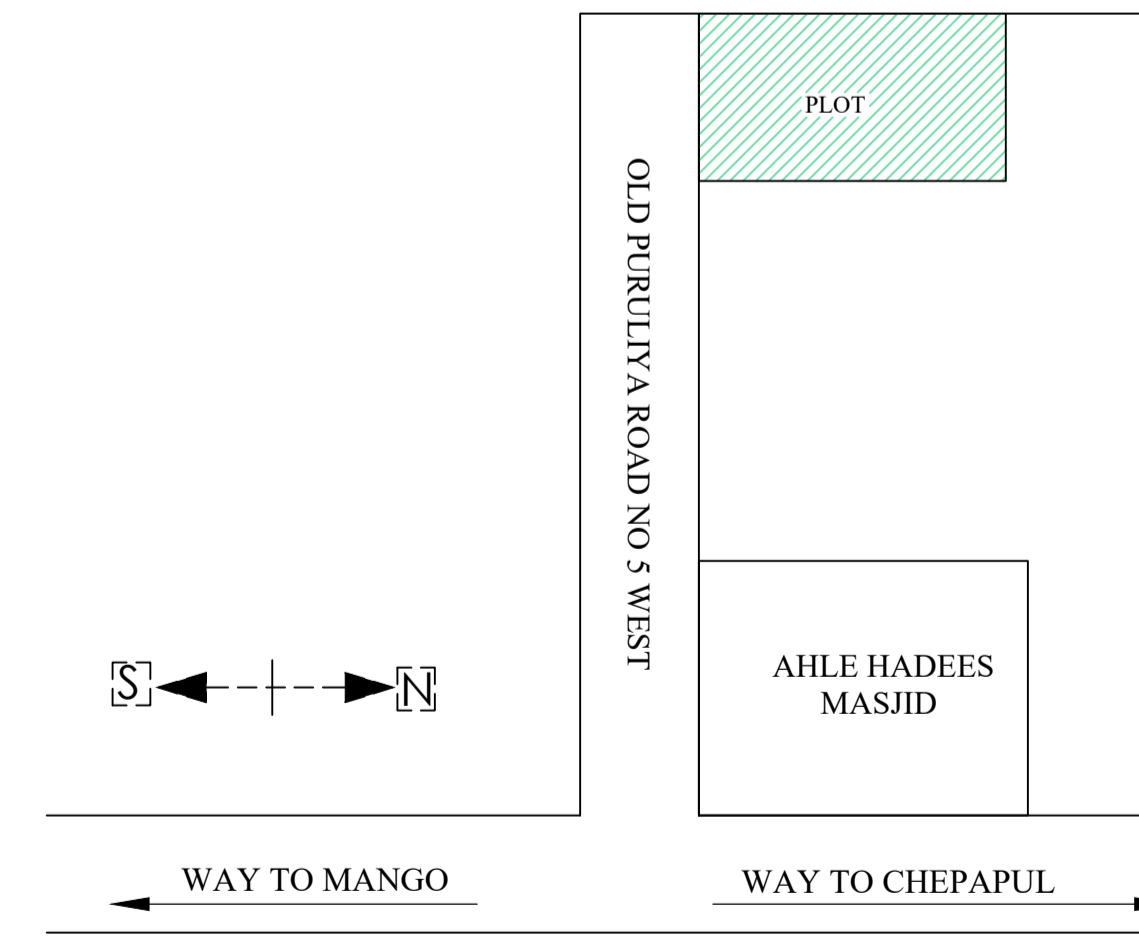

Proposal Basic Information	
Proposal File No.	MNAC/BP/0046/W08/2023
Owner Name	MR.SHAMSHER ALAM
Khata No	644
Plot No	3426
Village Name	Mango
Use	Residential
SubUse	Bungalow/ Dwelling / Non Apartment

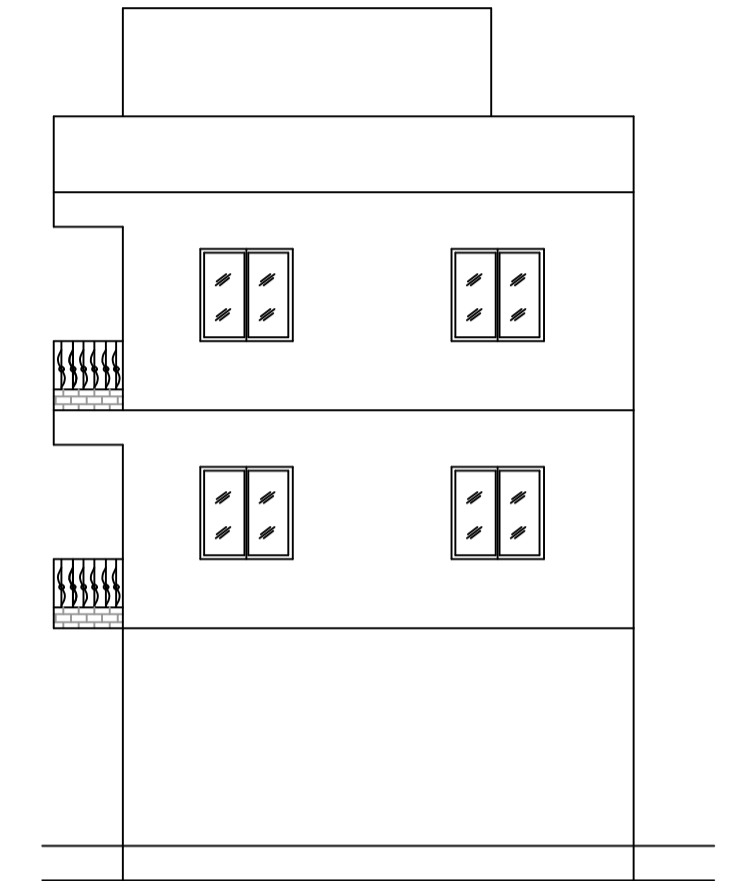

SIDE ELEVATION

LTP NAME AND SIGNATURE	STRUCTURAL ENG'S NAME AND SIGNATURE	BUILDER NAME AND SIGNATURE	DIGITAL SIGNATURE
MOHAMMAD BELAL NASIR MNAC/ENG/0007/2016			