

SITE - PLAN
SCALE 1:100

SITE PLAN

FAR & Tenement Details (Table 4c-1)

Building	No. of Same Bldg	Total Built Up Area (Sq.mt.)	Deductions (Area in Sq.mt.)		Proposed FAR Area (Sq.mt.)	Add Area In FAR (Sq.mt.)	Total FAR Area (Sq.mt.)	Total Consumed Additional FAR Area (Sq.mt.)	Trnmt (No.)
			Lift	Parking					
A (RESIDENTIAL)	1	423.40	9.69	93.68	307.86	8.94	320.03	320.03	03
Grand Total	1	423.40	9.69	93.68	307.86	8.94	320.03	320.03	03

Proposal Basic Information

Proposal File No.	MNAC/BP/0053/W09/2023
Owner Name	MRS. MEERA PANDEY
Khata No	131
Plot No	376
Village Name	Pardih
Use	Residential
SubUse	Bungalow/ Dwelling / Non Apartment

Required Parking (Table 7a)

Building Name	Type	SubUse	Area (Sq.mt.)	Units		Car		Visitors Car		TwoWheeler		
				Regd.	Prop.	Regd./Unit	Prop.	Regd./Unit	Prop.	Regd./Unit	Prop.	
A (RESIDENTIAL)	Residential	Bungalow/ Dwelling / Non Apartment	> 0	1	3.00	1.00	3	-	-	-	-	
				> 0	1	3.00	-	-	1	1	-	-
Total :			-	-	-	3	3	-	1	1	0	3

Parking Check (Table 7b)

Vehicle Type	Reqd.		Prop.	
	No.	Area	No.	Area
Car	-	-	3	37.50
Total Car	3	37.50	3	37.50
Visitor's Car Parking	-	-	1	12.50
Total Visitor Parking	1	12.50	1	12.50
TwoWheeler	-	-	3	6.00
Total TwoWheeler	-	-	3	6.00
Other Parking	-	-	-	56.18
Total	-	50.00	-	118.18

AREA STATEMENT MANGO MUNICIPAL CORPORATION	VERSION NO: 1.0.66	
	VERSION DATE: 16/10/2020	
PROJECT DETAIL:		
Region: JHARKHAND URBAN LOCAL BODIES	Plot Use: Residential	
District: EAST SINGBHUM	Plot SubUse: Bungalow/ Dwelling / Non Apartment	
Authority: MANGO MUNICIPAL CORPORATION	PlotNearbyReligiousStructure: NA	
Inward No: MNAC/BP/0053/W09/2023	Plot/SubPlot No: 376	
Application Type: General Proposal	North: -	
Project Type: Building Permission	South: -	
Nature of Development: New	East: -	
Location of Development Area: Old Area	West: -	
AREA DETAILS:		
AREA OF PLOT (Minimum)	(A)	SQ.MT. 178.83
NET AREA OF PLOT(Gross Plot Area - Deduction from Gross Plot area)	(A-Deductions)	178.83
Deduction for Balance Plot Area(from Gross Plot Area)		
Common Plot		30.09
Total		30.09
BALANCE AREA OF PLOT(Net Plot Area - Recreational/Amenity space)	(A-Deductions)	148.74
PLOT AREA FOR COVERAGE(Net Plot Area)	(A-Deductions)	178.83
Plot Area for FAR (Net Plot Area + RoadWidening Area)	(A-Deductions)	178.83
COVERAGE CHECK		
Permissible Coverage area (60.00 %)		107.30
Proposed Coverage Area (59.19 %)		105.85
Total Prop. Coverage Area (59.19 %)		105.85
Balance coverage area (0.81 %)		1.45
FAR CHECK		
Perm. FAR Area (2.500)		447.08
Total Perm. FAR area		447.08
Residential FAR		307.85
Proposed FAR Area		320.02
Total Proposed FAR Area		320.02
Consumed FAR (Factor)		1.79
Balance FAR Area		127.06
BUILT UP AREA CHECK		
Total Proposed BuiltUp Area		423.40
ARCHITECT (Regd)	EJAZ AHMAD	
ENGINEER (Regd)		
SUPERVISOR (Regd)		
OWNER (Regd)	MRS. MEERA PANDEY	
DEVELOPMENT AUTHORITY		LOCAL BODY

COLOR INDEX	
PLOT BOUNDARY	Black
ABUTTING ROAD	Green
PROPOSED CONSTRUCTION	Red
COMMON PLOT	Yellow
ROAD WIDENING AREA	Orange
EXISTING (To be retained)	Blue
EXISTING (To be demolished)	Light Blue

Buildingwise Floor FAR Details

Floor Name	Building Name A (RESIDENTIAL)		Total	
	Proposed Built Up Area (Sq.mt.)	Proposed FAR Area (Sq.mt.)	Total Proposed Built Up Area (Sq.mt.)	Total FAR Area (Sq.mt.)
Ground Floor	105.85	12.17	105.85	12.17
First Floor	105.85	102.62	105.85	102.62
Second Floor	105.85	102.62	105.85	102.62
Third Floor	105.85	102.62	105.85	102.62
Terrace Floor	0.00	0.00	0.00	0.00
Total	423.40	320.03	423.40	320.03

Building USE/SUBUSE Details

Building Name	Building Use	Building SubUse	Building Structure
A (RESIDENTIAL)	Residential	Bungalow/ Dwelling / Non Apartment	Non-Highrise

LTP NAME AND SIGNATURE	STRUCTURAL ENG'S NAME AND SIGNATURE	BUILDER NAME AND SIGNATURE	DIGITAL SIGNATURE
EJAZ AHMAD MNAC/DFTMN/0008/2020			

Proposal Basic Information	
Proposal File No.	MNAC/BP/0053/W09/2023
Owner Name	MRS. MEERA PANDEY
Khata No	131
Plot No	376
Village Name	Pardih
Use	Residential
SubUse	Bungalow/ Dwelling / Non Apartment

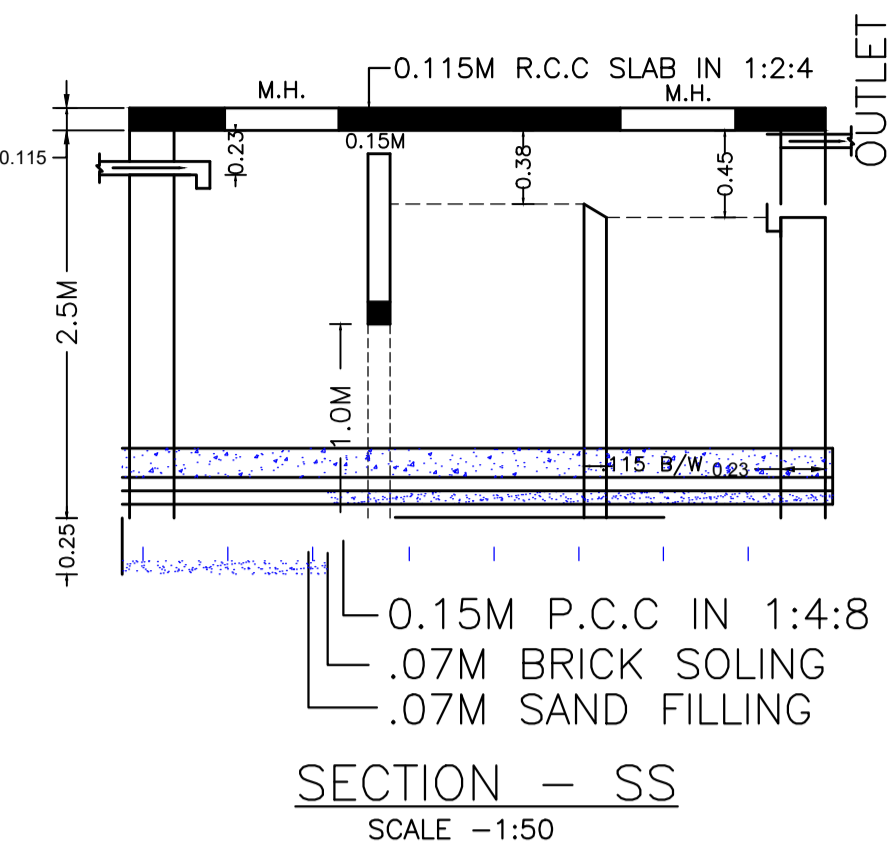
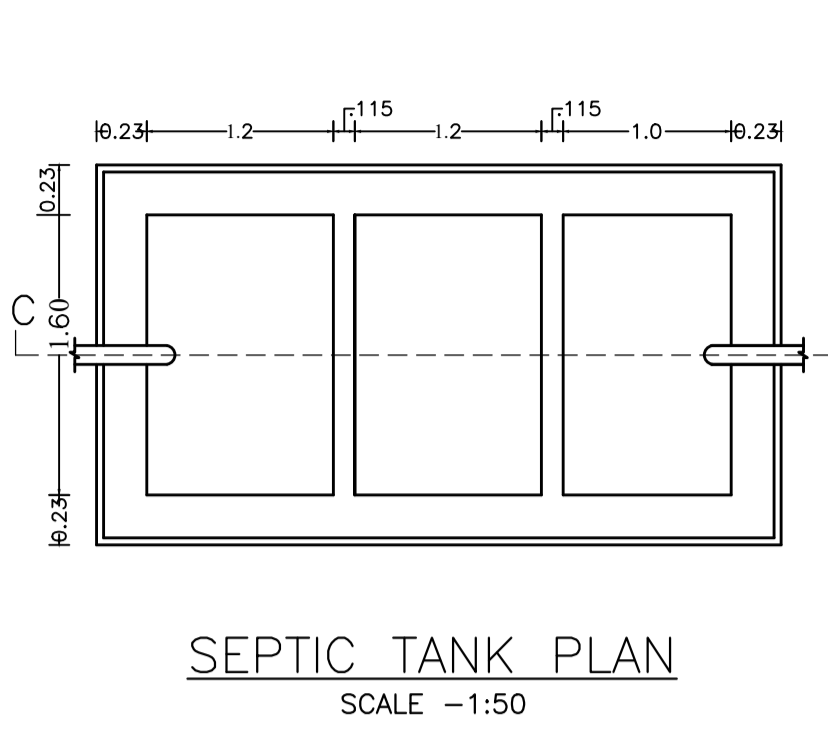
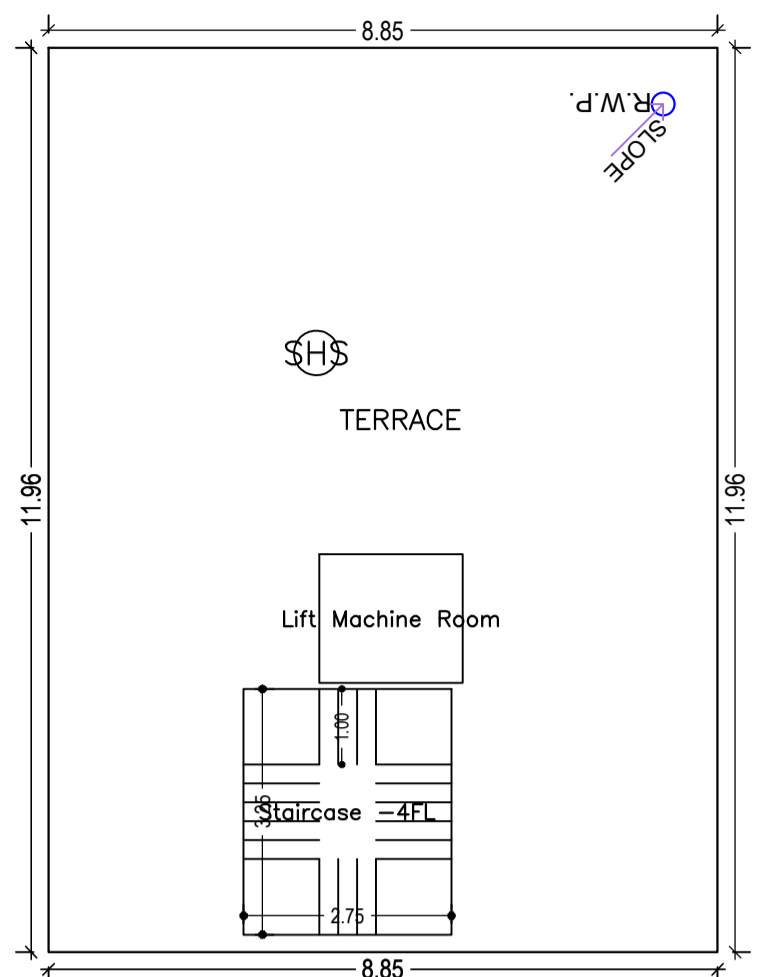
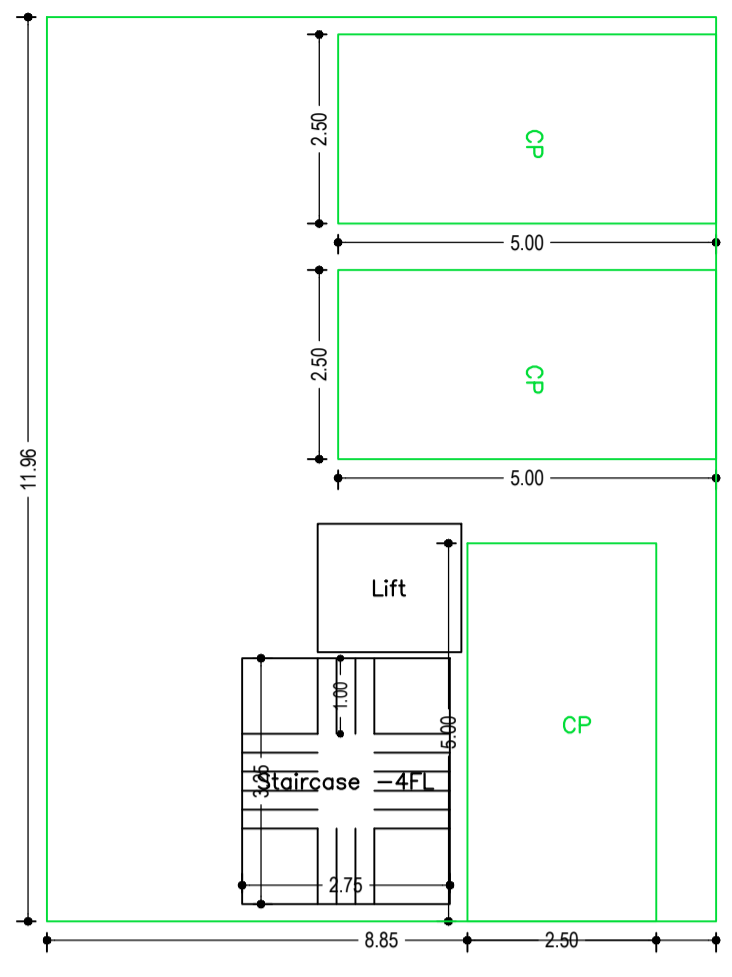

TERRACE FLOOR PLAN (SCALE 1:100)

GROUND FLOOR PLAN (SCALE 1:100)

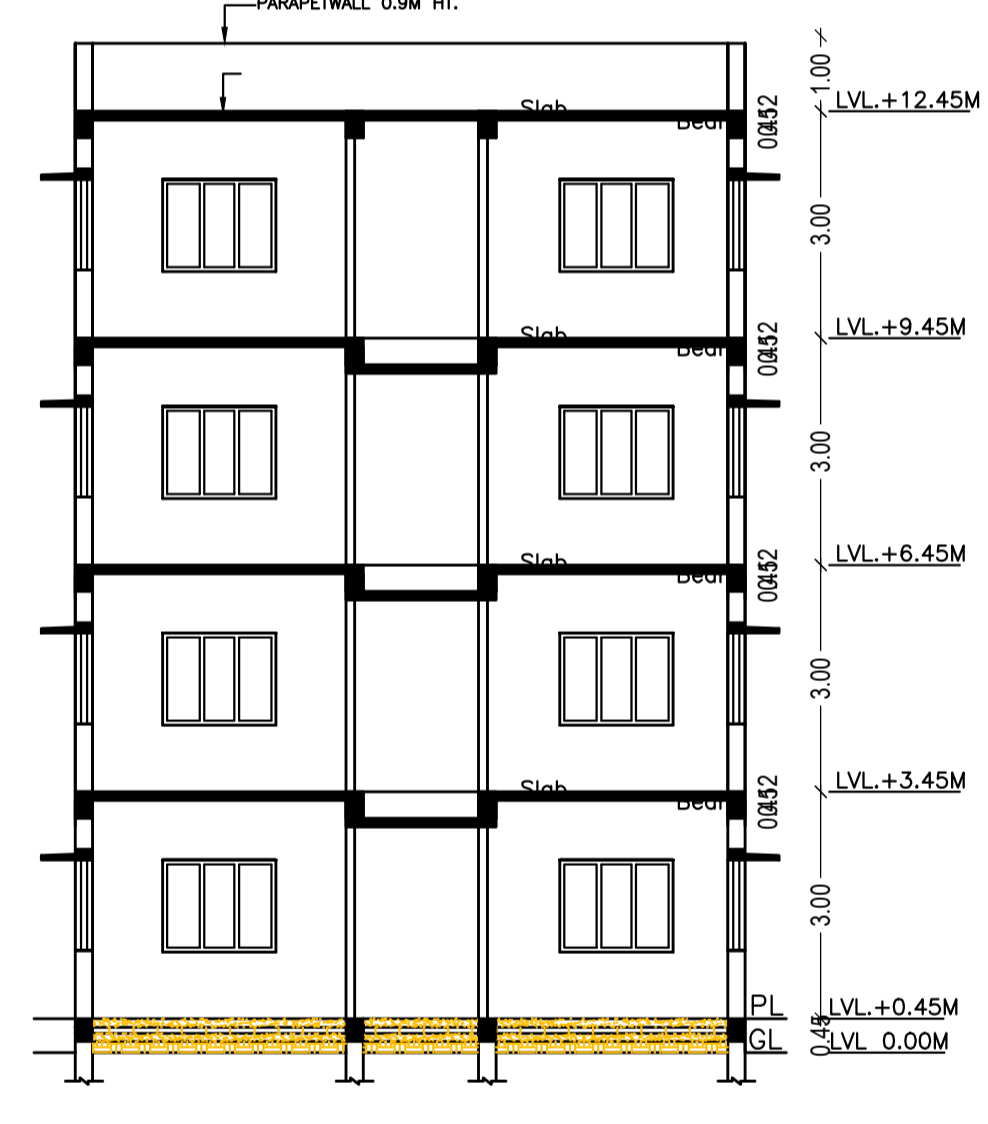
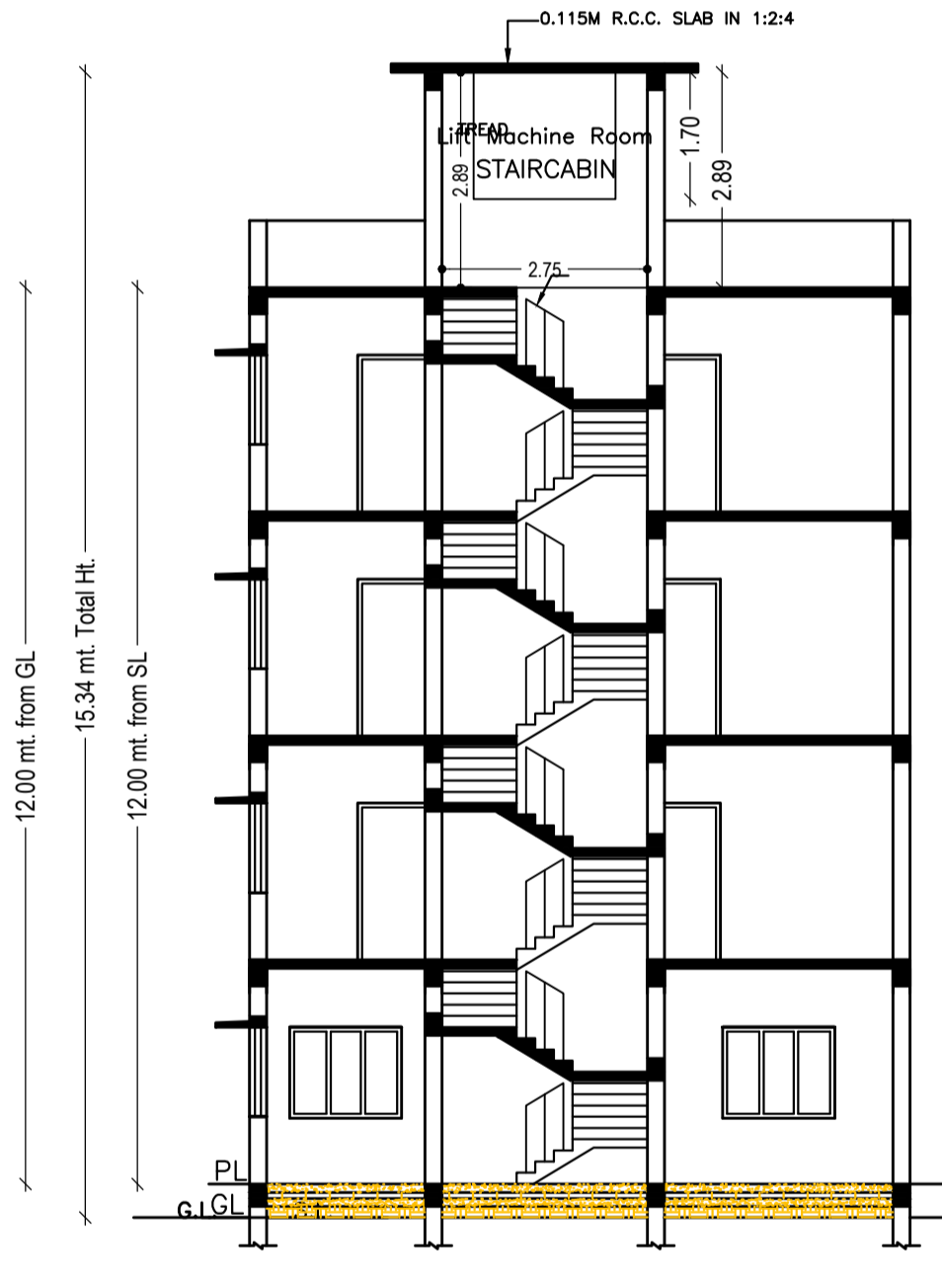
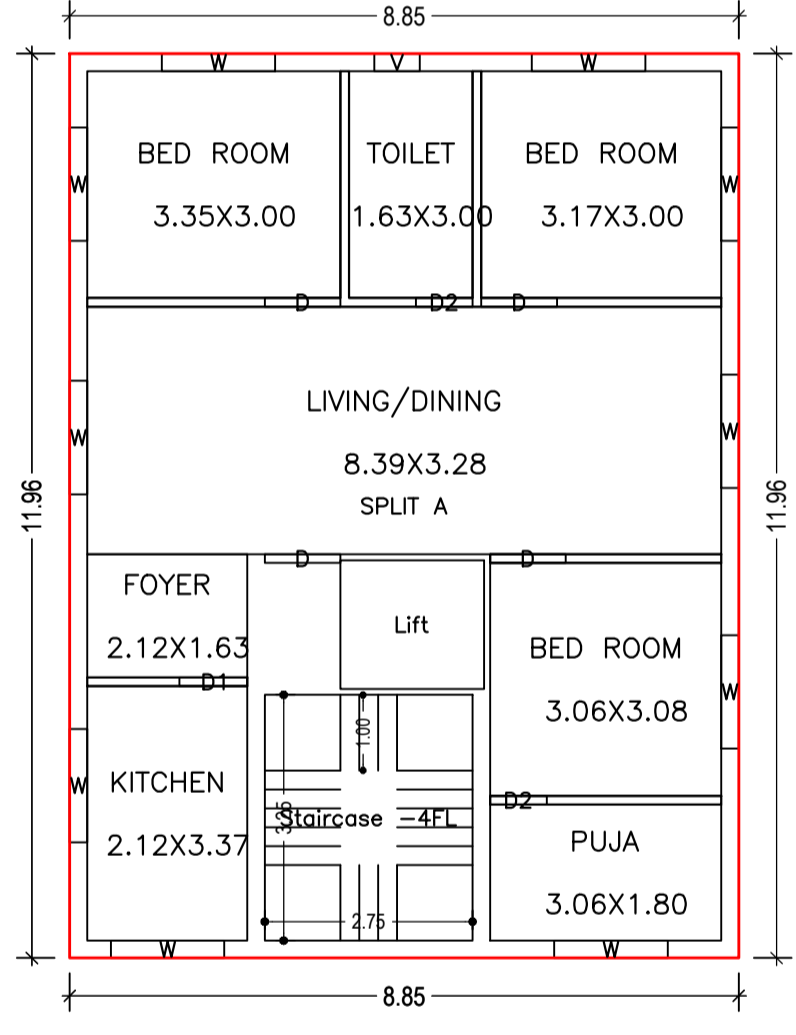

SECTION - AA (SCALE 1:100)

SECTION - BB (SCALE 1:100)

TYPICAL - 1- 3 FLOOR PLAN (Proposed) (SCALE 1:100)

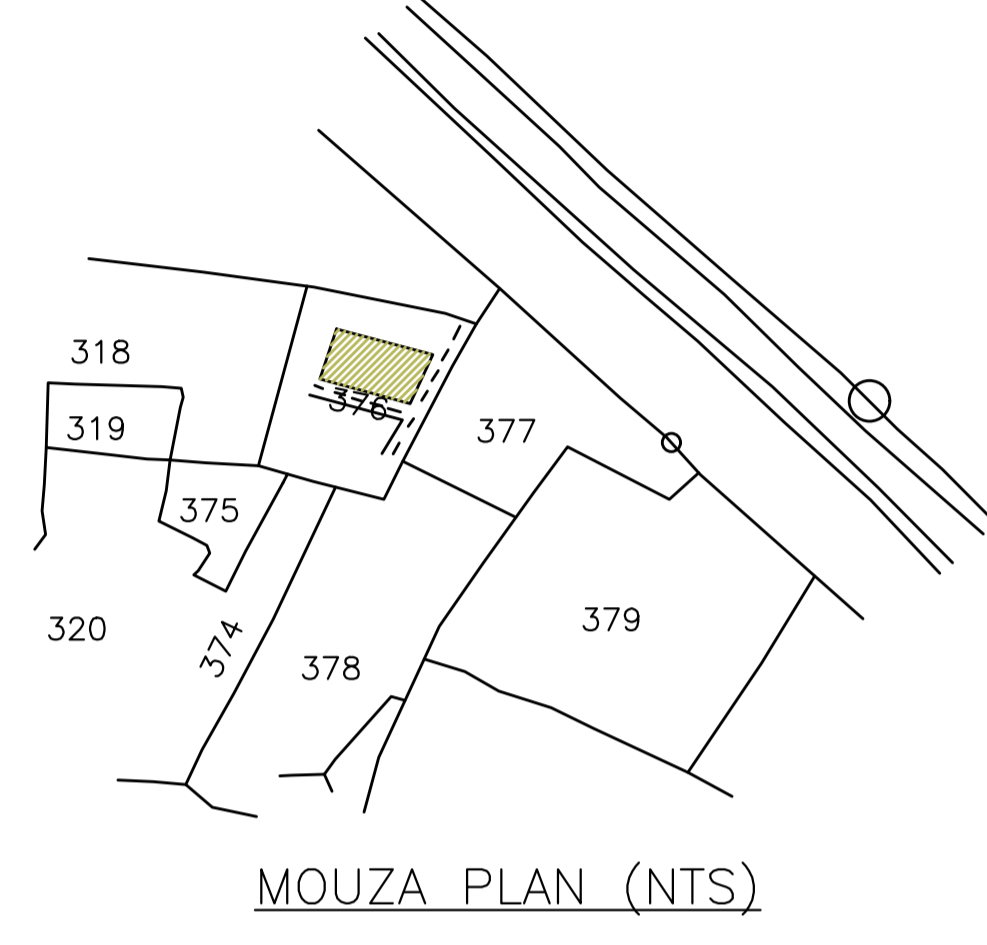

MOUZA PLAN (NTS)

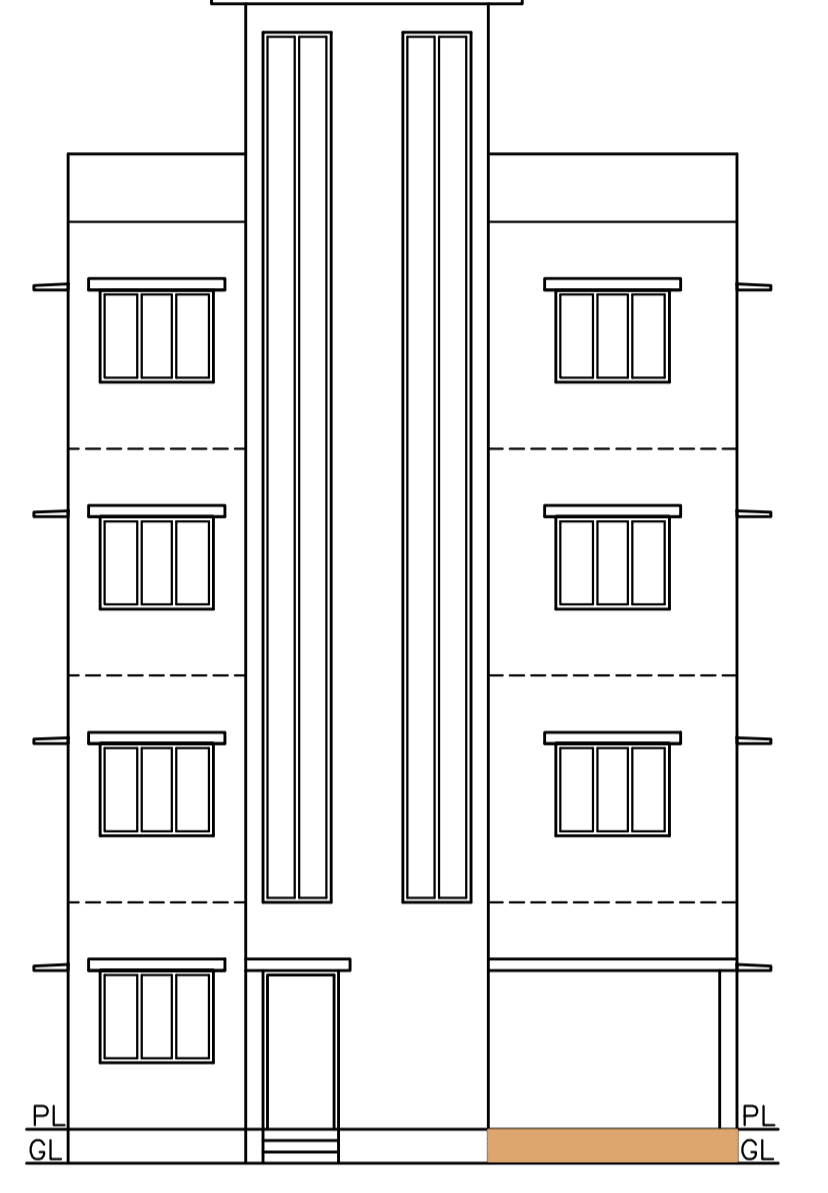

FRONT ELEVATION (SCALE 1:100)

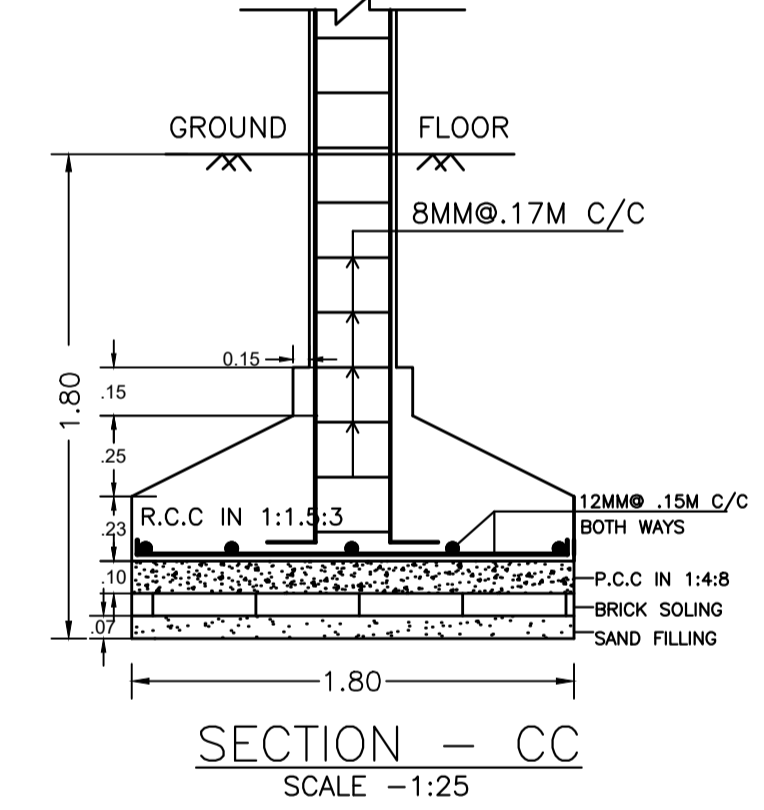

SECTION - CC (SCALE -1:25)

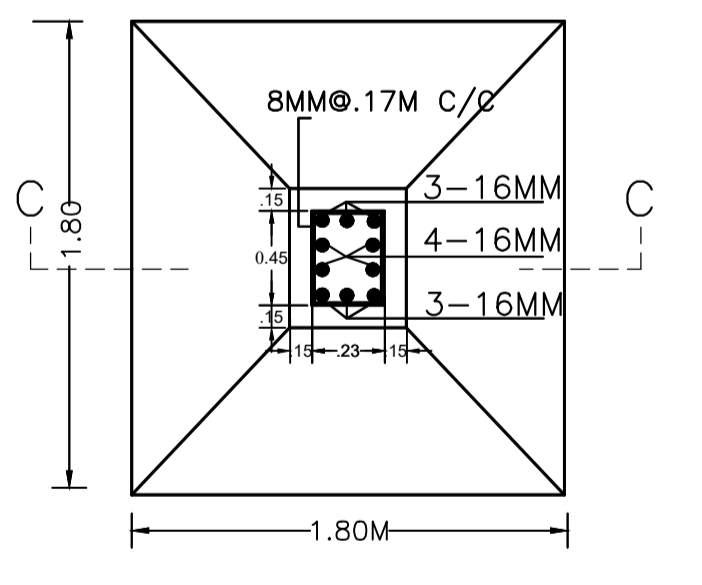

R.C.C. COL. FDN. PLAN (SCALE -1:25)

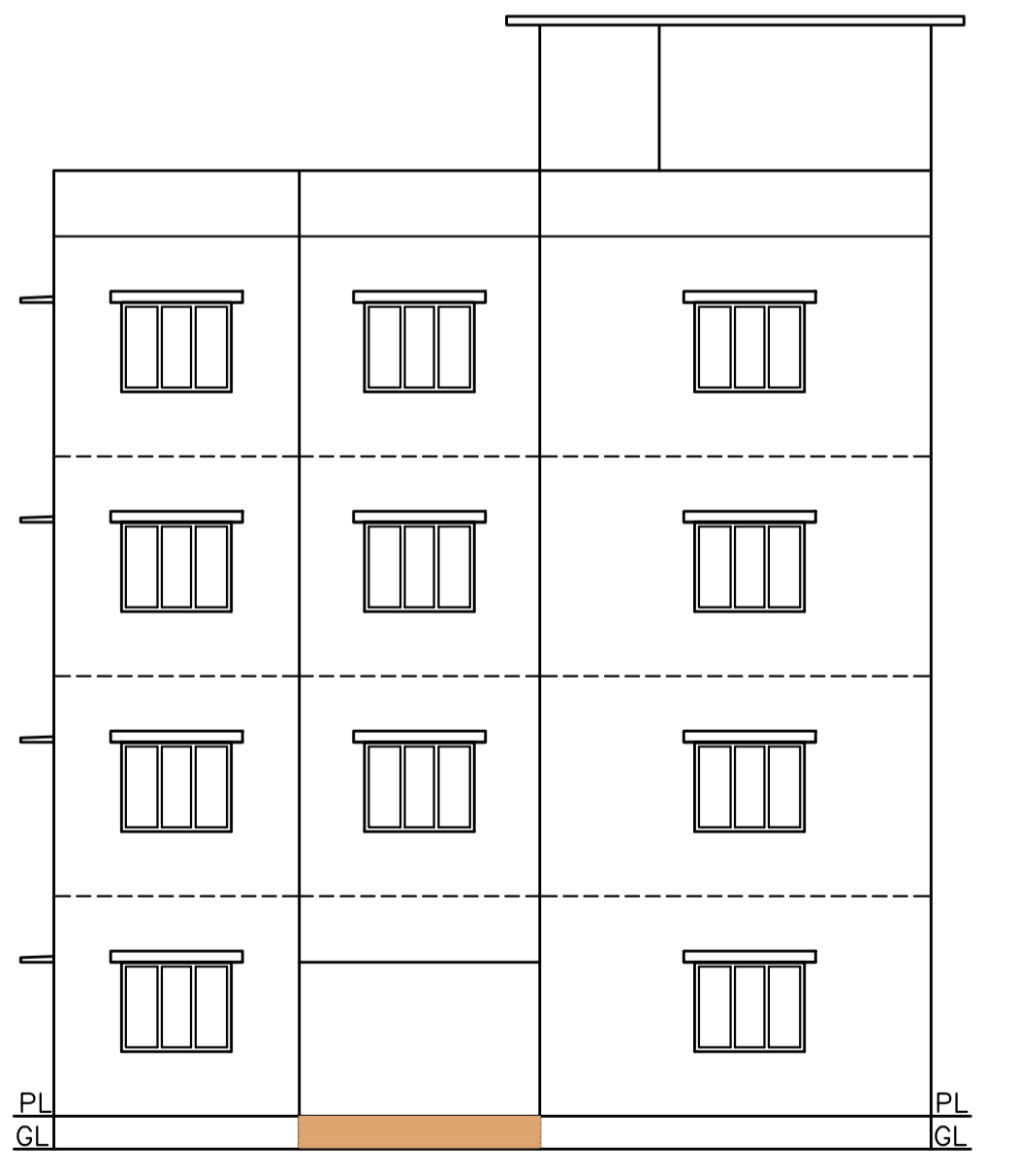

SOUTH SIDE ELEVATION (SCALE 1:100)

Building :A (RESIDENTIAL)

Floor Name	Total Built Up Area (Sq.mt.)	Deductions (Area in Sq.mt.)		Proposed FAR Area (Sq.mt.)	Add Area In FAR (Sq.mt.)	Total FAR Area (Sq.mt.)	Total Consumed Additional FAR Area (Sq.mt.)	Tnmt (No.)
		Lift	Parking					
Ground Floor	105.85	0.00	93.68	0.00	8.94	12.17	12.17	00
First Floor	105.85	3.23	0.00	102.62	0.00	102.62	102.62	01
Second Floor	105.85	3.23	0.00	102.62	0.00	102.62	102.62	01
Third Floor	105.85	3.23	0.00	102.62	0.00	102.62	102.62	01
Terrace Floor	0.00	0.00	0.00	0.00	0.00	0.00	0.00	00
Total :	423.40	9.69	93.68	307.86	8.94	320.03	320.03	03
Total Number of Same Buildings	1							
Total :	423.40	9.69	93.68	307.86	8.94	320.03	320.03	03

SCHEDULE OF DOOR:

BUILDING NAME	NAME	LENGTH	HEIGHT	NOS
A (RESIDENTIAL)	D2	0.75	2.10	06
A (RESIDENTIAL)	D1	0.90	2.10	03
A (RESIDENTIAL)	D	1.00	2.10	12

SCHEDULE OF WINDOW/VENTILATION:

BUILDING NAME	NAME	LENGTH	HEIGHT	NOS
A (RESIDENTIAL)	V	0.60	0.90	03
A (RESIDENTIAL)	W	1.50	1.50	30

UnitBUA Table for Building :A (RESIDENTIAL)

FLOOR	Name	UnitBUA Type	UnitBUA Area	Carpet Area	No. of Rooms	No. of Tenement
TYPICAL - 1- 3 FLOOR PLAN	SPLIT A	FLAT	80.08	77.48	8	3
Total:	-	-	240.25	232.44	24	3

LTP NAME AND SIGNATURE	STRUCTURAL ENG'S NAME AND SIGNATURE	BUILDER NAME AND SIGNATURE	DIGITAL SIGNATURE
EJAZ AHMAD MNAC/DFTMN/0008/2020			

Proposal Basic Information

Proposal File No.	MNAC/BP/0053/W09/2023
Owner Name	MRS. MEERA PANDEY
Khata No	131
Plot No	376
Village Name	Pardih
Use	Residential
SubUse	Bungalow/ Dwelling / Non Apartment

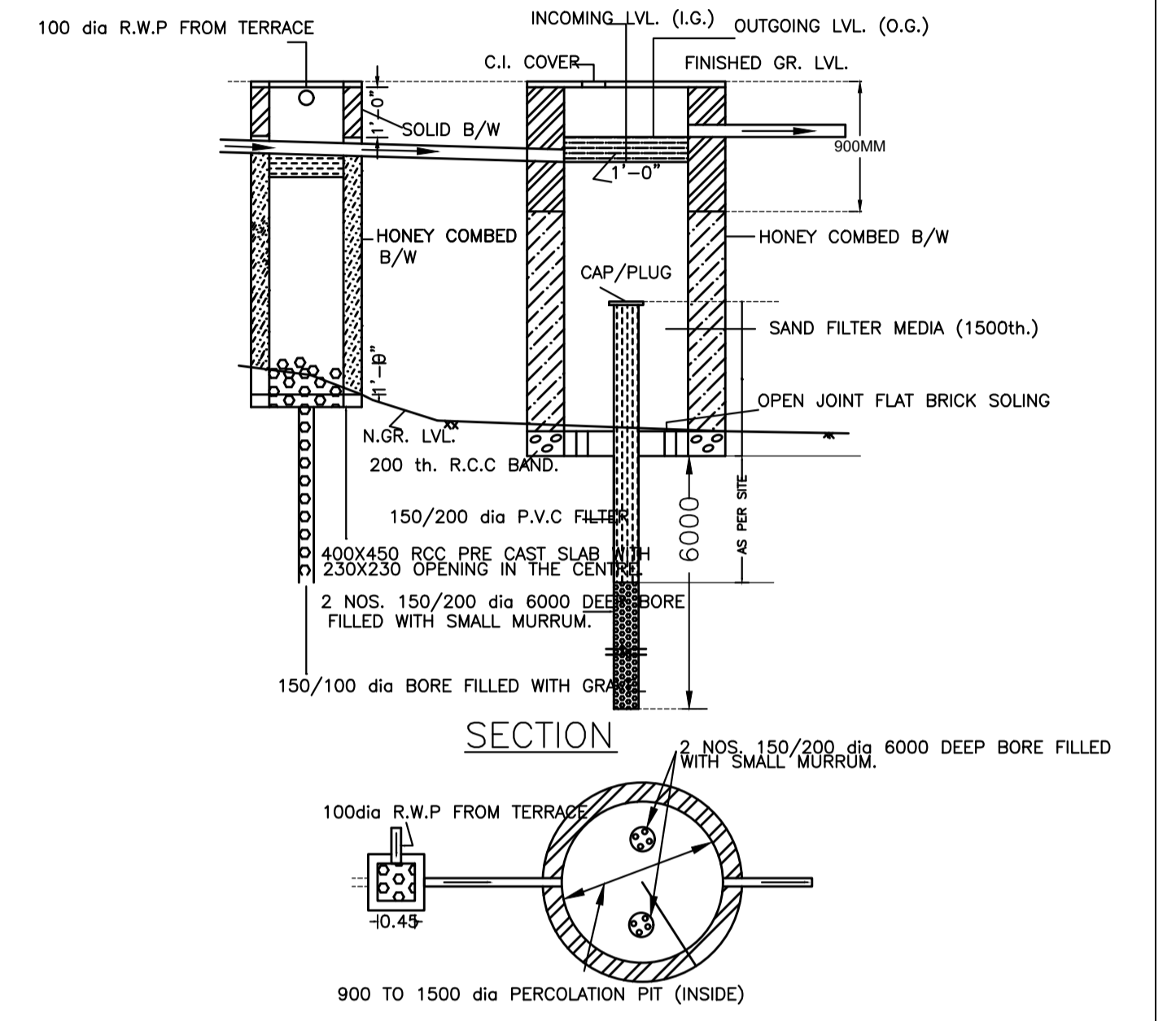

WATER HARVESTING PLAN (NTS)

LTP NAME AND SIGNATURE	STRUCTURAL ENG'S NAME AND SIGNATURE	BUILDER NAME AND SIGNATURE	DIGITAL SIGNATURE
EJAZ AHMAD MNAC/DFTMN/0008/2020			