

SITE PLAN

FAR & Tenement Details (Table 4c-1)

Building	No. of Same Bldg	Total Built Up Area (Sq.mt.)	Deductions (Area in Sq.mt.)		Proposed FAR Area (Sq.mt.)	Add Area In FAR (Sq.mt.)	Total FAR Area (Sq.mt.)	Total Consumed Additional FAR Area (Sq.mt.)	Tenmt (No.)
			Parking	Resi.					
A (RESIDENTIAL)	1	240.39	67.70	163.57	163.57	9.13	172.69	172.69	01
Grand Total :	1	240.39	67.70	163.57	163.57	9.13	172.69	172.69	01

Proposal Basic Information

Proposal File No.	MNAC/BP/0016/W10/2023
Owner Name	MRS. MANORMA DEVI
Khata No	425
Plot No	1465
Village Name	Baliguma
Use	Residential
SubUse	Bungalow/ Dwelling / Non Apartment

AREA STATEMENT MANGO MUNICIPAL CORPORATION	VERSION NO: 1.0.66	VERSION DATE: 16/10/2020
PROJECT DETAIL:		
Region: JHARKHAND URBAN LOCAL BODIES	Plot Use: Residential	
District: EAST SINGHBHUM	Plot SubUse: Bungalow/ Dwelling / Non Apartment	
Authority: MANGO MUNICIPAL CORPORATION	PlotNearbyReligiousStructure: NA	
Inward No: MNAC/BP/0016/W10/2023	PlotSubPlot No: 1465	
Application Type: General Proposal	North: Plot No. - 1466	
Project Type: Building Permission	South: Plot No. - 1463	
Nature of Development: New	East: Road Width - 6.10	
Location of Development Area: Old Area	West: Plot No. - 1462	
AREA DETAILS:		
AREA OF PLOT (Minimum)	(A)	133.56
NET AREA OF PLOT(Gross Plot Area - Deduction from Gross Plot area)	(A-Deductions)	133.56
Deduction for Balance Plot Area(from Gross Plot Area)		
Common Plot		15.85
Total		15.85
BALANCE AREA OF PLOT(Net Plot Area - Recreational/Amenity space)	(A-Deductions)	117.71
PLOT AREA FOR COVERAGE(Net Plot Area)	(A-Deductions)	133.56
Plot Area for FAR (Net Plot Area + Road Widening Area)	(A-Deductions)	133.56
COVERAGE CHECK		
Permissible Coverage area (70.00 %)		93.49
Proposed Coverage Area (60.00 %)		80.13
Total Prop. Coverage Area (60 %)		80.13
Balance coverage area (10.00 %)		13.36
FAR CHECK		
Perm. FAR Area (2.500)		333.90
Total Perm. FAR area		333.90
Residential FAR		163.57
Proposed FAR Area		172.70
Total Proposed FAR Area		172.70
Consumed FAR (Factor)		1.29
Balance FAR Area		161.20
BUILT UP AREA CHECK		
Total Proposed BuiltUp Area		240.39
ARCHITECT (Regd)	Chandrika Sharma	
ENGINEER (Regd)		
SUPERVISOR (Regd)		
OWNER (Regd)	MRS. MANORMA DEVI	
DEVELOPMENT AUTHORITY		LOCAL BODY

COLOR INDEX	
PLOT BOUNDARY	Black
ABUTTING ROAD	Green
PROPOSED CONSTRUCTION	Red
COMMON PLOT	Yellow
ROAD WIDENING AREA	Orange
EXISTING (To be retained)	Blue
EXISTING (To be demolished)	Light Blue

Buildingwise Floor FAR Details

Floor Name	Building Name A (RESIDENTIAL)		Total	
	Proposed Built Up Area (Sq.mt.)	Proposed FAR Area (Sq.mt.)	Total Proposed Built Up Area (Sq.mt.)	Total FAR Area (Sq.mt.)
Ground Floor	80.13	12.43	80.13	12.43
First Floor	80.13	80.13	80.13	80.13
Second Floor	80.13	80.13	80.13	80.13
Terrace Floor	0.00	0.00	0.00	0.00
Total :	240.39	172.69	240.39	172.69

Building USE/SUBUSE Details

Building Name	Building Use	Building SubUse	Building Structure
A (RESIDENTIAL)	Residential	Bungalow/ Dwelling / Non Apartment	Non-Highrise

LTP NAME AND SIGNATURE	STRUCTURAL ENG'S NAME AND SIGNATURE	BUILDER NAME AND SIGNATURE	DIGITAL SIGNATURE
Chandrika Sharma MNAC/DFTMN/0017/2017			

Proposal Basic Information	
Proposal File No.	MNAC/BP/0016/W10/2023
Owner Name	MRS. MANORMA DEVI
Khata No	425
Plot No	1465
Village Name	Baliguma
Use	Residential
SubUse	Bungalow/ Dwelling / Non Apartment

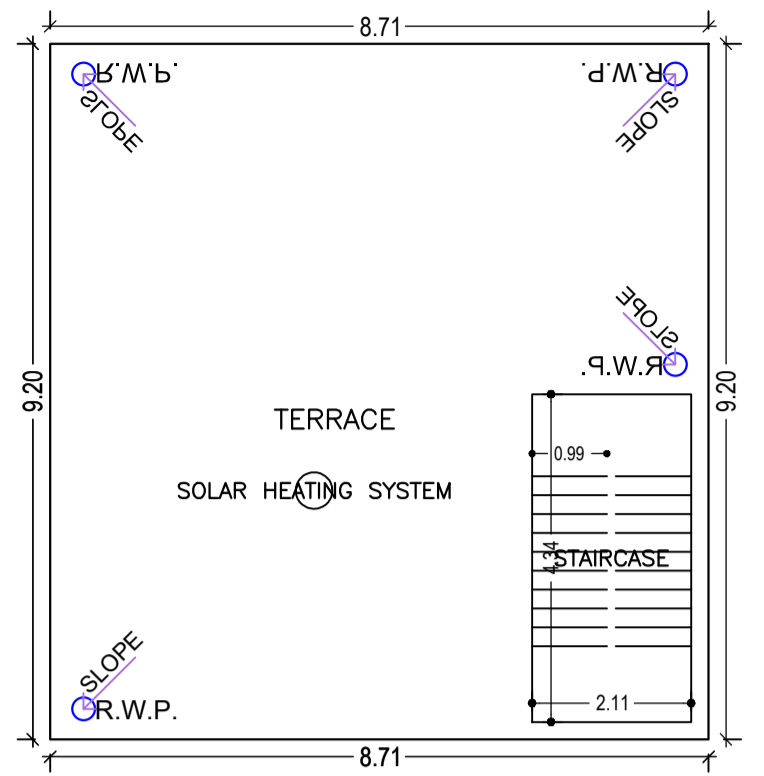
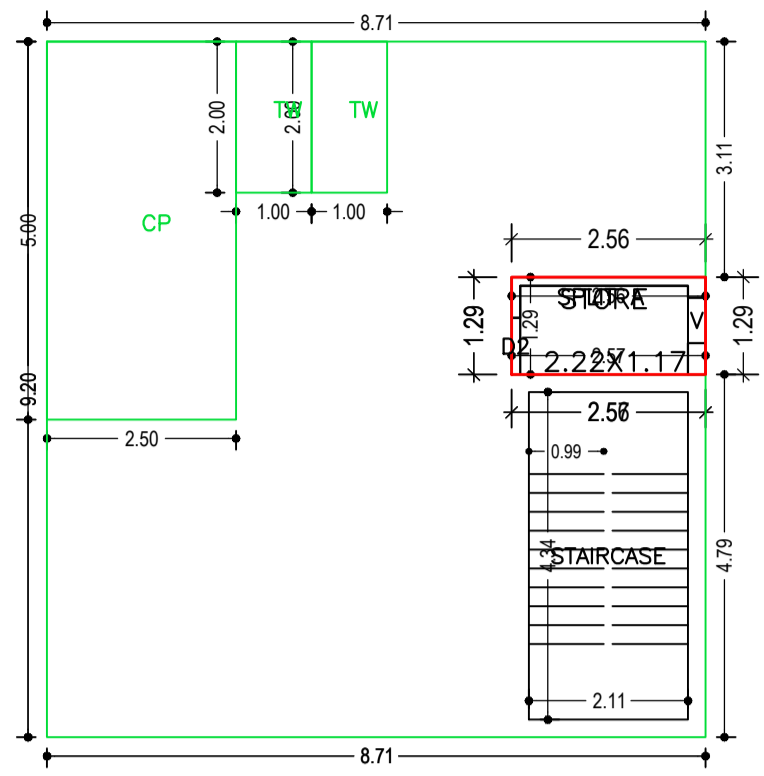

TERRACE FLOOR PLAN (SCALE 1:100)

GROUND FLOOR PLAN (Proposed) (SCALE 1:100)

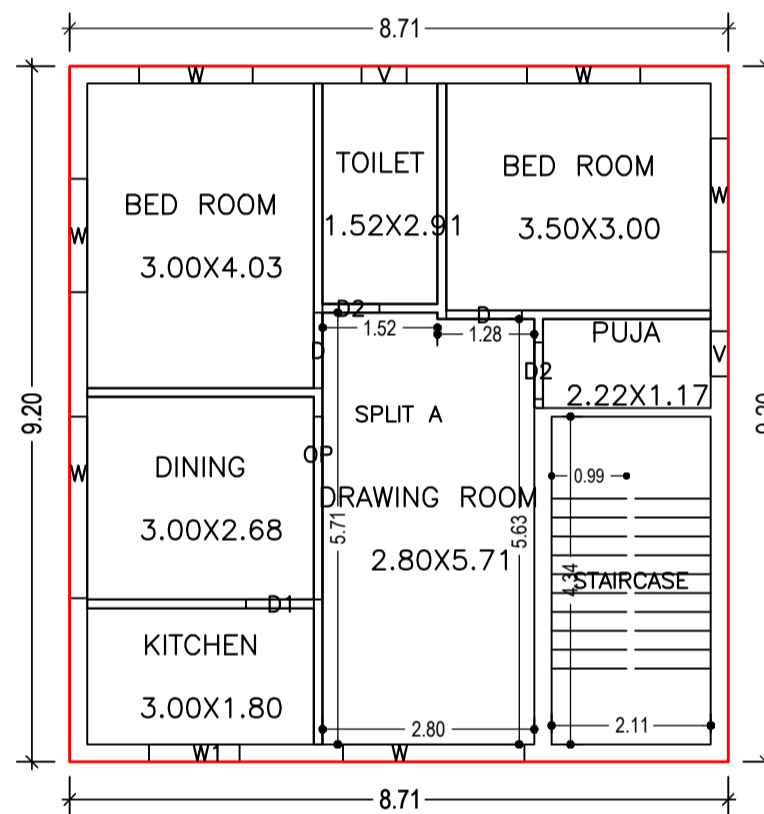

TYPICAL - 1 & 2 FLOOR PLAN (Proposed) (SCALE 1:100)

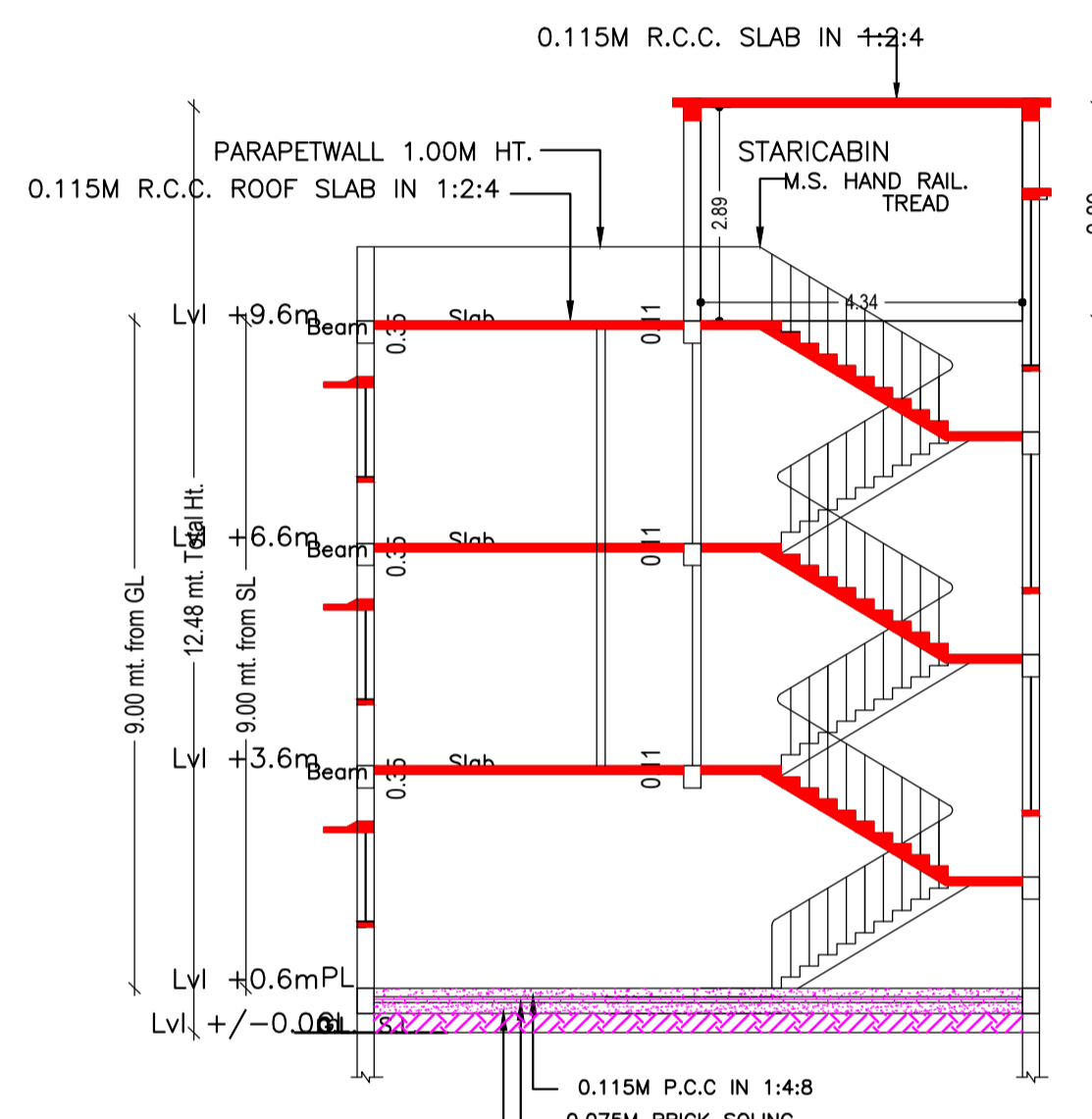

SECTION -A A SCALE 1:100

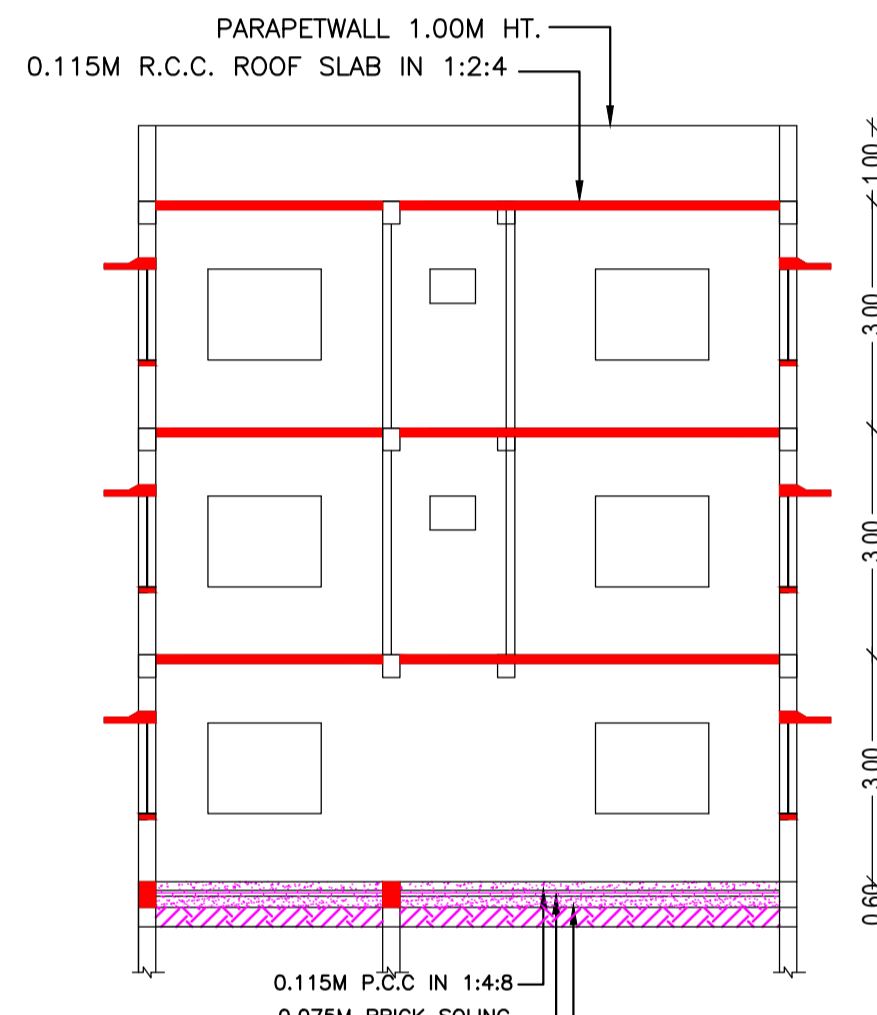

SECTION -B B SCALE 1:100

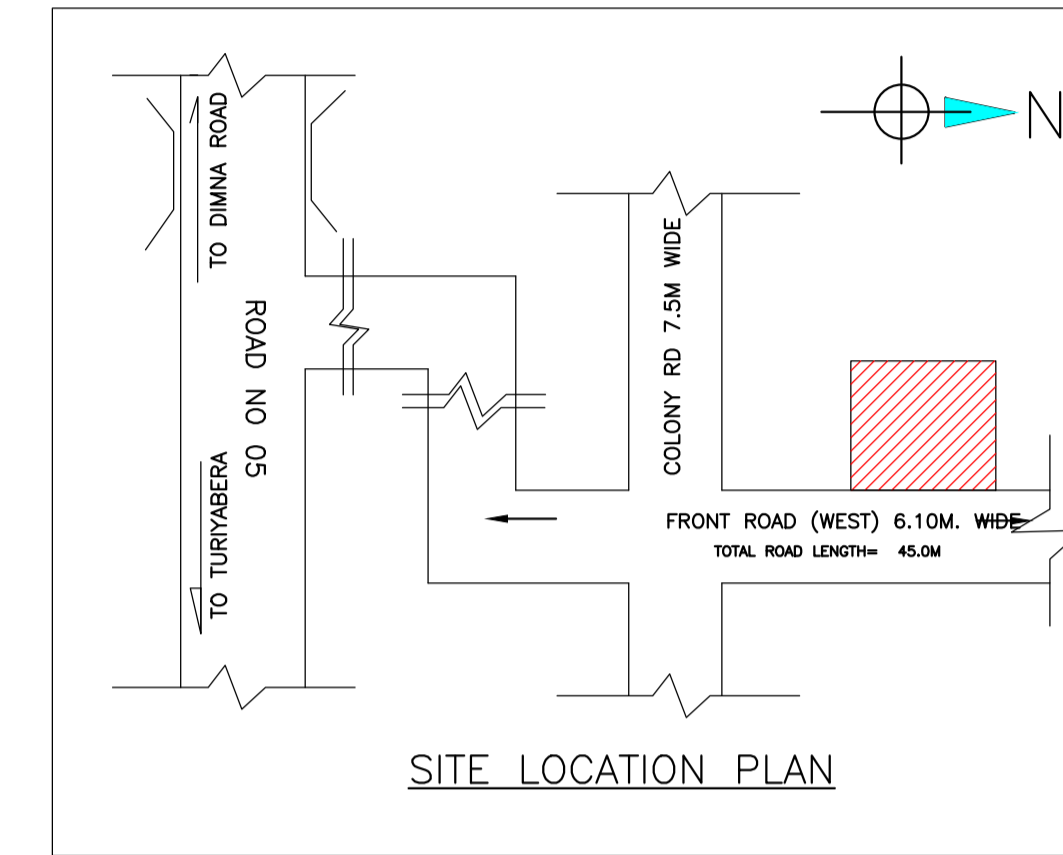

SITE LOCATION PLAN

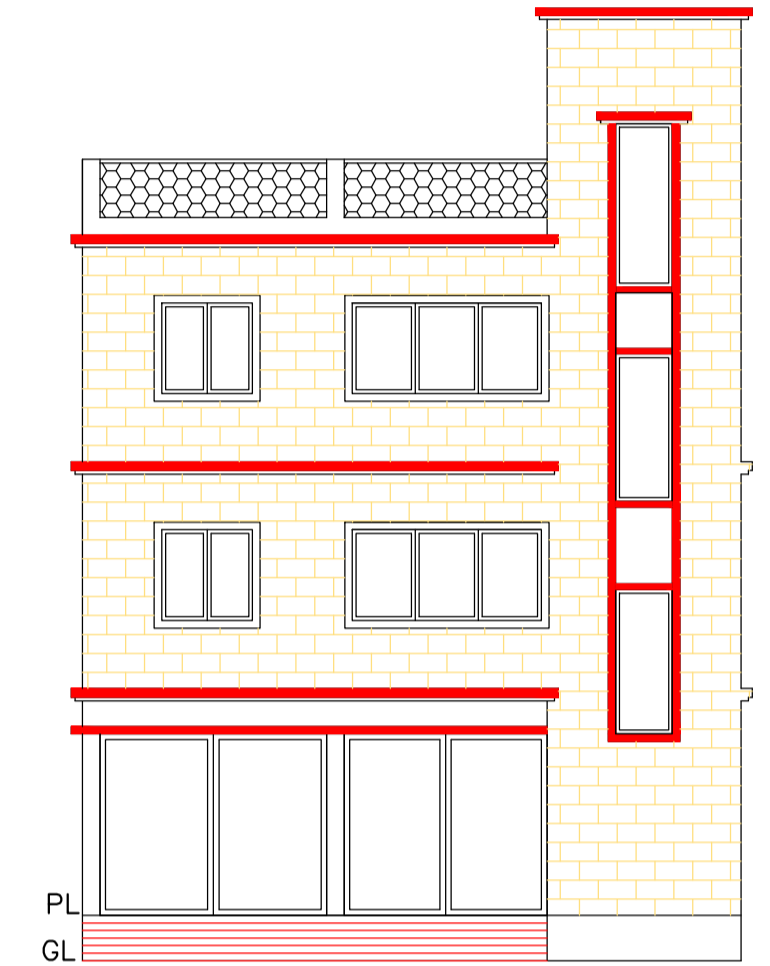

FRONT ELEVATION SCALE 1:100

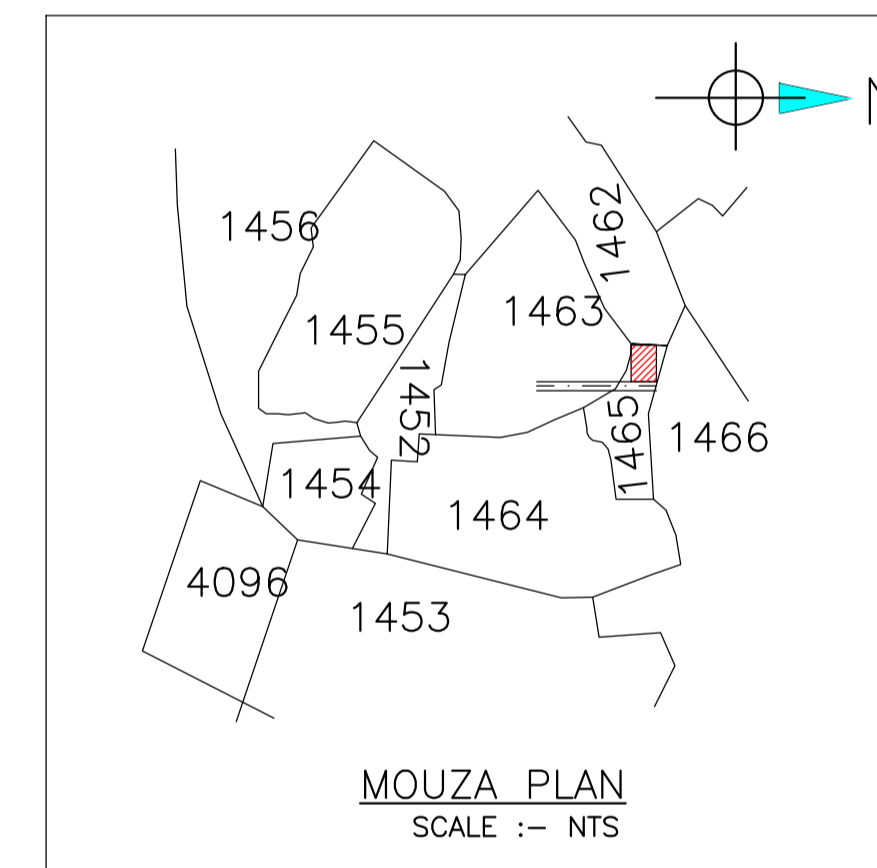

MOUZA PLAN SCALE :- NTS

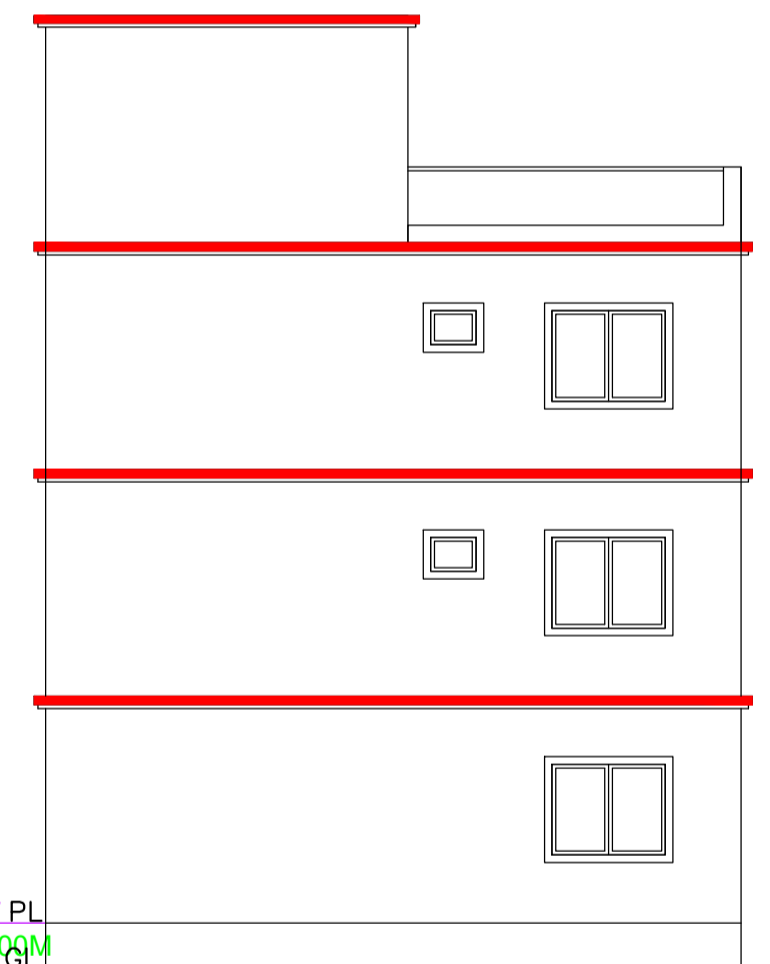

NORTH SIDE ELEVATION SCALE 1:100

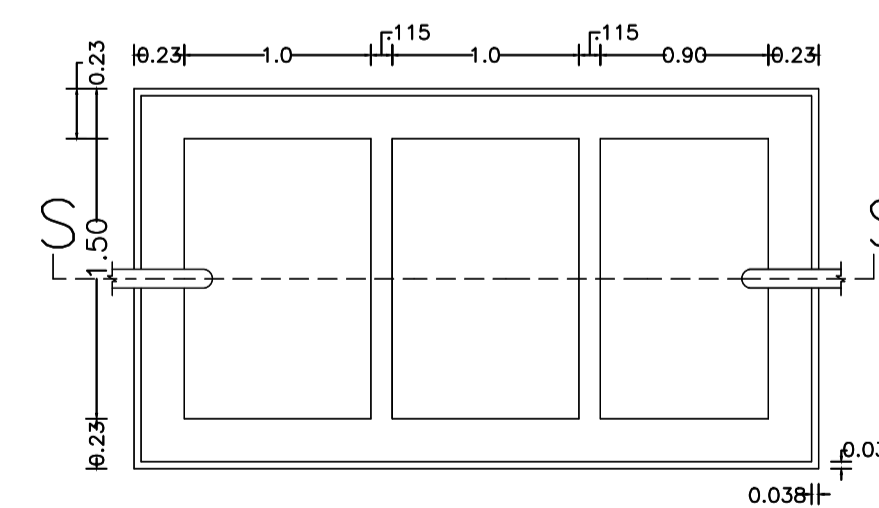

SEPTIC TANK PLAN

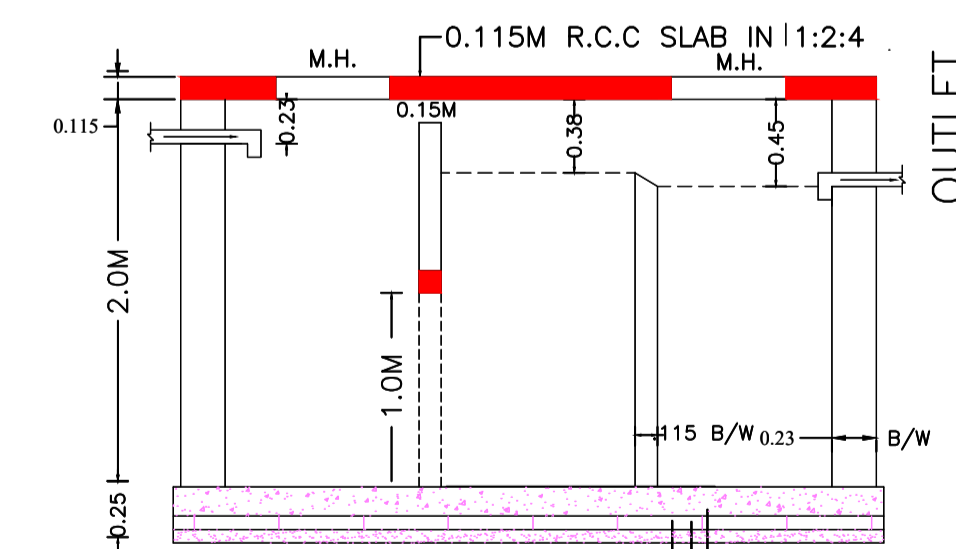

SECTION - SS SCALE - 1:50

Building :A (RESIDENTIAL)

Floor Name	Total Built Up Area (Sq.mt.)	Deductions (Area in Sq.mt.)		Proposed FAR Area (Sq.mt.)	Add Area in FAR (Sq.mt.)		Total FAR Area (Sq.mt.)	Total Consumed Additional FAR Area (Sq.mt.)	Trmt (No.)
		Parking	Resi.		Stair				
Ground Floor	80.13	67.70	3.31	9.13	12.43	12.43	01		
First Floor	80.13	0.00	80.13	0.00	80.13	80.13	00		
Second Floor	80.13	0.00	80.13	0.00	80.13	80.13	00		
Terrace Floor	0.00	0.00	0.00	0.00	0.00	0.00	00		
Total :	240.39	67.70	163.57	9.13	172.69	172.69	01		
Total Number of Same Buildings	1								
Total :	240.39	67.70	163.57	9.13	172.69	172.69	01		

SCHEDULE OF DOOR:

BUILDING NAME	NAME	LENGTH	HEIGHT	NOS
A (RESIDENTIAL)	D2	0.75	2.10	05
A (RESIDENTIAL)	D1	0.90	2.10	02
A (RESIDENTIAL)	D	1.00	2.10	04
A (RESIDENTIAL)	OP	2.42	2.10	02

SCHEDULE OF WINDOW/VENTILATION:

BUILDING NAME	NAME	LENGTH	HEIGHT	NOS
A (RESIDENTIAL)	V	0.60	0.90	05
A (RESIDENTIAL)	W1	1.20	1.20	02
A (RESIDENTIAL)	W	1.50	1.20	08
A (RESIDENTIAL)	W	2.40	1.20	04

UnitBUA Table for Building :A (RESIDENTIAL)

FLOOR	Name	UnitBUA Type	UnitBUA Area	Carpet Area	No. of Rooms	No. of Tenement
TYPICAL - 1 & 2 FLOOR PLAN	SPLIT A	FLAT	0.00	0.00	7	0
GROUND FLOOR PLAN	SPLIT A	FLAT	126.74	120.73	1	1
Total:	-	-	126.74	120.73	15	1

LTP NAME AND SIGNATURE	STRUCTURAL ENG'S NAME AND SIGNATURE	BUILDER NAME AND SIGNATURE	DIGITAL SIGNATURE
Chandrika Sharma MNAC/DFTMN/0017/2017			

Proposal Basic Information

Proposal File No.	MNAC/BP/0016/W10/2023
Owner Name	MRS. MANORMA DEVI
Khata No	425
Plot No	1465
Village Name	Baliguma
Use	Residential
SubUse	Bungalow/ Dwelling / Non Apartment

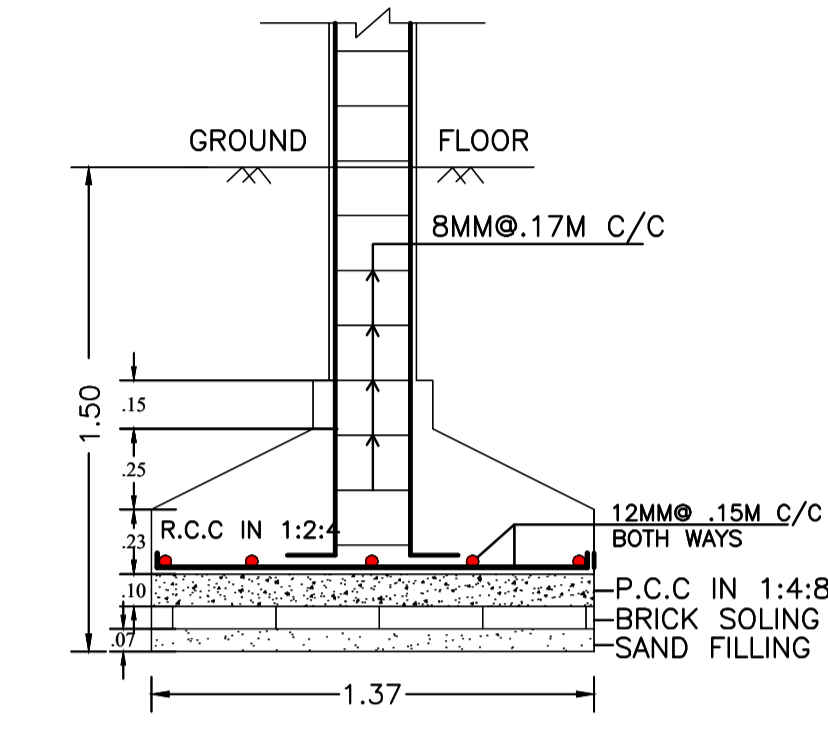

SECTION - CC
SCALE -1:25

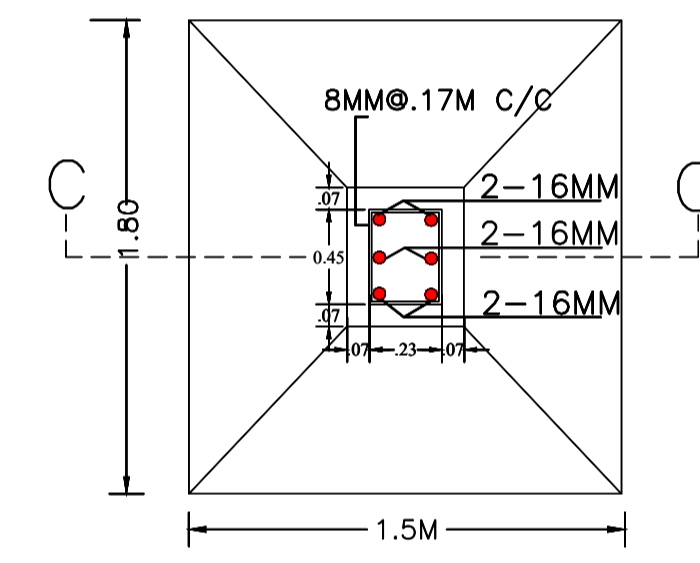

R.C.C. COL. FDN. PLAN
SCALE -1:25

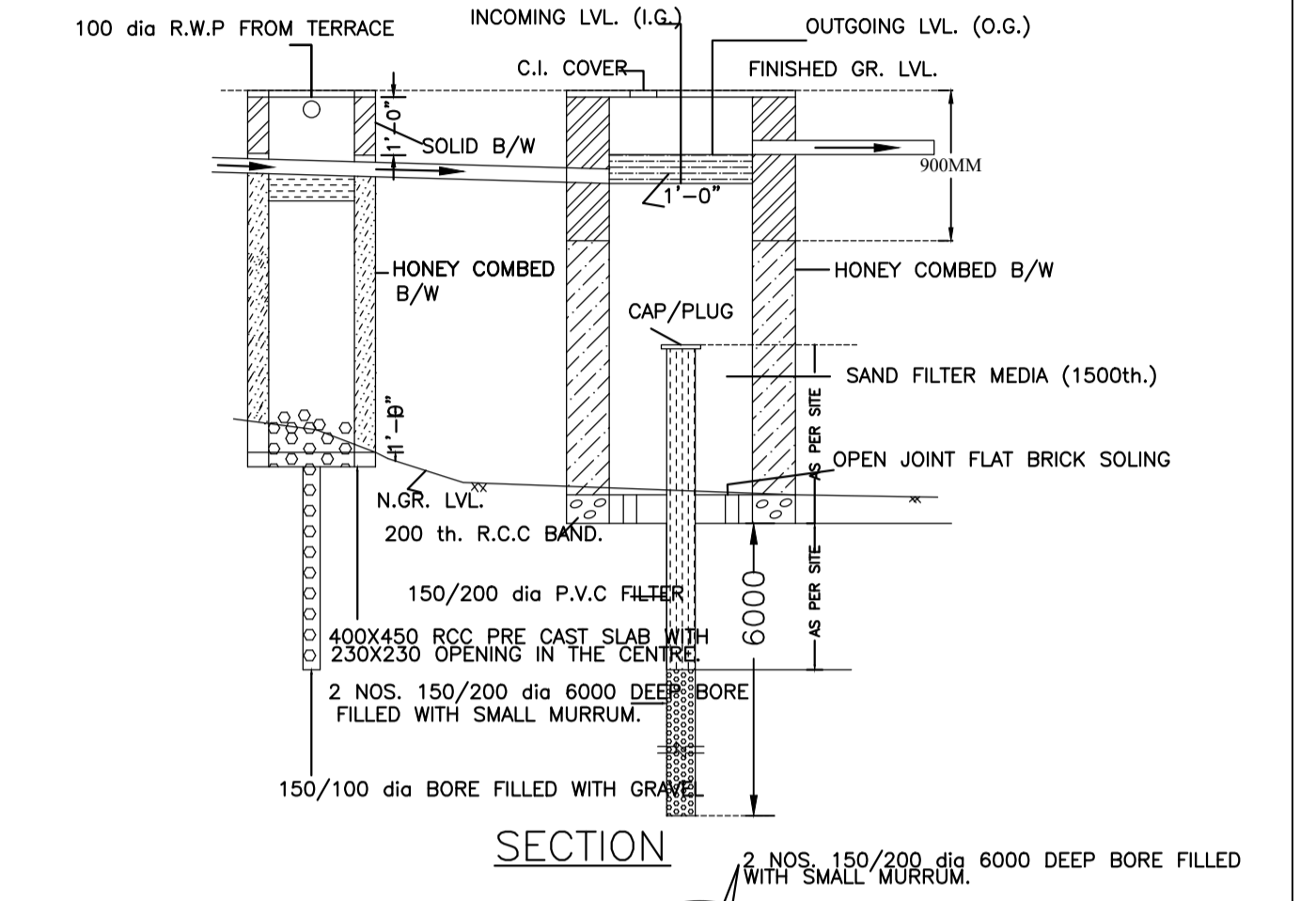

SECTION

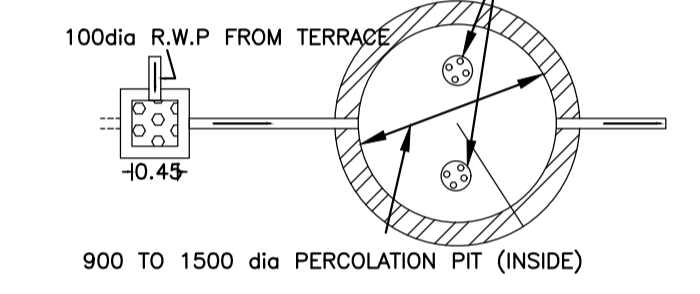

WATER HARVESTING PLAN (NTS)

LTP NAME AND SIGNATURE	STRUCTURAL ENG'S NAME AND SIGNATURE	BUILDER NAME AND SIGNATURE	DIGITAL SIGNATURE
Chandrika Sharma MNAC/DFTMN/0017/2017			