

SITE - PLAN
SCALE 1:100

SITE PLAN

FAR & Tenement Details (Table 4c-1)

Building	No. of Same Bldg	Total Built Up Area (Sq.mt.)	Deductions (Area in Sq.mt.) Parking	Proposed FAR Area (Sq.mt.) Resi.	Total FAR Area (Sq.mt.)	Total Consumed Additional FAR Area (Sq.mt.)	Tnmt (No.)
A (RESIDENTIAL)	1	169.86	21.05	148.81	148.81	148.81	01
Grand Total :	1	169.86	21.05	148.81	148.81	148.81	01

Proposal Basic Information

Proposal File No.	MNAC/BP/0011/W/10/2023
Owner Name	MRS. NIRMALA DEVI
Khata No	425
Plot No	1455
Village Name	Baliguma
Use	Residential
SubUse	Bungalow/ Dwelling / Non Apartment

AREA STATEMENT MANGO MUNICIPAL CORPORATION	VERSION NO.: 1.0.66
	VERSION DATE: 16/10/2020
PROJECT DETAIL:	
Region: JHARKHAND URBAN LOCAL BODIES	Plot Use: Residential
District: EAST SINGHBHUM	Plot SubUse: Bungalow/ Dwelling / Non Apartment
Authority: MANGO MUNICIPAL CORPORATION	PlotNearbyReligiousStructure: NA
Inward No: MNAC/BP/0011/W/10/2023	PlotSubPlot No: 1455
Application Type: General Proposal	North: -
Project Type: Building Permission	South: -
Nature of Development: New	East: -
Location of Development Area: Old Area	West: -
AREA DETAILS:	
AREA OF PLOT (Minimum)	(A) 148.60
NET AREA OF PLOT(Gross Plot Area - Deduction from Gross Plot area)	(A-Deductions) 148.60
Deduction for Balance Plot Area(from Gross Plot Area)	
Common Plot	18.29
Total	18.29
BALANCE AREA OF PLOT(Net Plot Area - Recreational/Amenity space)	(A-Deductions) 130.31
PLOT AREA FOR COVERAGE(Net Plot Area)	(A-Deductions) 148.60
Plot Area for FAR (Net Plot Area + Road Widening Area)	(A-Deductions) 148.60
COVERAGE CHECK	
Permissible Coverage area (70.00 %)	104.02
Proposed Coverage Area (57.15 %)	84.93
Total Prop. Coverage Area (57.15 %)	84.93
Balance coverage area (12.85 %)	19.09
FAR CHECK	
Perm. FAR Area (2.500)	371.50
Total Perm. FAR area	371.50
Residential FAR	148.81
Proposed FAR Area	148.81
Total Proposed FAR Area	148.81
Consumed FAR (Factor)	1.00
Balance FAR Area	222.69
BUILT UP AREA CHECK	
Total Proposed BuiltUp Area	169.86
ARCHITECT (Regd)	EJAZ AHMAD
ENGINEER (Regd)	
SUPERVISOR (Regd)	
OWNER (Regd)	MRS. NIRMALA DEVI
DEVELOPMENT AUTHORITY	LOCAL BODY

COLOR INDEX	
PLOT BOUNDARY	Black
ABUTTING ROAD	Green
PROPOSED CONSTRUCTION	Red
COMMON PLOT	Yellow
ROAD WIDENING AREA	Orange
EXISTING (To be retained)	Blue
EXISTING (To be demolished)	Light Blue

Buildingwise Floor FAR Details

Floor Name	Building Name A (RESIDENTIAL)		Total	
	Proposed Built Up Area (Sq.mt.)	Proposed FAR Area (Sq.mt.)	Total Proposed Built Up Area (Sq.mt.)	Total FAR Area (Sq.mt.)
Ground Floor	84.93	63.88	84.93	63.88
First Floor	84.93	84.93	84.93	84.93
Terrace Floor	0.00	0.00	0.00	0.00
Total :	169.86	148.81	169.86	148.81

Building USE/SUBUSE Details

Building Name	Building Use	Building SubUse	Building Structure
A (RESIDENTIAL)	Residential	Bungalow/ Dwelling / Non Apartment	Non-Highrise

LTP NAME AND SIGNATURE	STRUCTURAL ENG'S NAME AND SIGNATURE	BUILDER NAME AND SIGNATURE	DIGITAL SIGNATURE
EJAZ AHMAD MNAC/DFTMN/0008/2020			

Proposal Basic Information	
Proposal File No.	MNAC/BP/0011/W/10/2023
Owner Name	MRS. NIRMALA DEVI
Khata No	425
Plot No	1455
Village Name	Balguma
Use	Residential
SubUse	Bungalow/ Dwelling / Non Apartment

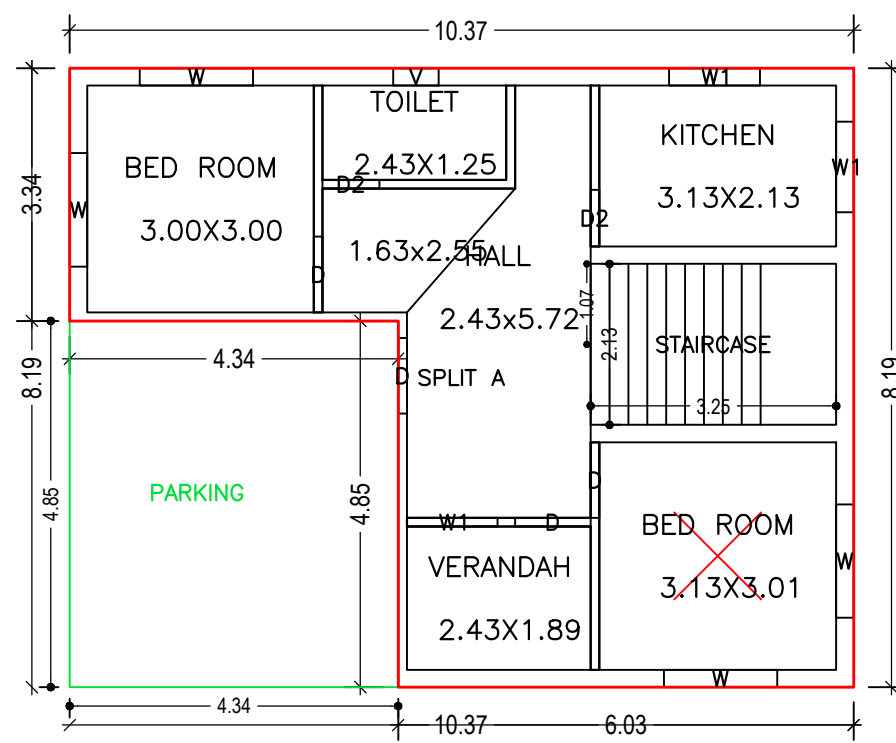

GROUND FLOOR PLAN
(Proposed)
(SCALE 1:100)

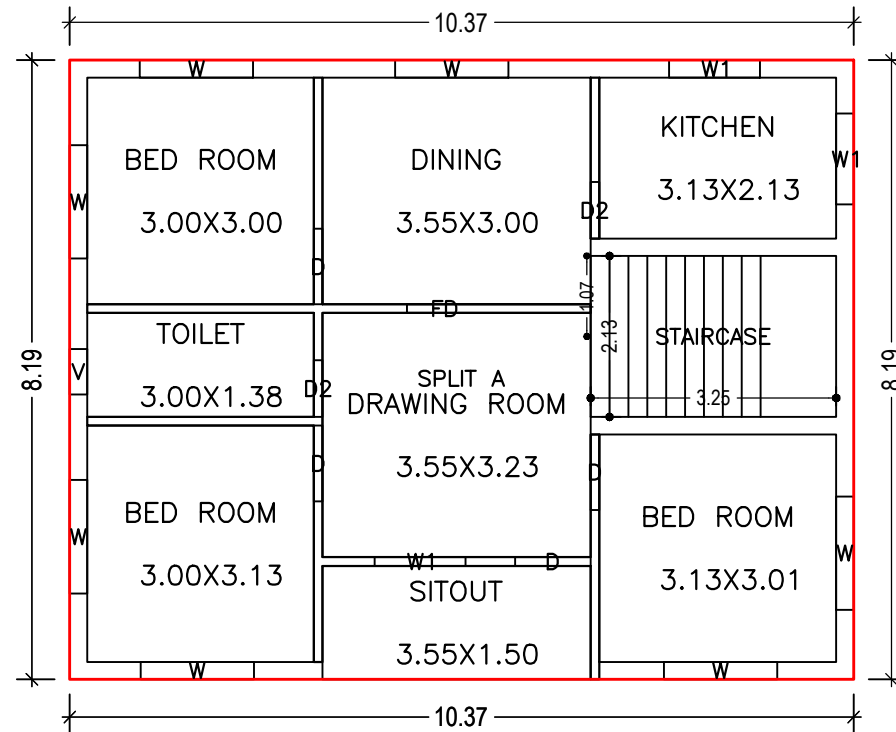

FIRST FLOOR PLAN
(Proposed)
(SCALE 1:100)

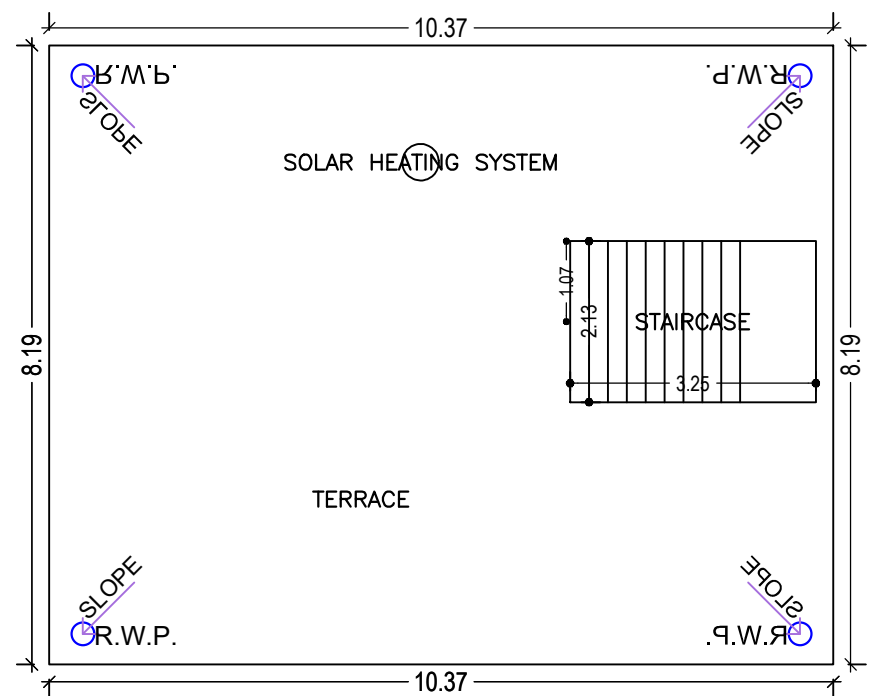

TERRACE FLOOR PLAN
(SCALE 1:100)

Building :A (RESIDENTIAL)

Floor Name	Total Built Up Area (Sq.mt.)	Deductions (Area in Sq.mt.)	Proposed FAR Area (Sq.mt.)	Total FAR Area (Sq.mt.)	Total Consumed Additional FAR Area (Sq.mt.)	Trmt (No.)
Ground Floor	84.93	21.05	63.88	63.88	63.88	01
First Floor	84.93	0.00	84.93	84.93	84.93	00
Terrace Floor	0.00	0.00	0.00	0.00	0.00	00
Total:	169.86	21.05	148.81	148.81	148.81	01
Total Number of Same Buildings	1					
Total:	169.86	21.05	148.81	148.81	148.81	01

SCHEDULE OF DOOR:

BUILDING NAME	NAME	LENGTH	HEIGHT	NOS
A (RESIDENTIAL)	D2	0.75	2.10	04
A (RESIDENTIAL)	D	1.00	2.10	08
A (RESIDENTIAL)	FD	2.43	2.10	01

SCHEDULE OF WINDOW/VENTILATION:

BUILDING NAME	NAME	LENGTH	HEIGHT	NOS
A (RESIDENTIAL)	V	0.60	0.90	02
A (RESIDENTIAL)	W1	1.20	1.20	04
A (RESIDENTIAL)	W1	1.20	2.10	02
A (RESIDENTIAL)	W	1.50	1.50	11

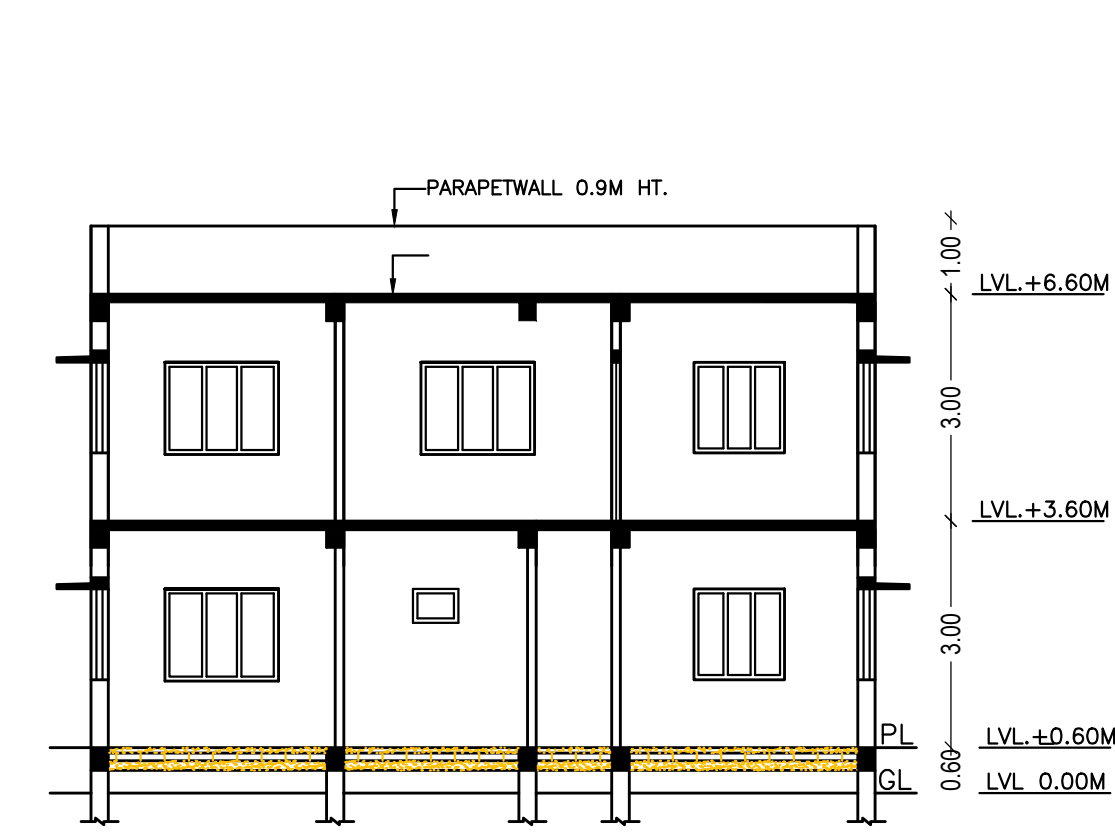

SECTION -AA
SCALE 1:100

SECTION -BB
SCALE 1:100

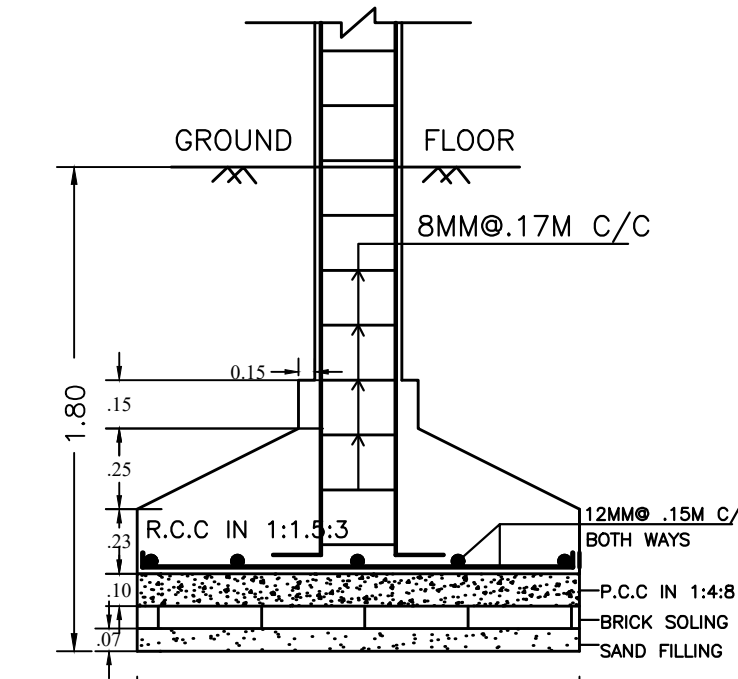

SECTION - CC
SCALE -1:25



FRONT ELEVATION
SCALE 1:100

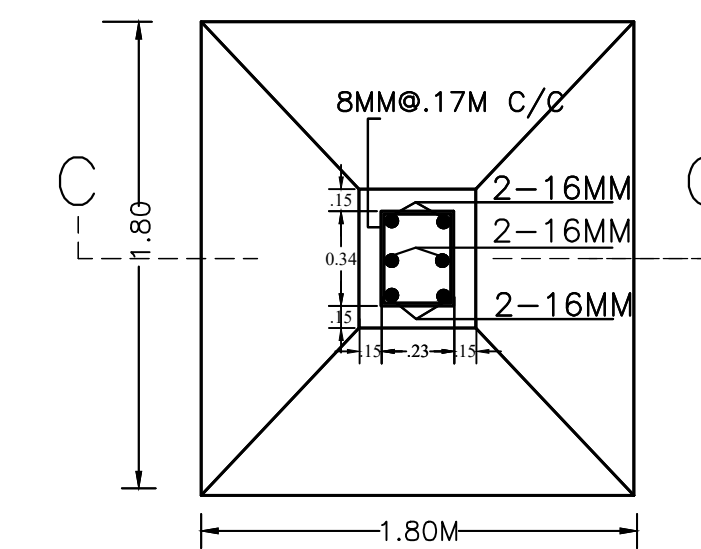

R.C.C. COL. FDN. PLAN
SCALE -1:25

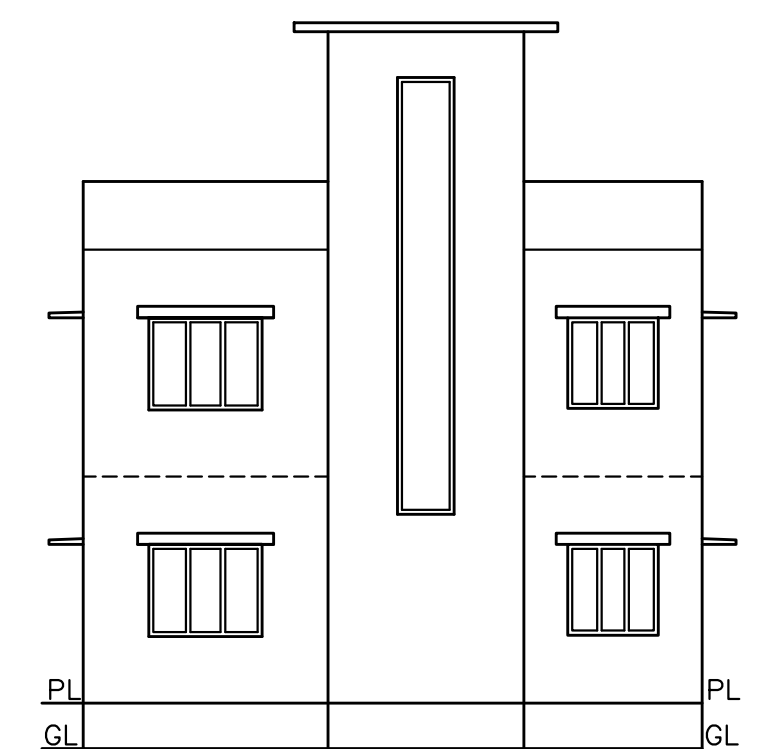

SOUTH SIDE ELEVATION
SCALE 1:100

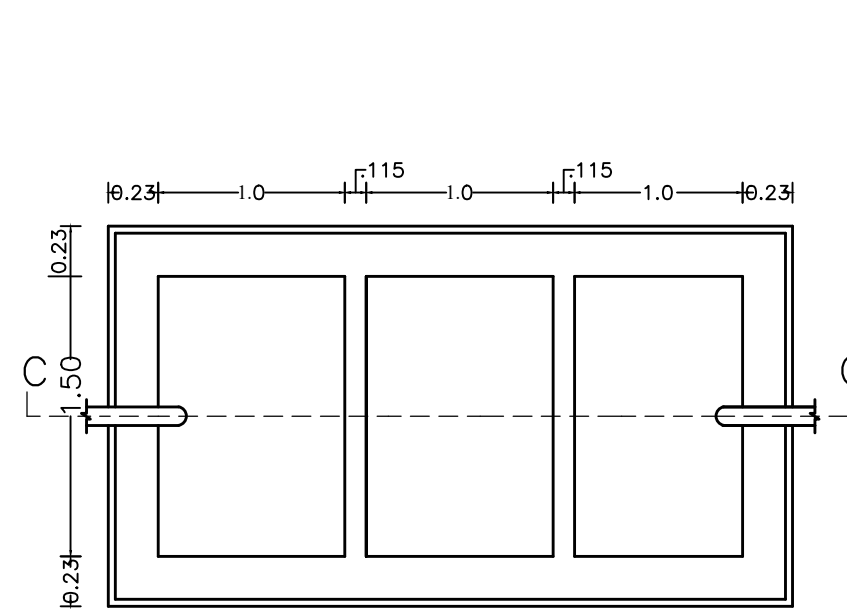

SEPTIC TANK PLAN
SCALE -1:50

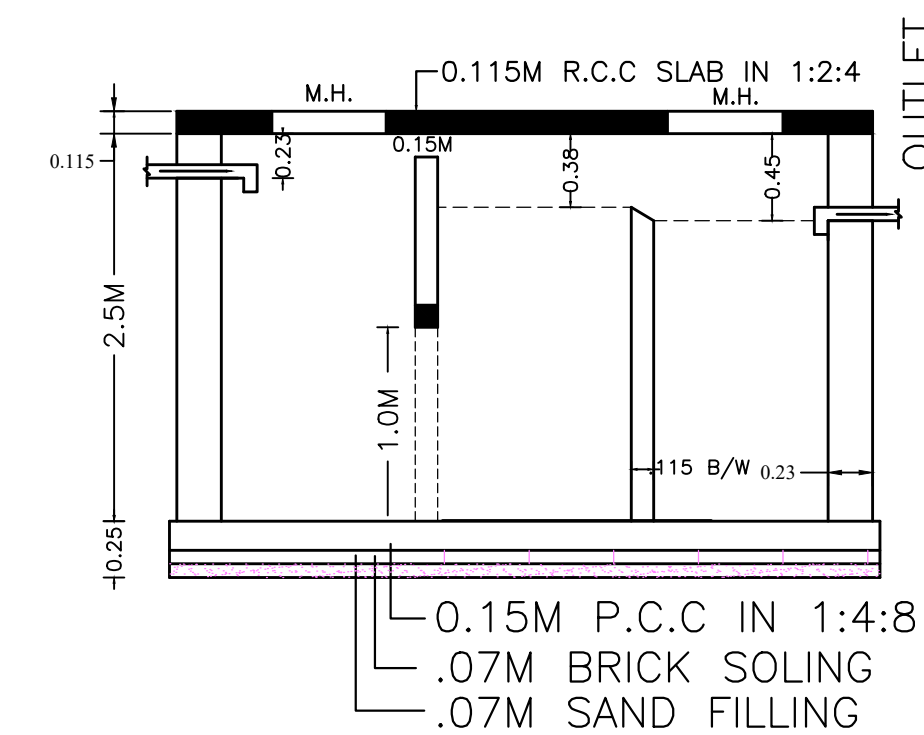

SECTION - SS
SCALE -1:50

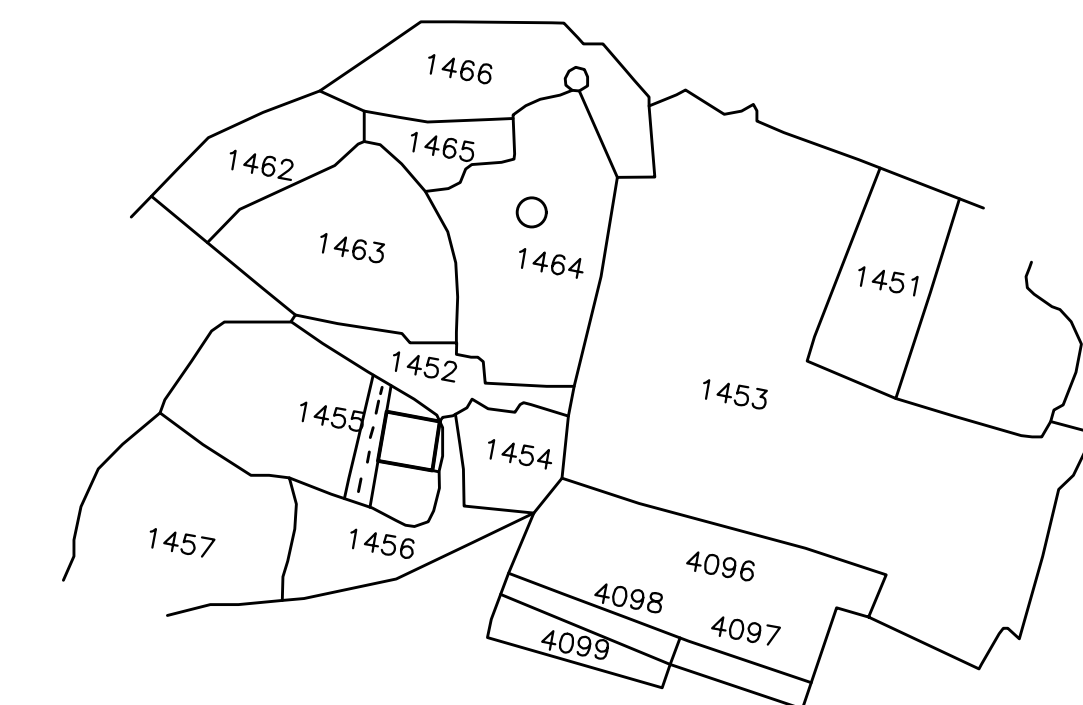

MOUZA PLAN (NTS)

UnitBUA Table for Building :A (RESIDENTIAL)

FLOOR	Name	UnitBUA Type	UnitBUA Area	Carpet Area	No. of Rooms	No. of Tenement
GROUND FLOOR PLAN	SPLIT A	FLAT	117.21	112.54	6	1
FIRST FLOOR PLAN	SPLIT A	FLAT	0.00	0.00	8	0
Total:	-	-	117.21	112.54	14	1

LTP NAME AND SIGNATURE	STRUCTURAL ENG'S NAME AND SIGNATURE	BUILDER NAME AND SIGNATURE	DIGITAL SIGNATURE
EJAZ AHMAD MNAC/DFTMN/0008/2020			

Proposal Basic Information

Proposal File No.	MNAC/BP/0011/W/10/2023
Owner Name	MRS. NIRMALA DEVI
Khata No	425
Plot No	1455
Village Name	Baliguma
Use	Residential
SubUse	Bungalow/ Dwelling / Non Apartment

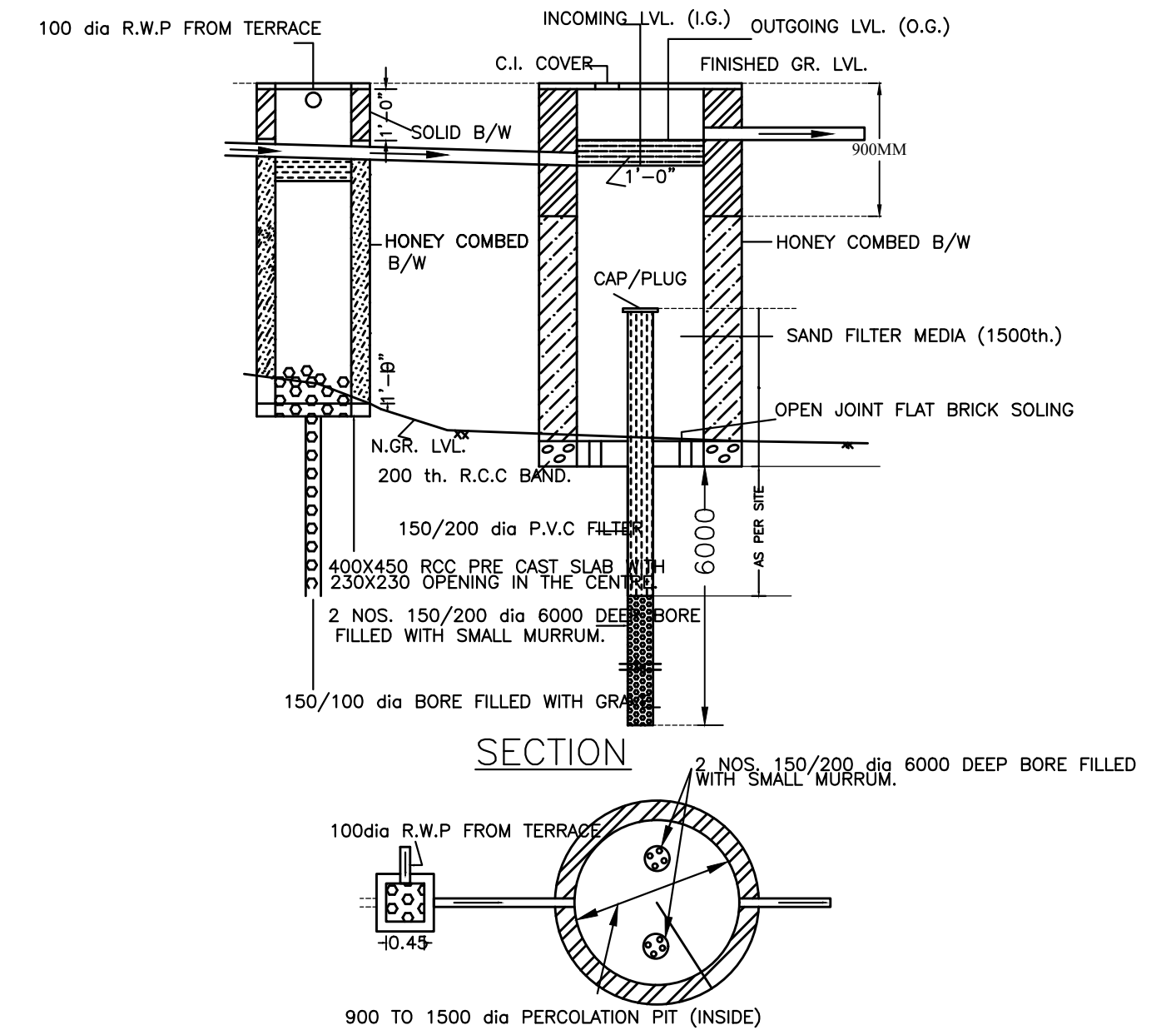

WATER HARVESTING PLAN (NTS)

LTP NAME AND SIGNATURE	STRUCTURAL ENG'S NAME AND SIGNATURE	BUILDER NAME AND SIGNATURE	DIGITAL SIGNATURE
EJAZ AHMAD MNAC/DFTMN/0008/2020			