

Project Title :MARIYAM BEGUM AND ABDA BEGUM

AREA STATEMENT	MANGO MUNICIPAL CORPORATION	VERSION NO. :- 1.0.30
PROJECT DETAIL		VERSION DATE: 08/03/2023
Plot No.	266	Plot Use: Residential
Region	RAJSHAHAR (URBAN LOCAL BODIES)	Plot Sub-Use: Single/Dwelling / Non Apartment
Owner	EAST SINGHBHUM	Land Use Zone: NA
Application Type	General Proposal	Building Floor: .....
Project Type	Building Permission	Plot No.:
Nature of Development	New	Revenue Survey No/Survey No.:
Location	Old Area	Check No.:
Sub-Location	NA	Holding No.:
Wing/Block Name	-	Khata No.:
West Side	-	North
Road/Street	-	South
		East
		West

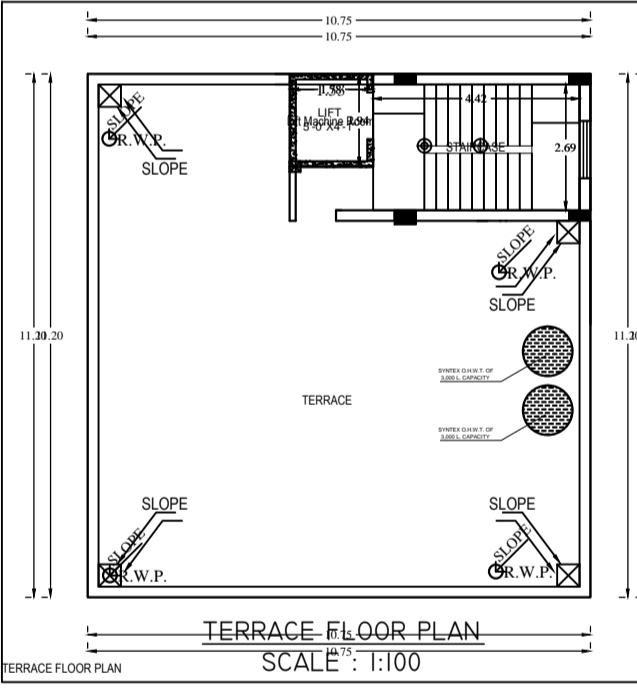
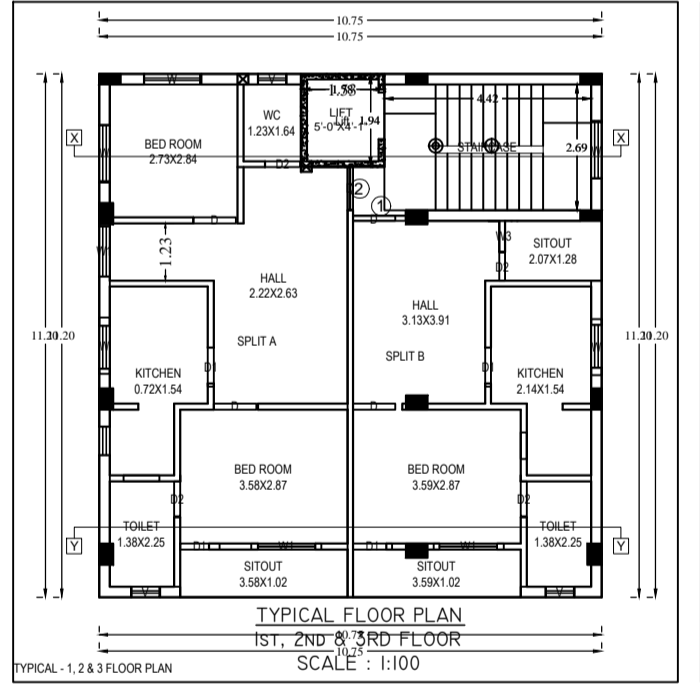
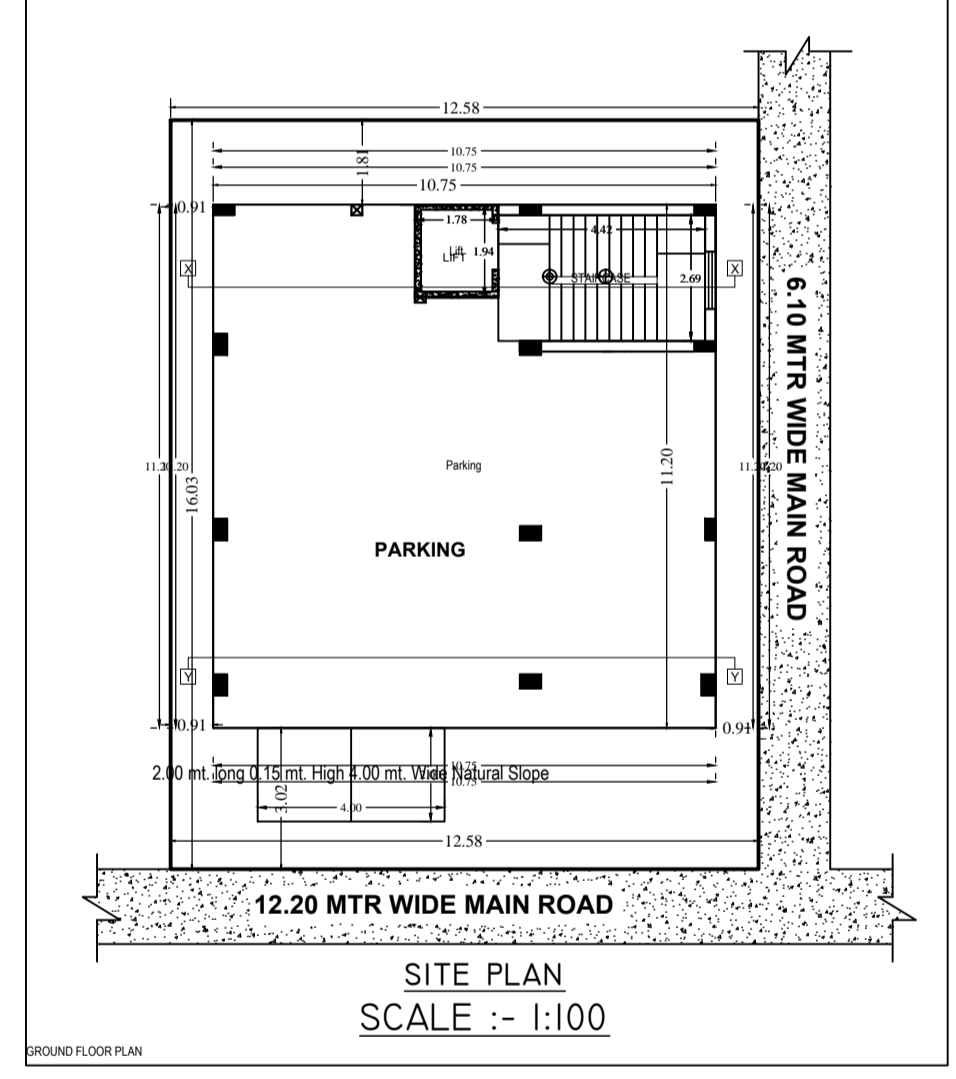
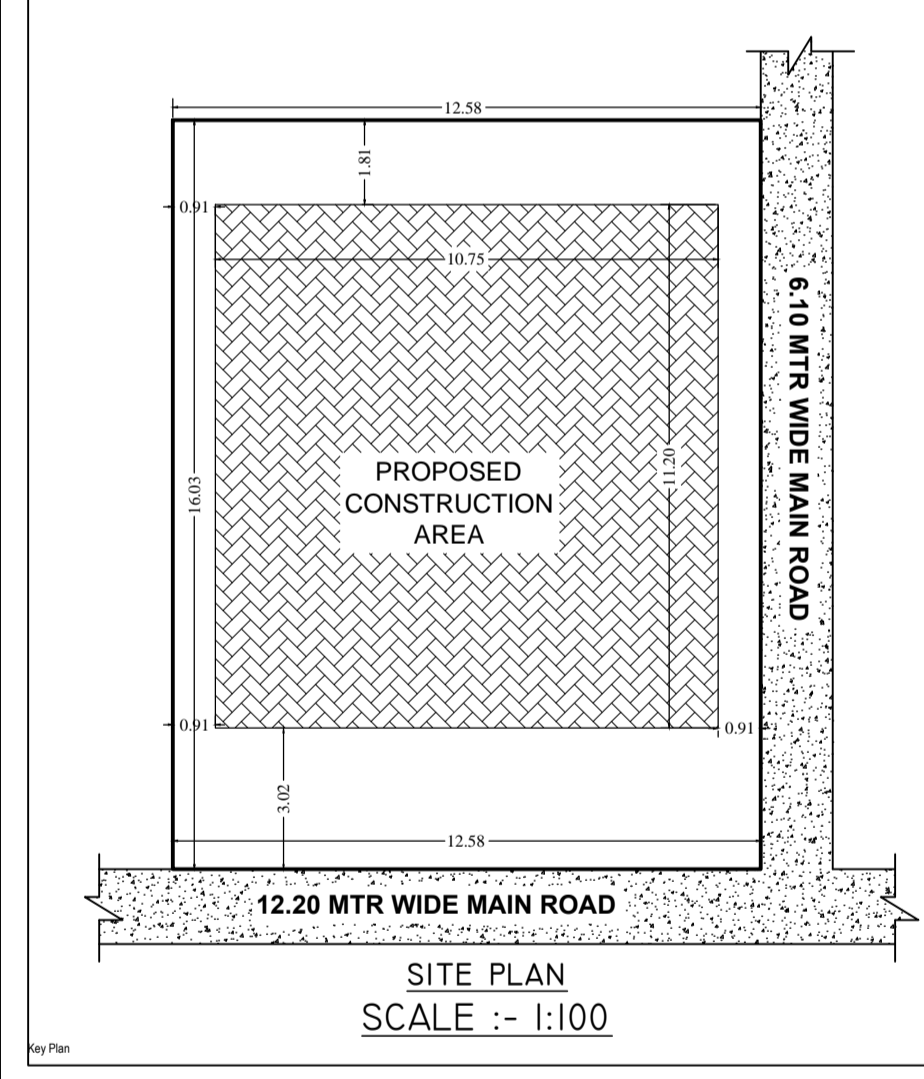
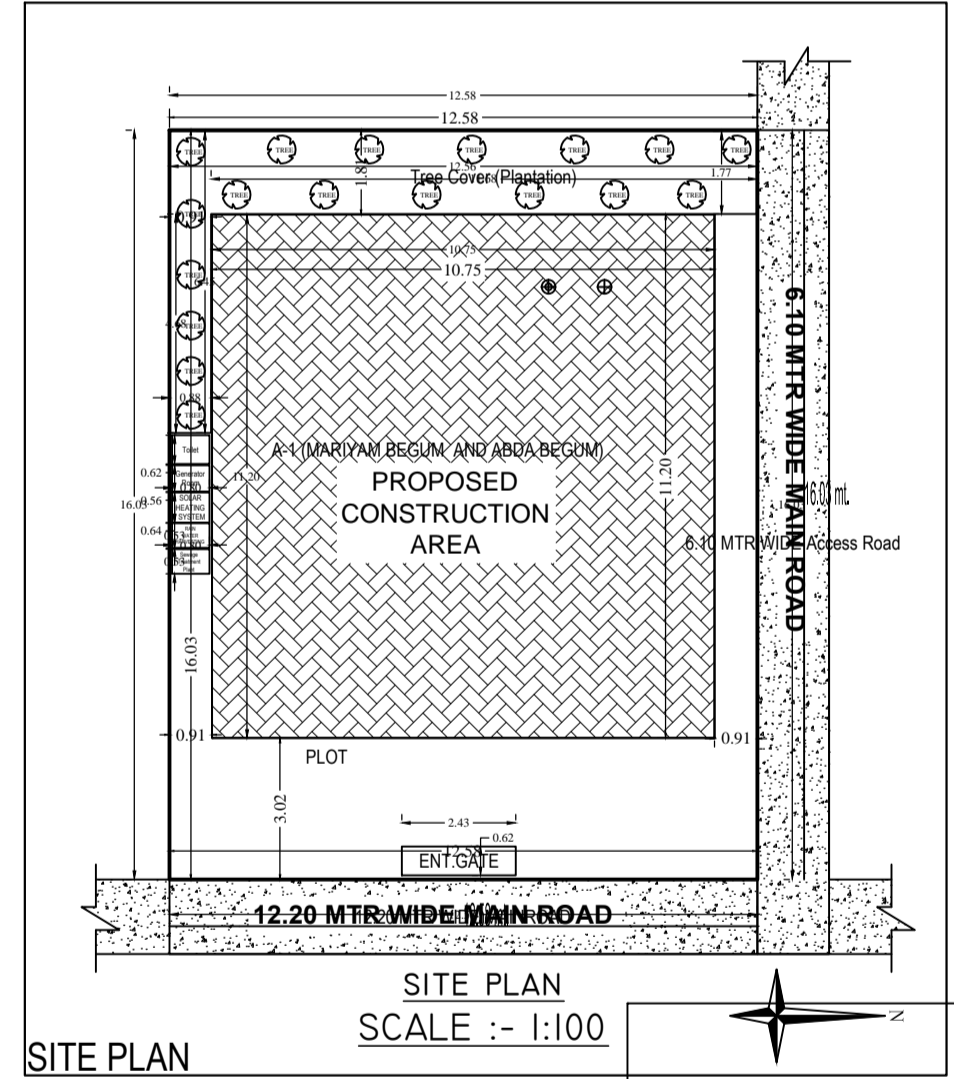
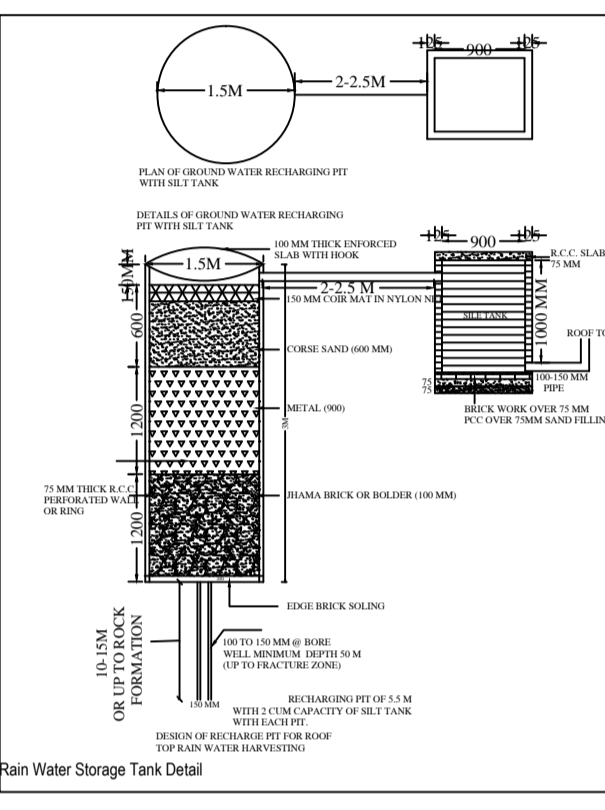
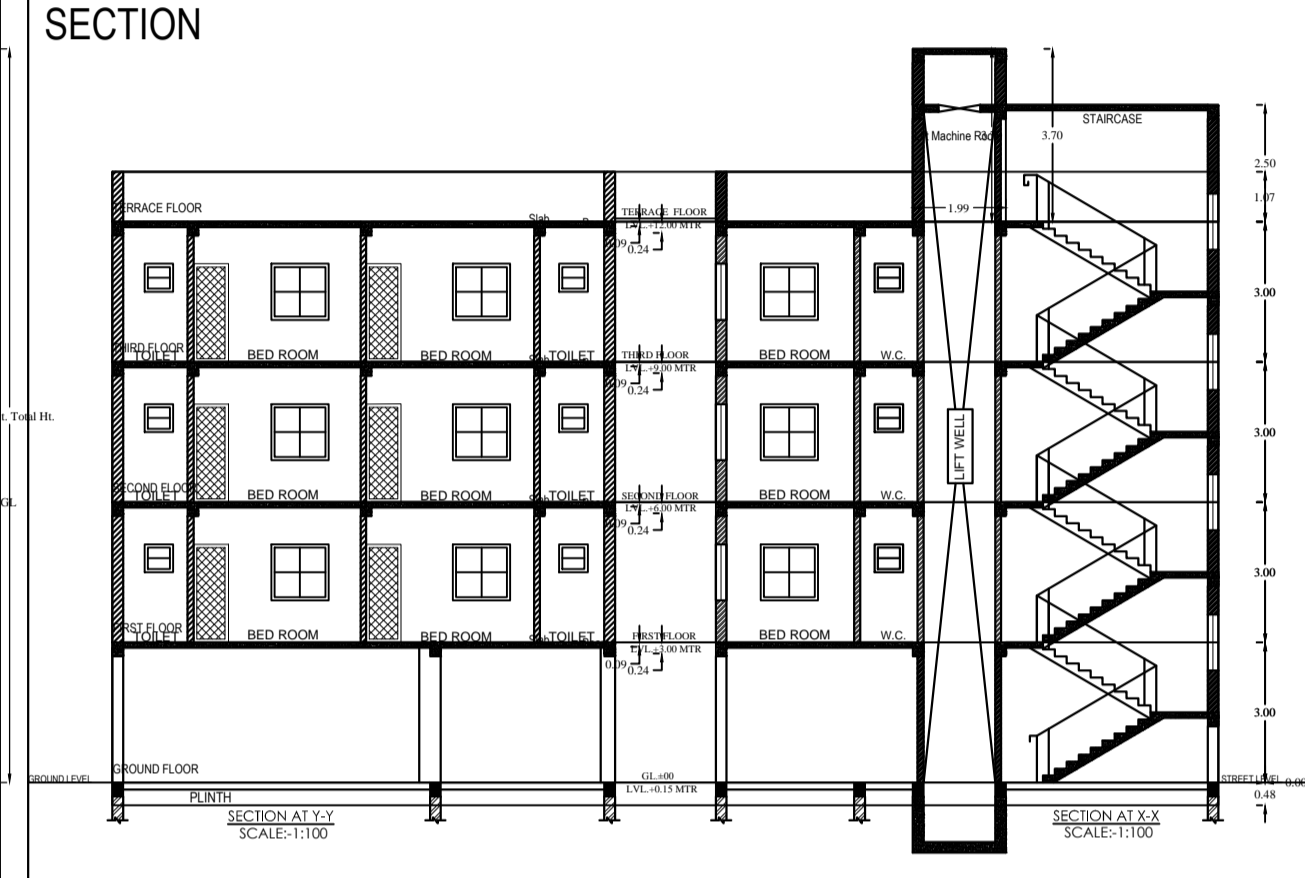
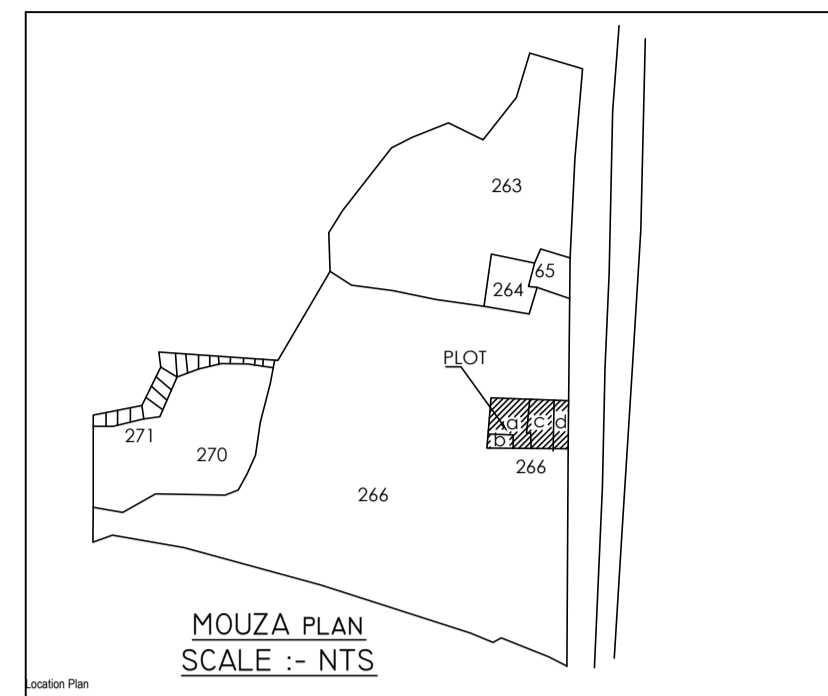
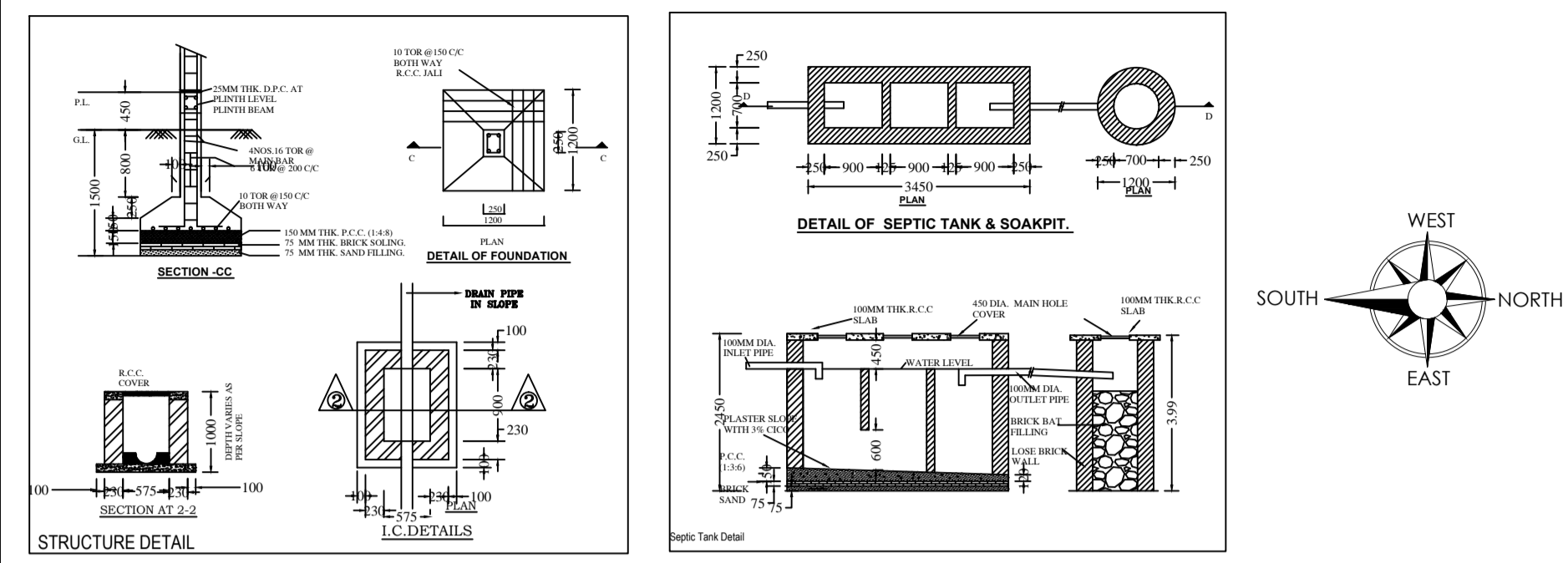

**LAND DETAILS**  
PROPOSED RESIDENTIAL BUILDING PLAN OF  
**(1) MARIYAM BEGUM**  
D/O LATE. SYED IDULLAH  
**(2) ABDA BEGUM**  
D/O LATE. SYED IDULLAH  
PLOT NO- 266 , KHATA NO.- 1062  
MOUZA - MANGO, WARD NO-8  
WARD NO- 8 , THANA NO - 16421  
HOLDING NO- 0010014748000X1  
DISTRICT. - EAST SINGHBHUM  
STATE -- JHARKHAND.

LAND OWNER: \_\_\_\_\_  
APPLICANT'S SIGNATURE: \_\_\_\_\_  
SIGNATURE OF ARCHITECT: \_\_\_\_\_

Building A (MARIYAM BEGUM AND ABDA BEGUM)

Floor Name	Total Built Up Area (Sq.mt.)	Deductions (Area in Sq.mt.)	Proposed FAR Area (Sq.mt.)	Add Area in FAR (Sq.mt.)	Total FAR Area (Sq.mt.)	Trent (No.)
Ground Floor	117.01	0.00	105.14	0.00	11.87	11.87
First Floor	120.45	3.44	0.00	117.01	0.00	117.01
Terrace Floor	120.45	3.44	0.00	117.01	0.00	117.01
Total	478.30	10.32	105.14	351.03	11.87	362.90

SCHEDULE OF JOINERY:

BUILDING NAME	NAME	LENGTH	HEIGHT	NOS
A (MARIYAM BEGUM AND ABDA BEGUM)	D2	0.60	2.13	03
	D2	0.75	2.13	09
	D1	0.84	2.13	12
	D	0.91	2.13	15
Total	-	-	-	39

SCHEDULE OF JOINERY:

BUILDING NAME	NAME	LENGTH	HEIGHT	NOS
A (MARIYAM BEGUM AND ABDA BEGUM)	V	0.60	1.00	09
	W3	0.86	2.70	03
	W1	1.07	2.70	03
	W	1.20	2.70	15
	W1	1.50	2.70	06
Total	-	-	-	36

Unit/BUA Table for Building A (MARIYAM BEGUM AND ABDA BEGUM)

FLOOR	Name	Unit/BUA Type	Unit/BUA Area	Cost/BUA	No. of Rooms	No. of Tenement
TYPICAL - 1	SPLIT A	FLAT	53.67	53.57	7	6
2 & 3 FLOOR PLAN	SPLIT B	FLAT	40.90	40.91	5	6
Total	-	-	201.94	202.42	20	6

COLOR INDEX

ABUTTING ROAD	█
PROPOSED WORK COVERAGE AREA	█
EXISTING (To be retained)	█
EXISTING (To be demolished)	█

PARKING CALCULATION:

Parking Type	Prop. No.	Prop. Area
Other Parking	1	105.14
Total Area	1	105.14

MARGIN DETAIL:

Building Name	Road Name	Front Margin	Rear Margin	Side1 Margin	Side2 Margin
A (MARIYAM BEGUM AND ABDA BEGUM)	12.20 MTR WIDE MAINROAD	3.02	1.81	0.91	0.91

FAR & Tenement Details (Table 4c-1)

Building	No. of Same Bldg	Total Built Up Area (Sq.mt.)	Deductions (Area in Sq.mt.)	Proposed FAR Area (Sq.mt.)	Add Area in FAR (Sq.mt.)	Total FAR Area (Sq.mt.)	Trent (No.)
A (MARIYAM BEGUM AND ABDA BEGUM)	1	478.30	10.32	105.14	351.03	11.87	362.90
Grand Total	1	478.30	10.32	105.14	351.03	11.87	362.90